



**Electronic Level Inclinometer  
with Rotating Display  
Model No. 40-6080**



# Instruction Manual

*Congratulations on your choice of this Electronic Level Inclinometer with Rotating Display. We suggest you read this instruction manual thoroughly before using the instrument. Save this instruction manual for future use.*

This is a Class IIIa laser tool and is manufactured to comply with CFR 21, parts 1040.10 and 1040.11 as well as international safety rule IEC 285.

# Table of Contents

1. Kit Contents
2. Features and Functions
3. Safety Instructions
4. Location/Content of Warning Labels
5. Location of Parts/Components
6. Operating Instructions
7. Using the Product
8. Self-Check and Calibration
9. Technical Specifications
10. Care and Handling
11. Product Warranty

## 1. Kit Contents

<u>Description</u>	<u>Qty.</u>
“AAA” Alkaline Batteries	3
Carrying Case	1

## 2. Features and Functions

- Switchable between angle and grade
- Small and handy
- LCD can rotate 180°
- Inclination in degrees or percent
- Self-calibrated
- 0° and 90°-position of inclination is confirmed by a signal tone
- Magnetic Base
- 1/4” - 20 thread for connection to tripod

### 3. Safety Instructions

Please read and understand all of the following instructions, prior to using this tool. Failure to do so, may result in bodily injury.

#### ATTENTION



#### IMPORTANT

- Read all instructions prior to operating this laser tool. Do not remove any labels from tool.
- Do not stare directly at the laser beam.
- Do not project the laser beam directly into the eyes of others.
- Do not set up laser tool at eye level or operate the tool near a reflective surface as the laser beam could be projected into your eyes or into the eyes of others.
- Do not place the laser tool in a manner that may cause someone to unintentionally look into the laser beam. Serious eye injury may result.
- Do not operate the tool in explosive environments, i.e. in the presence of gases or flammable liquids.
- Keep the laser tool out of the reach of children and other untrained persons.
- Do not attempt to view the laser beam through optical tools such as telescopes as serious eye injury may result.
- Always turn the laser tool off when not in use or left unattended for a period of time.
- Remove the batteries when storing the tool for an extended time (more than 3 months) to avoid damage to the tool should the batteries deteriorate.
- Do not attempt to repair or disassemble the laser tool. If unqualified persons attempt to repair this tool, warranty will be void.

#### CAUTION!

Class IIIa Laser Product

Max. Power Output:  $\leq 5\text{mW}$

Wavelength: 640-660nm

**THIS TOOL EMITS LASER RADIATION.  
DO NOT STARE INTO BEAM.  
AVOID DIRECT EYE EXPOSURE.**



## 4. Location/Content of Warning Labels



## 5. Location of Part/Components

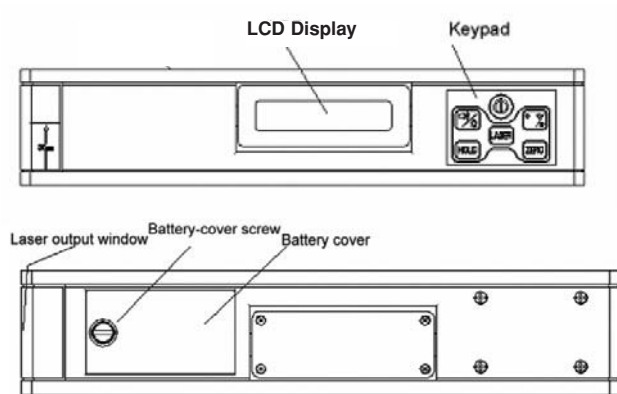

## 6. Operating Instructions

**IMPORTANT:** It is the responsibility of the user to verify the calibration of the instrument before each use.

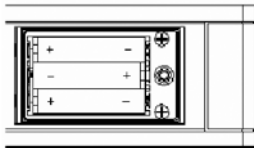
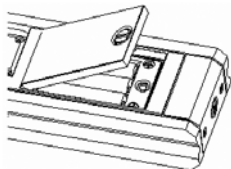

### Battery Installation

1. Open the battery cover by turning the screw counter-clockwise, and then put the 3 “AAA” batteries into the battery case according to the polarity shown in the battery slot.
2. Snap the battery cover back, and then tighten the screw clockwise.

### Note:

1. Take out the batteries if the instrument is not going to be used for a long time.
2. Replace the batteries when the voltage gets low.
3. Turn the instrument off while taking out the old batteries from the battery case.

## 7. Using the Product

### Key Guide

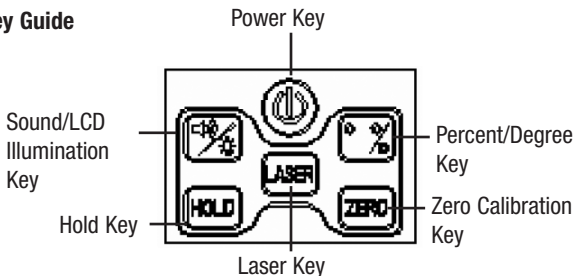

### Power Key

Turn on/off the instrument. The instrument will beep twice when turned on and beep once when turned off.



### Hold Key

Pressing this key will lock the current angle reading displayed on the LCD.



### Sound/LCD Illumination Key

Press this key once to turn on/off the LCD back light. The instrument will beep once. Press and hold this key for 3 seconds to turn on/off the sound function. When sound function is on you will see the horn symbol on the LCD. There will be no beeps if the instrument is at 10° or more. A faster beep will start as you move closer to level. A steady tone will beep when level is at 0.0° or 90%.



## °% Key

Push once to switch between the percent and the angle readings. The unit will beep once.



## Laser Key

Turn on/off the laser. The instrument will beep once.



## Zero Calibration Key

Please refer to Section 8 “Self-check and calibration”.

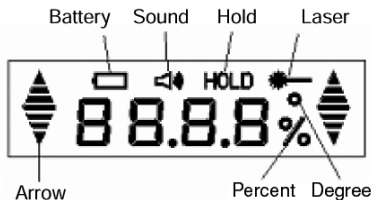

## Low Voltage Indication

 If the battery symbol on the display is low, change the batteries as soon as possible. Non-display of battery symbol means the battery is full.

## Sound Function

 The SOUND symbol displayed on the LCD means that the sound function is activated. The level will beep faster when the instrument gets closer to the position of 0 degree and 90 degrees. When the LCD displays 0 degree or 90 degrees, there will come a continuous tone sound.

## Hold Function

Press the hold key once (unit will beep once) to activate this function and to display the HOLD symbol on the LCD. Now the instrument will hold the current angle reading and the display will flash.

## Laser Indication Function



The Laser symbol displayed on the LCD means that the laser beam is activated. The laser output window will emit a bright red laser dot.

## Angle Display Function



The inclination angle will be displayed in the form of a degree.



The inclination angle will be displayed in the form percent of degree.

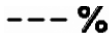

In the percent grade display, if the inclination angle is beyond 45 degrees or 100%, this symbol will be displayed on the LCD.

## Inclination Indication

The triangle arrows displayed on the two ends of the LCD indicate the inclination direction of the laser digital level.

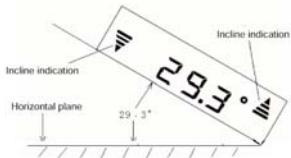
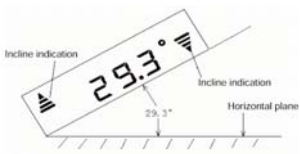

When the laser digital level is at the position of 0 degree, the two arrows will show as follows:



### Rotating Display

The LCD of the instrument can rotate 180 degrees.

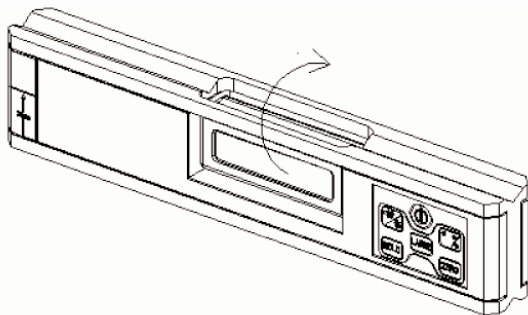

## 8. Self-Check and Calibration

**IMPORTANT:** It is the responsibility of the user to verify the calibration of the instrument before each use.

### Checking the Horizontal Calibration

Select a flat and horizontal platform as a reference surface, like a table-surface.

1. Place the laser digital level on this reference surface, as shown in figure 1, and then record the measured angle reading. Record this as A1.
2. Turn the laser digital level 180 degrees, as shown in figure 2, and then record the measured angle reading. Record this as A2.
3. If A1-A2 is greater than  $.02^{\circ}$ , it is necessary to calibrate the horizontal accuracy.



Fig 1



Fig 2



### Checking the Vertical Calibration

Select a flat and vertical platform as a reference surface.

1. Place the laser digital level on this reference surface, as shown in figure 3, and then record the measured angle reading. Record this as A1.
2. Turn the laser digital level 180 degrees, as shown in figure 4, and then record the measured angle reading. Record this as A2.
3. If A1-A2 is greater than  $.02^{\circ}$ , it is necessary to calibrate the vertical accuracy.

The same vertical reference surface

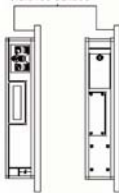
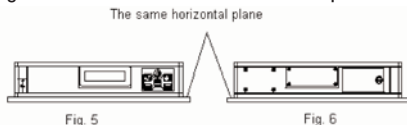

Fig 3

Fig 4

## Horizontal Calibration

1. Press and hold the ZERO key for 3-plus seconds, unit will beep once. When the LCD shows -0-, it means the instrument has already entered the calibration status.
2. Place the laser digital level on the horizontal reference surface, as shown in figure 5, after 10 seconds, press the ZERO again, and the LCD shows -1-.
3. Turn the laser digital level 180 degrees, as shown in figure 6, and after 10 seconds, press the ZERO key again, and the LCD shows -2-. Wait for 2 seconds, and the laser digital level will show the angle reading. The horizontal calibration is now completed.



## Vertical Calibration

1. Press and hold the ZERO key for 3-plus seconds, unit will beep once. When the LCD shows -0-, it means the instrument has already entered the calibration status.
2. Place the laser digital level on the vertical reference surface, as shown in figure 7, after 10 seconds, press the ZERO again, and the LCD shows -1-.
3. Turn the laser digital level 180 degrees, as shown in figure 6, and after 10 seconds, press the ZERO key again, and the LCD shows -2-. Wait for 2 seconds, and the laser digital level will show the angle reading. The vertical calibration is now completed.

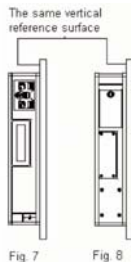

## 9. Technical Specifications

Laser Wavelength	650nm $\pm$ 10
Laser Classification	Class IIIa
Maximum Power Output	$\leq$ 5mW
Accuracy	$\pm$ 0.1° for 0° and 90°, and $\pm$ 0.2° for 1° to 89°
Laser Accuracy	$\pm$ 1/8"/50 ft. ( $\pm$ 0.2mm/m)
Resolution	$\pm$ 0.1° or 0.1%
Interior Range	Continuous from 0° to 360°, displayed as 0.0° to 90°
Power Supply	3 "AAA" alkaline batteries
Battery Life	Approx. battery life 70 hours continuous use
Dimensions	9.8" x 1.18" x 2.17" (250 x 30 x 55mm)
Weight	1.23 lbs. (0.56 Kg)
Working Temperature	14°F to 113°F (-10°C to +45°C)

## 10. Care and Handling

- This laser unit is a precision tool that must be handled with care.
- Avoid exposing unit to shock vibrations and extreme temperatures.
- Before moving or transporting the unit, make sure that the unit is turned off.
- Remove the batteries when storing the unit for an extended time (more than three months) to avoid damage to the unit should the batteries deteriorate.
- Always store the unit in its case when not in use.
- Avoid getting the unit wet.
- Keep the laser unit dry and clean, especially the laser output window. Remove any moisture or dirt with a soft, dry cloth.
- Do not use harsh chemicals, strong detergents or cleaning solvents to clean the laser unit.

## 11. Product Warranty

Johnson Level & Tool offers a one year limited warranty on each its products. You can obtain a copy of the limited warranty for a Johnson Level & Tool product by contacting Johnson Level & Tool's Customer Service Department as provided below or by visiting us online at [www.johnsonlevel.com](http://www.johnsonlevel.com). The limited warranty for each product contains various limitations and exclusions.

**NOTE:** The user is responsible for the proper use and care of the product.

It is the responsibility of the user to verify the calibration of the instrument before each use.

For further assistance, or if you experience problems with this product that are not addressed in this instruction manual, please contact our Customer Service Department.

In the U.S., contact Johnson Level & Tool's Customer Service Department at 800-563-8553.

In Canada, contact Johnson Level & Tool's Customer Service Department at 800-346-6682.

