



Digital Laser Level & Angle Locator
Model No. 40-6065



Instruction Manual

Congratulations on your choice of this Digital Laser Level & Angle Locator. We suggest you read this instruction manual thoroughly before using the instrument. Save this instruction manual for future use.

This is a Class IIIa laser tool and is manufactured to comply with CFR 21, parts 1040.10 and 1040.11 as well as international safety rule IEC 285.

Table of Contents

1. Kit Contents
2. Features and Functions
3. Safety Instructions
4. Location/Content of Warning Labels
5. Location of Parts/Components
6. Operating Instructions
7. Using the Product
8. Self-Check and Calibration
9. Technical Specifications
10. Care and Handling
11. Product Warranty

1. Kit Contents

<u>Description</u>	<u>Qty.</u>
“AA” Alkaline Batteries	3
Carrying Case	1

2. Features and Functions

- Displays angle and inclination simultaneously
- Angle measurements in degrees
- Angle inclination in degrees or percent
- Automatic digit inversion for overhead measurements
- Working range of angle measurement 0 to 180°
- Automatic shut-off
- Hold-function to freeze measurement
- 180°-lock to prolong the unit to 1m length
- Arm can be locked in every desired position
- Visible laser beam to extend working range
- 1/4” - 20 thread for connection to tripod

3. Safety Instructions

Please read and understand all of the following instructions, prior to using this tool. Failure to do so, may result in bodily injury.

ATTENTION



IMPORTANT

- Read all instructions prior to operating this laser tool. Do not remove any labels from tool.
- Do not stare directly at the laser beam.
- Do not project the laser beam directly into the eyes of others.
- Do not set up laser tool at eye level or operate the tool near a reflective surface as the laser beam could be projected into your eyes or into the eyes of others.
- Do not place the laser tool in a manner that may cause someone to unintentionally look into the laser beam. Serious eye injury may result.
- Do not operate the tool in explosive environments, i.e. in the presence of gases or flammable liquids.
- Keep the laser tool out of the reach of children and other untrained persons.
- Do not attempt to view the laser beam through optical tools such as telescopes as serious eye injury may result.
- Always turn the laser tool off when not in use or left unattended for a period of time.
- Remove the batteries when storing the tool for an extended time (more than 3 months) to avoid damage to the tool should the batteries deteriorate.
- Do not attempt to repair or disassemble the laser tool. If unqualified persons attempt to repair this tool, warranty will be void.

CAUTION!

Class IIIa Laser Product

Max. Power Output: $\leq 5\text{mW}$

Wavelength: 640-660nm

**THIS TOOL EMITS LASER RADIATION.
DO NOT STARE INTO BEAM.
AVOID DIRECT EYE EXPOSURE.**



4. Location/Content of Warning Labels

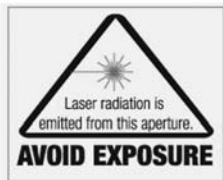

5. Location of Part/Components

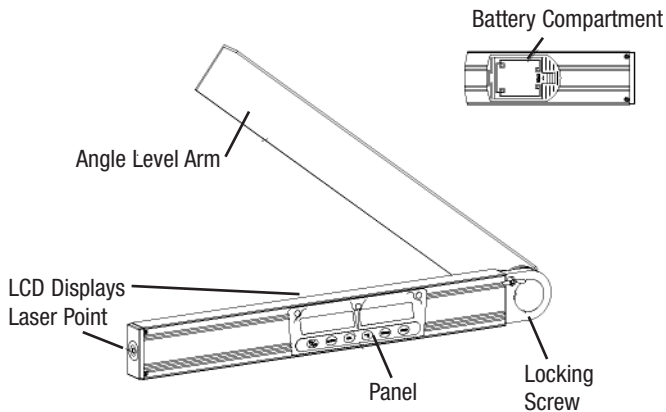

6. Operating Instructions

IMPORTANT: It is the responsibility of the user to verify the calibration of the instrument before each use.

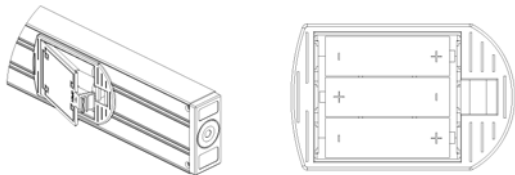

Battery Installation

1. Make sure the instrument is turned off.
2. Open the battery cover. Take out the old batteries and put the new batteries in paying attention to the polarity.
3. Power on the instrument.

Note:

1. Used (discharged) batteries are hazardous waste and should be disposed of properly.
2. Take out the batteries if the instrument is not going to be used for a long time.

7. Using the Product

Key Guide

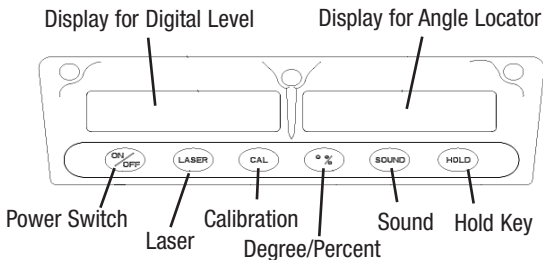

The instrument has six operating keys with their functions below:

On/Off Key

Power on and off the instrument by pressing this key. The instrument will beep twice when turning it on and off.



Laser Key

Pressing this key will turn on the laser beam and the laser icon will appear on the LCD. The instrument will also beep once. Pressing this key again will turn off the laser beam and the laser icon will disappear on the LCD. **Note:** The instrument must be turned on for the laser beam to work.



CAL Key

The calibration key is used for re-calibrating the instrument in both the horizontal and vertical direction. Refer to Section 8 “Calibration” for details.



°% Key

This key switches the instrument between the degree and percent readings. The instrument will beep once.



Sound Key

Pressing this key will turn on the sound function and the sound icon will appear on the LCD. Pressing the key again will turn off the sound function and the sound icon will disappear on the LCD. The instrument will beep once when turning the sound on and off. The beep will sound at 0° and 90°.



Hold Key

The angle readings change in accordance with the change of the incline and angle measurement. Press the key (unit will beep once) to enter into the “hold” mode. The measured angle reading will be held. The display will flash and the flash figures will not change. Pressing the key again (unit will beep once) will stop the “hold” mode and measured value will change with the incline.

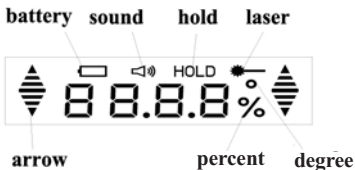

Automatic Shut-off

This instrument will shut-off automatically if no operation is received within six minutes.

Low-power Indication

The battery symbol will flash on the LCD when the battery power is low. Please replace the batteries as soon as possible.

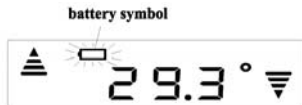

Incline Indication Arrows

The following figure shows that moving the angle level according to the indicated direction arrows is necessary if you want to position the level to horizontal or vertical.



The following figure shows that the level is level or plumb.

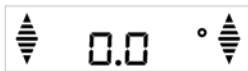

Locking Arm

When the surface is too long, turn the angle level arm to 180° , then tighten the locking screw clockwise, which can extend the level longer. You can also lock the arm at any angle within the range of 0° to 180° .

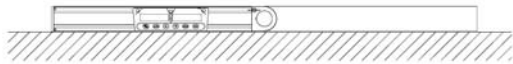
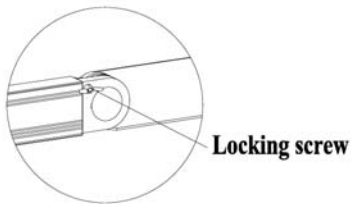

The laser point will be parallel with the reference plane

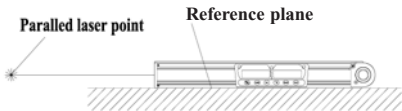

Measuring the inclining angle to the level plane.

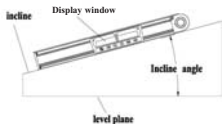

Measuring an angle.

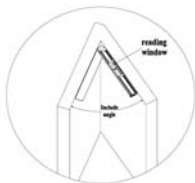

8. Self-Check and Calibration

IMPORTANT: It is the responsibility of the user to verify the calibration of the instrument before each use.

To guarantee the best measuring precision of the incline, vertical and leveling plane:

- Calibrate before first use.
- Before important measurements.
- After a hit or drop.

Horizontal Calibration

Put the angle level on a smooth level plane and observe the LCD display. Note the reading after ten seconds. Then turn the angle level 180° on the same plane. After another ten seconds note the second angle reading. Calibration is necessary if the difference between the two measuring readings is over 0.1° .

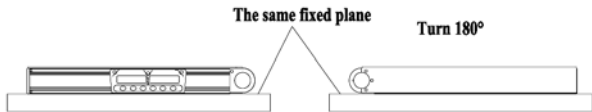

Vertical Calibration

Put the angle level on a smooth vertical plane and observe the LCD display. Note the reading after 10 seconds. Then turn the angle level 180° on the same plane. After another ten seconds note the second angle reading. The calibration is necessary if the difference between the two measuring readings is over 0.1%.

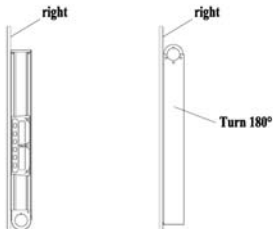

9. Technical Specifications

Laser Wavelength	650nm \pm 10
Laser Classification	Class IIIa
Maximum Power Output	\leq 5mW
Laser Accuracy	\pm 1/8"/50 ft. (\pm 0.2mm/m)
Working Range Angle	0°-180°
Accuracy Angle	\pm 0.1°
Working Range Inclination	0°-90° or 0% - 100%
Resolution	0.1° or 0.1%
Accuracy Inclination	0.2°
Power Supply	3 "AA" alkaline batteries
Battery Life	Approx. battery life 70 hours continuous use
Dimensions	20.8" x 2.48" x 1.57" (530 x 63 x 40mm)
Weight	2.6 lbs. (1.2 Kg)
Working Temperature	14°F to 113°F (-10°C to +45°C)

10. Care and Handling

- This laser unit is a precision tool that must be handled with care.
- Avoid exposing unit to shock vibrations and extreme temperatures.
- Before moving or transporting the unit, make sure that the unit is turned off.
- Remove the batteries when storing the unit for an extended time (more than three months) to avoid damage to the unit should the batteries deteriorate.
- Always store the unit in its case when not in use.
- Avoid getting the unit wet.
- Keep the laser unit dry and clean, especially the laser output window. Remove any moisture or dirt with a soft, dry cloth.
- Do not use harsh chemicals, strong detergents or cleaning solvents to clean the laser unit.

11. Product Warranty

Johnson Level & Tool offers a one year limited warranty on each its products. You can obtain a copy of the limited warranty for a Johnson Level & Tool product by contacting Johnson Level & Tool's Customer Service Department as provided below or by visiting us online at www.johnsonlevel.com. The limited warranty for each product contains various limitations and exclusions.

NOTE: The user is responsible for the proper use and care of the product.

It is the responsibility of the user to verify the calibration of the instrument before each use.

For further assistance, or if you experience problems with this product that are not addressed in this instruction manual, please contact our Customer Service Department.

In the U.S., contact Johnson Level & Tool's Customer Service Department at 800-563-8553.

In Canada, contact Johnson Level & Tool's Customer Service Department at 800-346-6682.

