

GENERAC®

Protector™ Series

Owner's Manual For Stationary Diesel Generators

Residential and Commercial

Model

RD015 -	15 kW	60 Hz
RD020 -	20 kW	60 Hz
RD030 -	30 kW	60 Hz
RD048 -	48 kW	60 Hz (Single Phase Only)
RD050 -	50 kW	60 Hz (Three Phase Only)
0066781 -	30 kW	60 Hz

⚠ DANGER!



NOT INTENDED FOR USE IN CRITICAL LIFE SUPPORT APPLICATIONS.



ONLY QUALIFIED ELECTRICIANS OR CONTRACTORS SHOULD ATTEMPT INSTALLATION!



DEADLY EXHAUST FUMES! OUTDOOR INSTALLATION ONLY!

This manual should remain with the unit.

This manual must be used in conjunction with the appropriate installation manual.

Use this page to record important information about the generator set.

For quick and easy reference, copy the information printed on the Unit Identification Label onto the sample label printed here. The Unit Identification Label is located at the rear of the alternator on 15/20 kW (2.3L) units, and on the front engine mount on 30 kW (2.4L) and 50 kW (3.4L) models. The label provides the following information:

- Model Number
- Serial Number
- Rated KW
- Voltage Rating
- Maximum Current Rating (AMPS)

When contacting an Authorized Service Dealer about parts and/or service, always provide the complete model number and serial number.

Operation and Maintenance: Proper maintenance and care of the generator ensures safe operation and longer service life while also keeping operating expenses to a minimum. It is the operator's responsibility to perform all safety checks, to make sure that all maintenance is performed promptly, and to have the equipment checked periodically by an Authorized Service Dealer.

Normal maintenance, service and replacement of parts are the responsibility of the owner/operator, and are not considered defects in materials or workmanship within the terms of the warranty. Individual operating habits and usage may contribute to the need for additional maintenance or service.

When the generator requires servicing or repairs, contact an Authorized Service Dealer for assistance. Authorized service technicians are factory-trained and are capable of handling all service needs.

AUTHORIZED SERVICE DEALER LOCATION

To locate the nearest AUTHORIZED SERVICE DEALER, please call this number:
1-800-333-1322

or visit the dealer locator at:

www.generac.com/Service/DealerLocator/



GENERATOR UNIT

GEN MODEL: _____
 MODEL: _____
 SERIAL: _____
 ALTERNATE _____
 PROD DATE: _____
 COUNTRY OF ORIGIN: _____

GENERATOR DATA

KW	KVA	HZ	PF
UPSIZE	ALT	KW	KVA
VOLT		/	AMP
ENG RPM			ALT RPM
BREAKER	KW		AMP
X"D			X"D
3 PHASE DELTA			
UNBALANCED LOAD CAPACITY-25%			
ROTOR	STATOR		CLASS
WINDINGS @		AMBIENT	TEMP
			MANUF. LOC.

GENERAC POWER SYSTEMS, INC
WAUKESHA, WI USA

OK0876

SAMPLE LABEL

Table of Contents

Section 1 Safety

1.1 Introduction	1
1.2 Safety Information	2
1.3 General Hazards	2
1.4 Exhaust Hazards	3
1.5 Electrical Hazards	3
1.6 Fire Hazards	3
1.7 Explosion Hazards	3

Section 2 Specifications

2.1 Emission Information	5
2.1.1 Emissions Data Plate	5
2.2 Specifications	6
2.2.1 Engine	6
2.3 Engine Oil Recommendations	7
2.4 Coolant Water Treatment	7
2.5 Fuel Requirements	7
2.5.1 Fuel Maintenance	8
2.5.2 Fuel Maintenance	8
2.6 Battery Requirements	8
2.6.1 Battery Charger	8
2.7 Corrosion Protection	8
2.8 Accessories	8

Section 3 Activation and Startup

3.1 Orientation	11
3.2 Remove Side Access Panels	11
3.3 Prime Fuel System	12
3.4 Install Battery	12
3.5 Open Viewing Window	13
3.6 Start and Run Engine	13
3.7 Activate Unit	14
3.8 Operational Checks	15
3.8.1 Self Test	15
3.8.2 Check Manual Transfer Switch Operation	15

3.8.3 Electrical Checks 16
 3.8.4 Test Generator Under Load 16
 3.8.5 Check Automatic Operation 17
3.9 Final Instructions 17

Section 4 Operation

4.1 Control Panel 19
4.2 Auto/Manual/Off 19
4.3 Menu Navigation 20
4.4 Alarm/Warning Conditions 22
4.5 Change Time and Date 22
4.6 Programmable Timers 22
 4.6.1 Dealer Programmable 22
 4.6.1.1 Exercise Time 22
 4.6.2 User Programmable 23
 4.6.2.1 Start-Up Delay Timer 23
 4.6.2.2 Warm-Up Delay Timer 23
4.7 USB Port for Firmware Updates 23
4.8 Battery Charger 23
4.9 Transfer Switch Automatic Operation 23
 4.9.1 Automatic Sequence of Operation 24
 4.9.1.1 Utility Failure 24
 4.9.1.2 Cranking..... 24
 4.9.1.3 Load Transfer..... 24
4.10 Transfer Switch Manual Operation 24
 4.10.1 Transfer to Generator Power 25
 4.10.2 Transfer Back to Utility Power 25

Section 5 Maintenance

5.1 Component Locations 27
5.2 Access Panels 29
 5.2.1 Removal 29
 5.2.2 Installation 29
5.3 Service Maintenance Intervals 30
5.4 Remove From Service 31
5.5 30 Hour Break-In 31

5.6 Daily Maintenance (If Running Continuously)	31
5.7 Schedule A Maintenance	32
5.7.1 Preliminary Instructions	32
5.7.2 Check Fuel Level and Fill	32
5.7.3 Drain Fuel Filter and Check Fuel Lines/Hoses	32
5.7.4 Check Coolant Level and Hoses	33
5.7.5 Check Radiator for Clogging	34
5.7.6 Check Lubricating Oil Level	34
5.7.7 Check Battery Condition/Fluid Level	35
5.7.7.1 Check Condition and Clean	35
5.7.7.2 Check Fluid Level	35
5.7.7.3 Check State of Charge.....	35
5.7.7.4 Battery Replacement	35
5.7.8 Check and Adjust V-Belt	37
5.7.8.1 Check.....	37
5.7.8.2 Adjust.....	38
5.7.9 Replace Air Filter Element	38
5.7.10 Drain Breather Canister and Replace Filter	38
5.7.11 Lubricate Governor Rod Linkage	39
5.7.12 Final Instructions	39
5.8 Schedule B Maintenance	40
5.8.1 Replace Lubricating Oil and Oil Filter	40
5.8.2 Replace Fuel Filter	41
5.8.2.1 Prime Fuel System.....	41
5.8.3 Drain/Flush Coolant System	41
5.8.4 Final Instructions	42
5.9 Schedule C Maintenance	43
5.10 Return To Service	43
 Section 6 Troubleshooting	
6.1 Engine Troubleshooting	45
6.2 Controller Troubleshooting	46
6.3 Removal From Service During Utility Outages	47
6.4 Storage	47
6.4.1 Prepare For Storage	47
6.4.2 Return From Storage	48
6.5 Attention After Submersion	49
6.6 Attention After Fuel Spillage	49
6.7 Contaminated Fuel Disposal	49

⚠ WARNING

California Proposition 65. Engine exhaust and some of its constituents are known to the state of California to cause cancer, birth defects, and other reproductive harm. (000004)

⚠ WARNING

California Proposition 65. This product contains or emits chemicals known to the state of California to cause cancer, birth defects, and other reproductive harm. (000005)

Section 1 Safety

1.1 — Introduction

Thank you for purchasing this stationary automatic standby generator set. Every effort was made to ensure that the information in this manual was both accurate and complete at the time it was released. However, the manufacturer reserves the right to change, alter or otherwise improve this product at any time without prior notice.

This generator is designed to automatically supply electrical power to operate critical loads during a utility power failure. The unit is factory installed in an all-weather metal enclosure and **is intended exclusively for outdoor installation** using only diesel fuel.

When properly sized, the generator is suitable for supplying typical residential/commercial loads, such as induction motors (sump pumps, refrigerators, freezers, air conditioners, furnaces, etc.), electronic components (computers, monitors, televisions, etc.), lighting, microwaves, and other residential and business loads.

READ THIS MANUAL THOROUGHLY: The operator is responsible for proper and safe use of this equipment. Read and thoroughly understand the contents of this manual before attempting to use the equipment. If any portion of this manual is not fully understood, contact the nearest Authorized Service Dealer for assistance.

SAVE THESE INSTRUCTIONS: The manufacturer suggests that this manual and the rules for safe operation be copied and posted near the generator installation site. Safety should be stressed to all operators and potential operators of this equipment.

SAFETY: Throughout this manual, and on tags and decals affixed to the unit, DANGER, WARNING, CAUTION and NOTE blocks are used to alert personnel to special instructions about a particular operation, function or service that may be hazardous if performed incorrectly or carelessly. Observe them carefully. Their definitions are as follows:

⚠ DANGER!

INDICATES A HAZARDOUS SITUATION OR ACTION WHICH, IF NOT AVOIDED, WILL RESULT IN DEATH OR SERIOUS INJURY.

⚠ WARNING!

Indicates a hazardous situation or action which, if not avoided, could result in death or serious injury.

⚠ CAUTION!

Indicates a hazardous situation which, if not avoided, could result in minor or moderate injury.

NOTE: Notes contain additional information important to an operation or procedure.

Four commonly used safety symbols accompany the DANGER, WARNING and CAUTION blocks. The type of information each indicates is as follows:



This symbol points out important Safety Information that, if not followed, could endanger personal safety and/or property of others.



This symbol points out a potential Explosion Hazard.



This symbol points out a potential Fire Hazard.









This symbol points out a potential Electrical Shock Hazard.

These “Safety Alerts” cannot eliminate the hazards that they signal. Strict compliance with these special instructions, plus common sense, are major accident prevention measures.

1.2 — Safety Information

Study these safety rules carefully before operating or servicing this equipment. Become familiar with this Owner's Manual and with the unit. The generator can operate safely, efficiently and reliably only if it is properly installed, operated and maintained. Many accidents are caused by failing to follow simple rules or precautions.

The manufacturer cannot anticipate every possible circumstance that might involve a hazard. The warnings in this manual, and on tags and decals affixed to the unit are not all-inclusive. If using a procedure, work method or operating technique the manufacturer does not specifically recommend, ensure that it is safe for personnel. Also make sure the procedure, work method or operating technique used does not render the generator unsafe.

-  **Despite the safe design of this generator, operating this equipment imprudently, neglecting its maintenance or being careless can cause possible injury or death. Permit only responsible and capable persons to install, operate and maintain this equipment.**
-  **Potentially lethal voltages are generated by these machines. Ensure steps are taken to make the machine safe before attempting to work on the generator.**
-  **Parts of the generator are rotating and/or hot during operation. Exercise care near a running generator.**
-  **The installation of this generator must always comply with applicable codes, standards, laws and regulations.**
-  **A running generator gives off DEADLY carbon monoxide, an odorless, colorless, poisonous gas. Breathing carbon monoxide can cause dizziness, throbbing temples, nausea, muscular twitching, headache, vomiting, weakness, sleepiness, inability to think clearly, fainting, unconsciousness or even death.**
-  **The control panel for this unit is intended to be operated by qualified service personnel only.**

1.3 — General Hazards

- For safety reasons, this equipment should only be installed, serviced and repaired by a Service Dealer or other competent, qualified electrician or installation technician who is familiar with applicable codes, standards, regulations and product Installation Manual guidelines. The operator also must comply with all such codes, standards, regulations and product Installation Manual guidelines.
- The engine exhaust fumes contain carbon monoxide, which can be DEADLY. This dangerous gas, if breathed in sufficient concentrations, can cause unconsciousness or even death. DO NOT alter or add to the exhaust system or do anything that might render the system unsafe or in noncompliance with applicable codes and standards.
- Install a carbon monoxide alarm indoors, according to manufacturer's instructions/recommendations.
- Adequate, unobstructed flow of cooling and ventilating air is critical for correct generator operation. Do not alter the installation or permit even partial blockage of ventilation provisions, as this can seriously affect safe operation of the generator. The generator MUST be installed and operated outdoors only.
- Keep hands, feet, clothing, etc. away from drive belts, fans, and other moving or hot parts. Never remove any drive belt or fan guard while the unit is operating.
- When working on this equipment, remain alert at all times. Never work on the equipment when physically or mentally fatigued.
- Inspect the generator regularly, and contact the nearest Dealer for parts needing repair or replacement.
- Before performing any maintenance on the generator, remove the control panel fuse and disconnect the Negative (-) battery cable to prevent accidental startup. When disconnecting battery cables always remove the NEGATIVE (-) cable first. When reconnecting the cables, connect the POSITIVE (+) cable first.
- Never use the generator or any of its parts as a step. Stepping on the unit can stress and break parts, and may result in dangerous operating conditions from leaking exhaust gases, fuel leakage, oil leakage, etc.

1.4 — Exhaust Hazards

- Generator engine exhaust contains DEADLY carbon monoxide, an odorless, colorless, poisonous gas. Breathing carbon monoxide can cause dizziness, throbbing temples, nausea, muscular twitching, headache, vomiting, weakness, sleepiness, inability to think clearly, fainting, unconsciousness or even death. If any carbon monoxide poisoning symptom is experienced, move into fresh air and immediately seek medical attention.
- This generator is designed for OUTDOOR installation ONLY. Never operate the generator inside any garage or other enclosed space.

1.5 — Electrical Hazards

- All generators covered by this manual produce dangerous electrical voltages that can cause fatal electrical shock. Utility power delivers extremely high and dangerous voltages to the transfer switch, as does the standby generator when it is in operation. Avoid contact with bare wires, terminals, connections, etc. while the unit is running. Ensure all appropriate covers, guards and barriers are in place, secured and/or locked before operating the generator. If work must be done around an operating unit, stand on an insulated, dry surface to reduce potential shock hazard.
- Do not handle any kind of electrical device while standing in water, while barefoot, or while hands or feet are wet. DANGEROUS ELECTRICAL SHOCK MAY RESULT.
- The generator may crank and start at any time when utility power is lost. When this occurs, load circuits are transferred to the STANDBY (generator) power source. Before working on the generator, always move the Main Circuit Breaker switch on the control panel down to the OFF (Open) position, press the OFF key on the control panel keypad, remove the 7.5 amp fuse, and disconnect the battery negative cable (black) from the battery negative (-) terminal.
- In case of accident caused by electric shock, immediately shut down the source of electrical power. If this is not possible, attempt to free the victim from the live conductor. AVOID DIRECT CONTACT WITH THE VICTIM. Use a nonconducting implement, such as a dry rope or board, to free the victim from the live conductor. If the victim is unconscious, apply first aid and get immediate medical help.
- Never wear jewelry when working on this equipment. Jewelry can conduct electricity resulting in electric shock, or may get caught in moving parts resulting in injury.

1.6 — Fire Hazards

- For fire safety, the generator must be installed and maintained properly. Installation MUST always comply with applicable codes, standards, laws, regulations and product Installation Manual guidelines. Adhere strictly to local, state, and national electrical and building codes. Comply with regulations of the Occupational Safety and Health Administration (OSHA). Also, ensure that the generator is installed in accordance with the manufacturer's instructions and recommendations. Following proper installation, do nothing that might alter a safe installation and render the unit in noncompliance with the aforementioned codes, standards, laws and regulations.
- Keep a fire extinguisher near the generator at all times. Extinguishers rated "ABC" by the National Fire Protection Association are appropriate for use on the standby generator. Keep the extinguisher properly charged and be familiar with its use. Consult the local fire department with any questions pertaining to fire extinguishers.

1.7 — Explosion Hazards

- Do not smoke around the generator. Wipe up any fuel or oil spills immediately. Ensure that no combustible materials are left in the generator compartment, or on or near the generator as FIRE or EXPLOSION may result. Keep the area surrounding the generator clean and free from debris.

⚠ WARNING!



If this generator is used to power electrical load circuits normally powered by a utility power source, it is required by code to install a transfer switch. The transfer switch must effectively isolate the electrical system from the utility distribution system when the generator is operating (NEC 702). Failure to isolate an electrical system by such means will result in damage to the generator and also may result in injury or death to utility power workers due to backfeed of electrical energy.

This page intentionally left blank.

Section 2 Specifications

2.1 — Emission Information

The U.S. Environmental Protection Agency (EPA) requires that the generator comply with exhaust emission standards. The generator is certified to meet the applicable EPA emission levels, and is certified for use as a stationary engine for standby power generation. Any other use may be a violation of federal and/or local laws. To ensure that the engine complies with the applicable emission standards for the duration of the engine's life, it is important to follow the maintenance specifications in Section 5. This generator is certified to operate on Diesel Fuel No. 2 (KSM2610).

2.1.1— Emissions Data Plate

A data plate is riveted to the cylinder head cover to verify compliance with EPA emissions regulations.

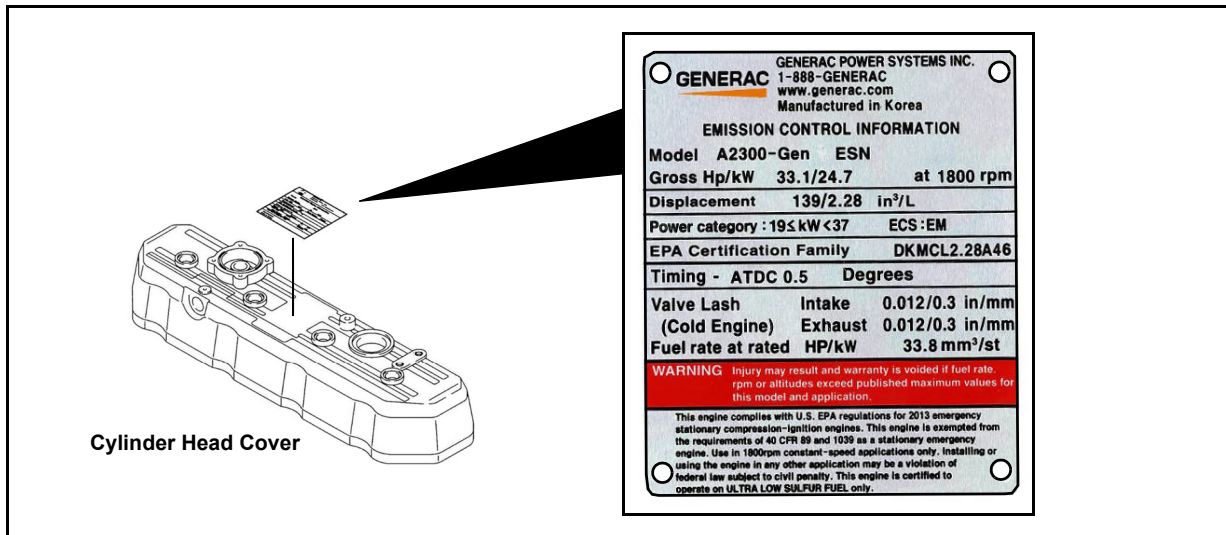

Figure 2-1. Emissions Data Plate (Sample)

2.2 — Specifications

2.2.1— Engine

General	2.3L Engine	2.4L-49 Engine	3.4L Engine
Engine System			
Type	4 cylinder, in-line, 4 cycle	4 cylinder, in-line, 4 cycle	4 cylinder, in-line, 4 cycle
Fuel Type	Ultra Low Sulfur Diesel	Ultra Low Sulfur Diesel	Ultra Low Sulfur Diesel
Fuel Filtering	5 Microns	5 Microns	10 Microns
Bore and Stroke	3.46 in x 3.70 in (88 mm x 94 mm)	3.54 in x 3.70 in (90 mm x 94 mm)	3.86 in x 4.45 in (98 mm x 113 mm)
Displacement	139.5 cubic inches (2.286 liter)	146 cubic inches (2.392 liter)	208.3 cubic inches (3.41 liter)
Firing Order	1-3-4-2	1-3-4-2	1-3-4-2
Direction or Rotation	CCW - As Viewed From Flywheel	CCW - As Viewed From Flywheel	CCW - As Viewed From Flywheel
Dimensions L x W x H	685 x 491 x 636 mm (26.97 in x 19.33 in x 25.04 in)	677.1 x 497.8 x 721.3 mm (26.66 in x 19.60 in x 28.40 in)	742 x 587 x 721 mm (29.21 in x 23.11 in x 28.39 in)
Dry Weight	441 lbs (200 kgs)	573 lbs (260 kgs)	551 lbs (250 kgs)
Compression Ratio	21.3 : 1	21.3 : 1	18.5 : 1
Cooling System			
Water Pump	Pre-Lubed, Self-Sealing	Pre-Lubed, Self-Sealing	Pre-Lubed, Self-Sealing
Drive	Belt	Belt	Belt
Thermostat	Full Open Temperature: 185° F (85° C)	Full Open Temperature: 185° F (85° C)	Full Open Temperature: 185° F (85° C)
System Coolant Capacity	2.8 gal (10.6 liter)	2.8 gal (10.6 liter)	2.8 gal (10.6 liter)
Coolant Flow Rate	10 gal (38 liter)/min at 1800 RPM	10 gal (38 liter)/min at 1800 RPM	12.2 gal (46 liter)/min at 1800 RPM
Lubricating System			
Oil Pump Type	Gear	Gear	Gear
Oil Filter Type	Full Flow Spin-On Canister	Full Flow Spin-On Canister	Full Flow Spin-On Canister
Oil Cooler	Not Applicable	Installed	Installed
Crankcase Capacity	6.87 qt. (6.5 liter)	6.8 qt. (6.4 liter)	7.4 qt. (7.0 liter)
Lubricating Oil	15W-40	15W-40	15W-40
Oil Fill Location	Filler Cap on Valve Cover and/or Front Engine Cover	Filler Cap on Valve Cover and/or Front Engine Cover	Filler Cap on Valve Cover and/or Front Engine Cover
Oil Drain Location	Oil Pan, Bottom Side	Oil Pan, Bottom Side	Oil Pan, Front
Intake and Exhaust System			
Intake Air System	Naturally Aspirated	Turbocharged	Turbocharged/Aftercooled
Maximum Allowable Intake Restriction	25 in. of Water (6.23 kPa)	25 in. of Water (6.23 kPa)	25 in. of Water (6.23 kPa)
Maximum Allowable Exhaust Back Pressure	23.6 in. of Water (5.88 kPa)	23.6 in. of Water (5.88 kPa)	24 in of Water (5.98 kPa)
Breather	Closed Crankcase System	Open Crankcase System	Open Crankcase System
Other Specifications			
Operating Temperature Range	-20° F to 120° F (-29° C to 49° C)	-20° F to 120° F (-29° C to 49° C)	-20° F to 120° F (-29° C to 49° C)
POWER ADJUSTMENT FOR AMBIENT CONDITIONS			
Temperature Deration 3% for every 5 °C above 25 °C or 1.7% for every 5 °F above 77 °F		
Altitude Deration (15, 30, 48 & 50 kW) 1% for every 100 m above 915 m or 3% for every 1000 ft above 3000 ft		
Altitude Deration (20 kW) 1% for every 100 m above 305 m or 3% for every 1000 ft above 1000 ft		

A complete specification sheet is included in the documentation provided with the unit at the time of purchase. For additional copies, consult your local Authorized Service Dealer.

2.3 — Engine Oil Recommendations

To maintain the product warranty, use only genuine Generac replacement parts. Generac maintenance kits include both the oil filter and air filter, and can be obtained through any Authorized Dealer.

All Generac maintenance kits meet minimum American Petroleum Institute (API) Service Class CD or better. Select the appropriate viscosity oil grade according to the expected operating temperature. After break-in, synthetic oil also can be used in the appropriate weight as standard. Once synthetic oil is used, it should be used for the life of the generator. It is not recommended to go back to a mineral oil. Do not use special additives.

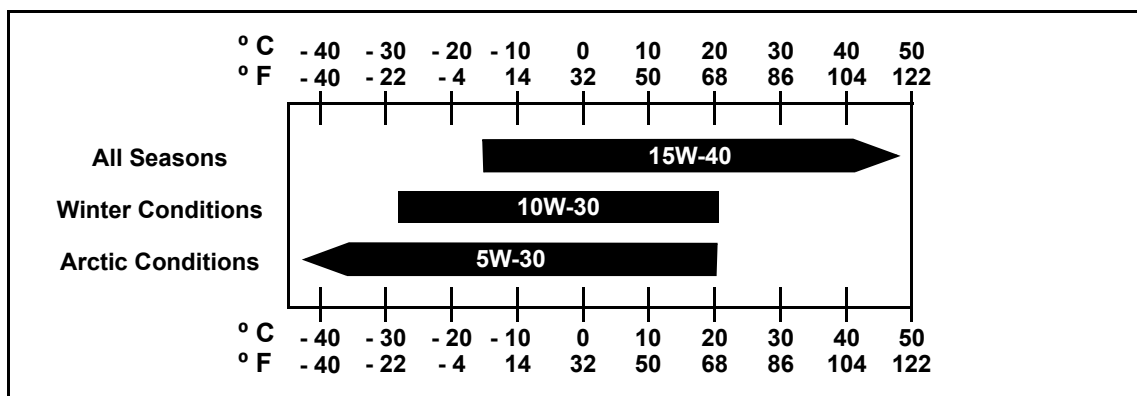

Figure 2-2. Lubricating Oil Recommendations

2.4 — Coolant Water Treatment

Use of improper coolants can damage the engine cooling system. Use demineralized water or distilled water for best results. Hard water causes scale deposits, which reduces cooling efficiency and raises internal temperatures, possibly leading to engine damage. Use an anti-corrosive to prevent rot in summer and anti-freeze to prevent freezing in winter. Dilute the anti-freeze based on a theoretical temperature that is 9-18°F (5-10°C) below the lowest temperature expected in the area. A ratio of 40-60% is most common range.

Freezing Point °F (°C)	-13 (-25)	-31 (-35)	-58 (-50)
Coolant (% Volume)	40	50	60
Water (% Volume)	60	50	40

NOTE: Use only Peak Fleet-Charge® 50/50 ethylene glycol type coolant (available from any authorized dealer).

⚠ CAUTION!



Do not use propylene glycol type coolant. Using the wrong coolant, mixing different types of coolant, or even mixing different brands of the correct type of coolant, can produce unsatisfactory results, possibly leading to engine damage.

2.5 — Fuel Requirements

IMPORTANT! DO NOT use Home Heating Oil or Bio-Diesel Fuel.

Use **No. 2D** diesel fuel when temperatures are above freezing. When temperatures are below freezing, blend **No.1D** diesel fuel and **No. 2D** diesel fuel together for a climate adjusted fuel ratio.

Starting October 1, 2010, diesel fuel must also meet the following requirements:

- Sulfur content of 15 parts per million (ppm) maximum.
- Minimum Cetane index of 40.

NOTE: Low ambient temperatures as well as engine operation at high altitudes may require the use of fuels with higher Cetane ratings.

Allow at least 5 percent of the tank capacity for fuel expansion. **DO NOT OVERFILL!**

2.5.1— Fuel Maintenance

Always treat diesel fuel for long term storage. Use the approved fuel additive and water abatement material. Test stored fuel every 90 days and provide additional treatment if required. Periodically check and dry abatement material as necessary.

2.5.2— Fuel Maintenance

Always treat diesel fuel for long term storage. Use the approved fuel additive and water abatement material. Test stored fuel every 90 days and provide additional treatment if required. Periodically check and dry abatement material as necessary.

2.6 — Battery Requirements

Group 27F, 12 Volt	2.3L Engine: For areas where temperatures regularly drop below 32° F (0° C).
NOTE: Battery dimensions (L x W x H) for Group 27F battery must not exceed 12-1/2" x 6-13/16" x 8-15/16" (318 mm x 173 mm x 227 mm).	
Group 31, 12 Volt	2.4L-49 Engine: For areas where temperatures regularly drop below 32° F (0° C).
NOTE: Battery dimensions (L x W x H) for Group 31 battery must not exceed 13" x 6-13/16" x 9-7/16" (330 mm x 173 mm x 240 mm).	

2.6.1— Battery Charger

The battery charger is integrated into the control panel module. It operates as a “Smart Charger” which ensures output charging levels are safe and continuously optimized to promote maximum battery life.

2.7 — Corrosion Protection

Periodically wash and wax the enclosure using automotive type products. Frequent washing is recommended in salt water/coastal areas.

2.8 — Accessories

The following product accessories are available. Contact a Dealer for additional information.

- | | |
|---|---|
| 1. Scheduled Maintenance Kit (Part No. 006572-0; 15/20 kW) | 8. Emergency Stop Switch (Part No. 006510-0) |
| 2. Scheduled Maintenance Kit (Part No. 006571-0; 30 kW) | 9. Touch-Up Paint Kit (Part No. 005704-0) |
| 3. Scheduled Maintenance Kit (Part No. 006570-0; 50 kW) | 10. Five Gallon Spill Box (Part No. 006502-0) |
| 4. Cold Weather Kit (Part No. 006560-0: 15/20 kW; Part No. 006559-0: 30 kW; Part No. 006558-0: 50 kW) | 11. Fuel Tank Risers (Part No. 006505-0: 15/20 kW; Part No. 006506-0: 30/50 kW) |
| 5. Vent Extension Support Kit (Part No. 006588-1) | 12. 90% Fuel Fill Level Alarm (Part No. 006504-0) |
| 6. Fuel Fill Drop Tube (Part No. 006507-0) | 13. Spill Box Drain Back (Part No. 006511-0) |
| 7. Lockable Fuel Fill Cap (Part No. 006512-0) | 14. Stainless Steel Fuel Lines (Part No. 006513-0:15/20 kW; Part No. 006517-0: 30 kW; Part No. 006516-0: 50 kW) |



Figure 2-3. Product Accessories

This page intentionally left blank.

Section 3 *Activation and Startup*

IMPORTANT NOTE: The unit fuel tank has been inspected by AHJ (authority having local jurisdiction) or fire marshal and meets all requirements. Unit is fueled and the fuel is treated as per additive directions.

3.1 — Orientation

NOTE: The 3.4L engine is depicted in the artwork used in this manual. The location and appearance of some components may vary between engine models.

The side of the enclosure with the viewing window is identified as the rear of the generator set. The right and left sides are identified by standing at the rear and looking towards the front of the unit.

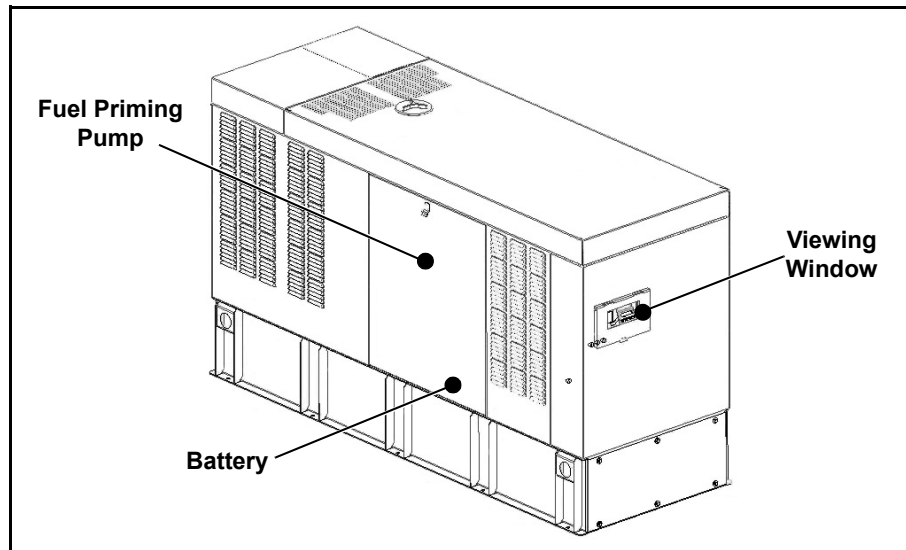

Figure 3-1. Enclosure (Rear Left View)

3.2 — Remove Side Access Panels

NOTE: Access panels are located at both the front and sides of the enclosure.

1. Insert key into latch and rotate counterclockwise 1/2 turn. See Figure 3-2.
2. Raise panel using thumb latch.

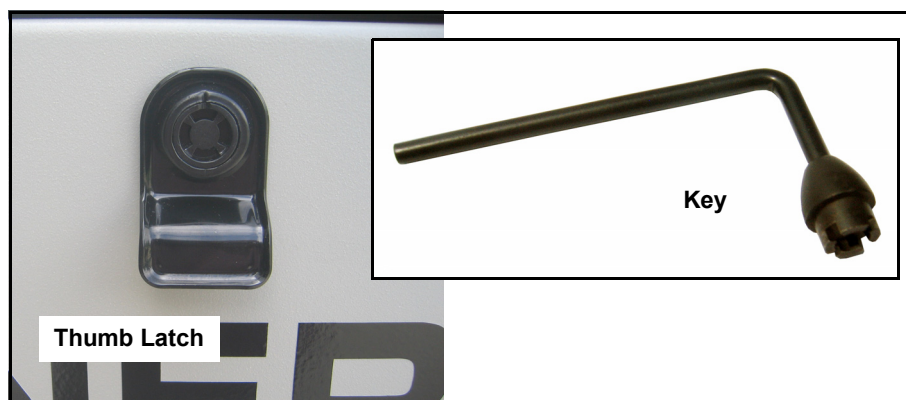

Figure 3-2. Access Panel Key

3.3 — Prime Fuel System

1. See Figure 3-3. Loosen the air bleed screw and work priming pump until bubbles are observed. Place a shop rag around the air bleed screw to catch any loss of fuel.
2. When all bubbles are purged and replaced by a solid stream of fuel, tighten the air bleed screw.
3. Check for leaks.

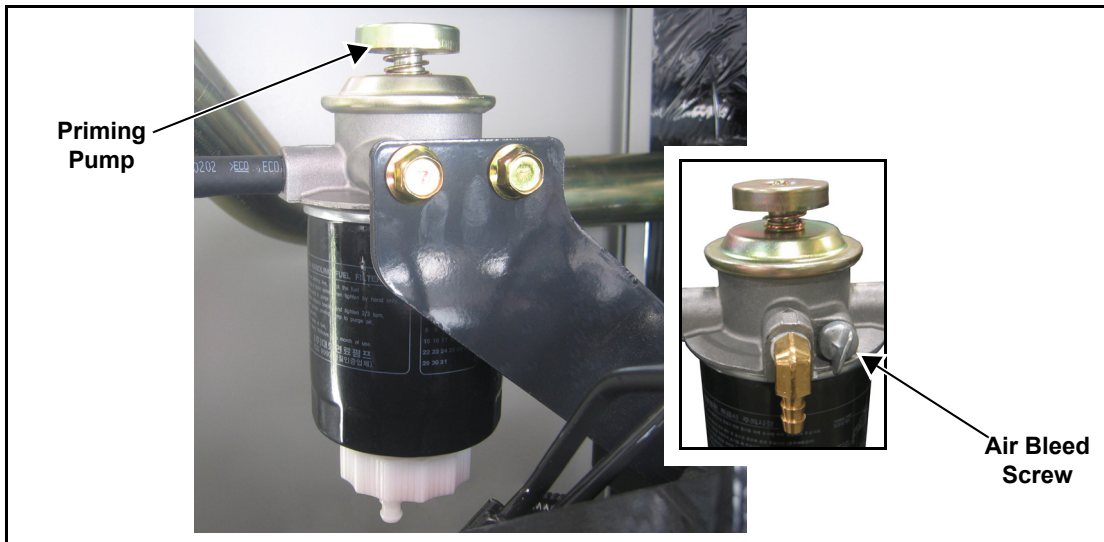

Figure 3-3. Prime Fuel System

3.4 — Install Battery



CAUTION: Always connect the positive battery cable first. If the positive cable should contact ground with the negative cable installed, the resulting sparks may cause a battery explosion which could result in serious injury.

2.4L/3.4L Models

NOTE: On 2.3L models, remove ten screws to release louvered air intake panel on left side of enclosure.

1. Loosen two screws with nylon washers to release hold-down clamp from battery tray.
2. Install battery onto tray.
3. Install two screws with nylon washers to secure hold-down clamp to battery tray.
4. Install battery positive cable (red) to battery positive (+) terminal.
5. Install battery negative cable (black) to battery negative (-) terminal.

NOTE: On 2.3L models, start ten screws to install louvered air intake panel. Alternately tighten screws to 90 in-lbs (10 N-m) using a crosswise pattern.

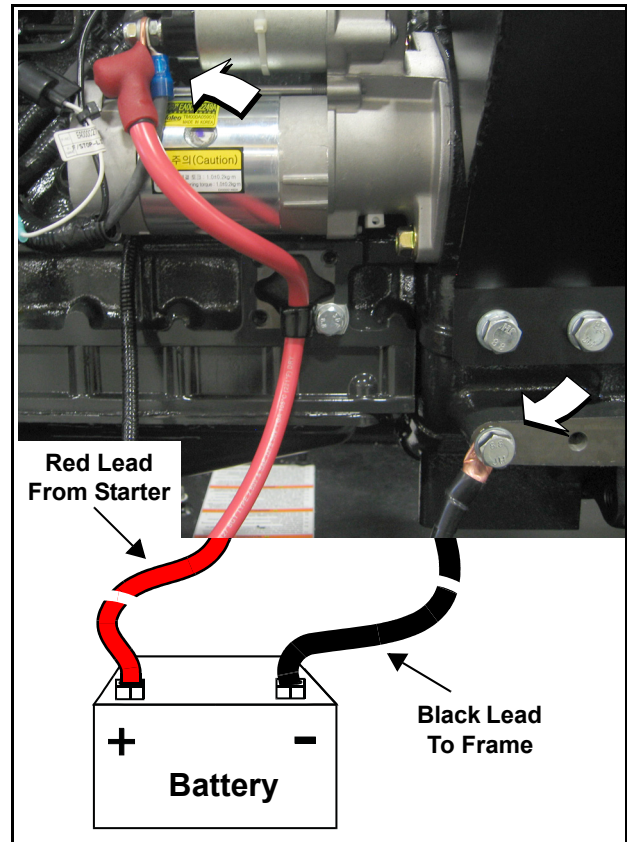

Figure 3-4. Battery Cable Connections

3.5 — Open Viewing Window

1. Rotate viewing window upward to access control panel.
2. To hold viewing window in the open position, remove rod from clip at back of window and insert into hole in frame. See Figure 3-5.



Figure 3-5. Viewing Window

3.6 — Start and Run Engine

1. Pull up rubber flap covering fuse holder and verify installation of 7.5 amp fuse. See A of Figure 3-6.
2. Move the Main Circuit Breaker switch down to the OFF (Open) position. See B of Figure 3-6.
3. Press MANUAL on the control pad to start the engine. A blue LED illuminates to confirm that the system is in the MANUAL mode. See C of Figure 3-6.
4. Allow the engine to run until it reaches normal operating temperature.
5. Press OFF on the control pad to stop the engine. A red LED illuminates to confirm that the system is in the OFF mode.

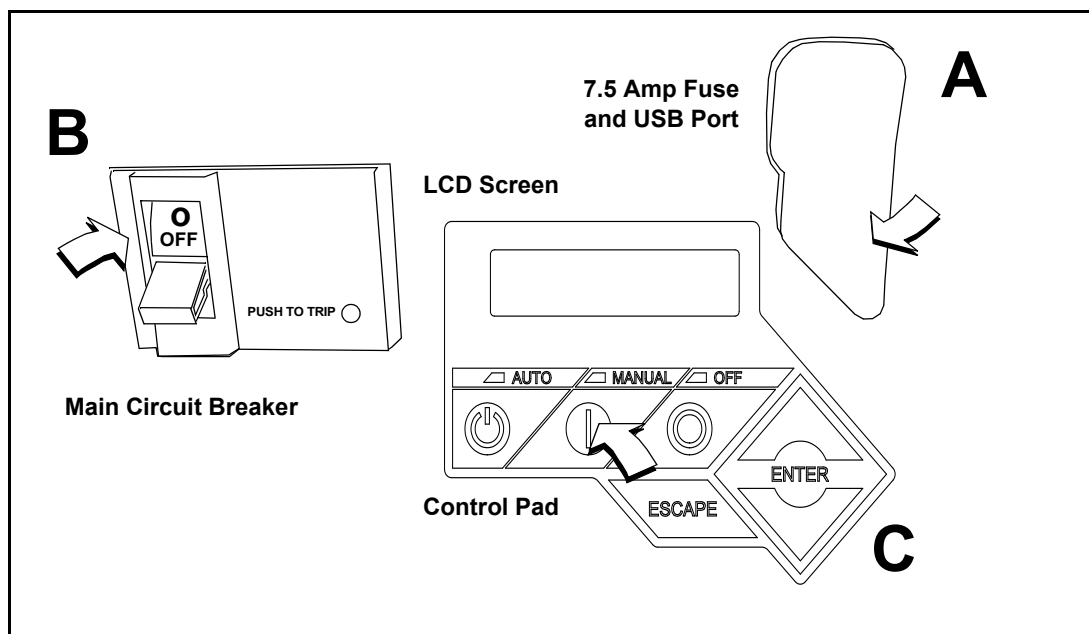
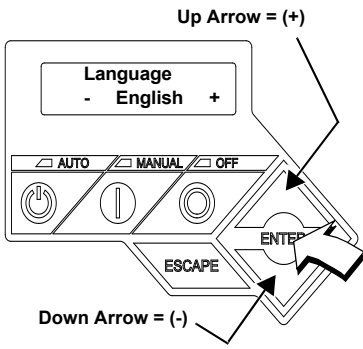

Figure 3-6. Generator Control Panel

3.7 — Activate Unit

<p>Display Reads:</p> 	<p>Generator Active is displayed on the LCD screen when the unit is first powered up. After displaying firmware and hardware version codes, as well as other system information, the Installation Wizard is launched, and the Language screen is displayed.</p> <p>Use UP ARROW or DOWN ARROW to scroll to desired language.</p> <p>Press ENTER.</p>	<p>If the wrong language is selected, it may be changed later using the Edit menu.</p>
<p>Display Reads:</p> <div style="border: 1px solid black; padding: 5px; text-align: center;"> <p>Activate me (ENT) or ESC to run in manual</p> </div>	<p>Press ENTER.</p>	<p>Press ESCAPE to abort the activation sequence. NOT ACTIVATED is displayed and the generator will run in manual mode only. Disconnect and reconnect the negative battery cable to restart the activation routine. If power is removed after a successful activation, no data is lost, but the time and date must be updated.</p>
<p>Display Reads:</p> <div style="border: 1px solid black; padding: 5px; text-align: center;"> <p>To Activate go to www.activategen.com</p> </div>	<p>Go to www.activategen.com or call 1-888-9ACTIVATE (922-8482, US & CA only) if activation passcode is not available.</p> <p>If activation pass code is available, wait a few seconds for the next display.</p>	
<p>Display Reads:</p> <div style="border: 1px solid black; padding: 5px; text-align: center;"> <p>SN 1234567890 PASS CODE XXXXX</p> </div>	<p>Use UP ARROW or DOWN ARROW to increment or decrement the digit to correspond to the first number of the pass code.</p> <p>Press ENTER.</p> <p>Repeat step to enter remaining digits.</p>	<p>Press ESCAPE to return to preceding digits if a correction becomes necessary.</p> <p>If attempts to enter the activation code are unsuccessful, check the number against the code given on activategen.com. If it is correct, contact 1-888-9ACTIVATE (922-8482, US & CA only).</p>
<p>Display Reads:</p> <div style="border: 1px solid black; padding: 5px; text-align: center;"> <p>Select Hour (0-23) - 6 +</p> </div>	<p>Use UP ARROW or DOWN ARROW to increment or decrement the hour. Press ENTER.</p> <p>Use UP ARROW or DOWN ARROW to increment or decrement the minute. Press ENTER.</p> <p>Use UP ARROW or DOWN ARROW to select the month. Press ENTER.</p> <p>Use UP ARROW or DOWN ARROW to increment or decrement the date. Press ENTER.</p> <p>Use UP ARROW or DOWN ARROW to increment or decrement the year. Press ENTER.</p>	

<p>Display Reads:</p> <div style="border: 1px solid black; padding: 10px; text-align: center;"> <p>Quite Test Mode? Yes No</p> </div>	<p>Use UP ARROW or DOWN ARROW to select either Yes or No.</p> <p>Press ENTER.</p>	<p>Select YES to perform exercise at low speed. Select NO to perform exercise at normal operating speed.</p>
<p>Display Reads:</p> <div style="border: 1px solid black; padding: 10px; text-align: center;"> <p>Select Hour (0-23) - 1 +</p> </div>	<p>Set Exercise Time.</p> <p>Use UP ARROW or DOWN ARROW to increment or decrement the hour. Press ENTER.</p> <p>Use UP ARROW or DOWN ARROW to increment or decrement the minute. Press ENTER.</p> <p>Use UP ARROW or DOWN ARROW to scroll to the day of the week. Press ENTER.</p>	<p>In the AUTO mode, the engine starts and runs once each week at the time and day specified. During the exercise cycle, the unit runs approximately 12 minutes and then shuts down. Transfer of loads to the generator does not occur unless utility power fails.</p>

3.8 — Operational Checks

⚠ CAUTION!



The following procedures require special tools and skills. Contact a Generac Dealer or an authorized service provider to perform these tasks.

3.8.1— Self Test

Upon power up, the controller goes through a system self test which checks for the presence of utility voltage on the DC circuits. This is done to prevent damage if the installer mistakenly connects AC utility power sense wires into the DC terminal block. If utility voltage is detected, the controller displays a warning message and locks out the generator, thereby preventing damage to the controller. Remove power to the controller to clear this warning.

Utility voltage must be turned on and present at the N1 and N2 terminals inside the generator control panel for this test to be performed and pass.

Before starting, complete the following:

1. Verify that the generator is OFF. A red LED on the control pad illuminates to confirm that the system is in the OFF mode.
2. Verify that the Main Circuit Breaker switch on the generator control panel is in the OFF (Open) position.
3. Turn off all circuit breakers/electrical loads that will be powered by the generator.
4. Check the fuel level, coolant level, and engine lubricating oil level. See Subsections 5.7.2, 5.7.4, and 5.7.6, respectively.

During initial start up only, the generator may exceed the normal number of start attempts and experience an “over crank” fault. This is due to accumulated air in the fuel system during installation. Reset the control board and restart up to two more times, if necessary. If unit fails to start, contact the local dealer for assistance.

3.8.2— Check Manual Transfer Switch Operation

Refer to the manufacturer’s instructions.

⚠ DANGER!



Do not attempt manual transfer switch operation until all power voltage supplies to the transfer switch have been positively turned off. Failure to turn off all power voltage supplies will result in extremely hazardous and possibly fatal electrical shock.

3.8.3— Electrical Checks

Complete electrical checks as follows:

1. Verify that the generator is OFF. A red LED on the control pad illuminates to confirm that the system is in the OFF mode.
2. Verify that the Main Circuit Breaker switch on the generator control panel is in the OFF (Open) position.
3. Turn OFF all circuit breakers/electrical loads that will be powered by the generator.
4. Turn on the utility power supply to the transfer switch using the means provided (such as a utility main line circuit breaker).

⚠ DANGER!



The transfer switch is now electrically “hot.” Contact with “hot” parts will result in extremely hazardous and possibly fatal electrical shock.

5. Use an accurate AC voltmeter to check utility power source voltage across transfer switch terminals N1, N2, and N3 (if three phase). Normal line-to-line voltage should be equivalent to rated unit voltage.
6. Check utility power source voltage across terminals N1, N2, and N3 (if three phase) and the transfer switch neutral lug.
7. When certain that utility supply voltage is compatible with transfer switch and load circuit ratings, turn OFF the utility power supply to the transfer switch.
8. Press MANUAL on the control pad to crank and start the engine.
9. Allow the engine to warm up for about five minutes. Move the Main Circuit Breaker switch on the generator control panel up to the ON (or closed) position.

⚠ DANGER!



Generator power voltage is now supplied to the transfer switch. Contact with live transfer switch parts will result in dangerous and possibly fatal electrical shock.

10. Connect an accurate AC voltmeter and a frequency meter across transfer switch terminal lugs E1, E2, and E3 (if three phase).
11. Successively connect the AC voltmeter test leads across terminal lugs E1, E2, and E3 (if three phase) and neutral; then across E2 and neutral. Voltage reading in each case should match utility voltage reading. If system is three phase, verify that generator phase rotation matches utility phase rotation.
12. Move the Main Circuit Breaker switch on the generator control panel down to the OFF (Open) position.
13. Press OFF on the control pad to shut the engine down.

⚠ DANGER!



Do not proceed unless certain that generator AC voltage and frequency are correct and within the stated limits.

3.8.4— Test Generator Under Load

To test the generator set with electrical loads applied, proceed as follows:

1. Verify that the generator is OFF. A red LED on the control pad illuminates to confirm that the system is in the OFF mode.
2. Turn OFF all breakers/electrical loads that will be powered by the generator.
3. Turn OFF the utility power supply to the transfer switch, using the means provided (such as a utility main line circuit breaker).

⚠ DANGER!



Do not attempt manual transfer switch operation until all power voltage supplies to the transfer switch have been positively turned off. Failure to turn off all power voltage supplies will result in extremely hazardous and possibly fatal electrical shock.

4. Manually set the transfer switch to the STANDBY position, i.e., load terminals connected to the generator’s E1, E2, and E3 (if three phase) terminals.

5. Press **MANUAL** on the control pad. The engine will crank and start.
6. Allow the engine to warm up for a few minutes.
7. Move the Main Circuit Breaker switch on the generator control panel up to the **ON** (or closed) position. The switch is now powered by the standby generator.
8. Turn **ON** the circuit breaker/electrical loads powered by the generator.
9. Connect a calibrated AC voltmeter and a frequency meter across terminal lugs E1, E2, and E3 (if three phase). Voltage should be approximately unit rated voltage. Check with clamp on amp meter to ensure unit is not overloaded.
10. Let the generator run at full rated load for 20-30 minutes. Listen for unusual noises, vibration or other indications of abnormal operation. Check for oil leaks, evidence of overheating, etc.
11. When testing under load is complete, turn **OFF** electrical loads.
12. Move the Main Circuit Breaker switch on the generator control panel up to the **OFF** (or open) position.
13. Allow the engine to run at no-load for 2-5 minutes.
14. Press **OFF** on the control pad to shut the engine down. A red LED illuminates to confirm that the system is in the **OFF** mode.

3.8.5— Check Automatic Operation

To check the system for proper automatic operation, proceed as follows:

1. Verify that the generator is **OFF**. A red LED on the control pad illuminates to confirm that the system is in the **OFF** mode.
2. Install front cover of the transfer switch.
3. Turn **ON** the utility power supply to the transfer switch, using the means provided (such as a utility main line circuit breaker).

NOTE: Transfer Switch will transfer back to utility position.

4. Move the Main Circuit Breaker switch on the generator control panel up to the **ON** (or closed) position.
5. Press **AUTO** on the control pad. The system is now ready for automatic operation.
6. Turn **OFF** the utility power supply to the transfer switch.

With the generator ready for automatic operation, the engine will crank and start when the utility source power is turned **OFF** after a 10 second delay (factory default setting). After starting, the transfer switch connects load circuits to the standby side. Let the system operate through its entire automatic sequence of operation.

With the generator running and loads powered by generator AC output, turn **ON** the utility power supply to the transfer switch. The system transfers back to the utility position and then runs through the cool down cycle and shuts down.

3.9 — Final Instructions

1. Use key to install side access panels.
2. Close viewing window.

NOTE: Obtain viewing window hasp, if not installed. See Figure 3-7. With the retaining tab at the bottom, insert square end of hasp into slot below viewing window. Push on hasp until it snaps in place. Gently pull on hasp to verify that it will not come free.

3. Install customer supplied padlock into hasp.



Figure 3-7. Install Viewing Window Hasp

This page intentionally left blank.

Section 4 Operation

4.1 — Control Panel

NOTE: The control panel is intended for use by qualified service personnel only.

The control panel is located behind the viewing window at the rear of the unit.

⚠ WARNING!



With the control pad set to **AUTO**, the engine may crank and start at any time without warning. Such automatic starting occurs during the programmed exercise cycle or when utility power source voltage drops below the configured level. To prevent possible injury that might occur during sudden starts, always set the control pad to **OFF** and remove the 7.5 amp fuse before working on or around the generator or transfer switch. For added security, place a **DO NOT OPERATE** tag or placard on both the control panel and transfer switch.

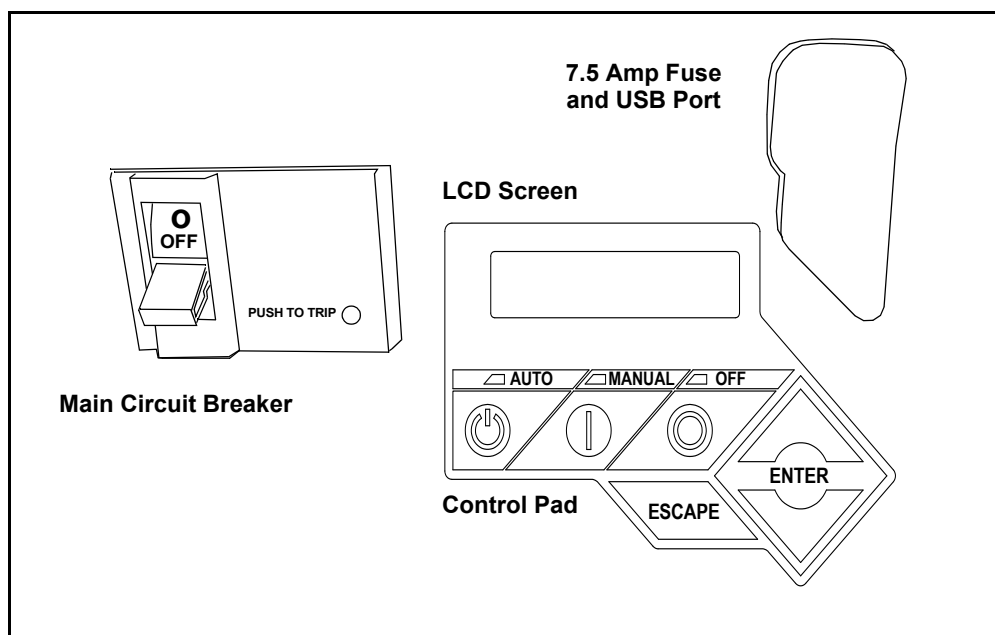

Figure 4-1. Generator Control Panel

4.2 — Auto/Manual/Off

Feature	Description
AUTO	Press to activate fully automatic operation. Green LED illuminates to confirm that system is in AUTO mode. Transfer to standby power occurs if utility power fails. Functionality of exercise timer is enabled, if set.
MANUAL	Press to crank and start engine. Blue LED illuminates to confirm that system is in MANUAL mode. Transfer to standby power occurs if utility power fails. Functionality of exercise timer is disabled.
OFF	Press to shut down engine, if running. Red LED illuminates to confirm that system is in OFF mode. Transfer to standby power does not occur if utility power fails.

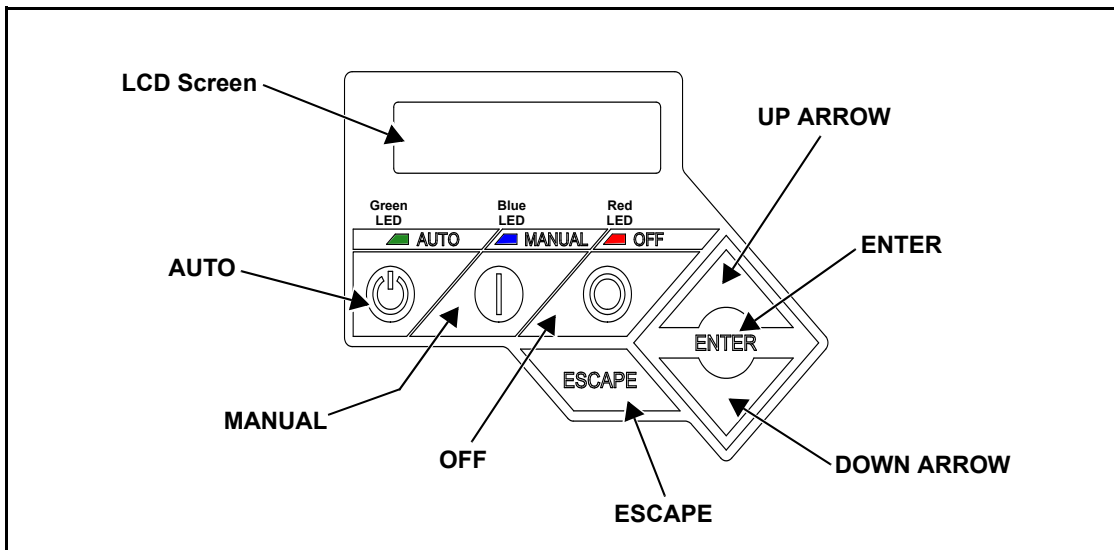

Figure 4-2. Control Pad and LCD Screen

4.3 — Menu Navigation

See Figure 4-3.

Feature	Description
System Menus	
HOME Screen	The system returns to the Home screen if the control pad is not used for five minutes. The screen normally displays a Status message, such as Ready to Run (Auto mode) or Switched to OFF (Off mode), and the total Hours of Protection. If an active alarm/warning condition occurs, the associated Alarm/Warning message is displayed. To clear the Alarm/Warning message, press OFF on the control pad followed by ENTER. In the event of multiple Alarms/Warnings, the next message is then displayed. The highest priority alarm is always displayed first.
MAIN MENU	Enables the operator to navigate the software using UP ARROW, DOWN ARROW, ENTER and ESCAPE. The Main Menu can be accessed from any sub menu by consecutively pressing ESCAPE. Each time ESCAPE is pressed, the preceding menu is displayed. The Main Menu is reached when the System, Date/Time, Battery, and Sub Menus are displayed.
Navigation	
ESCAPE	Used to abort a routine or back up to the preceding menu.
ENTER	Used to make a selection or save an entry.
UP ARROW DOWN ARROW	Used to move forward or backward from menu to menu or to scroll forward or backward (increment or decrement) through available selections.
NOTE: Pressing the control pad illuminates the backlight for 30 seconds. The backlight also illuminates for 30 seconds whenever an active Alarm/Warning message is displayed.	

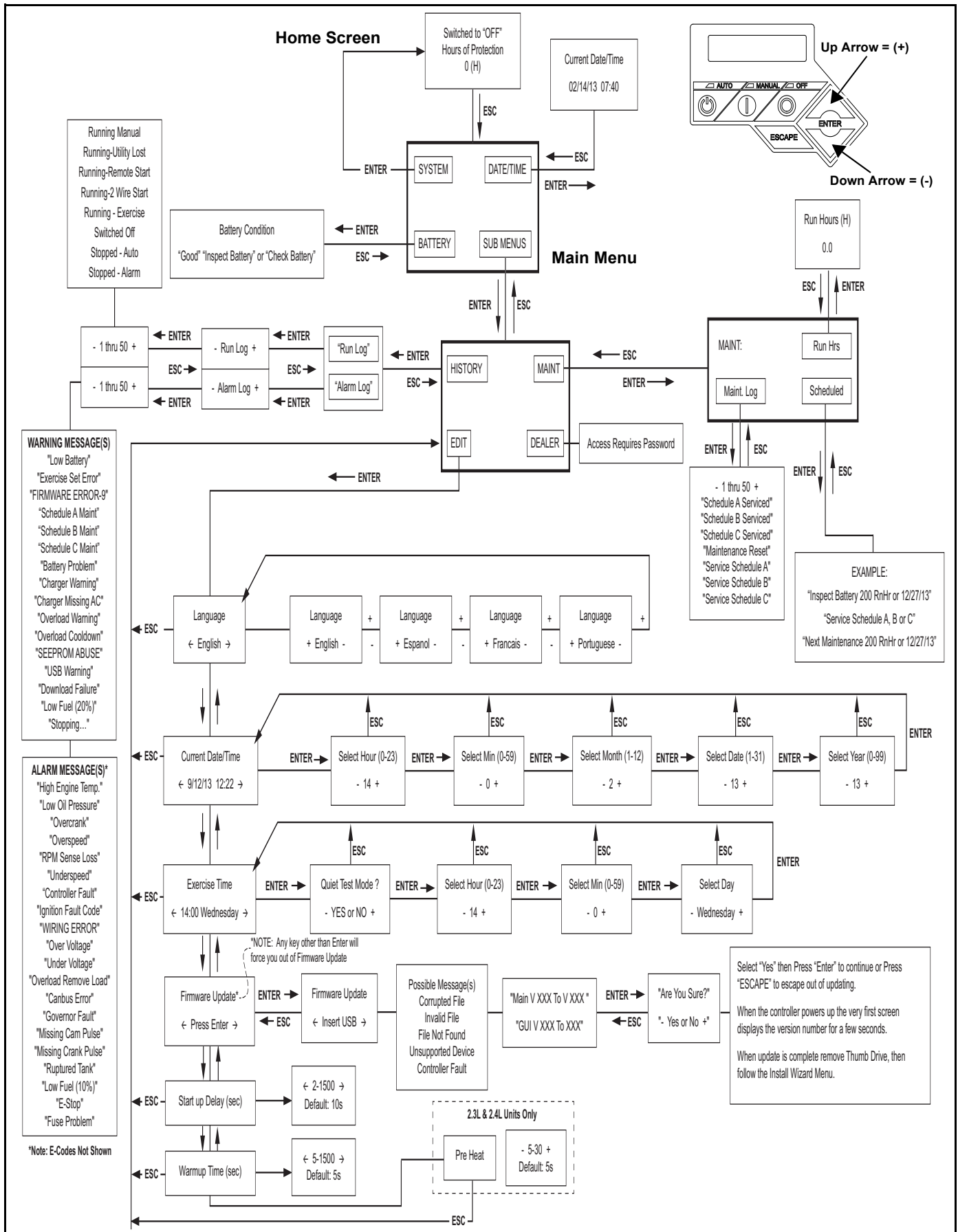

Figure 4-3. Navigation Menu

4.4 — Alarm/Warning Conditions

The owner/operator is alerted to Alarm and/or Warning conditions via the control panel LCD screen. All Alarm conditions cause the generator to shut down. The Warning messages alert the operator to conditions that do not disable the unit or require immediate correction.

The possible Alarm/Warning messages are listed below.

Alarm Messages

- High Engine Temperature
- Low Oil Pressure
- Overcrank
- Overspeed
- RPM Sense Loss
- Underspeed
- Controller Fault
- Ignition Fault Code
- WIRING ERROR
- Over Voltage
- Under Voltage
- Overload Remove Load
- Canbus Error
- Governor Fault
- Missing Cam Pulse
- Missing Crank Pulse
- Ruptured Tank
- Low Fuel (10%)
- E-Stop
- Fuse Problem

Warning Messages

- Low Battery
- Exercise Set Error
- FIRMWARE ERROR-9
- Schedule A Maintenance
- Schedule B Maintenance
- Schedule C Maintenance
- Battery Problem
- Charger Warning
- Charger Missing AC
- Overload Warning
- Overload Cooldown
- SEEPROM ABUSE
- USB Warning
- Download Failure
- Low Fuel (20%)
- Stopping...

NOTE: Unless properly trained to correct and clear Alarm/Warning conditions, contact an Authorized Dealer or trained service technician.

4.5 — Change Time and Date

To change the time and date after activation, see the Navigation Menu in Figure 4-3. If power is lost (battery is disconnected/reconnected, control panel fuse is removed/installed, etc.), the display automatically prompts the user for the Time and Date. All other information is retained in memory.

4.6 — Programmable Timers

4.6.1— Dealer Programmable

4.6.1.1—Exercise Time

A programmable exercise time is provided. In the AUTO mode, the engine starts and runs once each week at the time and day specified. During the exercise cycle, the unit runs approximately 12 minutes and then shuts down. Transfer of loads to the generator does not occur unless utility power fails.

NOTE: A Dealer password is required to change the Exercise time.

4.6.2— User Programmable

4.6.2.1—Start-Up Delay Timer

A programmable line interrupt delay (or Start-Up Delay) timer is provided. When utility voltage fails (falls below 60% of nominal), the start-up delay timer is started. If the voltage rises above the Utility Volts Low threshold, the timer is reset. If the utility voltage remains below the threshold during the duration of the timer, the unit cranks and starts.

NOTE: The factory default setting is five seconds, but is adjustable from 2 to 1500 seconds.

4.6.2.2—Warm-Up Delay Timer

A programmable Warm-Up Delay timer is provided. As soon as the generator starts, the warm-up timer is started. When the warm-up timer expires, the control transfers load to the generator (through the transfer switch) if the utility voltage is less than 80% of nominal. If utility voltage is greater than the threshold at expiration of the warm-up time, the load is **not** transferred to the generator and a cool-down period begins. At the end of the cool-down period, the generator stops.

NOTE: The factory default setting is five seconds, but is adjustable from 5 to 1500 seconds.

4.7 — USB Port for Firmware Updates

A USB port is located beneath the rubber flap on the control panel, and is provided for firmware updates. Firmware updates must be performed by an Authorized Service Dealer.

NOTE: The USB port is intended for use with a USB thumb drive only. The USB port is not intended for charging devices such as phones or laptops. Do not connect any consumer electronics to the USB port.

4.8 — Battery Charger

NOTE: The battery charger is integrated into the control panel module.

The battery charger ensures:

- Output is continually optimized to promote maximum battery life.
- Charging levels are safe.

NOTE: A warning message is displayed on the LCD screen when the battery requires service.

4.9 — Transfer Switch Automatic Operation

In AUTO, the generator starts automatically when utility source voltage drops below the preset level. Once the unit starts, loads are transferred to the standby power source.

To select automatic operation:

1. Verify that the transfer switch main contacts are set to the UTILITY position (loads connected to the utility power source).
2. Verify that normal UTILITY power source voltage is available to transfer switch terminal lugs N1, N2 and N3 (if three phase).
3. Move the Main Circuit Breaker switch on the control panel up to the ON (Closed) position.
4. Press AUTO on the control pad. A green LED illuminates to confirm that the system is in the AUTO mode.

4.9.1— Automatic Sequence of Operation

4.9.1.1—Utility Failure

If the control pad is set to AUTO when the utility power fails (falls below 60% of nominal, dealer programmable), a ten second Start-Up Delay timer is started (user programmable). If utility power is still absent when the time expires, the engine cranks and starts.

Once started, a **five** second engine Warm-Up Delay timer starts (user programmable). When the time has elapsed, the load is transferred to the generator. If utility power is restored (above 80% of nominal, dealer programmable) between the time the engine is first started and expiration of the warm-up time, the controller completes the start cycle and then runs through its normal cool-down cycle (while the load remains on the utility source throughout the episode).

4.9.1.2—Cranking

The cyclic cranking is controlled as follows:

Fifteen (15) seconds crank, seven (7) seconds rest, seven (7) seconds crank, seven (7) seconds rest; this sequence is repeated for a total of six (6) crank cycles.

4.9.1.3—Load Transfer

With the generator running, the transfer of load is dependent upon the operating mode as follows:

AUTO	<ul style="list-style-type: none"> Starts and runs if utility power fails (falls below 60% of nominal) for five consecutive seconds (adjustable). Starts a five second (adjustable) engine warm-up timer. Does not execute transfer if utility power returns before expiration of warm-up timer (but finishes the warm-up and cool-down cycles). Transfers back to utility once utility power returns (above 80% of nominal) for fifteen consecutive seconds. Only shuts down if OFF is pressed or an alarm shutdown occurs. Once utility power returns, starts a cool-down cycle before it shuts down. <p>NOTE: Cool-down cycle is five minutes if turbocharger equipped, one minute if naturally aspirated.</p>
	<p>EXERCISE</p> <ul style="list-style-type: none"> Only works in the AUTO mode. Does not exercise if generator is already running in AUTO. During exercise cycle, transfers only if utility power fails for ten consecutive seconds.
MANUAL	<ul style="list-style-type: none"> Engine cranks and runs even if utility power is present, but does not transfer to generator. Transfers to generator if utility fails (falls below 60% of nominal) for ten consecutive seconds. Transfers back to utility when utility returns for fifteen consecutive seconds. The engine continues to run until the AUTO or OFF key is pressed.

4.10 — Transfer Switch Manual Operation

⚠ DANGER!



DO NOT attempt to activate the transfer switch manually until all power voltage supplies to the switch have been completely turned off. Failure to turn off all power voltage supplies may result in extremely hazardous and possibly fatal electrical shock.

Prior to automatic operation, manually exercise the transfer switch to verify that there is no binding or interference with proper operation of the mechanism. Manual operation of the transfer switch is required if automatic operation fails.

IMPORTANT NOTE: Always use the applicable transfer switch owner's manual for actual manual transfer switch operation instructions. The information presented here describes a typical V-style transfer switch, which is not used for three phase applications.

4.10.1— Transfer to Generator Power

When utility power fails, manually transfer to standby power and start the generator as follows:

1. Press OFF on the control pad. A red LED illuminates to confirm that the system is in the OFF mode.
2. Move the Main Circuit Breaker switch down to the OFF (Open) position.
3. Turn off the utility power supply to the transfer switch using the means provided (such as a utility main line circuit breaker).
4. Use the manual transfer handle inside the transfer switch to move the main contacts to the STANDBY position (loads connected to the standby power source).
5. Press MANUAL on the control pad. The engine cranks and starts.
6. Allow the engine to run for two minutes to bring it up to normal operating temperature.
7. Move the Main Circuit Breaker switch up to the ON (Closed) position.

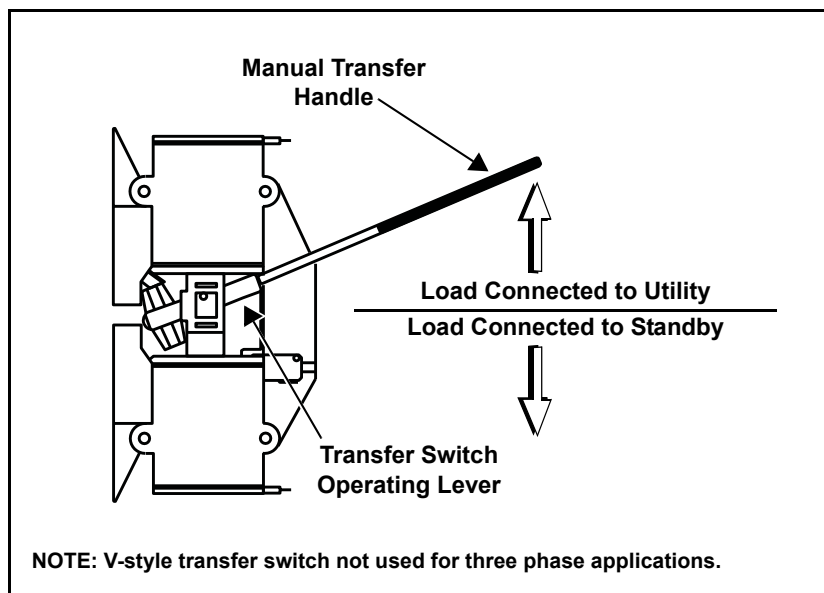

Figure 4-4. Manual Transfer Switch Operation (Typical)

4.10.2— Transfer Back to Utility Power

When utility power is restored, manually transfer back to utility power and shut down the generator as follows:

NOTE: Verify that utility voltage has returned and is at the proper value.

1. Move the Main Circuit Breaker switch down to the OFF (Open) position.
2. Allow the engine to run for two minutes at no-load to bring it up to normal operating temperature.
3. Press OFF on the control pad to shut down the engine.
4. Verify that utility power supply to the transfer switch is turned off.
5. Use the manual transfer handle inside the transfer switch to move the main contacts to the UTILITY position (loads connected to the utility power source).
6. Turn on the utility power supply to the transfer switch using the means provided.
7. Press AUTO on the control pad. A green LED illuminates to confirm that the system is in the AUTO mode.

This page intentionally left blank.

Section 5 Maintenance

5.1 — Component Locations

The side of the enclosure with the viewing window is identified as the rear of the generator set. The right and left sides are identified by standing at the rear and looking towards the front of the unit.

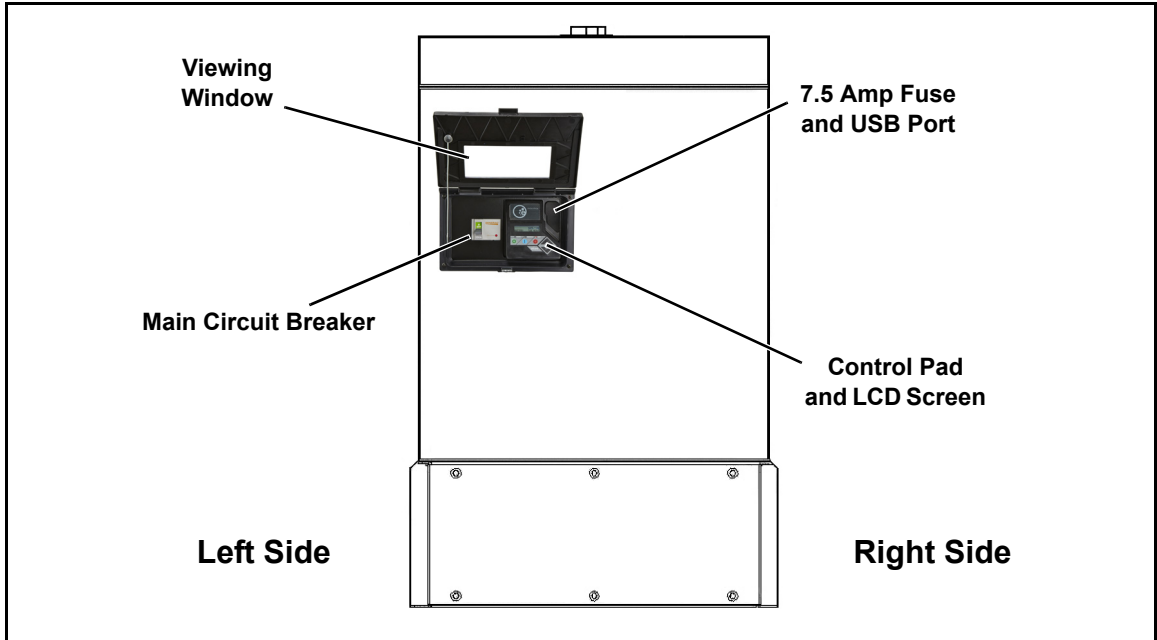

Figure 5-1. Rear View

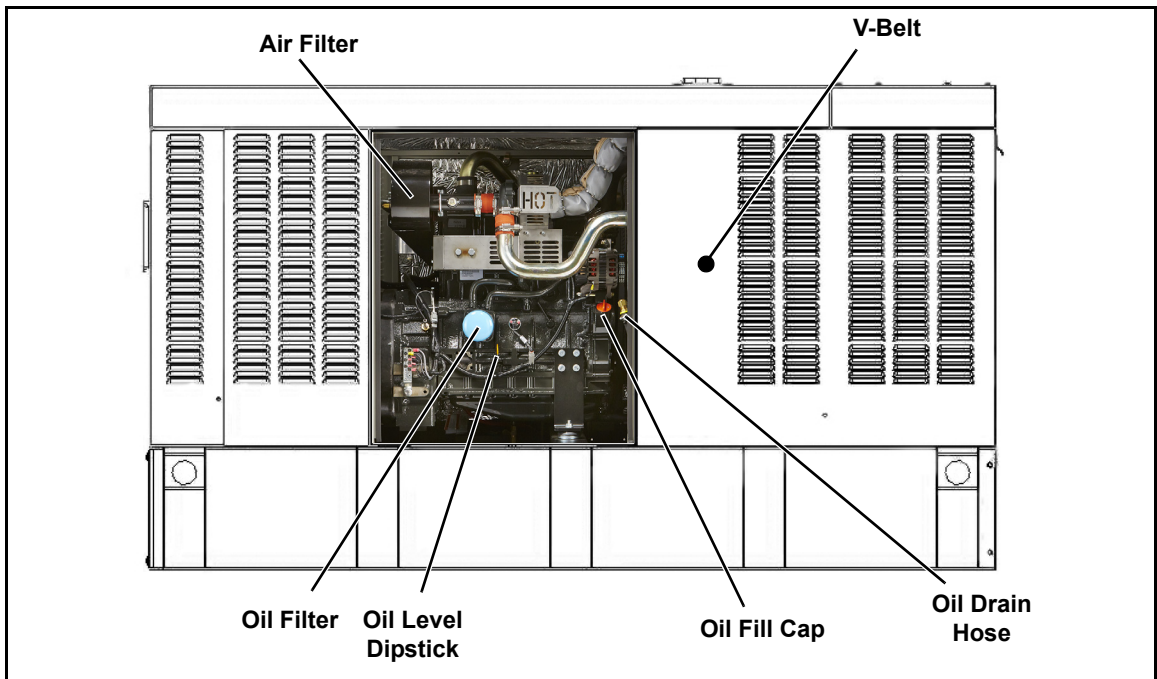

Figure 5-2. Right Side View

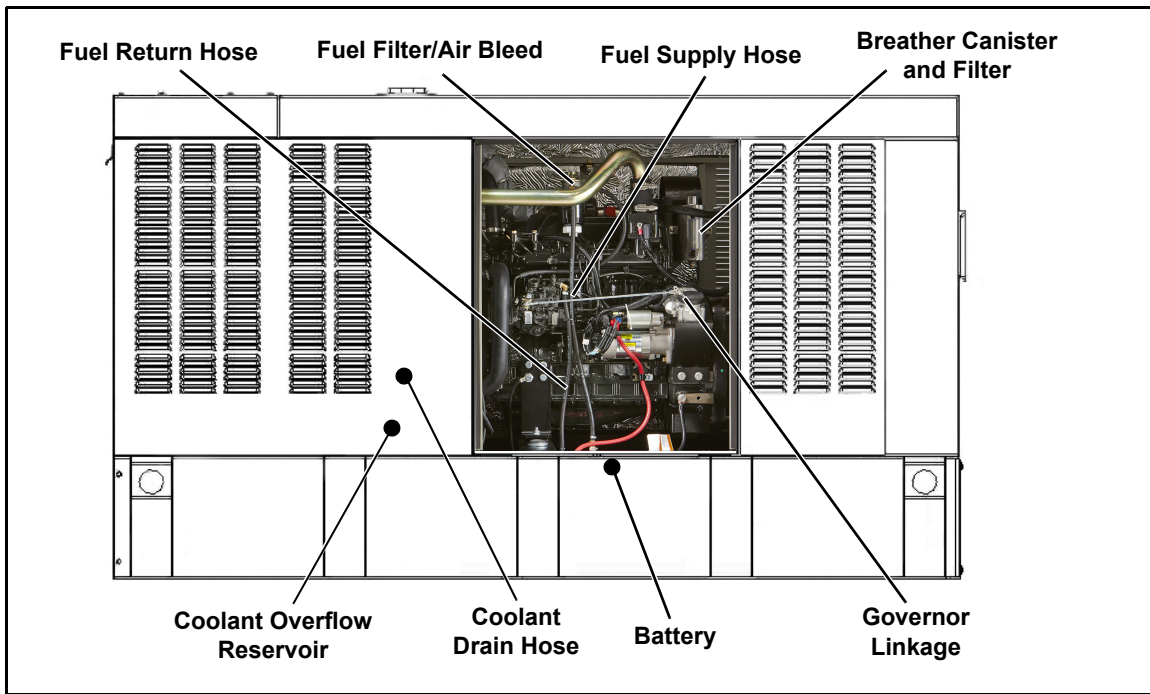

Figure 5-3. Left Side View

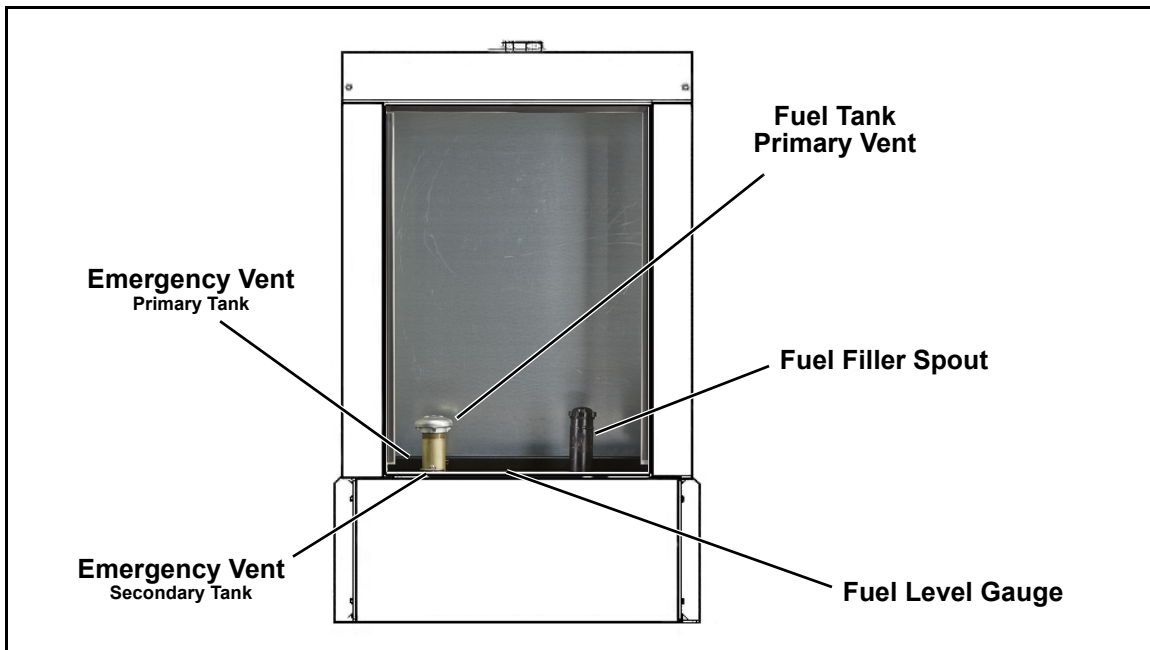

Figure 5-4. Front View

NOTE: The 3.4L engine is depicted in the artwork used in this manual. The location and appearance of some components may vary between engine models.

5.2 — Access Panels

Access panels are located at both the front and sides of the enclosure.

5.2.1— Removal

1. Insert key into latch and rotate counterclockwise 1/2 turn. See Figure 5-5.
2. Raise panel using thumb latch.

5.2.2— Installation

1. Lower panel into position using thumb latch.
2. Insert key into latch and rotate clockwise 1/2 turn.

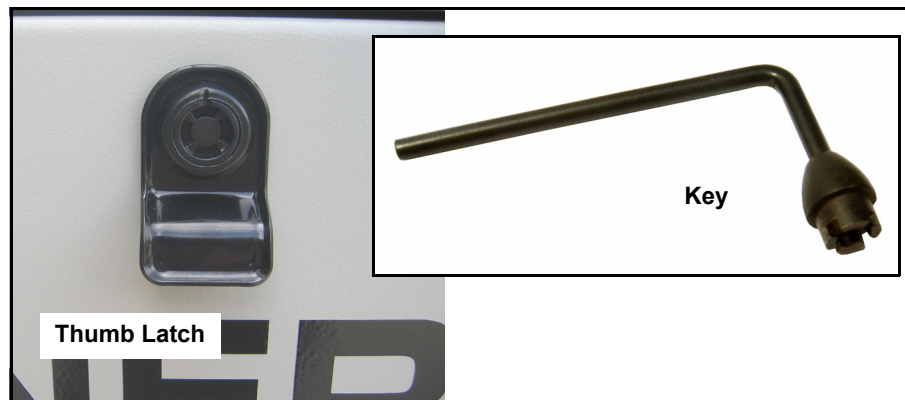

Figure 5-5. Access Panel Key

5.3 — Service Maintenance Intervals

NOTE: Use only Genuine Generac parts to ensure warranty coverage.

⚠ CAUTION!

 **All generator service must be performed by a qualified service person only.**

It is important to perform all maintenance at the interval specified in the Service Maintenance Schedule. This ensures safe and proper operation, as well as compliance with applicable emissions standards. Critical emissions maintenance must be performed for the Emissions Warranty to remain valid. Service and repairs may be performed by any qualified service technician or repair shop.

Observe the maintenance tasks and intervals shown in the table below.

Service	30 Hours Engine Break In	Daily If Running Continuously	Schedule A Every Year or 125 Hours	Schedule B Every 2 Years or 250 Hours	Schedule C Every 1000 Hours
Check Fuel Level and Fill		○	○	○	○
Drain Fuel Filter		○	○	○	○
Check Fuel Lines and Hoses		○	○	○	○
Check Coolant Level		○	○	○	○
Check Coolant Hoses		○	○	○	○
Check Radiator for Clogging		○	○	○	○
Check Lubricating Oil Level		○	○	○	○
Check Battery Condition/Fluid Level			○	○	○
Check/Adjust V-Belt Tension			○	○	○
Replace Air Filter Element			○	○	○
Drain Breather Canister and Replace Filter			○	○	○
Lubricate Governor Rod Linkage			○	○	○
Replace Lubricating Oil and Oil Filter	○			○	○
Replace Fuel Filter Element				○	○
Drain/Flush Coolant System				○	○
Inspect Fuel Tank					○
Check/Adjust Fuel Injection Valve Pressure					○
Adjust Intake/Exhaust Valve Clearance					○
Check/Adjust Fuel Injection Pump Timing					○
Tighten Critical Fasteners					○

NOTE: If the unit reaches a Schedule A or Schedule B maintenance interval with 900 to 999 total hours, have an authorized service provider perform the Schedule C maintenance tasks as well (and reset the A-B-C/Year maintenance schedule counter).

5.4 — Remove From Service

To ensure safety, follow the steps below prior to inspection, maintenance or service.

IMPORTANT NOTE: If currently experiencing a utility outage, see Subsection 6.3 —Removal From Service During Utility Outages for special instructions.

1. Open the viewing window. See Subsection 3.5 —Open Viewing Window.
2. Move the Main Circuit Breaker switch down to the OFF (Open) position. See A of Figure 5-6.
3. Press OFF on the control pad. A red LED illuminates to confirm that the system is in the OFF mode. See B of Figure 5-6.
4. Remove T1 fuse from transfer switch.
5. Pull up rubber flap covering fuse holder and remove 7.5 amp fuse. See C of Figure 5-6.
6. Place a DO NOT OPERATE tag or placard on both the control panel and transfer switch.
7. If the unit has been running, wait five minutes for the engine to cool.

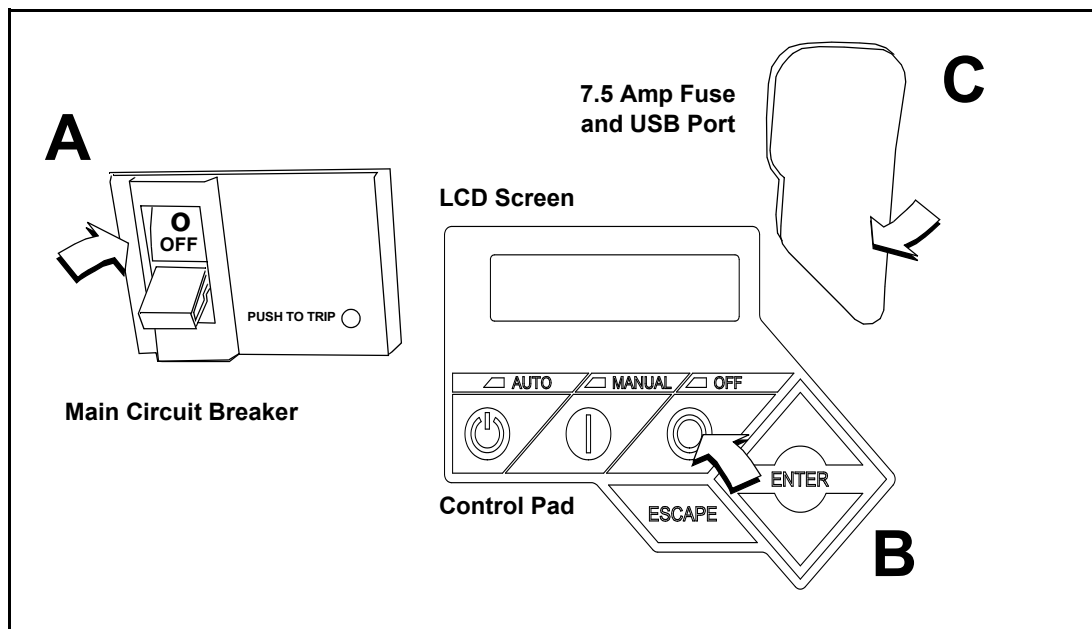

Figure 5-6. Generator Control Panel

5.5 — 30 Hour Break-In

Perform the following task:

- Replace Lubricating Oil and Oil Filter

NOTE: See Subsection 5.8.1 under Schedule B Maintenance.

5.6 — Daily Maintenance (If Running Continuously)

Perform the following tasks:

- Check Fuel Level and Fill
- Check Coolant Hoses
- Drain Fuel Filter
- Check Radiator for Clogging
- Check Fuel Lines and Hoses
- Check Lubricating Oil Level
- Check Coolant Level

NOTE: See Subsection 5.7.1 through Subsection 5.7.6 under Schedule A Maintenance.

5.7 — Schedule A Maintenance

NOTE: Perform Schedule A maintenance once each year or after 125 hours of service, whichever comes first.

5.7.1— Preliminary Instructions

1. See Subsection 5.4 —Remove From Service.
2. Remove access panels at the front and both sides of the enclosure. See Subsection 5.2 —Access Panels.
3. Remove battery negative cable (black) from battery negative (-) terminal.

NOTE: For general location of components, see Subsection 5.1 —Component Locations.

5.7.2— Check Fuel Level and Fill

1. Observe fuel gauge to note level of fuel in tank. See Figure 5-7.
2. Remove fuel fill cap from filler pipe.
3. Add fuel until needle on fuel gauge approaches the F(ull) mark.
4. Install fuel fill cap onto filler pipe.



Figure 5-7. Check Fuel Level Gauge and Fill

5.7.3— Drain Fuel Filter and Check Fuel Lines/Hoses

1. Slowly loosen water drain plug. See Figure 5-8.
2. Place a shop rag under the drain to catch any loss of water/fuel.
3. Work priming pump until water is drained and replaced by solid fuel. Tighten the water drain plug.
4. Check fuel filter and fuel lines/hoses for leaks. Tighten filter, fittings and hose clamps, if necessary.
5. Check hoses for nicks, cuts, tears or general deterioration. Replace as necessary.

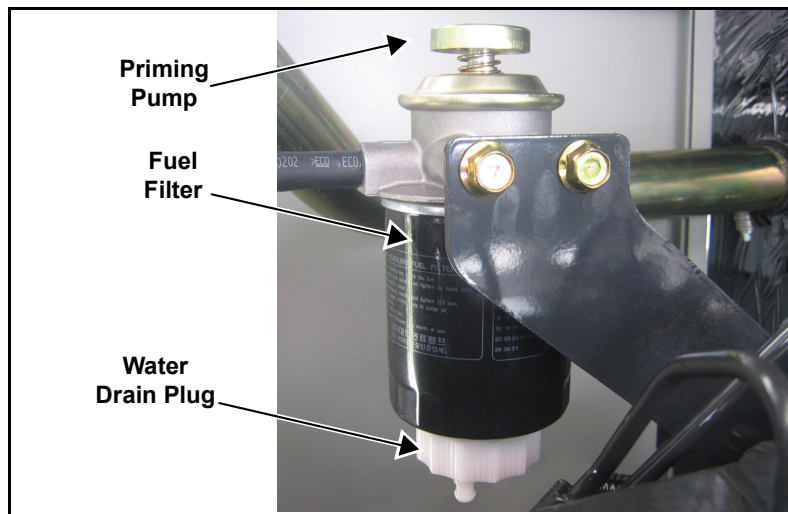

Figure 5-8. Drain Water From Fuel Filter

5.7.4— Check Coolant Level and Hoses

⚠ WARNING!



Do not add coolant when the engine is hot. Steam and scalding fluids can cause severe burns.

NOTE: On 2.3L models, remove ten screws to release louvered air discharge panel on left side of enclosure.

1. Verify that the coolant level is between the HOT and COLD marks on the overflow reservoir. See Figure 5-9.

NOTE: Coolant expands when hot, so the level may be higher than the HOT mark. Do not add coolant higher than the HOT mark.

2. If the coolant level is below the COLD mark, remove fill cap from overflow reservoir and add coolant. See Sub-section 2.4 —Coolant Water Treatment.
3. Check coolant hoses for leaks. Tighten hose clamps, if necessary.
4. Check hoses for nicks, cuts, tears or general deterioration. Replace as necessary.

NOTE: On 2.3L models, install louvered air discharge panel. Alternately tighten ten screws to 90 in-lbs using a crosswise pattern.

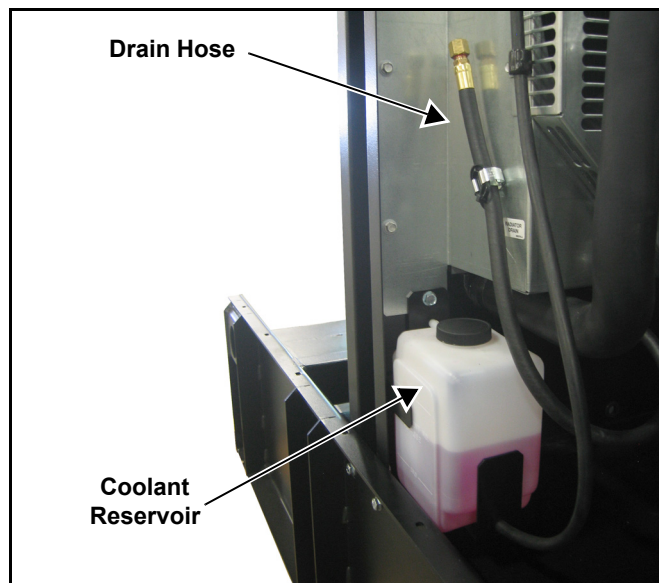

Figure 5-9. Coolant Overflow Reservoir and Drain Hose

5.7.5— Check Radiator for Clogging

Direct beam of flashlight through openings in fan guard to inspect the radiator fins. Carefully look for debris, accumulations of dirt or other deposits. If necessary, clean as follows:

1. On right side of enclosure, loosen two clamps at each end of turbocharger exhaust outlet pipe. Remove pipe, clamps and rubber couplings from engine.
2. Remove oil drain hose from holding clamp.
3. Remove four screws with nylon washers to release fan guard from radiator shroud.
4. On left side of enclosure, loosen two clamps at each end of air intake pipe. Remove pipe, clamps and rubber couplings from engine.
5. Remove coolant hoses from holding clamps.
6. Remove four screws with nylon washers to release fan guard from radiator shroud.
7. Carefully remove any debris from radiator fins. Use warm soapy water and a soft bristled brush to remove dirt and other deposits, if necessary.
8. On left side of enclosure, install four screws with nylon washers to fasten fan guard to radiator shroud.
9. Install coolant hoses into holding clamps.
10. Install clamps and rubber couplings onto each end of air intake pipe. Install pipe to air heater and radiator shroud. Tighten clamps.
11. On right side of enclosure, install four screws with nylon washers to fasten fan guard to radiator shroud.
12. Install oil drain hose into holding clamp.
13. Install clamps and rubber couplings onto each end of turbocharger exhaust outlet pipe. Install pipe to turbocharger outlet and radiator shroud. Tighten clamps.

5.7.6— Check Lubricating Oil Level

1. Remove dipstick and wipe with a clean cloth. See A of Figure 5-10.
2. Completely insert the dipstick and then remove it.
3. Verify that the oil level is at or near the H(igh) mark.

NOTE: Each hash mark or line below the H(igh) mark represents one liter. Add oil whenever the level is one liter or more below the H(igh) mark.

4. If necessary, remove the oil fill cap and slowly add oil until the level is at the H(igh) mark. See B of Figure 5-10. **DO NOT OVERFILL.**
5. Install dipstick and oil fill cap.
6. Check oil drain hose for leaks. Check hose for nicks, cuts, tears or general deterioration. Replace as necessary.

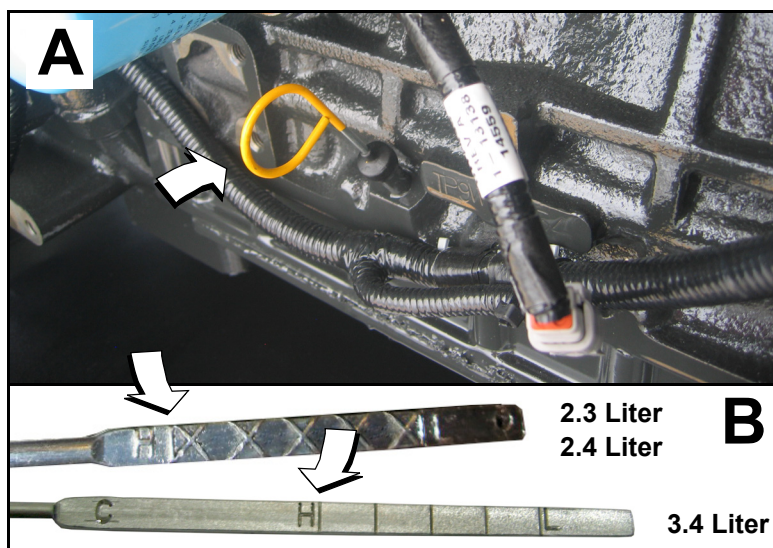

Figure 5-10. Oil Level Dipstick

5.7.7— Check Battery Condition/Fluid Level

5.7.7.1— Check Condition and Clean

NOTE: On 2.3L models, remove ten screws to release louvered air intake panel on left side of enclosure.

1. Verify that top of battery is clean and dry. Dirt and electrolyte on top of the battery can cause battery to self-discharge. Clean battery top with a solution of baking soda (sodium bicarbonate) and water (5 teaspoons baking soda per quart or liter of water). When solution stops bubbling, rinse off the battery with clean water.
2. Clean cable clamps and battery terminals using a wire brush or sandpaper to remove any oxidation.
3. Inspect battery screws, clamps and cables for breakage, loose connections and corrosion. Tighten and clean as necessary.
4. Check the battery posts for melting or damage caused by over tightening.
5. Inspect battery for discoloration, raised top or a warped or distorted case, which might indicate that the battery has been frozen, overheated or overcharged.
6. Inspect the battery case for cracks or leaks.
7. Check the battery fluid level of unsealed batteries. See Subsection 5.7.7.2—Check Fluid Level.
8. Check the battery state of charge. See Subsection 5.7.7.3—Check State of Charge.
9. Replace battery if necessary. See Subsection 5.7.7.4—Battery Replacement.

NOTE: On 2.3L models, start ten screws to install louvered air intake panel. Alternately tighten screws to 90 in-lbs (10 N-m) using a crosswise pattern.

5.7.7.2— Check Fluid Level

Check the fluid level of unsealed batteries. If necessary, fill with distilled water only. DO NOT use tap water.

5.7.7.3— Check State of Charge

Check the state of charge using a Digital Multimeter. Recharge and retest if state of charge is below manufacturer's recommendations. Replace battery if necessary.

5.7.7.4— Battery Replacement

Removal

⚠ CAUTION!



Always disconnect the negative battery cable first. If the positive cable should contact ground with the negative cable installed, the resulting sparks may cause a battery explosion which could result in serious injury.

1. Remove battery negative cable (black) from battery negative (-) terminal.
2. Remove battery positive cable (red) from battery positive (+) terminal.
3. Install rubber protective cover over battery positive (+) terminal.
4. Loosen two screws with nylon washers to release battery hold-down clamp from battery tray.
5. Grasp battery strap next to battery positive (+) terminal, and lift battery.
6. When battery tilts sideways, remove from opening.
7. Remove rubber protective cover from battery positive (+) terminal.

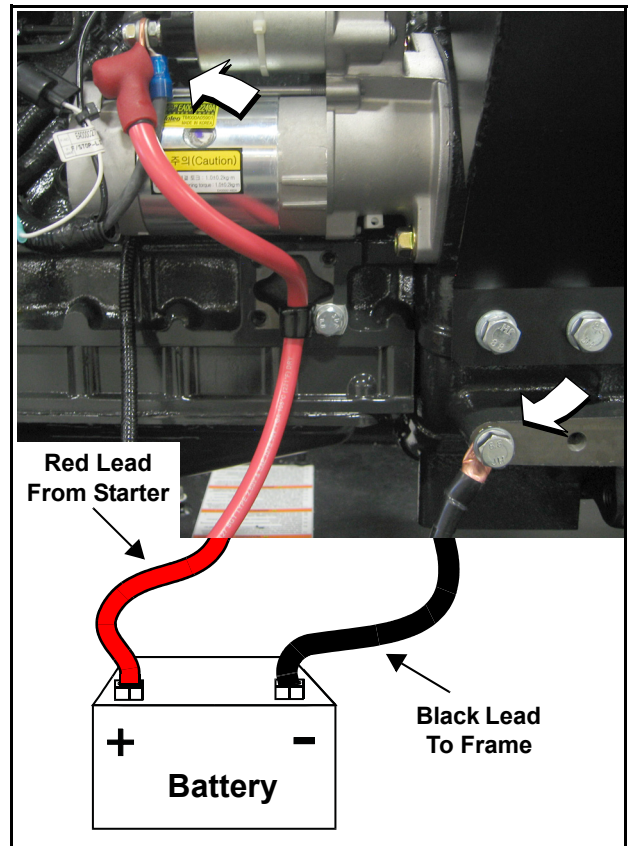

Figure 5-11. Battery Cable Connections

Installation

⚠ CAUTION!

Always connect the positive battery cable first. If the positive cable should contact ground with the negative cable installed, the resulting sparks may cause a battery explosion which could result in serious injury.

1. Install rubber protective cover over battery positive (+) terminal. See A of Figure 5-12.
2. Grasp battery strap next to battery positive (+) terminal, and lift battery.
3. When battery tilts sideways, insert into opening. See B of Figure 5-12.
4. Return battery to the horizontal position while sliding it onto battery tray.
5. Tighten two screws with nylon washers to secure hold-down clamp to battery tray.
6. Remove rubber protective cover from battery positive (+) terminal.
7. Install battery positive cable (red) to battery positive (+) terminal.
8. Install battery negative cable (black) to battery negative (-) terminal.

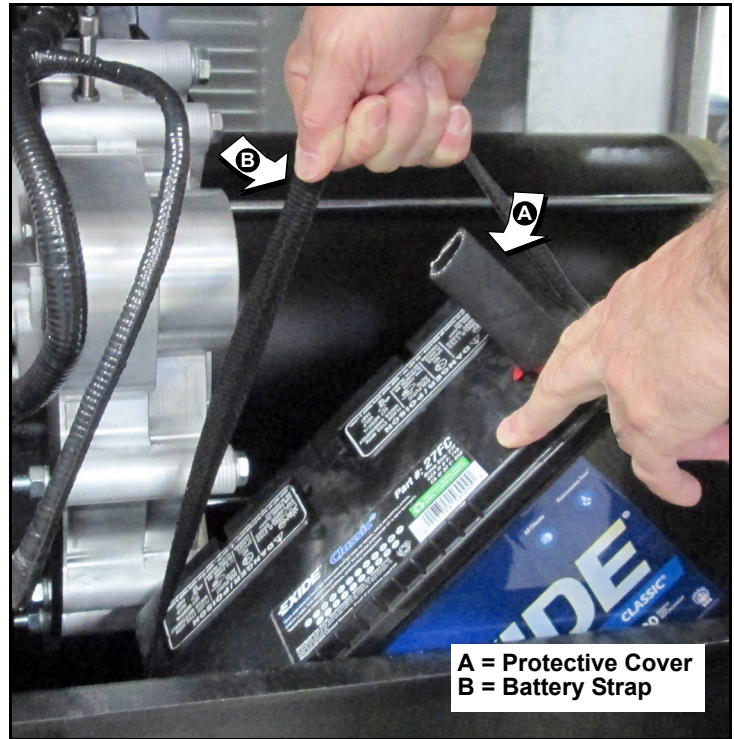

Figure 5-12. Install Battery (2.3L Models)

5.7.8— Check and Adjust V-Belt

5.7.8.1— Check

Check the V-belt deflection. Too little belt deflection accelerates belt wear, while too much deflection leaves the pulley idle, overheats the engine, and no-load is generated. Adjust the belt deflection as follows:

1. On right side of enclosure, loosen two clamps at each end of turbocharger exhaust outlet pipe. Remove pipe, clamps and rubber couplings from engine.
2. Remove oil drain hose from holding clamp.
3. Remove four screws with nylon washers to release fan guard from radiator shroud.
4. Perform visual inspection as follows:
 - Inspect belt for cracks, fraying, excessive wear or other damage.
 - Verify that belt is free of grease and oil. Replace belt if contaminated.

NOTE: Use a solution of soap and warm water to clean pulleys, if necessary. Avoid use of solvents, but if used, always follow by a soap and water wash.

5. Using a suitable gauge, apply 22 lbs (10 kgf) force midway between the crankshaft and alternator pulleys. See Figure 5-13.
6. Take note of gauge reading. If belt deflection is not within specification, see Subsection 5.7.8.2—Adjust.

Belt Condition	Deflection
New	8-12 mm
Used	10-15 mm

7. Install four screws with nylon washers to fasten fan guard to radiator shroud.
8. Install oil drain hose into holding clamp.
9. Install clamps and rubber couplings onto each end of turbocharger exhaust outlet pipe. Install pipe to turbocharger outlet and radiator shroud. Tighten clamps.

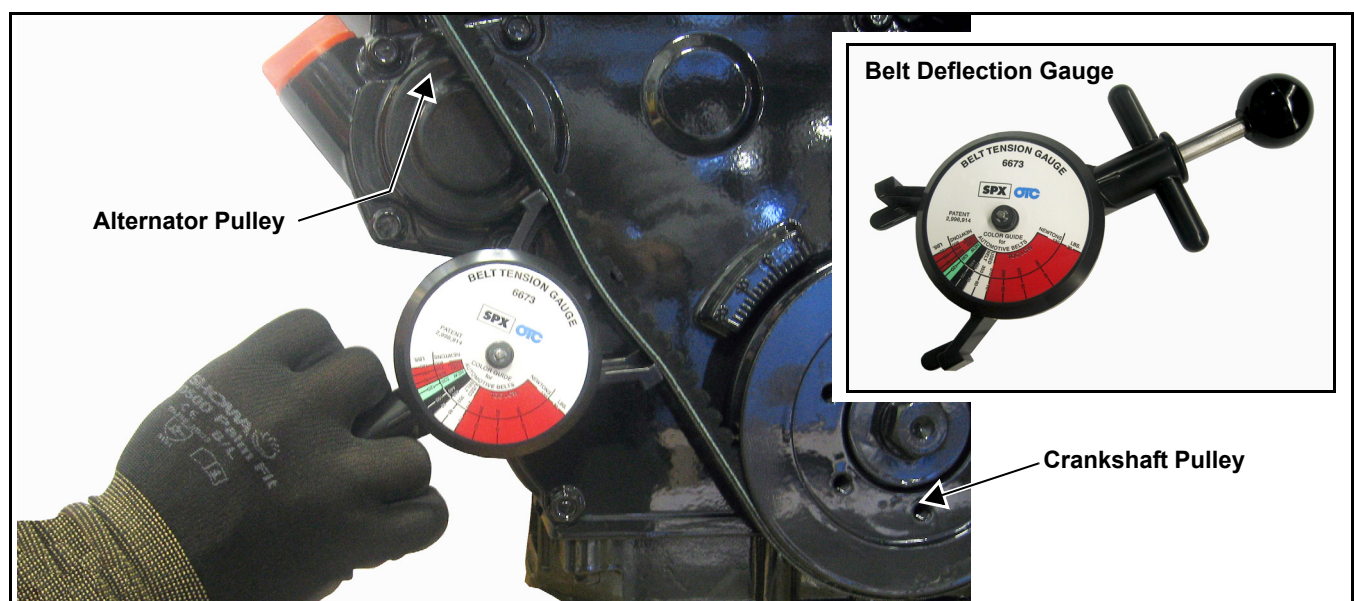

Figure 5-13. Check V-Belt Deflection

5.7.8.2— Adjust

1. Loosen tension adjuster screw (top). Loosen hex nut on pivot screw (bottom). Rotate alternator outward to reduce belt deflection, rotate inward to increase belt deflection.
2. Tighten tension adjuster screw (top) to 17-22 ft-lbs (23-30 N-m). Tighten hex nut on pivot screw (bottom) to 33-43 ft-lbs (45-58 N-m).
3. Recheck belt deflection and repeat steps as necessary.

5.7.9— Replace Air Filter Element

1. Remove wing nut from threaded rod to release air cleaner cover. See Figure 5-14.
2. Remove the air filter element and discard.
3. Thoroughly clean air cleaner cover of any dust, dirt, or debris.
4. Place **new** air filter element against adapter flange.

NOTE: The air filter element is not directional.

5. Install air cleaner cover over threaded rod. Install wing nut and tighten until snug.

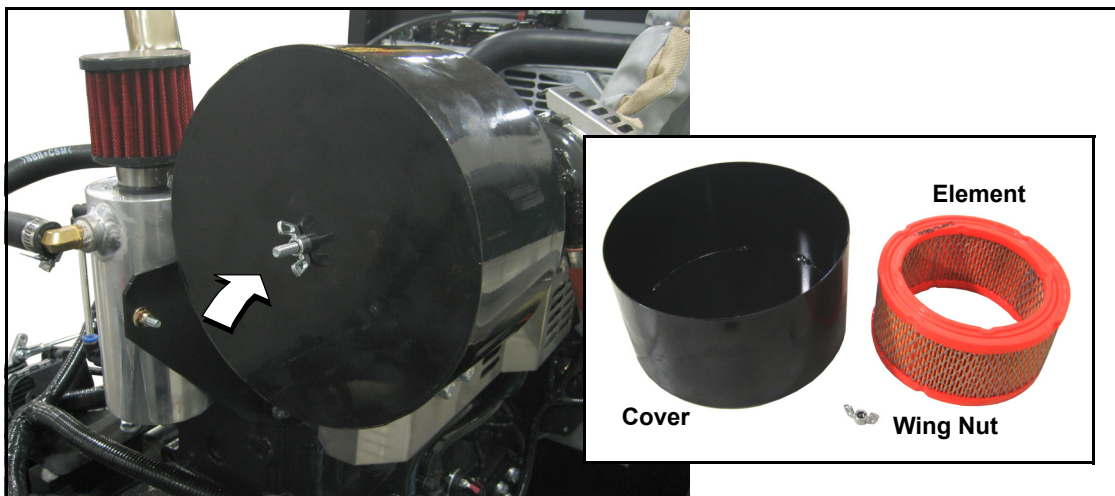

Figure 5-14. Air Cleaner Cover and Filter Element

5.7.10— Drain Breather Canister and Replace Filter

NOTE: This procedure only applies to turbocharged engines (2.4L/3.4L models).

1. Observe sight glass for level of oil in canister. See Figure 5-15.
2. When oil level approaches top of sight glass, remove plug at bottom of canister to drain oil.
3. Install drain plug at bottom of canister and tighten until snug.
4. Loosen clamp and remove filter element.
5. Install **new** filter element onto canister and tighten clamp.
6. Inspect hoses for nicks, cuts, tears or signs of deterioration. Replace as necessary.
7. Check for leakage. Tighten clamps if leaks are found.

NOTE: Dispose of used fuel filter at a proper collection center.

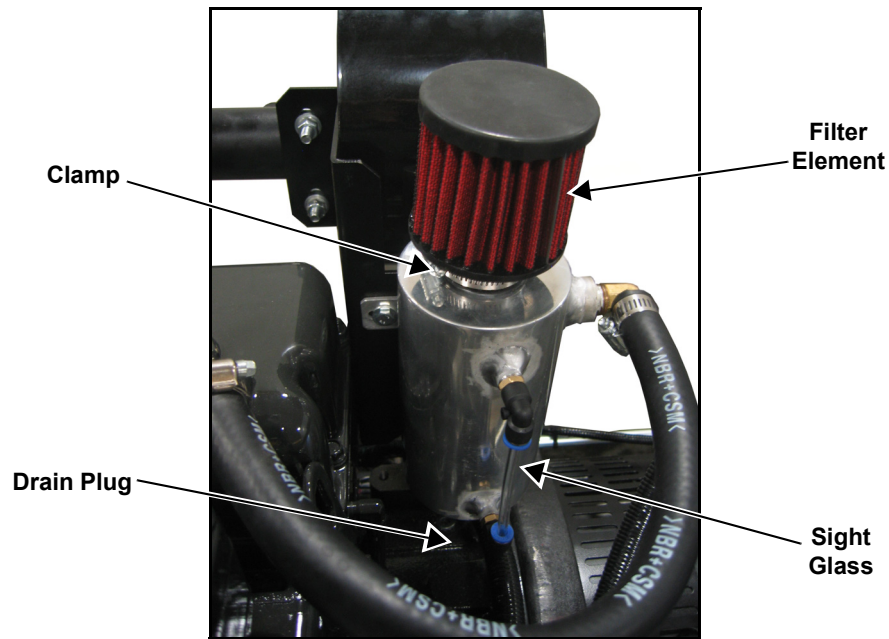

Figure 5-15. Drain Breather Canister and Replace Filter

5.7.11— Lubricate Governor Rod Linkage

1. Lubricate both ends of rod with a silicone spray. See Figure 5-16.
2. Verify that rod moves freely without binding.

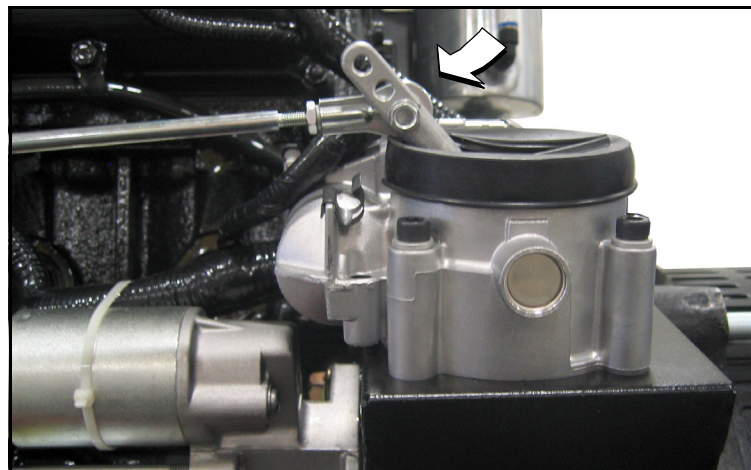

Figure 5-16. Lubricate Governor Rod Ends

5.7.12— Final Instructions

1. Install battery negative cable (black) onto battery negative (-) terminal.
2. Install access panels at the front and both sides of the enclosure. See Subsection 5.2 —Access Panels.
3. See Subsection 5.10 —Return To Service.

5.8 — Schedule B Maintenance

NOTE: Perform Schedule B maintenance every two years or after 250 hours of service, whichever comes first. Before proceeding below, first perform all tasks listed under Schedule A Maintenance.

NOTE: For general location of components, see Subsection 5.1 —Component Locations.

5.8.1— Replace Lubricating Oil and Oil Filter

1. Remove oil drain hose from holding clamp. See Figure 5-17.
2. Use one wrench to hold hex on hose fitting (to prevent rotation), and use second wrench to remove drain plug.
3. Drain oil into a suitable container.
4. Install drain plug onto end of oil drain hose.
5. Install oil drain hose into holding clamp.
6. Rotate oil filter counterclockwise to remove from oil filter adapter.
7. Apply a light coat of clean engine oil to gasket of **new** oil filter.
8. Install oil filter by hand until gasket just contacts oil filter adapter. Tighten oil filter an additional 3/4 to one full turn.
9. Remove fill cap and fill engine with the recommended oil. See Subsection 2.3 —Engine Oil Recommendations.
10. Install fill cap.
11. Install battery negative cable (black) onto battery negative (-) terminal.
12. Pull up rubber flap covering fuse holder and install 7.5 amp fuse.
13. Press MANUAL on the control pad to start the engine.
14. Allow the engine to run for one minute. Check for leaks while the engine is running.
15. Press OFF on the control pad. A red LED illuminates to confirm that the system is in the OFF mode.
16. Wait a few minutes for the engine to cool and to allow oil to drain back to the oil pan.
17. Check oil level and add oil as necessary. **DO NOT OVERFILL.**
18. Install fill cap.

NOTE: Dispose of used oil and oil filter at a proper collection center.

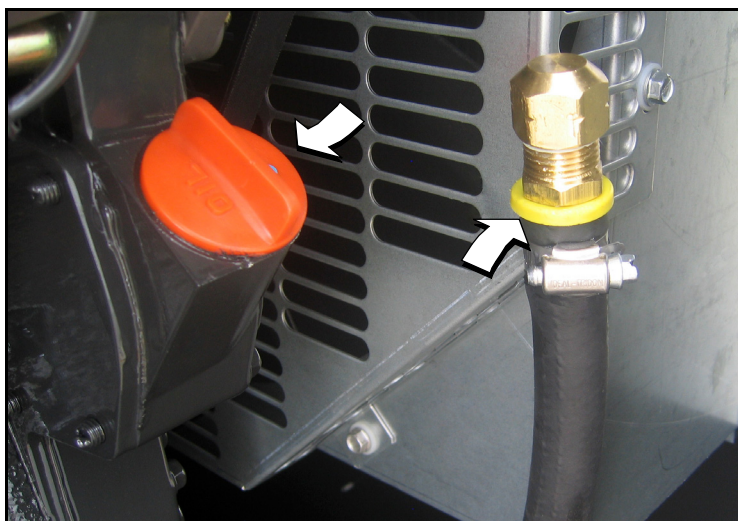

Figure 5-17. Oil Fill Cap and Drain Hose

5.8.2— Replace Fuel Filter

1. Slowly loosen water drain plug. See Figure 5-18.
2. Rotate filter counterclockwise to remove from filter adapter.
3. Install **new** filter by hand until gasket just contacts filter adapter. Tighten filter an additional 3/4 to one full turn.
4. Tighten water drain plug.

NOTE: Dispose of used fuel filter at a proper collection center.

5. See Subsection 5.8.2.1—Prime Fuel System.

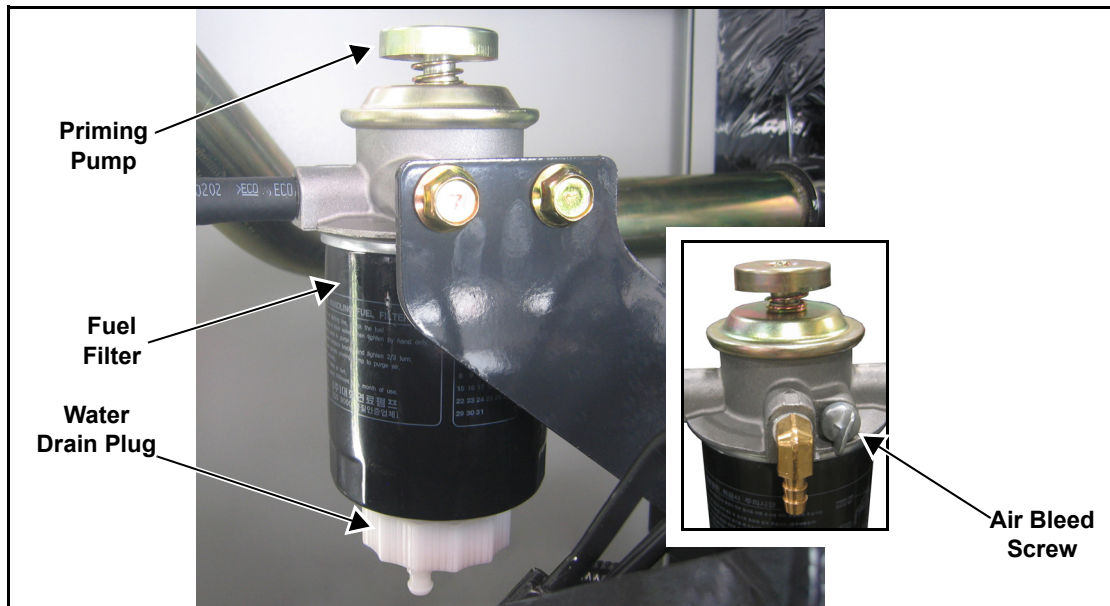

Figure 5-18. Prime Fuel System

5.8.2.1— Prime Fuel System

1. Place a shop rag near the air bleed screw to catch any loss of fuel.
2. Loosen the air bleed screw and work priming pump until bubbles are observed.
3. When all bubbles are purged and replaced by a solid stream of fuel, depress pump handle and tighten the air bleed screw.
4. Check for leaks.

5.8.3— Drain/Flush Coolant System

NOTE: On 2.3L models, remove ten screws to release louvered air discharge panel on left side of enclosure.

1. Disconnect and empty coolant overflow reservoir.
2. Install and connect coolant overflow reservoir.

⚠ WARNING!



Verify that the engine is cool before removing the radiator cap. The cooling system is under pressure, so steam and hot liquid can come out forcefully when the cap is loosened.

3. Slowly unscrew radiator cap.
4. Locate drain cock at bottom left side of radiator. Rotate hex fitting to open drain cock. See A of Figure 5-19.

5. Remove coolant drain hose from holding clamp.
6. Use wrench to hold hex on hose fitting (to prevent rotation), and use second wrench to remove drain plug.
7. Drain coolant into a suitable container.
8. Install plug at end of drain hose.
9. Install drain hose in holding clamp.
10. Rotate hex fitting to close radiator drain cock.
11. Obtain at least 2.8 gallons (10.6 liters) of coolant. See Subsection 2.4 —Coolant Water Treatment.
12. Rotate and remove plastic cover at top of enclosure and insert funnel into filler neck. See B of Figure 5-19.
13. Slowly pour coolant into filler neck until radiator is full.
14. Install radiator cap.
15. Press MANUAL on the control pad to start the engine. A blue LED illuminates to confirm that the system is in the MANUAL mode.
16. Allow engine to run until the thermostat opens, as indicated by heating of the top radiator hose.
17. Check coolant hoses for leaks. Tighten clamps, if necessary.
18. Press OFF on the control pad to shut the engine down.
19. Wait five minutes for the engine to cool.
20. Repeat steps 4-20 to drain and refill cooling system.
21. Install plastic cover at top of enclosure and rotate until tight.
22. Check hoses for nicks, cuts, tears or general deterioration. Replace as necessary.

NOTE: On 2.3L models, start ten screws to install louvered air discharge panel. Alternately tighten screws to 90 in-lbs using a crosswise pattern.

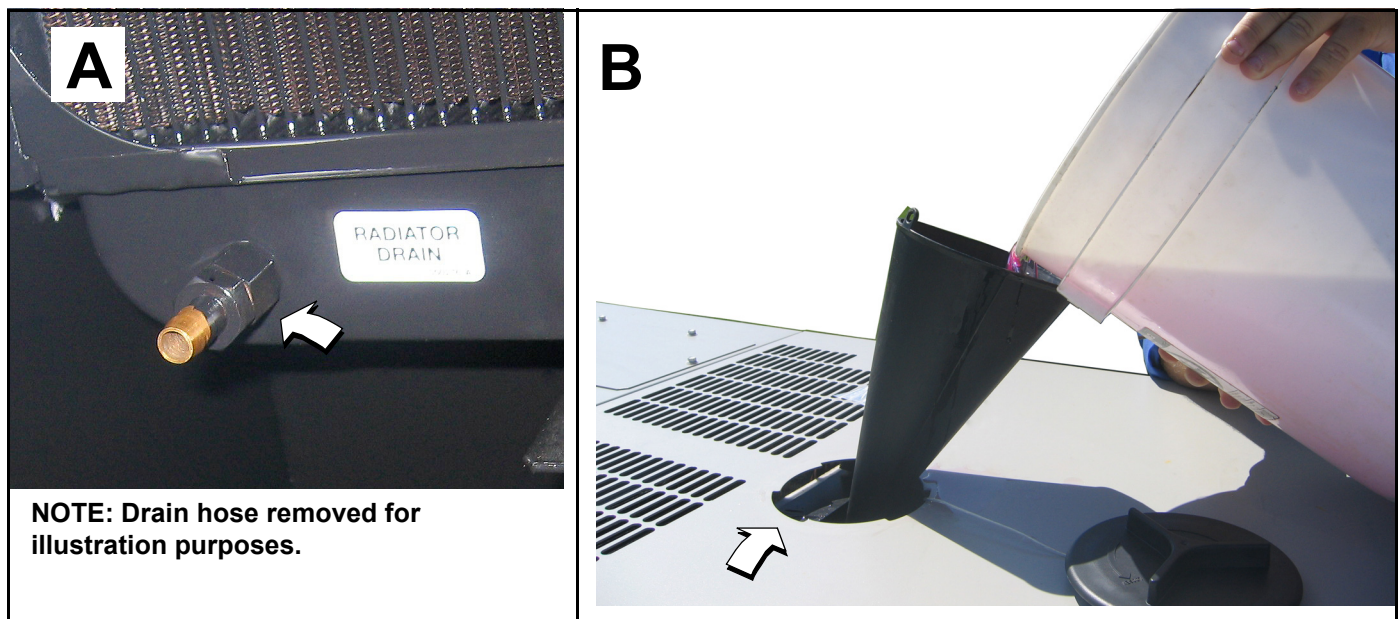

Figure 5-19. Drain/Fill Coolant System

5.8.4— Final Instructions

1. Install left and right side access panels. See Subsection 5.2 —Access Panels.
2. See Subsection 5.10 —Return To Service.

5.9 — Schedule C Maintenance

NOTE: Perform Schedule C maintenance after 1000 hours of service. Before proceeding below, first perform all tasks listed under Schedule A Maintenance and Schedule B Maintenance.

⚠ CAUTION!



The following procedures require special tools and skills. Contact a Generac Dealer or an authorized service provider to perform these tasks.

- Inspect Fuel Tank
- Check/Adjust Fuel Injection Valve Pressure
- Check/Adjust Fuel Injection Pump Timing
- Adjust Intake/Exhaust Valve Clearance
- Tighten Critical Fasteners

NOTE: Reset the A-B-C/Year time maintenance schedule counter using the Dealer Sub Menu (password required).

5.10 — Return To Service

After inspection, maintenance or service of the generator, return the unit to service following the steps below.

1. Pull up rubber flap covering fuse holder and install 7.5 amp fuse. See A of Figure 5-20.
2. Install T1 fuse in transfer switch.
3. Press AUTO on the control pad. A green LED illuminates to confirm that the system is in the AUTO mode. See B of Figure 5-20.
4. Move the Main Circuit Breaker switch up to the ON (Closed) position. See C of Figure 5-20.
5. Close the viewing window.
6. Remove the DO NOT OPERATE tag or placard from both the control panel and transfer switch.
7. Reset the time and date.

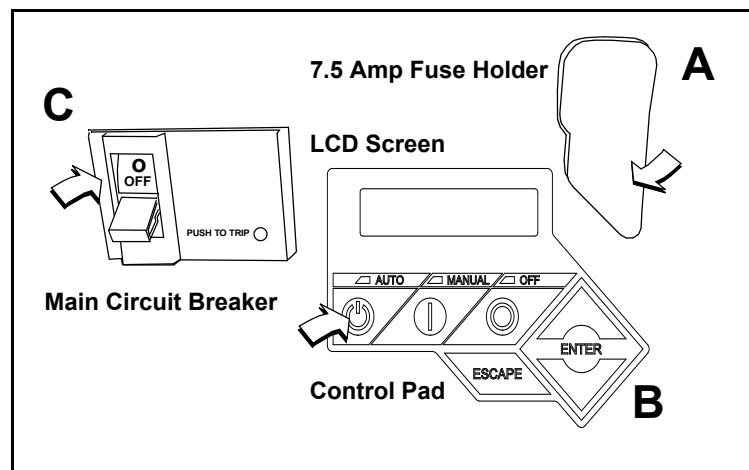

Figure 5-20. Generator Control Panel

This page intentionally left blank.

Section 6 *Troubleshooting*

6.1 — Engine Troubleshooting

Problem	Cause	Correction
The engine will not crank.	Fuse blown.	Replace 7.5 amp fuse in generator control panel. Correct short circuit condition if fuse blows again.
	Loose, corroded or defective battery cables.	Tighten, clean or replace as necessary.*
	Defective starter contact.	Tighten, clean or replace as necessary.*
	Defective starter motor.	Tighten, clean or replace as necessary.*
	Dead Battery.	Charge or replace battery.
The engine cranks but will not start.	Out of fuel.	Replenish fuel. Turn on fuel valve.
	Defective fuel solenoid.	*
	Open F1 5 amp fuse.	Replace F1 5 amp fuse if fuse blows again.*
	Defective fuel system.	*
	No fuel to pump.	Prime fuel system.*
The engine starts hard and runs rough.	Air cleaner plugged or damaged.	Check/replace air cleaner.
The generator is set to OFF, but the engine continues to run.	Defective keypad.	*
	Defective control board.	*
There is no AC output from the generator.	Main line circuit breaker is in the OFF (OPEN) position.	Reset circuit breaker to ON (CLOSED) position.
	Generator internal failure.	*
There is no transfer to standby after utility source failure.	Defective transfer switch coil.	*
	Defective transfer relay.	*
	Transfer relay circuit open.	*
	Defective control logic board.	*
Unit consumes large amounts of oil.	Engine over filled with oil.	Adjust oil to correct level.
	Engine breather defective.	*
	Incorrect oil type or viscosity.	See Engine Oil Recommendations.
	Damaged gasket, seal or hose.	Check for oil leaks.
* Contact an Authorized Service Dealer for assistance.		

6.2 — Controller Troubleshooting

Active Alarm	Problem	Solution
NOT ACTIVATED	Unit will not start in AUTO with utility loss.	Refer to activation section in Owner's Manual.
NONE	Unit running in AUTO but no power in house.	Check MLCB. Contact servicing dealer if MLCB is in the ON position.
NONE	Unit will not start in AUTO with utility loss.	Check screen for start delay countdown. If the start up delay is greater than expected, contact servicing dealer to adjust from 2 to 1500 seconds.
HIGH TEMPERATURE	Unit shuts down during operation.	Check ventilation around the intake, exhaust and rear of generator. Contact servicing dealer if no obstruction is found.
OVERLOAD	Unit shuts down during operation.	Clear alarm and remove household loads from the generator. Put back in AUTO and restart.
RPM SENSE LOSS	Unit was running and shuts down, attempts to restart.	Clear alarm and remove household loads from the generator. Put back in AUTO and restart. If problem returns, contact servicing dealer to investigate possible fuel issue.
LOW OIL PRESSURE	Unit will not start in AUTO with utility loss.	Check oil level. Add oil per Owner's Manual. Contact servicing dealer if oil level is correct.
RPM SENSE LOSS	Unit will not start in AUTO with utility loss.	Clear alarm. From the MAIN menu on the control panel, navigate to the BATTERY MENU. Contact servicing dealer if battery is GOOD. Replace battery If CHECK BATTERY is displayed.
OVERCRANK	Unit will not start in AUTO with utility loss.	Clear alarm. Attempt to start the unit in MANUAL. If it does not start or starts and runs rough, contact servicing dealer.
FUSE PROBLEM	Unit will not start in AUTO with utility loss.	Check ATO 7.5 amp fuse. Replace with same type fuse if bad. Contact servicing dealer if fuse is good.
OVERSPEED	Unit will not start in AUTO with utility loss.	Contact servicing dealer.
UNDER VOLTAGE	Unit will not start in AUTO with utility loss.	Contact servicing dealer.
UNDERSPEED	Unit will not start in AUTO with utility loss.	Contact servicing dealer.
MISWIRE	Unit will not start in AUTO with utility loss.	Contact servicing dealer.
OVERVOLTAGE	Unit will not start in AUTO with utility loss.	Contact servicing dealer.
LOW BATTERY	Warning active.	Clear alarm. From the MAIN menu on the control panel, navigate to the BATTERY MENU. Contact servicing dealer if battery is GOOD. Replace battery If CHECK BATTERY is displayed.
BATTERY PROBLEM	Warning active.	Contact servicing dealer.
CHARGER WARNING	Warning active.	Contact servicing dealer
SERVICE SCHEDULE A	Warning active.	Perform SERVICE SCHEDULE A maintenance; press ENTER to clear.
SERVICE SCHEDULE B	Warning active.	Perform SERVICE SCHEDULE B maintenance; press ENTER to clear.
SERVICE SCHEDULE C	Warning active.	Perform SERVICE SCHEDULE C maintenance; press ENTER to clear.

6.3 — Removal From Service During Utility Outages

If, during prolonged utility outages, the user wishes to remove the unit from service to conserve fuel, reduce run hours, or to perform maintenance tasks, then complete the steps listed below.

IMPORTANT NOTE: Failure to abide by this procedure can result in equipment damage.

To remove the generator from service while running in AUTO and online, proceed as follows:

1. Turn the main utility disconnect to OFF (Open).
2. Open the viewing window. See Subsection 3.5 —Open Viewing Window.
3. Move the Main Circuit Breaker switch down to the OFF (Open) position.
4. Press OFF on the control pad. A red LED illuminates to confirm that the system is in the OFF mode.

NOTE: If inspection and/or maintenance tasks are to be performed, complete the additional steps listed below.

5. Remove T1 fuse from transfer switch.
6. Pull up rubber flap covering fuse holder and remove 7.5 amp fuse.
7. Remove battery negative cable (black) from battery negative (-) terminal.
8. Place a DO NOT OPERATE tag or placard on both the control panel and transfer switch.

To return the generator to service, proceed as follows:

NOTE: If inspection and/or maintenance tasks were performed, start with step 1. If the unit was just shut down to conserve fuel or to reduce run hours, start at step 5.

1. Install battery negative cable (black) onto battery negative (-) terminal.
2. Pull up rubber flap covering fuse holder and install 7.5 amp fuse.
3. Install T1 fuse in transfer switch.
4. Remove the DO NOT OPERATE tag or placard from both the control panel and transfer switch.
5. Press AUTO on the control pad. A green LED illuminates to confirm that the system is in the AUTO mode. Allow the generator to start and run for a few minutes.
6. Move the Main Circuit Breaker switch up to the ON (Closed) position.
7. Turn the main utility disconnect to ON (Closed).
8. Close the viewing window.

6.4 — Storage

6.4.1— Prepare For Storage

If the generator cannot be exercised every **seven** days and will be out of service longer than 90 days, prepare for storage as follows:

1. Open the viewing window. See Subsection 3.5 —Open Viewing Window.
2. Press MANUAL on the control pad to start the engine. A blue LED illuminates to confirm that the system is in the MANUAL mode.
3. Allow the engine to run until it reaches normal operating temperature.
4. Press OFF on the control pad. A red LED illuminates to confirm that the system is in the OFF mode.
5. Move the Main Circuit Breaker switch on the control panel down to the OFF (Open) position.
6. Pull up rubber flap covering fuse holder and remove 7.5 amp fuse.
7. Turn off utility power to the transfer switch.
8. Place a DO NOT OPERATE tag or placard on both the control panel and transfer switch.
9. Wait five minutes for the engine to cool.

10. Remove right side access panel. See Subsection 5.2 —Access Panels.
11. Remove oil drain hose from holding clamp.
12. Use one wrench to hold hex on hose fitting (to prevent rotation), and use second wrench to remove drain plug.
13. Drain oil into a suitable container.
14. Install drain plug onto end of oil drain hose.
15. Install oil drain hose into holding clamp.
16. Rotate oil filter counterclockwise to remove from oil filter adapter.
17. Apply a light coat of clean engine oil to gasket of **new** oil filter.
18. Install oil filter by hand until gasket just contacts oil filter adapter. Tighten oil filter an additional 3/4 to one full turn.
19. Remove oil fill cap and fill engine with the recommended oil. See Subsection 2.3 —Engine Oil Recommendations.
20. Install oil fill cap.
21. Install right side access panel. See Subsection 5.2 —Access Panels.

NOTE: Dispose of used oil and oil filter at a proper collection center.

22. Remove left side access panel. See Subsection 5.2 —Access Panels.

NOTE: On 2.3L models, remove ten screws to release louvered air intake panel.

⚠ WARNING!



Always disconnect the negative battery cable first. If the positive cable should contact ground with the negative cable installed, the resulting sparks may cause a battery explosion which could result in serious injury.

23. Remove battery negative cable (black) from battery negative (-) terminal.
24. Remove battery positive cable (red) from battery positive (+) terminal.
25. Remove two screws to release battery hold-down clamp from platform.
26. Remove battery and store on a wooden board in a cool, dry room. Do not store the battery on a concrete or earthen floor.
27. Install left side access panel. See Subsection 5.2 —Access Panels.

NOTE: On 2.3L models, start ten screws to install louvered air intake panel. Alternately tighten screws to 90 in-lbs.

28. Thoroughly clean and wipe down the generator. See Subsection 2.7 —Corrosion Protection.

6.4.2— Return From Storage

To return the unit to service after storage, proceed as follows:

1. Thoroughly clean and wipe down the generator. See Subsection 2.7 —Corrosion Protection.
2. Remove left side access panel. See Subsection 5.2 —Access Panels.

NOTE: On 2.3L models, remove ten screws to release louvered air intake panel.

3. Install battery onto tray oriented with the negative (-) post toward the front of the enclosure.
4. Install two screws with nylon washers to secure battery hold-down clamp to tray.
5. Check battery. See Subsection 5.7.7—Check Battery Condition/Fluid Level..

⚠ WARNING!



Always connect the positive battery cable first. If the positive cable should contact ground with the negative cable installed, the resulting sparks may cause a battery explosion which could result in serious injury.

6. Install battery positive cable (red) onto battery positive (+) terminal.
7. Install battery negative cable (black) onto battery negative (-) terminal.

8. Install left side access panel. See Subsection 5.2 —Access Panels.

NOTE: On 2.3L models, start ten screws to install louvered air intake panel. Alternately tighten screws to 90 in-lbs.

9. Remove right side access panel. See Subsection 5.2 —Access Panels.
10. Check oil level and add oil as necessary. **DO NOT OVERFILL.**
11. Open the viewing window. See Subsection 3.5 —Open Viewing Window.
12. Pull up rubber flap covering fuse holder and install 7.5 amp fuse.
13. Move the Main Circuit Breaker switch up to the ON (Closed) position.
14. Press MANUAL on the control pad to start the engine. A blue LED illuminates to confirm that the system is in the MANUAL mode.
15. Allow the engine to run until it reaches normal operating temperature. Check for leaks while the engine is running.
16. Press OFF on the control pad. A red LED illuminates to confirm that the system is in the OFF mode.
17. Install right side access panel. See Subsection 5.2 —Access Panels.
18. Turn on utility power to the transfer switch.
19. Press AUTO on the control pad. A green LED illuminates to confirm that the system is in the AUTO mode.
20. Reset the time and date.
21. Close the viewing window.

6.5 — Attention After Submersion

Do NOT start and operate the generator if it has been submerged in water. Have a Dealer thoroughly clean, dry, and inspect the generator following any submersion. If the structure (home) has been flooded, it should be inspected by a certified electrician to ensure there won't be any electrical problems during generator operation or when utility power is returned.

6.6 — Attention After Fuel Spillage

Contact reputable local company that performs clean up and disposal services.

6.7 — Contaminated Fuel Disposal

Contact reputable local company that performs purging, burnishing and disposal services.

This page intentionally left blank.

NOTES

Part No. 0K3220 Rev. J 05/07/2015 Printed in USA
© Generac Power Systems, Inc. All rights reserved
Specifications are subject to change without notice.
No reproduction allowed in any form without prior written
consent from Generac Power Systems, Inc.

GENERAC[®]



Generac Power Systems, Inc.
S45 W29290 Hwy. 59
Waukesha, WI 53189
1-888-GENERAC (1-888-436-3722)
generac.com