

Genie®



Operator's Manual

Second Edition
Seventh Printing
Part No. 33499

Superlift™ Advantage

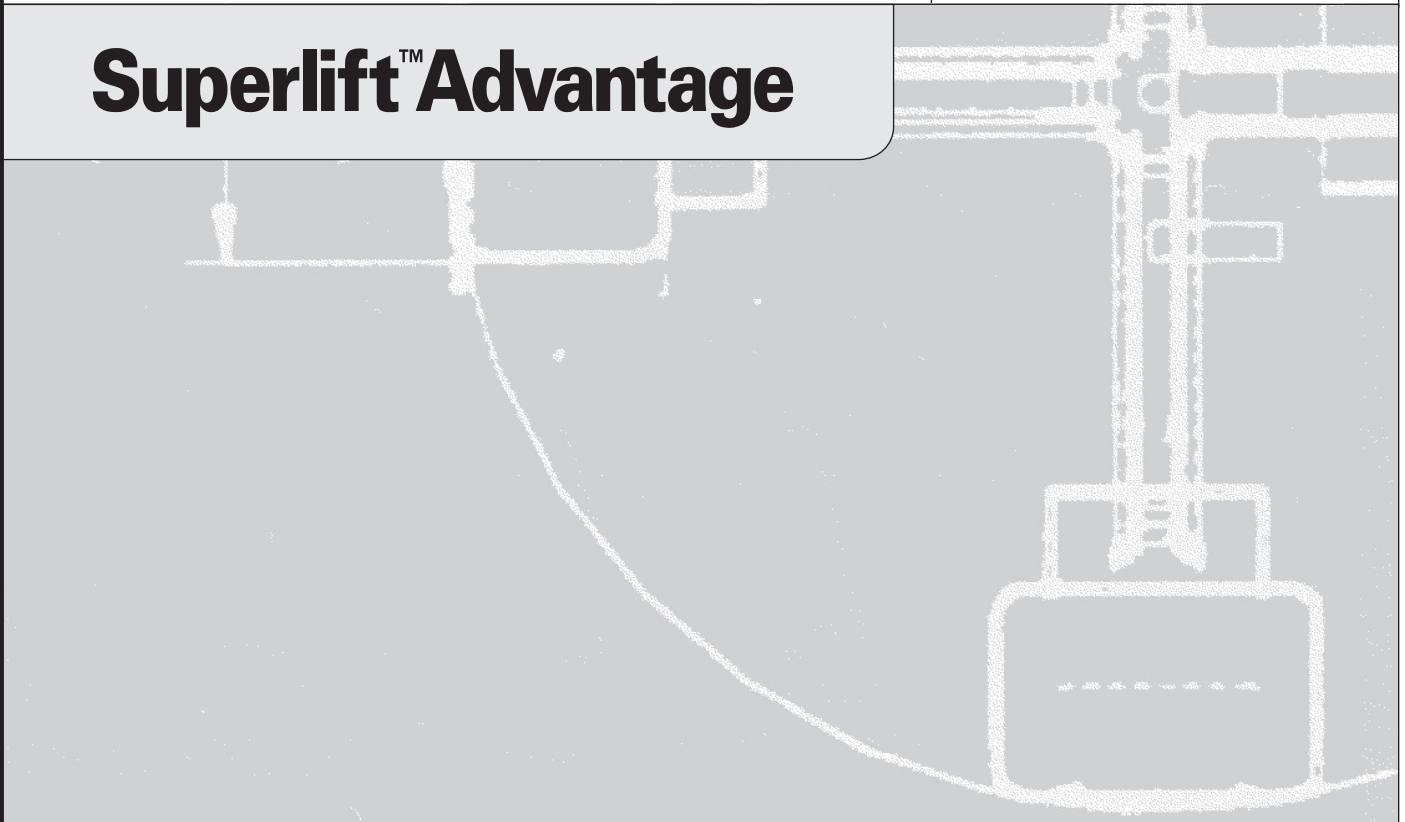

Important

Read, understand and obey these safety rules and operating instructions before operating this machine. Only trained and authorized personnel shall be permitted to operate this machine. This manual should be considered a permanent part of your machine and should remain with the machine at all times. If you have any questions, call Genie Industries.

Contents

	Page
Safety	1
Legend	6
Pre-operation Inspection	8
Function Tests	10
Workplace Inspection	15
Operating Instructions	16
Load Capacity Charts	18
Transport and Lifting Instructions	20
Decals	21
Specifications	24

Contact us:

Internet: <http://www.genielift.com>
e-mail: techpub@genieind.com

Copyright © 1994 by Genie Industries

First Edition: Third Printing, June 1994

Second Edition: Seventh Printing, March 2006

"Genie" and "Superlift" are registered trademarks of Genie Industries in the U.S.A. and many other countries.

 Printed on recycled paper

Printed in U.S.A.

Safety Rules



Warning

Failure to obey the instructions and safety rules in this manual may result in death or serious injury.

Do Not Operate Unless:

- You** learn and practice the principles of safe machine operation contained in this operator's manual.

1 Avoid hazardous situations.

Know and understand the safety rules before going on to the next section.

2 Always perform a pre-operation inspection.

3 Always perform the function tests prior to use.

4 Inspect the workplace.

5 Only use the machine as it was intended.

- You** read, understand and obey:

manufacturer's instructions and safety rules—operator's manual and machine decals

employer's safety rules and worksite regulations

applicable governmental regulations

SAFETY RULES

Fall Hazards

Do not use the machine as a personnel lifting platform or step.

Do not stand on the load handling attachments.

Do not climb on the mast.

Tip-over Hazards

Do not raise the load unless the stabilizers (if equipped) and legs have been fully lowered and locked and the casters are in full contact with the ground.

Do not raise the load unless the leg retainer pins are properly inserted through the leg and the base.

Do not remove the leg retainer pins while the machine is loaded and/or raised.

Do not raise the load unless the machine is on a firm, level surface.

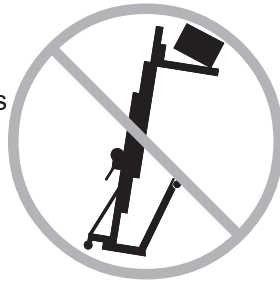

Prior to use, check the work area for drop-offs, holes, bumps, debris, unstable or slippery surfaces or other possible hazardous conditions.

Do not raise the load unless the load handling attachment is properly secured to the machine.

Do not use blocks to level the machine.

Do not move the machine with a raised load, except for minor positioning.

Do not operate the machine in strong or gusty winds. Increasing the load surface area will decrease machine stability in windy conditions.



Do not leave a load raised when windy conditions may occur unless the machine(s) are properly guy-wired.

Do not cause a horizontal force or side load to the machine by raising or lowering a fixed or overhanging load.

SAFETY RULES

Do not place ladders or scaffolding against any part of the machine.

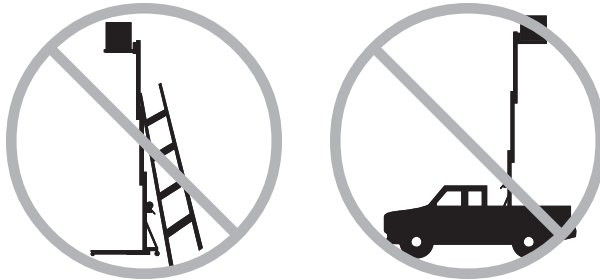

Do not use the machine on a moving or mobile surface or vehicle.

Do not exceed the rated load capacity. See Load Capacity Charts section.

Avoid debris and uneven surfaces while rolling a Genie Superlift with the legs folded up.

Do not replace machine parts critical to stability or structure with items of different weight or specification.

Do not use a straddle base, the flat forks, the vertical barrel stacker or the rotating barrel handler on an SLA-20 or an SLA-25.

Lifting Hazards

Use proper lifting techniques to load or tip the machine.

Use proper lifting techniques when installing or removing the load handling attachments.

Electrocution Hazards

This machine is not electrically insulated and will not provide protection from contact with or proximity to electrical current.



Keep away from the machine if it contacts energized power lines. Personnel must not touch or operate the machine until power lines are shut off.

Maintain safe distances away from electrical power lines and apparatus in accordance with applicable governmental regulations and the following chart.

Voltage	Minimum Safe Approach Distance	
	Feet	Meters
Phase to Phase		
0 to 300V	Avoid Contact	
300V to 50KV	10	3.1
50KV to 200KV	15	4.6
200KV to 350KV	20	6.1
350KV to 500KV	25	7.6
500KV to 750KV	35	10.7
750KV to 1000KV	45	13.7

Allow for mast movement and electrical line sway or sag, and be aware of strong or gusty winds.

Do not use the machine as a ground for welding.

Bodily Injury Hazard

Do not grasp the cable.

SAFETY RULES

Crushing Hazards

Do not raise if the load is not properly centered on the load handling attachment.

Do not raise unless the load is properly secured to the load handling attachment.

Do not stand under or allow personnel under the machine when the load is raised.

Do not stand under the load. The safety brake system (if equipped) will allow the load to drop 1 to 3 feet before locking the columns.

Do not lower the load unless the area below is clear of personnel and obstructions.

Keep hands and fingers away from folding legs and other potential pinch points.

Maintain a firm grasp on the stabilizer when the lock plates are released. The stabilizer will drop.

Maintain a firm grasp on the leg when the retaining pin is removed. The leg will drop.

Maintain a firm grasp on the winch handles until the brake is locked. The brake is locked when the load will not cause the winch handles to turn.

Adjustable Flat Forks

Do not raise the load unless the snap pins are properly inserted in the forks.

**Vertical Barrel Stacker**

Do not raise the load unless the lifting arms are in the correct position for the barrel size.

Do not raise the load unless the lifting arms are correctly positioned between the ribs on the barrel.

Rotating Barrel Handler

Keep hands clear of the rotating gears.

Use proper lifting techniques to lift the barrel handler.

Fork Extensions

Do not raise the load unless the fork extensions are properly secured to the forks.

Collision Hazards

Check the work area for overhead obstructions or other possible hazards.

Do not tilt the machine back unless the area is clear of personnel and obstructions.

Use common sense and planning when transporting the machine on an incline or slope.

Do not load for transport unless the machine and vehicle are on a level surface. Use proper lifting techniques to load the machine.



SAFETY RULES

Damaged Machine Hazards

Do not use a damaged or malfunctioning machine.

Do not use a machine with a worn, frayed, kinked or damaged cable.

Do not use a machine with less than 4 wraps of cable on the winch drum when the carriage is fully lowered.

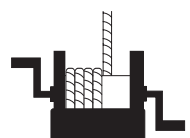

Conduct a thorough pre-operation inspection prior to each use.

Be sure all decals are in place and legible. See Decals section.

Be sure that the operator's manual is complete, legible and in the storage container located on the machine.

Maintain proper lubrication on the winch. See *Genie Superlift Parts and Service Manual* for details. Do not allow oil or grease on braking surfaces.

Do not use any type of lubrication on the column surfaces.

Improper Use Hazard

Never leave a Genie Superlift unattended with a load. Unauthorized personnel may attempt to operate the machine without proper instruction, creating an unsafe condition.

Decal Legend

Genie product decals use symbols, color coding and signal words to identify the following:



Safety alert symbol—used to alert personnel to potential personal injury hazards. Obey all safety messages that follow this symbol to avoid possible injury or death.



Red—used to indicate the presence of an imminently hazardous situation which, if not avoided, will result in death or serious injury.



Orange—used to indicate the presence of a potentially hazardous situation which, if not avoided, could result in death or serious injury.



Yellow with safety alert symbol—used to indicate the presence of a potentially hazardous situation which, if not avoided, may cause minor or moderate injury.



Yellow without safety alert symbol—used to indicate the presence of a potentially hazardous situation which, if not avoided, may result in property damage.



Green—used to indicate operation or maintenance information.

Legend

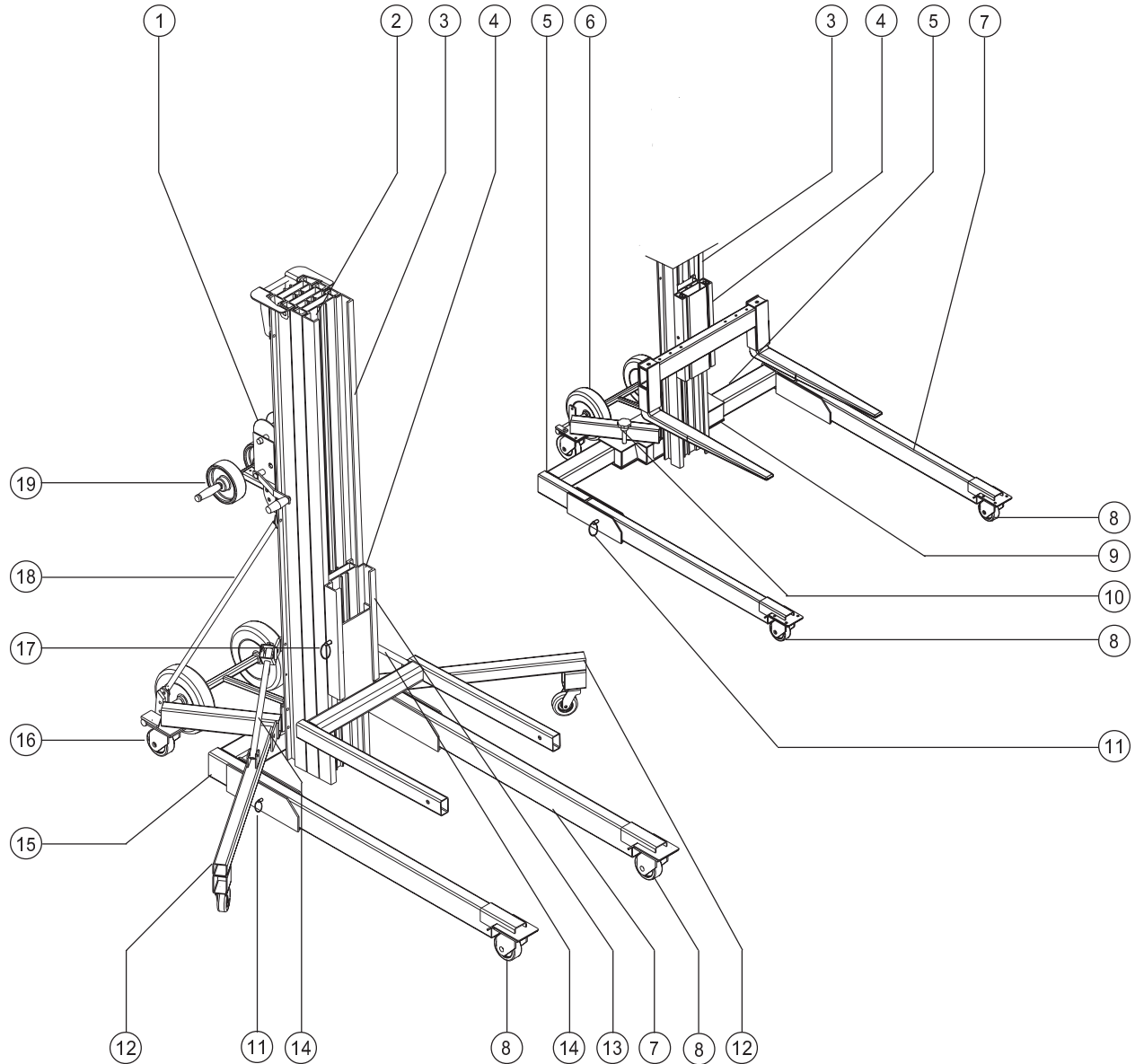

- | | | |
|-------------------------------|--|---|
| 1 Winch | 8 Leg swivel caster | 15 Standard base |
| 2 Cable | 9 Straddle base | 16 Base swivel/lock caster with brake |
| 3 Mast | 10 Arm lock knob | 17 Load handling attachment retaining pin |
| 4 Carriage | 11 Leg retaining pin | 18 Mast brace |
| 5 Adjustable arm | 12 Stabilizer (if equipped) | 19 Loading wheels/steer handles |
| 6 Traveling wheels (optional) | 13 Hold-down bar (on opposite side of machine) | |
| 7 Leg | 14 Stabilizer brace | |

LEGEND

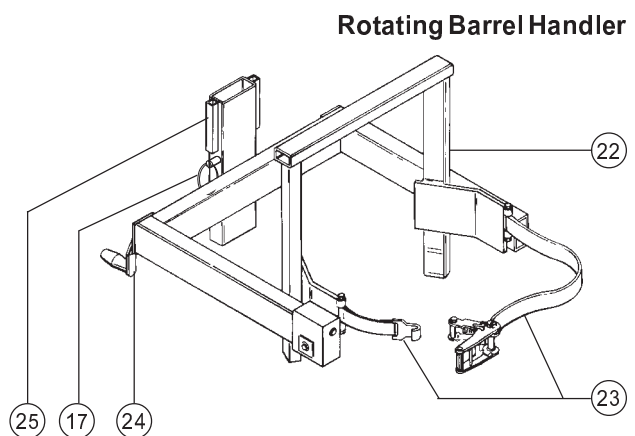
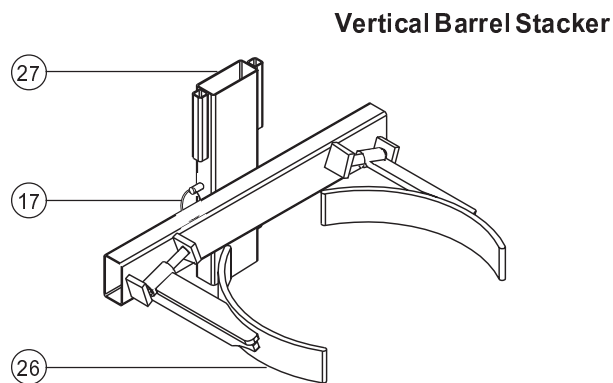
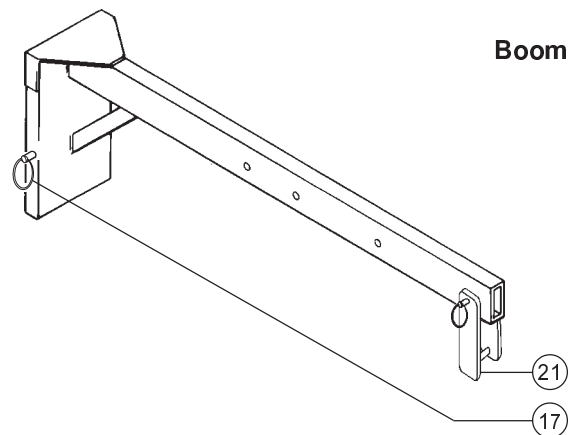
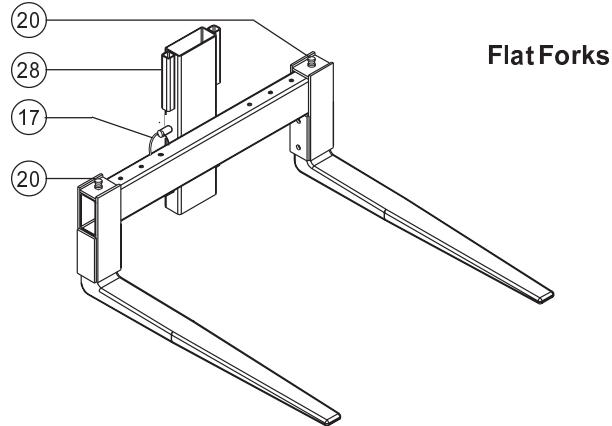
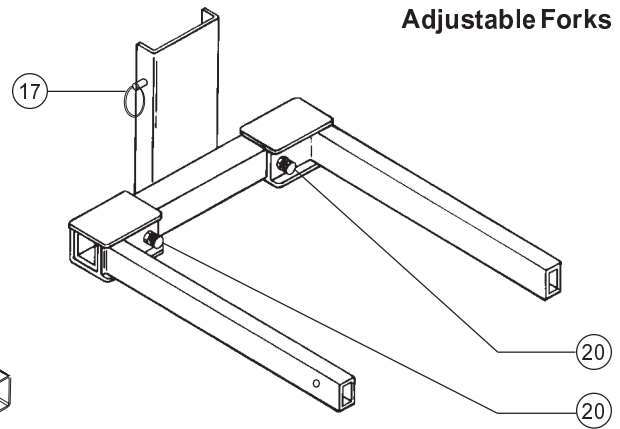
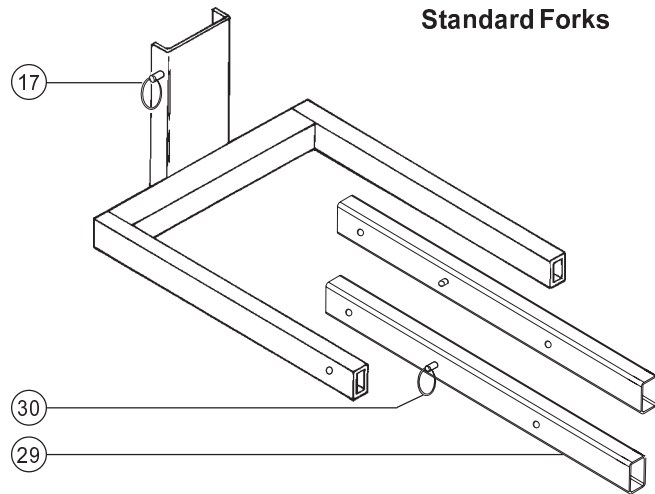

- 20 Snap pin
- 21 Lifting shackle
- 22 Barrel cradle
- 23 Strap and buckle

- 24 Crank handle
- 25 Rotating barrel handler mounting bracket

- 26 Lifting arms
- 27 Vertical barrel stacker mounting bracket

- 28 Forkmounting bracket
- 29 Fork extension
- 30 Fork extension retaining pin

Pre-operation Inspection



Do Not Operate Unless:

- You learn and practice the principles of safe machine operation contained in this operator's manual.
- 1 Avoid hazardous situations.
- 2 Always perform a pre-operation inspection.**
Know and understand the pre-operation inspection before going on to the next section.
- 3 Always perform function tests prior to use.
- 4 Inspect the workplace.
- 5 Only use the machine as it was intended.

Fundamentals

The Pre-operation Inspection is a visual inspection performed by the operator prior to each work shift. This inspection is designed to discover if anything is apparently wrong with a machine before the operator tests it.

Inspect the machine for modifications, damage and loose or missing parts.

A damaged or modified machine must never be used. If damage or any variation from factory delivered condition is discovered, the machine must be tagged and removed from service.

Repairs to the machine may only be made by a qualified service technician, according to the manufacturer's specifications. After repairs are completed, the operator must perform a pre-operation inspection again before going on to the function tests.

PRE-OPERATION INSPECTION

Pre-operation Inspection

- • Be sure that the operator's manual is complete, legible and in the storage container located on the machine.
- • Be sure that all decals are legible and in place. See Decals section.

Check the following components or areas for damage, modifications and improperly installed or missing parts:

- • Winch and related components
- • Base components
- • Legs
- • Stabilizers and latch plates (if equipped)
- • Mast columns
- • Exterior plastic shim for safety brake (if equipped)
- • Carriage hold-down bar
- • Cable anchor
- • Cable and pulleys
- • Wheels and casters
- • Load handling attachments (if equipped)
- • Nuts, bolts and other fasteners
- • Cable (kinks, frays, abrasions)

Check the entire machine for:

- • Dents or damage
- • Corrosion or oxidation
- • Cracks in welds or structural components
- • Be sure that all structural and other critical components are present and all associated fasteners and pins are in place and properly tightened.
- • Be sure there is a minimum of 4 wraps of cable around the winch drum when the carriage is fully lowered.

Function Tests



Do Not Operate Unless:

- You learn and practice the principles of safe machine operation contained in this operator's manual.
- 1 Avoid hazardous situations.
- 2 Always perform a pre-operation inspection.
- 3 **Always perform function tests prior to use.**
Know and understand the function tests before going on to the next section.
- 4 Inspect the workplace.
- 5 Only use the machine as it was intended.

Fundamentals

The Function Tests are designed to discover any malfunctions before the machine is put into service. The operator must follow the step-by-step instructions to test all machine functions.

A malfunctioning machine must never be used. If malfunctions are discovered, the machine must be tagged and removed from service. Repairs to the machine may only be made by a qualified service technician, according to the manufacturer's specifications.

After repairs are completed, the operator must perform a pre-operation inspection and function tests again before putting the machine into service.

FUNCTION TESTS

Function Tests

- 1 Select a test area that is firm, level and free of obstructions.

Setup

Machines Without Stabilizers

- 1 Remove the leg retainer pin and lower the leg to the down position. Insert the pin through the leg and base.



Machines With Stabilizers

- 1 Push down to release the stabilizer lock plates and lower the stabilizers until the casters are in full contact with the ground. Be sure the stabilizers are locked in the down position.
- 2 Remove the leg retainer pin and lower the leg to the down position. Insert the pin through the leg and base.



Straddle Base

- 1 Place a 2 inch / 5.1 cm block under one leg swivel caster.
- 2 Loosen the arm lock knob on the opposite adjustable arm. Push down on the lock knob.
- 3 Position the adjustable arm to the desired width.
- 4 Tighten the arm lock knob while supporting the leg assembly.
- 5 Repeat steps 1-4 for the other arm.

Load Handling Attachments

Standard Forks and Standard Fork Options

- 1 Place the forks inside the carriage.
- 2 Insert the retaining pin.



Load Platform with Standard Forks

- 1 Place the load platform on the standard forks.

Pipe Cradle

- 1 Attach the pipe cradles to the forks. Be sure the fasteners are tightened.

Fork Extensions

- 1 Slide each extension tube onto the fork.
- 2 Adjust to the desired position and insert the retaining pins.

FUNCTION TESTS

Adjustable Forks and Adjustable Fork Options

- 1 Place the forks inside the carriage.
- 2 Insert the retaining pin.

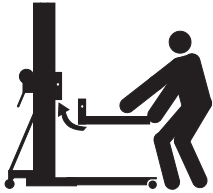

- 3 Adjust the forks to the desired width and be sure the snap pin is properly inserted in each fork.

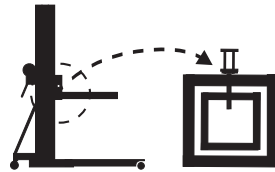
**Load Platform with Adjustable Forks**

- 1 Adjust the forks to a width of 23 inches / 58.4 cm.
- 2 Place the load platform on the adjustable forks.

Pipe Cradle

- 1 Attach the pipe cradles to the forks. Be sure the fasteners are tightened.

Fork Extensions

- 1 Slide each extension tube onto the forks.
- 2 Adjust to the desired position and insert the retaining pins.

Flat Forks

- 1 Place the fork mounting bracket inside the carriage.
- 2 Insert the retaining pin.

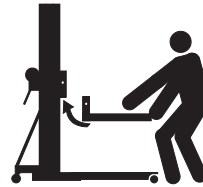

- 3 Adjust the forks to the desired width and be sure the snap pin is properly inserted in each fork.

**Standard Boom**

- 1 Place the boom inside the carriage.
- 2 Insert the retaining pin.

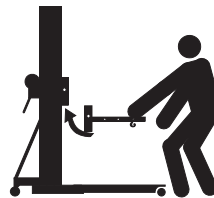

- 3 Attach the lifting shackle to the desired hole on the boom.

FUNCTION TESTS

Vertical Barrel Stacker

- 1 Place the barrel stacker mounting bracket inside the carriage.
- 2 Insert the retaining pin.
- 3 Adjust the lifting arms by raising, moving and lowering the arm. Adjust the arms to the desired position:

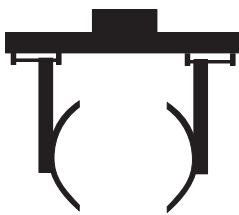

Inside position:
30 gallon barrels

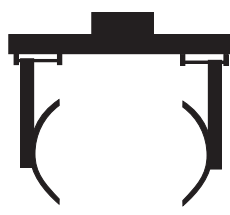

Outside position:
55 gallon barrels

- 4 Push the barrel stacker against the barrel until the lifting arms completely surround the barrel. Lifting arms must be positioned between the ribs on the barrel.

Rotating Barrel Handler

- 1 Using proper lifting techniques, place the rotating barrel handler on the ground between the legs of the machine.
- 2 Lower the carriage down over the mounting bracket. Insert the mounting bracket retaining pin.
- 3 Position the barrel cradle by turning the crank handle.

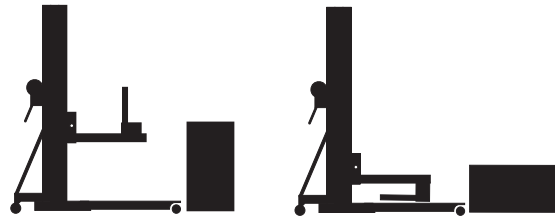

- 4 Push the barrel cradle against the barrel.
- 5 Loosen the buckle and attach the strap to the buckle. Use the ratchet on the buckle to tighten the strap. Be sure the strap is tight.
- 6 The winch will raise and lower the barrel and the crank handle will rotate the barrel.

FUNCTION TESTS

Test One-Speed Winch Operation

- 1 Install a load handling attachment.
- 2 Raise the carriage by firmly grasping the winch handles and rotating them towards the mast.
- ⊙ Result: The winch should operate smoothly, free of hesitation or binding.
- 3 Lower the carriage by firmly grasping the winch handles and rotating them away from the mast. After lowering to the desired position, turn the winch handles toward the mast (raise the load) $1/4$ turn to set the brakes.
- ⊙ Result: The winch should operate smoothly, free of hesitation or binding.

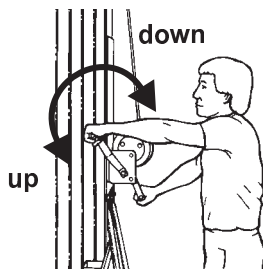
**Test Two-Speed Winch Operation**

- 1 Install a load handling attachment.
- 2 Shift the winch to the slow speed.
- 3 Raise the carriage by firmly grasping the winch handles and rotating them towards the mast.
- ⊙ Result: The winch should operate smoothly, free of hesitation or binding.
- 4 Lower the carriage by firmly grasping the winch handles and rotating them away from the mast. After lowering to the desired position, turn the winch handles toward the mast (raise the load) $1/4$ turn to set the brakes.
- ⊙ Result: The winch should operate smoothly, free of hesitation or binding.
- 5 Shift the winch to the fast speed and repeat steps 3 and 4.

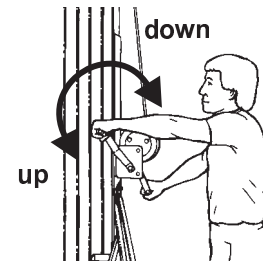
**Test Mast Sequencing**

- 1 Install a load handling attachment.
- 2 Raise the carriage to full height by firmly grasping the winch handles and rotating them towards the mast.
- ⊙ Result: The carriage should raise to the top of the front mast section, followed in consecutive order by each mast section.
- 3 Fully lower the carriage. After lowering to the desired position, turn the winch handles toward the mast (raise the load) $1/4$ turn to set the brakes.

Workplace Inspection



Do Not Operate Unless:

- You learn and practice the principles of safe machine operation contained in this operator's manual.
- 1 Avoid hazardous situations.
- 2 Always perform a pre-operation inspection.
- 3 Always perform function tests prior to use.
- 4 Inspect the workplace.**
Know and understand the workplace inspection before going on to the next section.
- 5 Only use the machine as it was intended.

Be aware of and avoid the following hazardous situations:

- Drop-offs or holes
- Bumps and floor obstructions
- Debris
- Overhead obstructions and high voltage conductors
- Hazardous locations
- Inadequate surface support to withstand all load forces imposed by the machine
- Wind and weather conditions
- All other possible unsafe conditions

Fundamentals

The Workplace Inspection helps the operator determine if the workplace is suitable for safe machine operation. It should be performed by the operator prior to moving the machine to the workplace.

It is the operator's responsibility to read and remember the workplace hazards, then watch for and avoid them while moving, setting up and operating the machine.

Operating Instructions



Do Not Operate Unless:

- You learn and practice the principles of safe machine operation contained in this operator's manual.
- 1 Avoid hazardous situations.
- 2 Always perform a pre-operation inspection.
- 3 Always perform function tests prior to use.
- 4 Inspect the workplace.
- 5 **Only use the machine as it was intended.**

Fundamentals

Using the machine for anything other than lifting material is unsafe.

If more than one operator is expected to use a machine at different times in the same work shift, each operator is expected to follow all safety rules and instructions in the operator's manual. That means every new operator should perform a pre-operation inspection, function tests and a workplace inspection before using the machine.

OPERATING INSTRUCTIONS

Setup

Select an area that is firm, level and free of obstructions.

Follow the Setup procedures in the Functions Test section.

Raising and Lowering Load

- 1 Center the load on the load handling attachment. See Load Capacity Charts section.
- 2 Secure the load to the load handling attachment.
- 3 Raise the load by firmly grasping the winch handles and rotating them toward the mast. Do not allow the cable to wind unevenly onto the drum.
- 4 Lower the load by firmly grasping the winch handles and rotating them away from the mast. After lowering to the desired position, turn the winch handles toward the mast (raise the load) $\frac{1}{4}$ turn to set the brakes

Moving Machine with a Load

It is best to move the machine on the worksite with no load. Moving a raised load should be restricted to positioning for loading and unloading. If it is necessary to move the machine with a raised load, understand and obey the following safety rules:

- Make sure the area is level and clear of obstructions
- Make sure the load is centered on the load handling attachment
- Make sure the load is secured to the load handling attachment
- Avoid sudden starts and stops
- Travel with the load in the lowest possible position
- Keep personnel away from the machine and load

After Each Use

To prepare the Genie Superlift for storage, follow the Setup procedure in reverse order.

Select a safe storage location - firm level surface, weather protected, clear of obstruction and traffic.

Load Capacity Charts



Observe and Obey:

- ☑ Failure to properly position the load may result in death or serious injury.
- ☑ Verify that the load you wish to raise does not exceed the maximum load for your load center. See the Load Capacity Chart on the next page.

⚠ WARNING Tip-over hazard. Raising a load that exceeds the machine capacity may result in death or serious injury.

- ☑ A load center is defined as the balancing point (center of gravity) of a load and must be positioned within the load center zone.

⚠ WARNING Tip-over hazard. Failure to position the load center within the load center zone may result in death or serious injury.

Forks

Load Positioning Instructions

- 1 Determine the weight of the load and the location of its load center.
- 2 Measure to the load center from the side of the load that will be closest to the carriage.
- 3 Refer to the chart on the next page to determine if the machine is capable of lifting the weight at the location on the forks.
- 4 Place the load so that it rests on the forks, as close to the carriage as possible.
- 5 Position the load so that the load center is within the load center zone.
- 6 Secure the load to the forks.

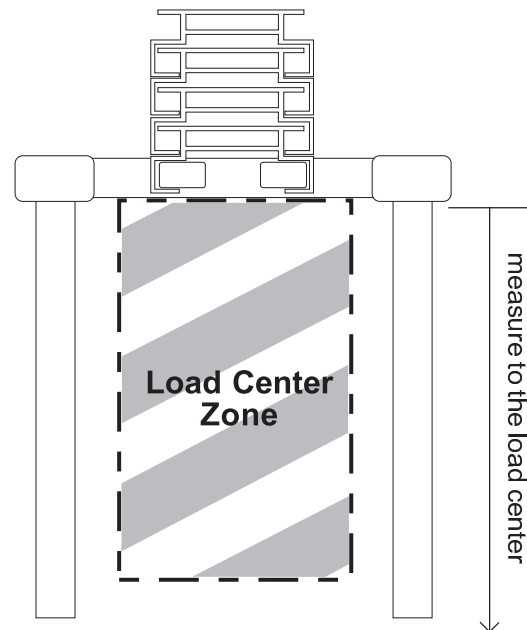

See the chart on the next page for maximum load centers for standard forks, adjustable forks and flat forks.

LOAD CAPACITY CHARTS

Boom

Load Positioning Instructions

- 1 Determine the weight of the load and the location of its load center.
- 2 Refer to the chart below to determine if the machine is capable of lifting the weight at the location on the boom.
- 3 Secure the load to the lifting shackle on the boom.

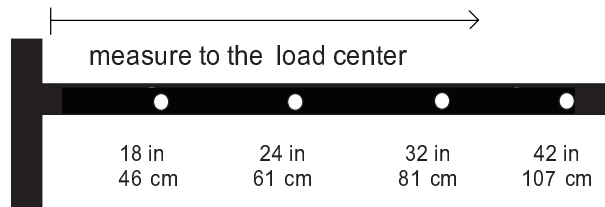

Maximum Load Centers

(measure from the front of the carriage)

Standard Forks:	24 in	61 cm
Adjustable Forks:	24 in	61 cm
Boom:	42 in	107 cm
Flat Forks:	28 in	71 cm
Vertical Barrel Stacker:	equivalent to 24 in	
Rotating Barrel Handler:	equivalent to 38 in	
30 gallon barrels	equivalent to 30 in	
55 gallon barrels	equivalent to 30 in	
Load Platform:	24 in	61 cm
Pipe Cradle:	18 in	46 cm
Fork Extensions:	42 in	107 cm

Load Capacity Chart														
Load Center														
inches		18	20	22	24	26	28	30	32	34	36	38	40	42
cm		46	51	56	61	66	71	76	81	86	91	97	102	107
Model														
SLA-5	lbs	1000	1000	1000	1000	938	875	813	750	670	590	510	430	350
	kg	454	454	454	454	425	397	369	340	304	268	231	195	159
SLA-10	lbs	1000	1000	1000	1000	913	825	738	650	600	550	500	450	400
	kg	454	454	454	454	414	374	335	295	272	249	227	204	181
SLA-15	lbs	800	800	800	800	763	725	688	650	620	590	560	530	500
	kg	363	363	363	363	346	329	312	295	281	268	254	240	227
SLA-20	lbs	800	733	667	600	563	525	488	450	430	410	390	370	350
	kg	363	332	303	272	255	238	221	204	195	186	177	168	159
SLA-25	lbs	650	583	517	450	425	400	375	350	330	310	290	270	250
	kg	295	264	235	204	193	181	170	159	150	141	132	122	113

Transport and Lifting Instructions



Observe and Obey:

- ☑ The transport vehicle must be parked on a level surface.
- ☑ The transport vehicle must be secured to prevent rolling while the machine is being loaded.
- ☑ Be sure the vehicle capacity, loading surfaces and chains or straps are sufficient to withstand the machine weight. See the serial plate for machine weight.
- ☑ The machine must be secured to the transport vehicle with chains or straps of ample load capacity.

Loading the Machine

Be sure to remove the load handling attachment from the machine and place the stabilizers in the stored position.

- 1 Fully lower the carriage, to lock for transport.
- 2 Rotate the carriage hold-down bar over the carriage.
- 3 Raise the carriage until it contacts the carriage hold-down bar.
- 4 Adjust the loading wheels to the desired position. Be sure the pin is properly inserted.

- 5 Lock the rear base casters.



- 6 Place the machine against the vehicle. Use proper lifting techniques to load the machine into the transport vehicle. Be sure to check that the carriage is locked in the lowered position.



- 7 Use a minimum of 1 chain or strap to secure the machine to the truckbed. Place the chain or strap over the mast. Placing the chain or strap over the legs can damage the legs.



- 8 To unload, follow the loading instructions in reverse order.

Loading Machine with a Crane

Be sure to place the legs and stabilizers in the stored position.

Be sure to inspect the machine and remove any loose or unsecured items.

Use the lifting bracket on the top of the rear mast column.

Always place the lifting hook through the lifting bracket so that it points away from the machine.

Decals

Decal Inspection

Use the pictures on the next two pages to verify that all decals are legible and in place. Below is a numerical list with quantities and descriptions.

Part No.	Description	Quantity
31072	Label - Operator's Manual Container	1
32686	Warning - Machine Safety & Setup	1
32687	Warning - Standard Forks Safety/Setup	1
32689	Cosmetic - SLA-5	2
32690	Cosmetic - SLA-10	2
32691	Cosmetic - SLA-15	2
32692	Cosmetic - SLA-20	2
32693	Cosmetic - SLA-25	2
32714	Warning - Adjustable Forks Safety/Setup	1
32715	Notice - Flat Forks Setup	1
32716	Notice - Boom Setup	1
32717	Warning - Boom Safety	1
32718	Warning - Flat Forks Safety	1

Part No.	Description	Quantity
32770	Notice - Two Speed Shift Instructions	1
32771	Warning - Vertical Barrel Stacker Safety	1
32772	Notice - Vertical Barrel Stacker Setup	1
32773	Warning - Rotating Barrel Handler Safety	1
32774	Notice - Rotating Barrel Stacker Setup	1
32775	Warning - Fall Hazard, Load Platform	1
32885	Warning - Silent Winch	1
32938	Label - Use This Winch	1
32939	Warning - Crushing Hazard, Brake Lock	1
33468	Warning - No Riders	1
52675	Caution - Damaged Machine Hazard	1
52983	Cosmetic - Superlift Advantage Logo	2

DECALS

■ Shading indicates the decal is on the other side of the machine.

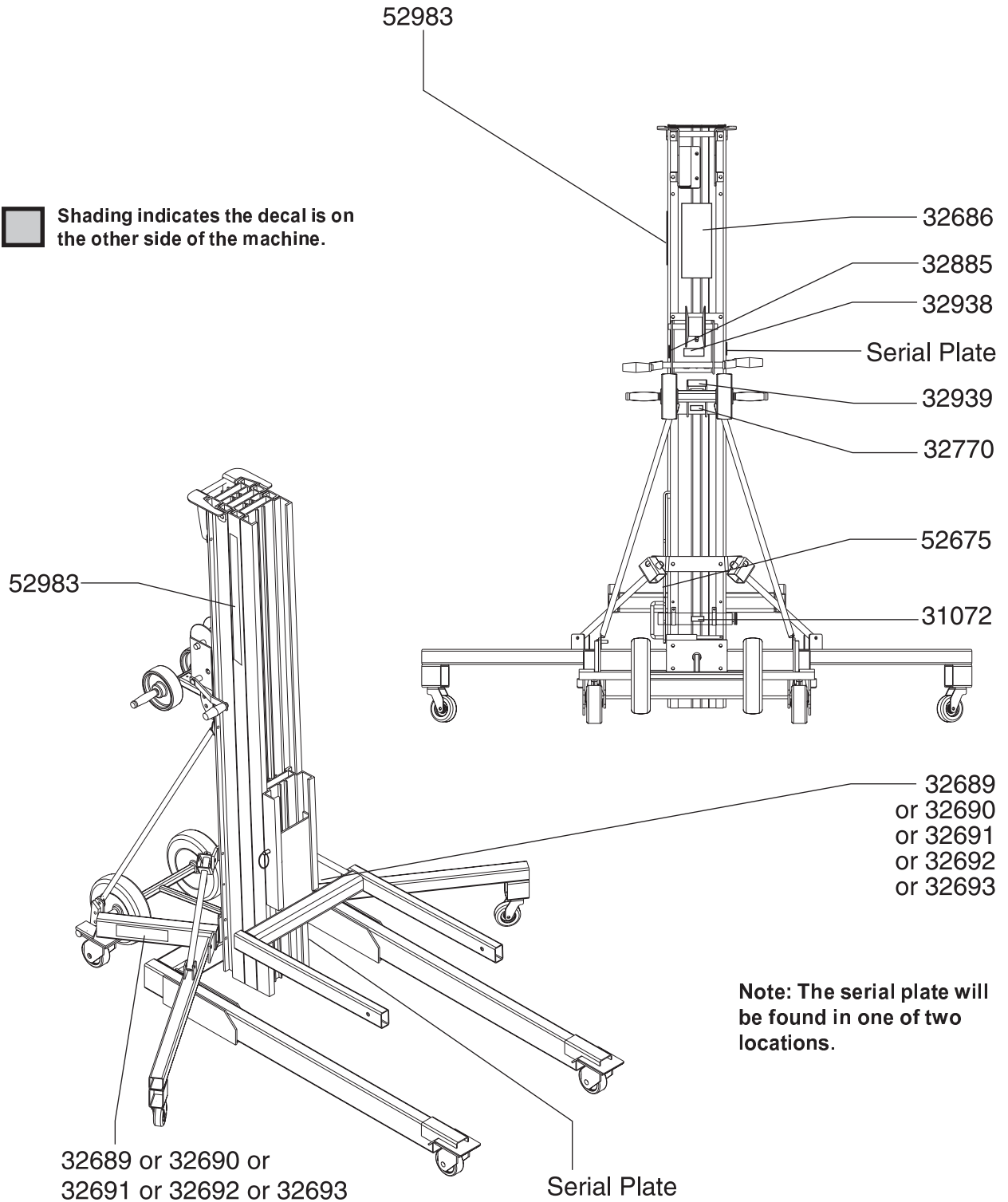

DECALS

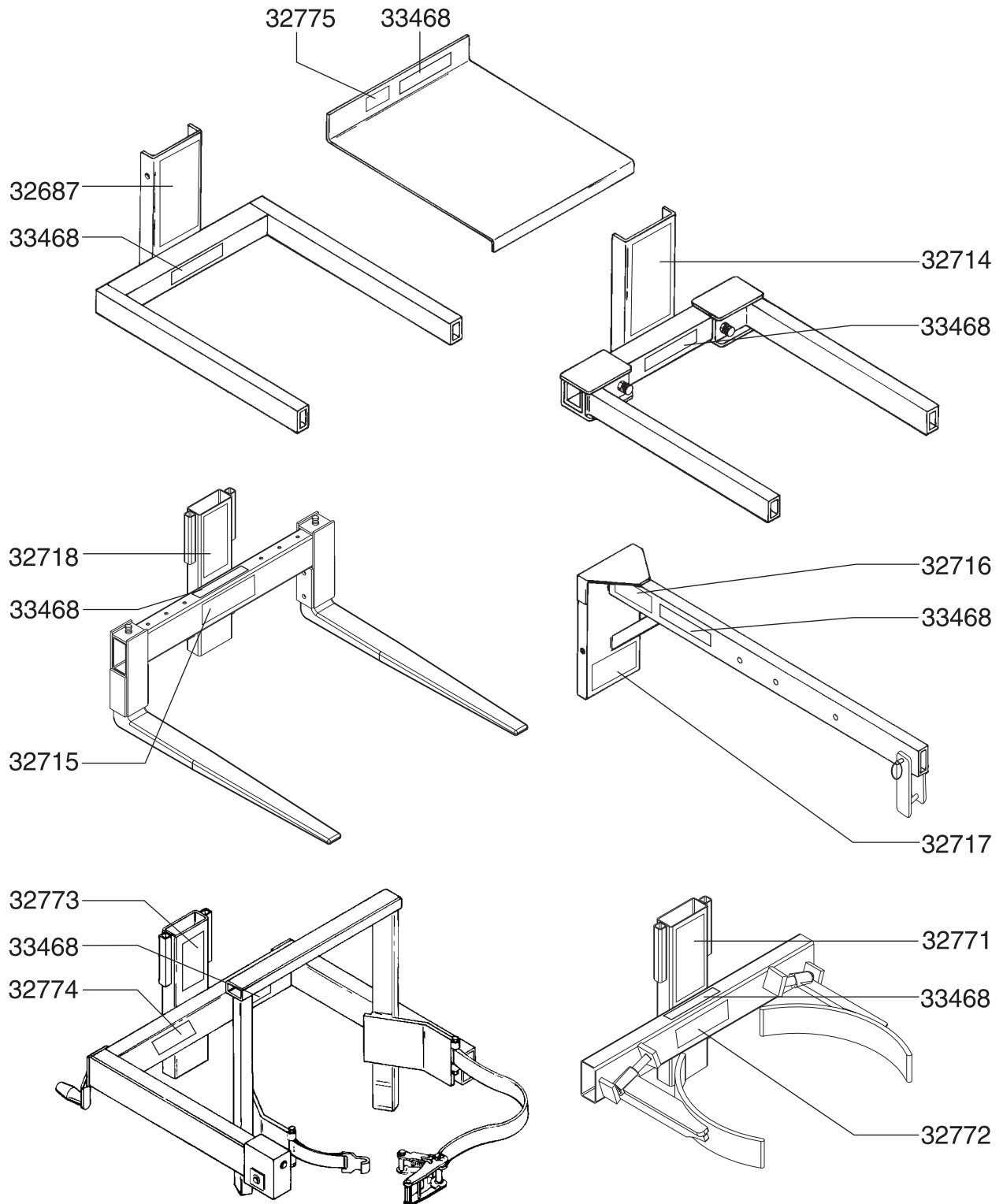

Specifications

Model	SLA-5	SLA-10	SLA-15	SLA-20	SLA-25
Height-Stowed	78 ¹ / ₂ in 2 m	78 ¹ / ₂ in 2 m	78 ¹ / ₂ in 2 m	78 ¹ / ₂ in 2 m	78 ¹ / ₂ in 2 m
Width Standard Base	31 ¹ / ₂ in 80 cm	31 ¹ / ₂ in 80 cm	31 ¹ / ₂ in 80 cm	31 ¹ / ₂ in 80 cm	31 ¹ / ₂ in 80 cm
Width-stabilizers lowered Standard Base	78 ⁵ / ₈ in 2 m	78 ⁵ / ₈ in 2 m	78 ⁵ / ₈ in 2 m	78 ⁵ / ₈ in 2 m	78 ⁵ / ₈ in 2 m
Width-Min Straddle Base	31 ¹ / ₂ in 80 cm	31 ¹ / ₂ in 80 cm	31 ¹ / ₂ in 80 cm	NA	NA
Width-Max Straddle Base	58 in 1.5 m	58 in 1.5 m	58 in 1.5 m	NA	NA
Length-Stowed	29 in 74 cm	29 in 74 cm	29 in 74 cm	29 in 74 cm	31 in 79 cm
Length-Operating	59 ¹ / ₂ in 1.5 m	59 ¹ / ₂ in 1.5 m	72 ¹ / ₂ in 1.8 m	80 ¹ / ₂ in 2 m	80 ¹ / ₂ in 2 m
Ground Clearance	2 in 50.8 mm	2 in 50.8 mm	2 in 50.8 mm	2 in 50.8 mm	2 in 50.8 mm
Load Capacity at 18 inch / 46 cm load center	1000 lbs 454 kg	1000 lbs 454 kg	800 lbs 363 kg	800 lbs 363 kg	650 lbs 295 kg
Note: see Load Capacity Charts section for load capacities at other load centers.					
Net Weight - Standard Base	215 lbs 97.5 kg	260 lbs 117.9 kg	317 lbs 143.8 kg	405 lbs 183.7 kg	450 lbs 204.1 kg
Net Weight - Straddle Base	258 lbs 117.0 kg	303 lbs 137.4 kg	360 lbs 163.3 kg	NA	NA
Load Handling Attachments	Length	Width	Depth	Net Weight	
Standard Forks	27 ¹ / ₂ in 70 cm	23 ¹ / ₂ in 60 cm	2 ¹ / ₂ in 6.4 cm	38 lbs 17.2 kg	
Adjustable Forks	27 ¹ / ₂ in 70 cm	11 ¹ / ₂ in to 30 in 29 cm to 76 cm	2 ¹ / ₂ in 6.4 cm	52.5 lbs 23.8 kg	
Flat Forks	32 in 81 cm	16 in to 31 in 41 cm to 79 cm	1 ¹ / ₂ in 3.8 cm	73 lbs 33.1 kg	
Boom	18 in to 42 in 46 cm to 1.1 m	1 ¹ / ₂ in 4 cm	6 ¹ / ₂ in 16.5 cm	34.5 lbs 15.6 kg	
Vertical Barrel Stacker	21 in 53 cm	29 in 74 cm	NA	50.5 lbs 22.9 kg	
Rotating Barrel Handler	29 in 74 cm	31 in 79 cm	NA	90 lbs 40.8 kg	
Pipe Cradle	27 ¹ / ₂ in 70 cm	24 ¹ / ₂ in 63 cm	6 in 15.2 cm	10 lbs 4.5 kg	
Load Platform	27 ¹ / ₂ in 70 cm	23 ¹ / ₂ in 60 cm	2 ¹ / ₂ in 6.4 cm	26.5 lbs 12 kg	
Fork extensions (each)	30 in 76 cm	2 in 5 cm	3 in 7.6 cm	4.5 lbs 2 kg	

SPECIFICATIONS

Dimensions		SLA-5	SLA-10	SLA-15	SLA-20	SLA-25
Standard Forks	forks down	4 ft 10 ¹ / ₂ in 1.5 m	9 ft 9 in 3 m	14 ft 7 ¹ / ₂ in 4.5 m	19 ft 6 in 5.9 m	24 ft 4 in 7.4 m
	forks up	6 ft 7 in 2 m	11 ft 5 ¹ / ₂ in 3.5 m	16 ft 4 in 5 m	21 ft 2 ¹ / ₂ in 6.5 m	26 ft ¹ / ₂ in 7.9 m
Adjustable Forks	forks down	4 ft 10 ¹ / ₂ in 1.5 m	9 ft 9 in 3 m	14 ft 7 ¹ / ₂ in 4.5 m	19 ft 6 in 6 m	24 ft 4 in 7.4 m
	forks up	6 ft 7 in 2 m	11 ft 5 ¹ / ₂ in 3.5 m	16 ft 4 in 5 m	21 ft 2 ¹ / ₂ in 6.5 m	26 ft ¹ / ₂ in 7.9 m
Flat Forks		4 ft 10 ¹ / ₂ in 1.5 m	9 ft 9 in 3 m	14 ft 7 ¹ / ₂ in 4.5 m	NA	NA
Boom		5 ft 10 ¹ / ₂ in 1.8 m	10 ft 9 in 3.3 m	15 ft 7 ¹ / ₂ in 4.8 m	20 ft 6 in 6.2 m	24 ft 4 in 7.4 m
Note: measured from ground to bottom of shackle						
Vertical Barrel Stacker	30 gallon	4 ft 1.2 m	8 ft 10 in 2.7 m	13 ft 9 in 4.2 m	NA	NA
	55 gallon	3 ft 10 in 1.2 m	8 ft 8 in 2.6 m	13 ft 7 in 4.1 m		
Note: measured from ground to bottom of barrel						
Rotating Barrel Handler	55 gallon	3 ft 10 in 1.2 m	8 ft 8 in 2.6 m	13 ft 7 in 4.1 m	NA	NA
	30 gallon	3 ft 10 in 1.2 m	8 ft 8 in 2.6 m	13 ft 7 in 4.1 m	NA	NA
Note: measured from ground to bottom of barrel						
Load Platform	forks down	4 ft 10 ¹ / ₂ in 1.5 m	9 ft 9 in 3 m	14 ft 7 ¹ / ₂ in 4.5 m	19 ft 6 in 6 m	24 ft 4 in 7.4 m
	forks up	6 ft 7 in 2 m	11 ft 5 ¹ / ₂ in 3.5 m	16 ft 4 in 5 m	21 ft 2 ¹ / ₂ in 6.5 m	26 ft ¹ / ₂ in 7.9 m
Note: can be used with standard forks and adjustable forks only						
Pipe Cradle Option	handles round objects up to 30 in / 76 cm in diameter					
Note: can be used with standard forks and adjustable forks only (see above for working heights)						
Non-marking Fork Option						
Note: can be used with standard forks and adjustable forks only (see above for working heights)						
Fork Extension Option	adds 6 ¹ / ₄ to 25 inches / 15 to 64 cm of length to forks					
Note: can be used with standard forks and adjustable forks only (see above for working heights)						
Airborne Noise Emissions by Machinery		85 dB	85 dB	85 dB	85 dB	85 dB
Maximum sound level at normal operating workstations (A-weighted)						

Genie Scandinavia Phone +46 31 575100 Fax +46 31 579020
Genie France Phone +33 (0)2 37 26 09 99 Fax +33 (0)2 37 26 09 98
Genie Iberica Phone +34 93 579 5042 Fax +34 93 579 5059
Genie Germany Phone +49 (0)4202 88520 Fax +49 (0)4202 8852-20
Genie U.K. Phone +44 (0)1476 584333 Fax +44 (0)1476 584334
Genie Mexico City Phone +52 55 5666 5242 Fax +52 55 5666 3241

Genie North America
 Phone 425.881.1800
 Toll Free USA and Canada
 800.536.1800
 Fax 425.883.3475

Genie Australia Pty Ltd.
 Phone +61 7 3375 1660
 Fax +61 7 3375 1002

Genie China
 Phone +86 21 53852570
 Fax +86 21 53852569

Genie Malaysia
 Phone +65 98 480 775
 Fax +65 67 533 544

Genie Japan
 Phone +81 3 3453 6082
 Fax +81 3 3453 6083

Genie Korea
 Phone +82 25 587 267
 Fax +82 25 583 910

Genie Brasil
 Phone +55 11 41 665 755
 Fax +55 11 41 665 754

Genie Holland
 Phone +31 183 581 102
 Fax +31 183 581 566

Distributed By: