



# *Service Manual*

Serial Number Range

***Superlift<sup>TM</sup>***  
***Advantage***

from SLA04-25259

Part No. 115407

Rev A

February 2009

---

# Introduction

---

## Important

Read, understand and obey the safety rules and operating instructions in the appropriate Operator's Manual on your machine before attempting any maintenance or repair procedure.

This manual provides detailed scheduled maintenance information for the machine owner and user. It also provides troubleshooting and repair procedures for qualified service professionals.

Basic mechanical skills are required to perform most procedures. However, several procedures require specialized skills, tools, lifting equipment and a suitable workshop. In these instances, we strongly recommend that maintenance and repair be performed at an authorized Genie dealer service center.

---

## Technical Publications

Genie Industries has endeavored to deliver the highest degree of accuracy possible. However, continuous improvement of our products is a Genie policy. Therefore, product specifications are subject to change without notice.

Readers are encouraged to notify Genie of errors and send in suggestions for improvement. All communications will be carefully considered for future printings of this and all other manuals.

---

## Contact Us:

PO Box 97030  
Redmond, WA 98073-9730 USA

www.genieindustries.com  
e-mail: awp.techpub@terex.com

---

## Serial Number Information

Genie Industries offers the following Service Manuals for these models:

Title	Part No.
Genie Superlift Advantage Parts and Service Manual, First Edition (before serial number SL04-25259) .....	32283
Genie Superlift Advantage Parts and Service Manual, Second Edition (from serial number SLA04-25259) .....	*80170

\*Note: Genie Superlift Advantage Service Manual 115407 and Genie Superlift Advantage Part's Manual 115408 replaces Genie Superlift Advantage Parts and Service Manual 80170.

---

Copyright © 1994 by Genie Industries

115407 Rev A February 2009  
Third Edition, First Printing

"Genie" is a registered trademark of Genie Industries in the USA and many other countries.  
"SLA" is a trademark of Genie Industries.

 Printed on recycled paper

Printed in U.S.A.

## Serial Number Legend

**Genie**  
A TEREX COMPANY  
Genie Industries  
18340 NE 76th Street  
Redmond, WA 98052 USA

**Model:** SLA-20

**Serial Number:** SLA07-12345  
**Manufacture Date:** 01/11/2007  
**Electrical Schematic:** N/A

**Country of manufacture:** USA

**CE**<sub>99</sub>

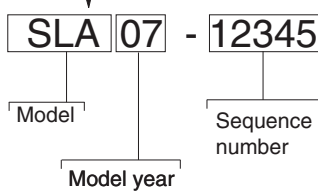

The diagram shows the serial number SLA07-12345 broken down into its components. 'SLA' is labeled as the Model, '07' as the Model year, and '12345' as the Sequence number. An arrow from the Genie logo box points to this diagram.

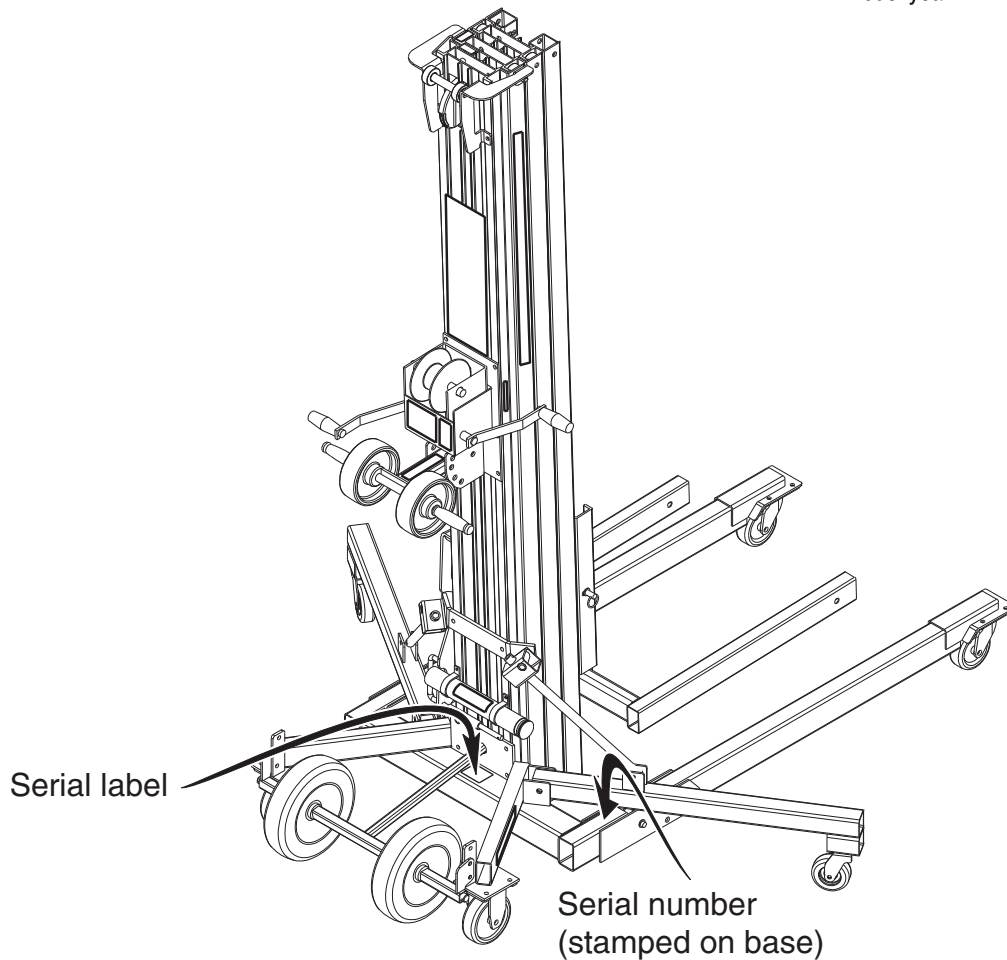

---

# Safety Rules



## Warning

Failure to obey the instructions and safety rules in this manual and the *Genie Superlift Advantage Operator's Manual* could result in death or serious injury.

Many of the hazards identified in the operating instruction manual are also safety hazards when maintenance and repair procedures are performed.

## Do Not Perform Maintenance Unless:

- You are trained and qualified to perform maintenance on this machine.
- You read, understand and obey:
  - manufacturer's instructions and safety rules
  - employer's safety rules and worksite regulations
  - applicable governmental regulations
- You have the appropriate tools, lifting equipment and a suitable workshop.

## SAFETY RULES

## Personal Safety

Any person working on or around a machine must be aware of all known safety hazards. Personal safety and the continued safe operation of the machine should be your top priority.



Read each procedure thoroughly. This manual and the decals on the machine, use signal words to identify the following:



Safety alert symbol—used to alert personnel to potential personal injury hazards. Obey all safety messages that follow this symbol to avoid possible injury or death.



Indicates an imminently hazardous situation which, if not avoided, will result in death or serious injury.



Indicates a potentially hazardous situation which, if not avoided, could result in death or serious injury.



Indicates a potentially hazardous situation which, if not avoided, may cause minor or moderate injury.



Indicates a potentially hazardous situation which, if not avoided, may result in property damage.



Be sure to wear protective eye wear and other protective clothing if the situation warrants it.



Be aware of potential crushing hazards such as moving parts, free swinging or unsecured components when lifting or placing loads. Always wear approved steel-toed shoes.

## Workplace Safety



Be sure to keep sparks, flames and lighted tobacco away from flammable and combustible materials like battery gases and engine fuels. Always have an approved fire extinguisher within easy reach.



Be sure that all tools and working areas are properly maintained and ready for use. Keep work surfaces clean and free of debris that could get into machine components and cause damage.



Be sure any forklift, overhead crane or other lifting or supporting device is fully capable of supporting and stabilizing the weight to be lifted. Use only chains or straps that are in good condition and of ample capacity.



Be sure that fasteners intended for one time use (i.e., cotter pins and self-locking nuts) are not reused. These components may fail if they are used a second time.



Be sure to properly dispose of old oil or other fluids. Use an approved container. Please be environmentally safe.



Be sure that your workshop or work area is properly ventilated and well lit.

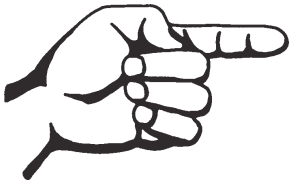

This page intentionally left blank.

# Table of Contents

---

## Introduction

Important Information .....	<i>ii</i>
Serial Number Information .....	<i>ii</i>
Serial Number Legend .....	<i>iii</i>

---

## Section 1

### Safety Rules

General Safety Rules .....	<i>iv</i>
----------------------------	-----------

---

## Section 2

### Rev

### Specifications

A	SLA-5 .....	2 - 1
	SLA-10 .....	2 - 1
	SLA-15 .....	2 - 1
	SLA-20 .....	2 - 1
	SLA-25 .....	2 - 1
	SAE and Metric Fasteners Torque Charts .....	2 - 3

---

## Section 3

### Rev

### Scheduled Maintenance Procedures

	Introduction .....	3 - 1
	Pre-delivery Preparation Report .....	3 - 3
	Maintenance Inspection Report .....	3 - 5
A	<b>Checklist A Procedures</b>	
	A-1 Inspect the Manual and Decals .....	3 - 6
	A-2 Perform Pre-operation Inspection .....	3 - 7
	A-3 Perform Function Tests .....	3 - 7
A	<b>Checklist B Procedures</b>	
	B-1 Inspect all Welds .....	3 - 8
	B-2 Clean the Columns .....	3 - 8
	B-3 Check the Winch Operation .....	3 - 9
	B-4 Inspect the Carriage Hold-down Bar .....	3 - 9
	B-5 Inspect and Lubricate the Winch .....	3 - 10

---

 TABLE OF CONTENTS
 

---

<b>Section 3</b>	<b>Rev</b>	<b>Scheduled Maintenance Procedures, continued</b>	
	A	<b>Checklist C Procedures</b>	
		C-1 Inspect the Mast Assembly for Wear .....	3 - 11
		C-2 Inspect the Safety Brake System (if equipped) .....	3 - 12
		C-3 Replace the Winch Friction Discs .....	3 - 13
		C-4 Inspect the Cable and Cable Pulleys .....	3 - 14
		C-5 Lubricate the Casters Wheels .....	3 - 15
		C-6 Inspected the Painted Surfaces .....	3 - 15
<hr/>			
<b>Section 4</b>	<b>Rev</b>	<b>Troubleshooting Flow Charts</b>	
		Introduction .....	4 - 1
	A	Chart 1 : Mast Will Not Sequence Properly .....	4 - 2
	A	Chart 2 : Carriage Will Not Raise, Bur Winch Will Operate .....	4 - 3
	A	Chart 2 : Winch Will Not Operate .....	4 - 4
<hr/>			
<b>Section 5</b>	<b>Rev</b>	<b>Repair Procedures</b>	
		Introduction .....	5 - 1
	A	1 - 1 Base .....	5 - 2
	A	2 - 1 Mast Assembly .....	5 - 3
	A	2 - 2 Lifting Cable .....	5 - 7
	A	2 - 3 Lifting Pulley .....	5 - 8
	A	3 - 1 One-speed Winch .....	5 - 10
	A	3 - 2 Two-speed Winch .....	5 - 14

# Specifications

REV A

<b>Model</b>	<b>SLA-5</b>	<b>SLA-10</b>	<b>SLA-15</b>	<b>SLA-20</b>	<b>SLA-25</b>
Height - Stowed	78.5 in 2 m	78.5 in 2 m	78.5 in 2 m	78.5 in 2 m	78.5 in 2 m
Width Standard Base	31.5 in 80 cm	31.5 in 80 cm	31.5 in 80 cm	31.5 in 80 cm	31.5 in 80 cm
Width - stabilizers lowered Standard Base	78.63 in 2 m	78.63 in 2 m	78.63 in 2 m	78.63 in 2 m	78.63 in 2 m
Width - Minimum Straddle Base	31.5 in 80 cm	31.5 in 80 cm	31.5 in 80 cm	NA	NA
Width - Maximum Straddle Base	58 in 1.5 m	58 in 1.5 m	58 in 1.5 m	NA	NA
Length - Stowed	29 in 74 cm	29 in 74 cm	29 in 74 cm	29 in 74 cm	31 in 79 cm
Length - Operating	59.5 in 1.5 m	59.5 in 1.5 m	74 in 188 cm	82 in 208 cm	82 in 208 cm
Ground Clearance	2 in 5.1 cm	2 in 5.1 cm	2 in 5.1 cm	2 in 5.1 cm	2 in 5.1 cm
Load Capacity at 18 inch / 46 cm load center	1000 lbs 454 kg	1000 lbs 454 kg	800 lbs 363 kg	800 lbs 363 kg	650 lbs 295 kg
Net Weight - Standard Base	215 lbs 97.5 kg	260 lbs 117.9 kg	333 lbs 151 kg	405 lbs 183.7 kg	450 lbs 204.1 kg
Net Weight - Straddle Base	258 lbs 117.0 kg	303 lbs 137.4 kg	360 lbs 163.3 kg	NA	NA
<b>Load Handling Attachments</b>	<b>Length</b>	<b>Width</b>	<b>Depth</b>	<b>Net Weight</b>	
Standard Forks	27.5 in 70 cm	23.5 in 60 cm	2.5 in 6.4 cm	39 lbs 17.7 kg	
Adjustable Forks	27.5 in 70 cm	11.5 in to 30 in 29 cm to 76 cm	2.5 in 6.4 cm	52.5 lbs 23.8 kg	
Flat Forks	32 in 81.3 cm	16 in to 31 in 41 cm to 79 cm	1.5 in 3.8 cm	80 lbs 36 kg	
Boom	44 in 112 cm	1.5 in 4 cm	6.5 in 16.5 cm	40 lbs 18 kg	
Vertical Barrel Stacker	21 in 53 cm	29 in 74 cm	NA	50.5 lbs 22.9 kg	
Rotating Barrel Handler	29 in 74 cm	31 in 79 cm	NA	90 lbs 40.8 kg	
Pipe Cradle	27.5 in 70 cm	24.5 in 63 cm	6 in 15.2 cm	10 lbs 4.5 kg	
Load Platform	27.5 in 70 cm	23.5 in 60 cm	2.5 in 6.4 cm	31.5 lbs 14.3 kg	
Fork extensions (each)	30 in 76 cm	2 in 5 cm	3 in 7.6 cm	4.5 lbs 2 kg	



## SPECIFICATIONS

REV A



Dimensions - Operating		SLA-5	SLA-10	SLA-15	SLA-20	SLA-25
Standard Forks	Forks Down	4 ft 10.5 in 1.5 m	9 ft 9 in 3 m	14 ft 7.5 in 4.5 m	19 ft 6 in 5.9 m	24 ft 4 in 7.4 m
	Forks Up	6 ft 7 in 2 m	11 ft 5.5 in 3.5 m	16 ft 4 in 5 m	21 ft 2.5 in 6.5 m	26 ft .5 in 7.9 m
Adjustable Forks	Forks Down	4 ft 10.5 in 1.5 m	9 ft 9 in 3 m	14 ft 7.5 in 4.5 m	19 ft 6 in 6 m	24 ft 4 in 7.4 m
	Forks Up	6 ft 7 in 2 m	11 ft 5.5 in 3.5 m	16 ft 4 in 5 m	21 ft 2.5 in 6.5 m	26 ft .5 in 7.9 m
Flat Forks		4 ft 10.5 in 1.5 m	9 ft 9 in 3 m	14 ft 7.5 in 4.5 m	NA	NA
Boom		5 ft 10.5 in 1.8 m	10 ft 9 in 3.3 m	15 ft 7.5 in 4.8 m	20 ft 6 in 6.2 m	24 ft 4 in 7.4 m
Note: measured from ground to bottom of shackle						
Vertical Barrel Stacker	30 gallon	4 ft 1.2 m	8 ft 10 in 2.7 m	13 ft 9 in 4.2 m	NA	NA
	55 gallon	3 ft 10 in 1.2 m	8 ft 8 in 2.6 m	13 ft 7 in 4.1 m		
Note: measured from ground to bottom of barrel						
Rotating Barrel Handler						
	55 gallon	3 ft 10 in 1.2 m	8 ft 8 in 2.6 m	13 ft 7 in 4.1 m	NA	NA
	30 gallon	3 ft 10 in 1.2 m	8 ft 8 in 2.6 m	13 ft 7 in 4.1 m	NA	NA
Note: measured from ground to bottom of barrel						
Load Platform	forks down	4 ft 10.5 in 1.5 m	9 ft 9 in 3 m	14 ft 7.5 in 4.5 m	19 ft 6 in 6 m	24 ft 4 in 7.4 m
	forks up	6 ft 7 in 2 m	11 ft 5.5 in 3.5 m	16 ft 4 in 5 m	21 ft 2.5 in 6.5 m	26 ft .5 in 7.9 m
Note: can be used with standard forks and adjustable forks only						
Pipe Cradle Option: handles round objects up to 30 in / 76 cm in diameter						
Note: Can be used with standard forks and adjustable forks only (see above for working heights)						
Non-marking Fork Option						
Note: Can be used with standard forks and adjustable forks only (see above for working heights)						
Fork Extension Option: adds 6.25 to 25 inches / 15 to 64 cm of length to forks						
Note: can be used with standard forks and adjustable forks only (see above for working heights)						
Airborne Noise Emissions by Machinery		85 dB	85 dB	85 dB	85 dB	85 dB
Maximum sound level at normal operating workstations (A-weighted)						





**Continuous improvement of our products is a Genie policy. Product specifications are subject to change without notice.**



REV A

SPECIFICATIONS

<b>SAE FASTENER TORQUE CHART</b>											
• This chart is to be used as a guide only unless noted elsewhere in this manual •											
SIZE	THREAD	Grade 5 				Grade 8 				A574 High Strength Black Oxide Bolts	
		LUBED		DRY		LUBED		DRY		LUBED	
		in-lbs	Nm	in-lbs	Nm	in-lbs	Nm	in-lbs	Nm	in-lbs	Nm
1/4	20	80	9	100	11.3	110	12.4	140	15.8	130	14.7
	28	90	10.1	120	13.5	120	13.5	160	18	140	15.8
		LUBED		DRY		LUBED		DRY		LUBED	
		ft-lbs	Nm	ft-lbs	Nm	ft-lbs	Nm	ft-lbs	Nm	ft-lbs	Nm
5/16	18	13	17.6	17	23	18	24	25	33.9	21	28.4
	24	14	19	19	25.7	20	27.1	27	36.6	24	32.5
3/8	16	23	31.2	31	42	33	44.7	44	59.6	38	51.5
	24	26	35.2	35	47.4	37	50.1	49	66.4	43	58.3
7/16	14	37	50.1	49	66.4	50	67.8	70	94.7	61	82.7
	20	41	55.5	55	74.5	60	81.3	80	108.4	68	92.1
1/2	13	57	77.3	75	101.6	80	108.4	110	149	93	126
	20	64	86.7	85	115	90	122	120	162	105	142
9/16	12	80	108.4	110	149	120	162	150	203	130	176
	18	90	122	120	162	130	176	170	230	140	189
5/8	11	110	149	150	203	160	217	210	284	180	244
	18	130	176	170	230	180	244	240	325	200	271
3/4	10	200	271	270	366	280	379	380	515	320	433
	16	220	298	300	406	310	420	420	569	350	474
7/8	9	320	433	430	583	450	610	610	827	510	691
	14	350	474	470	637	500	678	670	908	560	759
1	8	480	650	640	867	680	922	910	1233	770	1044
	12	530	718	710	962	750	1016	990	1342	840	1139
1 1/8	7	590	800	790	1071	970	1315	1290	1749	1090	1477
	12	670	908	890	1206	1080	1464	1440	1952	1220	1654
1 1/4	7	840	1138	1120	1518	1360	1844	1820	2467	1530	2074
	12	930	1260	1240	1681	1510	2047	2010	2725	1700	2304
1 1/2	6	1460	1979	1950	2643	2370	3213	3160	4284	2670	3620
	12	1640	2223	2190	2969	2670	3620	3560	4826	3000	4067

<b>METRIC FASTENER TORQUE CHART</b>																
• This chart is to be used as a guide only unless noted elsewhere in this manual •																
Size (mm)	Class 4.6 				Class 8.8 				Class 10.9 				Class 12.9 			
	LUBED		DRY		LUBED		DRY		LUBED		DRY		LUBED		DRY	
	in-lbs	Nm	in-lbs	Nm	in-lbs	Nm	in-lbs	Nm	in-lbs	Nm	in-lbs	Nm	in-lbs	Nm	in-lbs	Nm
5	16	1.8	21	2.4	41	4.63	54	6.18	58	6.63	78	8.84	68	7.75	91	10.3
6	19	3.05	36	4.07	69	7.87	93	10.5	100	11.3	132	15	116	13.2	155	17.6
7	45	5.12	60	6.83	116	13.2	155	17.6	167	18.9	223	25.2	1.95	22.1	260	29.4
	LUBED		DRY		LUBED		DRY		LUBED		DRY		LUBED		DRY	
	ft-lbs	Nm	ft-lbs	Nm	ft-lbs	Nm	ft-lbs	Nm	ft-lbs	Nm	ft-lbs	Nm	ft-lbs	Nm	ft-lbs	Nm
8	5.4	7.41	7.2	9.88	14	19.1	18.8	25.5	20.1	27.3	26.9	36.5	23.6	32	31.4	42.6
10	10.8	14.7	14.4	19.6	27.9	37.8	37.2	50.5	39.9	54.1	53.2	72.2	46.7	63.3	62.3	84.4
12	18.9	25.6	25.1	34.1	48.6	66	64.9	88	69.7	94.5	92.2	125	81	110	108	147
14	30.1	40.8	40	54.3	77.4	105	103	140	110	150	147	200	129	175	172	234
16	46.9	63.6	62.5	84.8	125	170	166	226	173	235	230	313	202	274	269	365
18	64.5	87.5	86.2	117	171	233	229	311	238	323	317	430	278	377	371	503
20	91	124	121	165	243	330	325	441	337	458	450	610	394	535	525	713
22	124	169	166	225	331	450	442	600	458	622	612	830	536	727	715	970
24	157	214	210	285	420	570	562	762	583	791	778	1055	682	925	909	1233



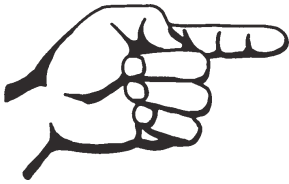

This page intentionally left blank.

# Scheduled Maintenance Procedures



## Observe and Obey:

- ☑ Maintenance inspections shall be completed by a person trained and qualified on the maintenance of this machine.
- ☑ Scheduled maintenance inspections shall be completed daily, quarterly, semi-annually, annually and every 2 years as specified on the *Maintenance Inspection Report*.

**▲WARNING** Failure to perform each procedure as presented and scheduled could result in death, serious injury or substantial damage.

- ☑ Immediately tag and remove from service a damaged or malfunctioning machine.
- ☑ Repair any machine damage or malfunction before operating the machine.
- ☑ Use only Genie approved replacement parts.
- ☑ Machines that have been out of service for a period longer than 3 months must complete the quarterly inspection.
- ☑ Unless otherwise specified, perform each procedure with the machine in the following configuration:
  - Machine positioned on a firm, level surface
  - Carriage fully lowered
  - Casters locked
  - Load handling attachment installed

## About This Section

This section contains detailed procedures for each scheduled maintenance inspection.

Each procedure includes a description, safety warnings and step-by-step instructions.

### Symbols Legend



Safety alert symbol—used to alert personnel to potential personal injury hazards. Obey all safety messages that follow this symbol to avoid possible injury or death.



Indicates an imminently hazardous situation which, if not avoided, will result in death or serious injury.



Indicates a potentially hazardous situation which, if not avoided, could result in death or serious injury.



Indicates a potentially hazardous situation which, if not avoided, may cause minor or moderate injury.



Indicates a potentially hazardous situation which, if not avoided, may result in property damage.

- ⊙ Indicates that a specific result is expected after performing a series of steps.
- ⊗ Indicates that an incorrect result has occurred after performing a series of steps.

## SCHEDULED MAINTENANCE PROCEDURES

### Maintenance Symbols Legend

Note: The following symbols have been used in this manual to help communicate the intent of the instructions. When one or more of the symbols appear at the beginning of a maintenance procedure, it conveys the meaning below.



Indicates that tools will be required to perform this procedure.



Indicates that new parts will be required to perform this procedure.



Indicates that dealer service will be required to perform this procedure.

### Pre-delivery Preparation Report

The pre-delivery preparation report contains checklists for each type of scheduled inspection.

Make copies of the *Pre-delivery Preparation Report* to use for each inspection. Store completed forms as required.

### Maintenance Schedule

There are three types of maintenance inspections that must be performed according to a schedule—daily, quarterly and annual. The *Scheduled Maintenance Procedures Section* and the *Maintenance Inspection Report* have been divided into three subsections—A, B and C. Use the following chart to determine which group(s) of procedures are required to perform a scheduled inspection.

Inspection	Checklist
Daily or every 8 hours	A
Quarterly or every 250 hours	A + B
Annual or every 1000 hours	A + B + C

### Maintenance Inspection Report

The maintenance inspection report contains checklists for each type of scheduled inspection.

Make copies of the *Maintenance Inspection Report* to use for each inspection. Maintain completed forms for a minimum of 4 years or in compliance with your employer, jobsite and governmental regulations and requirements.

# Pre-Delivery Preparation

## Fundamentals

It is the responsibility of the dealer to perform the Pre-delivery Preparation.

The Pre-delivery Preparation is performed prior to each delivery. The inspection is designed to discover if anything is apparently wrong with a machine before it is put into service.

A damaged or modified machine must never be used. If damage or any variation from factory delivered condition is discovered, the machine must be tagged and removed from service.

Repairs to the machine may only be made by a qualified service technician, according to the manufacturer's specifications.

Scheduled maintenance inspections shall be performed by qualified service technicians, according to the manufacturer's specifications and the requirements listed in the responsibilities manual.

## Instructions

Use the operator's manual on your machine.

The Pre-delivery Preparation consists of completing the Pre-operation Inspection, the Maintenance items and the Function Tests.

Use this form to record the results. Place a check in the appropriate box after each part is completed. Follow the instructions in the operator's manual.

If any inspection receives an N, remove the machine from service, repair and re-inspect it. After repair, place a check in the R box.

### Legend

Y = yes, completed

N = no, unable to complete

R = repaired

### Comments

Pre-Delivery Preparation	Y	N	R
Pre-operation inspection completed			
Maintenance items completed			
Function tests completed			

Model

Serial number

Date

Machine owner

Inspected by (print)

Inspector signature

Inspector title

Inspector company



**Genie Industries USA**  
18340 NE 76th Street  
PO Box 97030  
Redmond, WA 98073-9730  
(425) 881-1800

**Genie UK**  
The Maltings, Wharf Road  
Grantham, Lincolnshire  
NG31-6BH England  
(44) 1476-584333

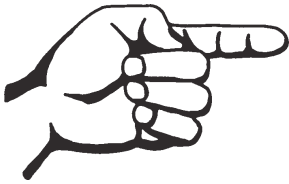

This page intentionally left blank.

# Maintenance Inspection Report

REV A

<b>Model</b>
<b>Serial number</b>
<b>Date</b>
<b>Machine owner</b>
<b>Inspected by (print)</b>
<b>Inspector signature</b>
<b>Inspector title</b>
<b>Inspector company</b>

Checklist A - Rev A		Y	N	R
A-1	Manuals and decals			
A-1	Pre-operation inspection			
A-2	Function tests			

Checklist B - Rev A		Y	N	R
B-1	Welds			
B-2	Clean columns			
B-3	Winch operation			
B-4	Carriage hold-down bar			
B-5	Inspect and lubricate winch			

Checklist C - Rev A		Y	N	R
C-1	Mast assembly wear			
C-2	Safety brake system (if equipped)			
C-3	Replace winch friction disks			
C-4	Inspect cable and pulleys			
C-5	Lubricate the casters and wheels			
C-6	Painted surfaces			

**Instructions**

- Make copies of this report to use for each inspection.
- Select the appropriate checklist(s) for the type of inspection to be performed.

	<b>Daily or 8 hour Inspection:</b>	<b>A</b>
	<b>Quarterly or 250 hour Inspection:</b>	<b>A+B</b>
	<b>Annual or 1000 hour Inspection:</b>	<b>A+B+C</b>

**Comments**

- Place a check in the appropriate box after each inspection procedure is completed.
- Use the step-by-step procedures in this section to learn how to perform these inspections.
- If any inspection receives an "N", tag and remove the machine from service, repair and re-inspect it. After repair, place a check in the "R" box.

**Legend**

- Y = yes, acceptable
- N = no, remove from service
- R = repaired



# Checklist A Procedures

REV A

## A-1 Inspect the Manuals and Decals

Genie specifications require that this procedure be performed every 8 hours or daily, whichever comes first.

Maintaining the operator's and safety manuals in good condition is essential to safe machine operation. Manuals are included with each machine and should be stored in the container provided in the platform. An illegible or missing manual will not provide safety and operational information necessary for a safe operating condition.

In addition, maintaining all of the safety and instructional decals in good condition is mandatory for safe machine operation. Decals alert operators and personnel to the many possible hazards associated with using this machine. They also provide users with operation and maintenance information. An illegible decal will fail to alert personnel of a procedure or hazard and could result in unsafe operating conditions.

- 1 Check to make sure that the operator's and safety manuals are present and complete in the storage container on the platform.
  - 2 Examine the pages of each manual to be sure that they are legible and in good condition.
- ⦿ Result: The operator's manual is appropriate for the machine and all manuals are legible and in good condition.
  - ✗ Result: The operator's manual is not appropriate for the machine or all manuals are not in good condition or is illegible. Remove the machine from service until the manual is replaced.

- 3 Open the operator's manual to the decals inspection section. Carefully and thoroughly inspect all decals on the machine for legibility and damage.
- ⦿ Result: The machine is equipped with all required decals, and all decals are legible and in good condition.
  - ✗ Result: The machine is not equipped with all required decals, or one or more decals are illegible or in poor condition. Remove the machine from service until the decals are replaced.
- 4 Always return the manuals to the storage container after use.

Note: Contact your authorized Genie distributor or Genie Industries if replacement manuals or decals are needed.

REV A

CHECKLIST A PROCEDURES

## **A-2 Perform Pre-operation Inspection**

Genie specifications require that this procedure be performed every 8 hours or daily, whichever comes first.

Completing a Pre-operation Inspection is essential to safe machine operation. The Pre-operation Inspection is a visual inspection performed by the operator prior to each work shift. The inspection is designed to discover if anything is apparently wrong with a machine before the operator performs the function tests. The Pre-operation Inspection also serves to determine if routine maintenance procedures are required.

Complete information to perform this procedure is available in the appropriate operator's manual. Refer to the Operator's Manual on your machine.

## **A-3 Perform Function Tests**

Genie specifications require that this procedure be performed every 8 hours or daily, whichever comes first.

Completing the function tests is essential to safe machine operation. Function tests are designed to discover any malfunctions before the machine is put into service. A malfunctioning machine must never be used. If malfunctions are discovered, the machine must be tagged and removed from service.

Complete information to perform this procedure is available in the appropriate operator's manual. Refer to the Operator's Manual on your machine.

# Checklist B Procedures

REV A

## B-1 Inspect All Welds

Genie specifications require that this procedure be performed every 250 hours or quarterly, whichever comes first.

Weld inspections are essential to safe machine operation and good machine performance. Failure to locate and repair damage may result in an unsafe operating condition.

- 1 Visually inspect the welds in the following locations:
  - Winch mounting plate
  - Loading wheels/steer handle
  - Base
  - Legs and stabilizers
  - Load handling attachment(s)

## B-2 Clean the Columns



Genie specifications require that this procedure be performed every 250 hours or quarterly, whichever comes first.

Clean columns are essential to good machine performance and safe operation. Extremely dirty conditions may require that the columns be cleaned more often.

- 1 Raise all columns to full height.
- 2 Visually inspect the inner and outer channels of the columns for debris or foreign material. If necessary, use a mild cleaning solvent to clean the columns.

**▲WARNING** Bodily injury hazard. This procedure will require the use of additional access equipment. Do not place ladders or scaffold on or against any part of the machine. Performing this procedure without the proper skills and tools could result in death or serious injury. Dealer service is strongly recommended.

REV A

CHECKLIST B PROCEDURES

### **B-3**

## **Check the Winch Operation**

Genie specifications require that this procedure be performed every 250 hours or quarterly, whichever comes first.

Detection of damage to the winch is essential to safe machine operation. An unsafe working condition exists if the winch is damaged or not operating correctly. A daily check of the winch operation allows the inspector to identify changes in the operating condition of the winch that might indicate damage.

- 1 Visually inspect all the winch components for damage.
- 2 Raise the carriage through a partial cycle and release the winch handles.
- ⊙ Result: The winch should operate smoothly, free of hesitation or binding. The load should not lower when the handles are released.
- 3 Fully lower the carriage.
- ⊙ Result: The winch should operate smoothly, free of hesitation or binding.

### **B-4**

## **Inspect the Carriage Hold-down Bar**

Genie specifications require that this procedure be performed every 250 hours or quarterly, whichever comes first.

Detection of damage to the column hold down system is essential for safe machine operation. An unsafe working condition exists if the system is damaged and does not operate properly.

- 1 Using proper lifting techniques, lay the machine back against a sawhorse or other suitable support.
- 2 Visually inspect the carriage hold-down bar for damage
- 3 Check the carriage hold-down bar for smooth operation.

## CHECKLIST B PROCEDURES

REV A

## B-5 Inspect and Lubricate the Winch



Genie specifications require that this procedure be performed every 250 hours or quarterly, whichever comes first.

Maintaining the winch is essential to good machine performance and safe operation. An unsafe working condition exists if the winch has excessive wear and/or does not operate smoothly, free of hesitation and binding.

- 1 Carefully lubricate the following areas with automotive grease:
  - Cable drum gear
  - Teeth on the pinion gear that mesh with the cable drum gear
  - Threads on the pinion shaft, under the pinion gear
  - **Models with Two-speed winch:** The teeth on the slow and the fast speed gears where they mesh together

Note: Do not apply grease to brake friction disks or ratchet gear.

- 2 Carefully lubricate both pivot points on each ratchet pawl with 30W oil.

- 3 Measure each friction disk for wear. Replace the friction disk if it measures less than specification.

---

### Friction disk specification

---

Thickness, minimum	1/16 inch 1.5 mm
--------------------	---------------------

---

- 4 Measure both shaft bushings for wear. Replace the bushings if the wall thickness measurements are less than specification.

---

### Pinion shaft bushing specification

---

Wall thickness, minimum	1/8 inch 3.1 mm
-------------------------	--------------------

---

- 5 Lubricate the surface of the frame drum spacer with a thin layer of lithium grease. Tighten the drum bolt to 20 ft-lbs / 27 Nm. Do not overtighten.

# Checklist C Procedures

REV A

## C-1 Inspect the Mast Assembly for Wear



Genie specifications require that this procedure be performed every 1000 hours or annually, whichever comes first.

Detection of excessive or unusual wear in the mast assembly is essential for safe machine operation. An unsafe working condition exists if the mast assembly has excessive wear and/or does not operate smoothly, free of hesitation and binding.

- 1 Attach a lifting strap from an overhead crane or similar lifting device to the lifting point on the top of the mast. Rotate the carriage hold-down bar over the carriage and operate the winch to apply tension to the lifting cable.
- 2 Lift the machine slightly with the overhead crane and guide it onto a suitable structure capable of supporting it.

**WARNING** Crushing hazard. The machine will fall if not properly supported by the overhead crane.

- 3 Lower the top of the mast onto the suitable structure.
- 4 Attach a lifting strap from an overhead crane to the base of the machine.
- 5 Lift the base with the overhead crane, until the mast is level and place another suitable structure under the mast.

- 6 Lower the base end of the machine.
- 7 Rotate the mast assembly until the carriage is on top.



- 8 Visually inspect the top of each column for clearance between the roller wheel and the adjacent column surface.
  - ⊙ Result: There should be a gap of less than 0.062 inch / 1.57 mm between the roller wheel and the column.

Note: If the mast inspection results in a measurement that is not within specification, See Repair procedure 2-1, *How to Disassemble the Mast Assembly*.

- 9 Visually inspect the bottom of each column for clearance between the roller wheel and the adjacent column surface.
  - ⊙ Result: There should be a gap of less than 0.062 inch / 1.57 mm between the roller wheel and the column.

Note: If the mast inspection results in a measurement that is not within specification, refer to Repair procedure 2-1, *How to Disassemble the Mast Assembly*.

- 10 Grasp the bottom of the carriage and lift it approximately 12 inches / 30.5 cm, then release the carriage.
  - ⊙ Result: The carriage should stop within 5 to 8 inches / 12.7 to 20.3 cm and the safety brake should engage.

**CAUTION** Crushing hazard. Do not stand directly under the carriage or load handling attachment.

## CHECKLIST C PROCEDURES

REV A

## C-2 Inspect the Safety Brake System (if equipped)



Genie specifications require that this procedure be performed every 1000 hours or annually, whichever comes first.

Detection of damage or a faulty safety brake system is essential for safe machine operation. An unsafe working condition exists if the system is damaged or faulty and does not allow the mast to sequence properly, free of hesitation and binding.

**AWARNING** Bodily injury hazard. This procedure requires specific repair skills and a suitable workshop. Attempting this procedure without these skills could result in death or serious injury or significant component damage. Dealer service is strongly recommended.

**CAUTION** Bodily injury hazard. Beware of sharp edges. Wear protective gloves when performing this procedure.

- 1 Fasten a load handling attachment to the carriage (use the forks or the boom if possible). Do not place any weight on the load handling attachment.
- 2 Raise the carriage until it is half way up the front column

- 3 Grasp the bottom carriage and lift it approximately 12 inches / 30 cm, then release the carriage.

- ⊙ Result: The carriage should stop within 5 to 8 inches / 12.7 to 20.3 cm and the safety brake should engage.

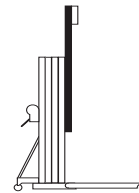

**CAUTION** Crushing hazard. Do not stand directly under the carriage or load handling attachment.

- 4 Raise the carriage approximately 12 inches / 30.5 cm to disengage the safety brake.
  - 5 Operate the winch until the front column is half way up the adjacent column.
  - 6 Grasp the bottom of the front column and lift it approximately 5 inches / 12 cm, then release the column.
- ⊙ Result: The carriage should stop within 5 to 8 inches / 12 to 20 cm and the safety brake should engage.

**CAUTION** Crushing hazard. Do not stand directly under the columns or load handling attachment.

REV A

CHECKLIST C PROCEDURES

- 7 Raise the front column approximately 12 inches / 30 cm to disengage the safety brake.
  - 8 Operate the winch until the front column is fully raised and the second column is half way up the adjacent column.
  - 9 Grasp the bottom side of the next column and lift it approximately 12 inches / 30 cm, then release the column.
- ⊙ Result: The carriage should stop within 5 to 8 inches / 12 to 20 cm and the safety brake should engage.

**CAUTION** Crushing hazard. Do not stand directly under the columns or load handling attachment.

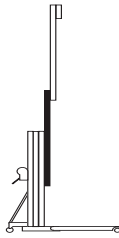

- 10 Repeat steps 7 through 9 to test all remaining columns.

Note: When disengaging the safety brake, it may be necessary to hold down the column behind the column to be disengaged.

Note: The number one column (column attached to the base) does not have a safety brake and will not need to be tested.

### C-3 Replace the Winch Friction Disks



Genie specifications require that this procedure be performed every 1000 hours or annually, whichever comes first.

Maintaining the winch is essential to good machine performance and safe operation. An unsafe working condition exists if the winch has excessive wear and/or does not operate smoothly, free of hesitation and binding.

- 1 Replace the winch friction disks. See Repair procedure 3-1 *How to Disassemble a One-speed Winch*, or 3-2, *How to Disassemble a Two-speed Winch*.

## CHECKLIST C PROCEDURES

REV A

## C-4 Inspect the Cable and Cable Pulleys

Genie specifications require that this procedure be performed every 1000 hours or annually, whichever comes first.

Detection of damage to cable or pulleys is essential for safe machine operation. An unsafe working condition exists if these components are damaged and do not operate smoothly. The inspection of this system allows the inspector to identify changes in the operating condition that might indicate damage.

Note: The mast must be disassembled during the annual inspection of the machine, otherwise the cable, cable pulleys and mast rollers are only partially visible for inspection.

- 1 Disassemble the mast assembly. Refer to Repair Procedures 2-1, *How to Disassemble the Mast Assembly*.
- 2 Visually inspect the cable and components for the following:
  - frayed or broken wire strands
  - kinks in the cable
  - corrosion
  - paint or foreign materials
  - split or cracked swagged end(s)
  - upper and lower mounting brackets are properly secured
  - no broken or damaged pulleys
  - no unusual or excessive pulley wear
  - no broken or damaged mast rollers
  - no unusual or excessive mast roller wear
- 3 Assemble the mast assembly. Refer to Repair Procedures 2-1, *How to Assemble the Mast Assembly*.

**CAUTION** Bodily injury hazard. Beware of sharp edges. Wear protective gloves when performing this procedure.

REV A

CHECKLIST C PROCEDURES

## C-5 Lubricate the Casters and Wheels



Genie specifications require that this procedure be performed every 1000 hours or annually, whichever comes first.

Regular application of lubrication to the Caster or Wheel is essential to good machine performance and service life. Extremely dirty conditions may require that the casters and wheels be inspected and lubricated more often.

- 1 Visually inspect each caster and wheel for cuts, cracks or unusual wear.
- 2 Move the machine on a flat smooth surface and check that the casters and wheels roll smoothly, free of hesitation and binding.
- 3 Pump grease into the caster or wheel until it can be seen coming out of the bearing gap.

---

### Grease Specification

---

Chevron Ultra-duty grease, EP NLGI 1 (lithium based) or equivalent

---

## C-6 Inspect the Painted Surfaces

Genie specifications require that this procedure be performed every 1000 hours or annually, whichever comes first.

Inspecting the painted surfaces of your machine is essential to safe operation and long machine life. An unsafe working condition exists if there is damage to painted surfaces that is not corrected.

- 1 Visually inspect all painted surfaces for the following conditions:
  - Blistering
  - Rust
  - Peeling
  - Fading
  - Corrosion

Note: Replace any component that is damaged.

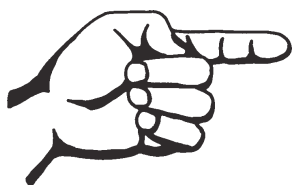

This page intentionally left blank.

# Troubleshooting Flow Charts



## Observe and Obey:

- ☑ Troubleshooting and repair procedures shall be completed by a person trained and qualified on the repair of this machine.
- ☑ Immediately tag and remove from service a damaged or malfunctioning machine.
- ☑ Repair any machine damage or malfunction before operating the machine.
- ☑ Be sure the capacities of sawhorses or other supports are sufficient to withstand machine weight. See Specifications section for specific weight.
- ☑ Be sure overhead cranes or other lifting devices are of ample capacity to handle machine weight. See Specification section for specific weight.

## Before Troubleshooting:

- ☑ Read, understand and obey the safety rules and operating instructions printed in the *Genie Superlift Advantage Operator's Manual*.
- ☑ Be sure that all necessary tools and test equipment are available and ready for use.
- ☑ Read each appropriate flow chart thoroughly. Attempting shortcuts may produce hazardous conditions.
- ☑ Be aware of the following hazards and follow generally accepted safe workshop practices.

**⚠ DANGER** Crushing hazard. When testing or replacing the primary component, always support the structure and secure it from movement.

Note: Perform all troubleshooting on a firm, level surface.

Note: Two people will be required to safely perform some troubleshooting procedures.

## About This Section

When a malfunction is discovered, the flow charts in this section will help a service professional pinpoint the cause of the problem. To use this section, basic hand tools are required.

### General Repair Process

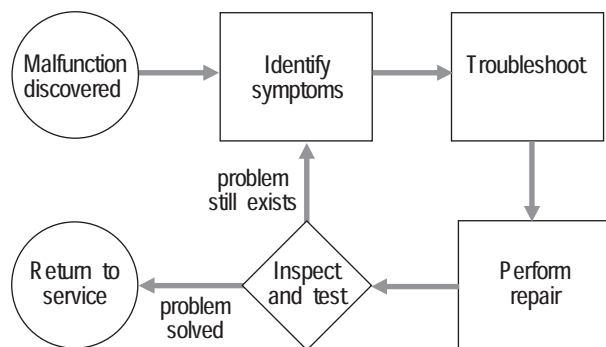

# Chart 1

REV A

## Mast Will Not Sequence Properly

Be sure safety brake (if equipped) is not engaged by fully raising and lowering all columns.

Improper sequencing of the mast columns may occur when the machine is at or near maximum capacity. If improper sequencing occurs, the columns may shift to their correct position during operation or when the load is removed. The forks will not change position if the columns shift position. The carriage should always raise first, and lower last.

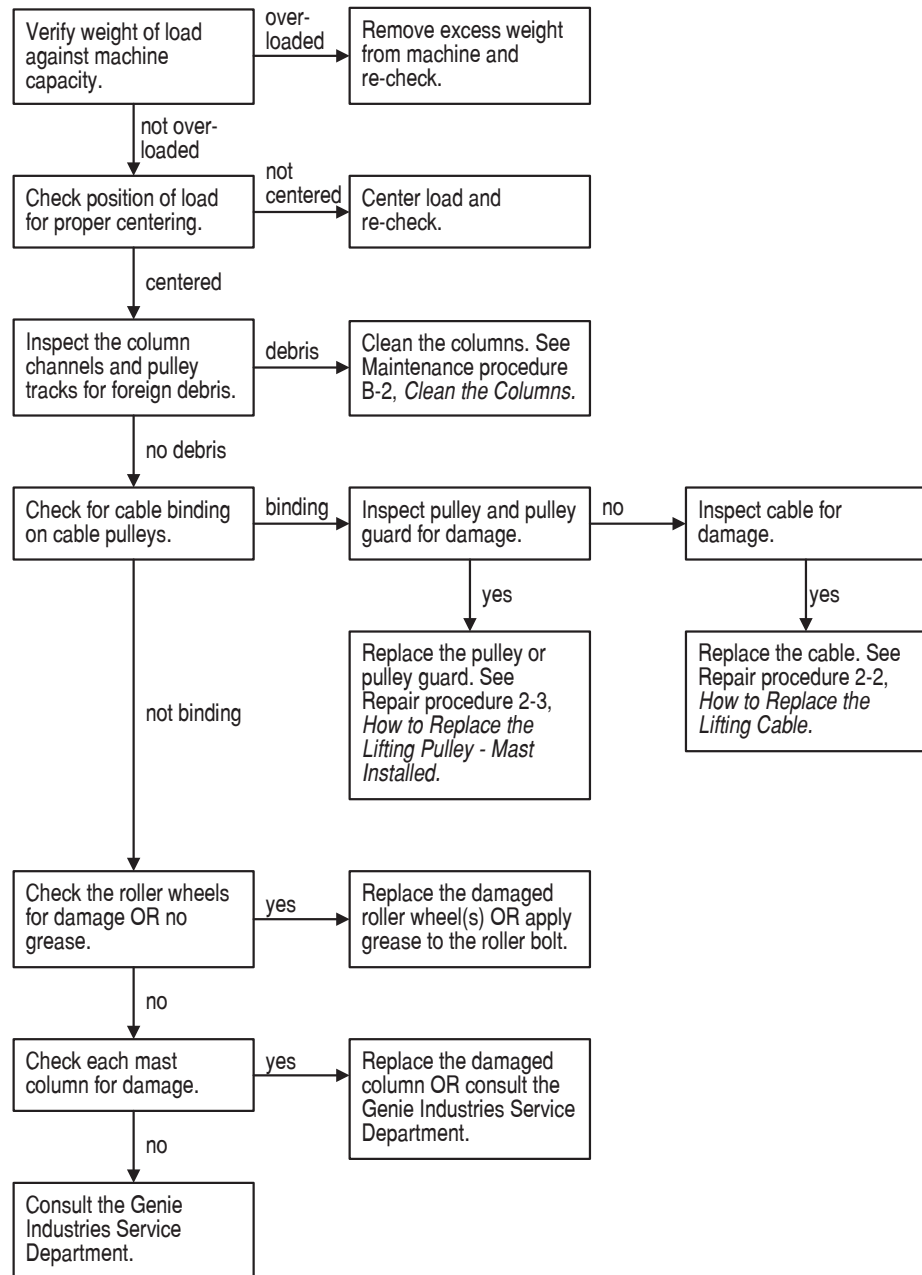

# Chart 2

REV A

## Carriage Will Not Raise, But Winch Will Operate

Be sure the carriage hold-down bar is not engaged.

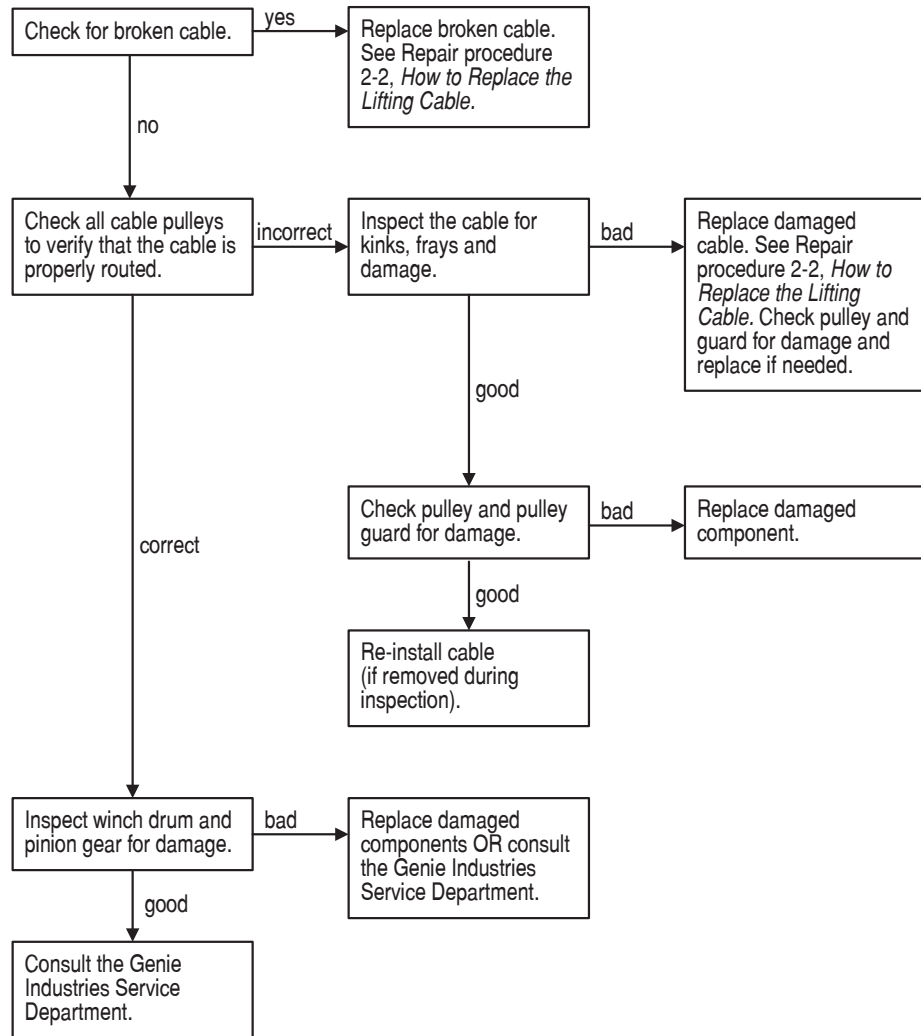

# Chart 3

REV A

## Winch Will Not Operate

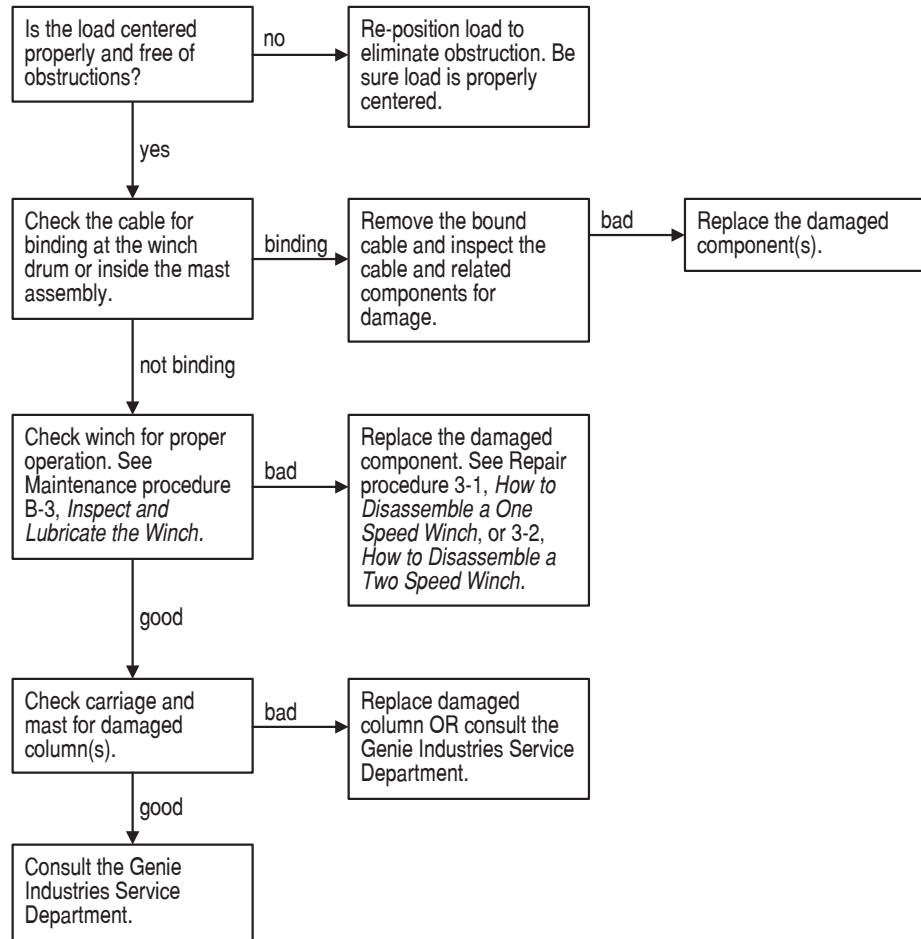

# Repair Procedures



## Observe and Obey:

- ☑ Repair procedures shall be completed by a person trained and qualified on the repair of this machine.
- ☑ Immediately tag and remove from service a damaged or malfunctioning machine.
- ☑ Repair any machine damage or malfunction before operating the machine.

## Before Repairs Start:

- ☑ Read, understand and obey the safety rules and operating instructions in the *Genie Superlift Advantage Operator's Manual*.
- ☑ Be sure that all necessary tools and parts are available and ready for use.
- ☑ Use only Genie approved replacement parts.
- ☑ Be sure the capacities of sawhorses or other supports are sufficient to withstand machine weight. See Specifications section for the machine weight.
- ☑ Be sure overhead cranes or other lifting devices are of ample capacity to handle machine weight. See Specifications section for specific weight.
- ☑ Read each procedure completely and adhere to the instructions. Attempting shortcuts may produce hazardous conditions.
- ☑ Unless otherwise specified, perform each procedure with the machine in the following configuration:
  - Machine positioned on a firm, level surface
  - Carriage fully lowered
  - Casters locked

## About This Section

Most of the procedures in this section should only be performed by a trained service professional in a suitably equipped workshop. Select the appropriate repair procedure after troubleshooting the problem. Perform disassembly procedures to the point where repairs can be completed. To re-assemble, perform the disassembly steps in reverse order.

### Symbols Legend



Safety alert symbol—used to alert personnel to potential personal injury hazards. Obey all safety messages that follow this symbol to avoid possible injury or death.

#### **⚠ DANGER**

Indicates an imminently hazardous situation which, if not avoided, will result in death or serious injury.

#### **⚠ WARNING**

Indicates a potentially hazardous situation which, if not avoided, could result in death or serious injury.

#### **⚠ CAUTION**

Indicates a potentially hazardous situation which, if not avoided, may cause minor or moderate injury.

#### **NOTICE**

Indicates a potentially hazardous situation which, if not avoided, may result in property damage.

- ⦿ Indicates that a specific result is expected after performing a series of steps.
- ⊗ Indicates that an incorrect result has occurred after performing a series of steps.

# Base Assembly

REV A

## 1-1 Base

### How to Remove the Base

- 1 Loosen the locking screw and retract the extendable legs (if equipped).
- 2 Fully lower the carriage.
- 3 Remove the load handling attachment from the machine.

#### Models with stabilizers:

- 4 Remove the mounting fasteners from the stabilizer mounting bracket on the back of the mast.
- 5 Remove the mounting fastener from each stabilizer at the base. Remove each stabilizer from the machine.

#### All Models:

- 6 Using proper lifting techniques, tilt the machine back and rest the loading wheels against a suitable structure capable of supporting it.

**CAUTION** Bodily injury hazard. Use proper lifting techniques when rolling the mast assembly over.



- 7 Remove the mounting fastener and retaining pin from each leg. Remove the legs from the machine.
- 8 Using proper lifting techniques, carefully tilt the machine to the upright position.

**CAUTION** Bodily injury hazard. Use proper lifting techniques when tilting the machine to the upright position.

- 9 Attach a lifting strap from an overhead crane to the lifting eye at the top of the number one mast column.
- 10 Position a suitable structure capable of supporting the machine on the carriage side of the mast.
- 11 Carefully lift the machine slightly with the overhead crane. While lowering it, guide the machine over onto a suitable structure capable of supporting it.

**CAUTION** Crushing hazard. The machine may become unbalanced and fall if not properly supported by the overhead crane.

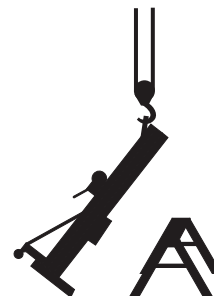

# Mast Assembly

REV A

- 12 Secure the top of the mast to the support.
- 13 Attach a lifting strap from an overhead crane to the base and lift the machine to a horizontal position. Slide a second suitable structure capable of supporting it under the mast, next to the base.

**⚠ WARNING** Crushing hazard. The machine could become unbalanced and fall if not properly supported by the overhead crane.

- 14 Remove the mounting fasteners from both mast braces at the base.
- 15 Remove the base mounting fasteners. Remove the base from the machine.

Note: When installing the base, be sure that the mast and the base are square.

## 2-1 Mast Assembly

### How to Disassemble the Mast Assembly

Note: Removal of the base is only necessary when the number one column is to be removed. See 1-1, *How to Remove the Base*.

- 1 Fully lower the carriage and remove the load handling attachment.
- 2 Remove the cable retaining fasteners from the winch drum. Remove all of the cable from the drum.
- 3 Lift the machine slightly with an overhead crane. While tilting backwards with the carriage facing up, guide the machine over onto a suitable structure.

**⚠ CAUTION** Bodily injury hazard. Use proper lifting techniques when lifting the mast assembly.

**⚠ CAUTION** Crushing hazard. The machine may become unbalanced and fall if not properly supported.

- 4 Remove the mounting fastener from the cable anchor at the top of the last column (carriage side).

## MAST ASSEMBLY

REV A

- 5 Remove the cable from the mast by pulling on the cable anchor end of the cable.

**CAUTION** Bodily injury hazard. Cables can fray. Always wear adequate hand protection when handling cable.

- 6 Slide the carriage up approximately 12 inches / 30 cm to expose the column stop mounting fastener, attached to the bottom end of the top column. Remove the fasteners and the column stop.
- 7 **Models with safety brake:** Insert a hex key wrench through the access holes in the carriage to release the safety brake. Position the hex key above the safety brake rollers. Slide the carriage away from the base while pulling back on the wrench.

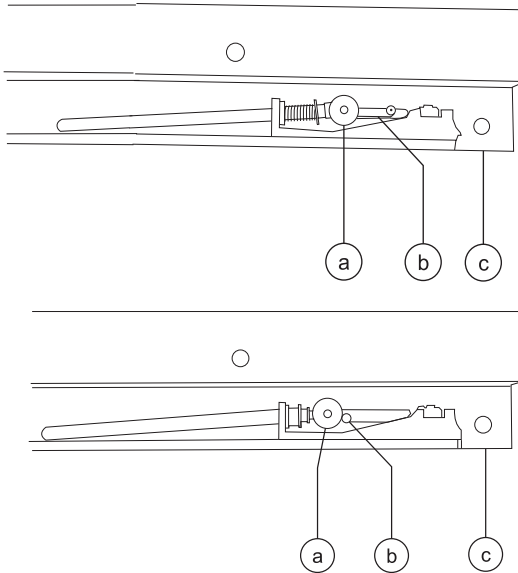

- a Brake roller  
b Brake release tool  
c Column or carriage

- 8 **Models with safety brake:** Remove the carriage by sliding it out the bottom of the mast toward the base while holding the safety brake rollers in the released position with the hex key wrench.

**Models without safety brake:** Remove the carriage by sliding it out the bottom of the mast toward the base.

- 9 Slide the column up approximately 12 inches / 30 cm to expose the column stop mounting fasteners attached to the bottom end of the top column. Remove the fasteners and the column stops.
- 10 **Models with safety brake:** Insert a hex key wrench through the access holes in the column up to release the safety brake. Position the hex key above the safety brake rollers. Slide the carriage away from the base while pulling back on the wrench.
- 11 **Models with safety brake:** Remove the column by sliding it out the bottom of the mast toward the base while holding the safety brake rollers in the released position with the hex key wrench.
- Models without safety brake:** Remove the column by sliding it out the bottom of the mast toward the base.
- 12 Repeat steps 10 through 12 for each remaining column.

REV A

MAST ASSEMBLY

## How to Release the Safety Brake When Servicing the Mast

The safety brake system can engage when the machine is tilted horizontally if the hold-down bar is not used. When the brake is engaged, the columns can extend but not retract. If the safety brake system engages while you are servicing the mast, use one of the following methods described below to release the brake.

**Method A:** This method allows you to release each column in sequence, starting at the carriage and removing columns one at a time. See 2-1, *How to Disassemble the Mast Assembly*.

**Method B:** This method allows you to release any column in the assembly regardless of its position, but requires a custom tool. The tool is a piece of  $\frac{1}{8}$  to  $\frac{5}{16}$  inch / 3.2 to 8 mm diameter stiff wire bent in an L shape with one end 1 inch / 25 mm long and the other end 16 inches / 41 cm long. The installation of a handle on the long end will make it easier to use. This tool is available from Genie Industries (Genie part number 33875).



Insert the tool from the bottom of the column into the safety brake access slot in the inner side wall of the column. Reach through the far upper end of the slot and position the short end of the tool above the safety brake rollers. Slide the carriage away from the base while pulling back on the tool.

## How to Assemble the Mast

- 1 Inspect all mast parts for wear and damage. Replace as necessary.
  - 2 Clean all columns and rollers.
  - 3 Clean all safety brake assemblies (if equipped).
  - 4 Position the number one column so that it is open-side up and level. If it is not attached to the base, secure the column to the supports.
  - 5 Install all column assembly components (removed during disassembly) except the column down stops. Apply a small amount of multi-purpose grease between the roller bolt head and the inside of the roller wheel.
  - 6 Slide the number two column into the number one from the bottom. Stop inserting the column when the top of the up stop or the safety brake assembly is even with the bottom edge of the number one column.
  - 7 Repeat steps 4 through 6 with all remaining columns. Do not install the carriage.
- Note: The cable is installed after all columns are together as an assembly.
- 8 Attach the swaged end of the cable to the cable anchor on the top of the front column.

## MAST ASSEMBLY

REV A

- 9 Feed the other end of the cable through the box section (web) of the carriage into the pulley, then push the cable through the pulley until it comes out the back side of the carriage.

**CAUTION** Bodily injury hazard. Cables can fray. Always wear adequate hand protection when handling cable.

Note: Refer to the figure below to identify the cable routing.

- 10 Insert the carriage into the bottom end of the top column. Hold the carriage in place and pull the cable up to the top of the column, leaving enough slack to feed the cable through the next pulley.
- 11 Push the cable through the exposed portion of the pulley at the top of the column until the cable reaches the pulley at the bottom of the column.
- 12 Remove the lower pulley assembly from the upper column.
- 13 Route the cable into and around the lower pulley.
- 14 Apply Loctite® removable thread sealant to the pulley mounting fastener and install the lower pulley into the column.
- 15 Push the cable between the two mast sections until it comes out the top of the column.
- 16 Repeat steps 11 through 15 with all remaining columns.
- 17 Slide all the columns forward, until you can install the column stops. Do not slide the columns forward any farther than necessary.
- 18 Install all the components removed during disassembly.

Note: Be sure that all fasteners have Loctite® removable thread sealant applied to the threads and that all fasteners have been securely tightened.

- 19 Attach the cable to the winch and be sure the cable is routed correctly.

- 20 Raise the machine to full height to release the safety brakes (if equipped) and verify proper operation.

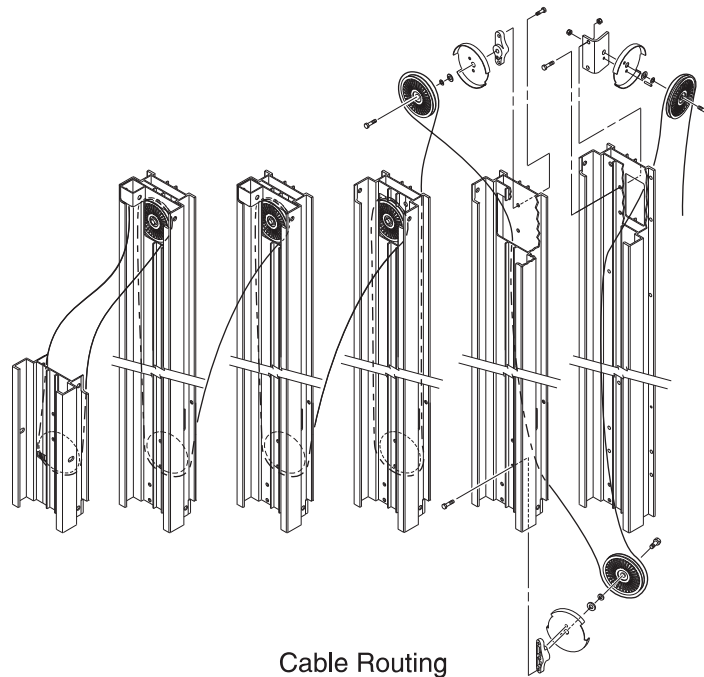

Cable Routing

REV A

MAST ASSEMBLY

## 2-2 Lifting Cable

### How to Replace the Lifting Cable

**CAUTION** Bodily injury hazard. Cables can fray. Always wear adequate hand protection when handling cable.

Note: All Genie replacement cables come with one pre-swaged end that terminates at the top of the last column and one taped end that terminates at the winch.

Note: For additional information, refer to instructional video, *Genie Superlift Cabling Procedure*. This video is available from Genie Industries (Genie part number 52701).

- 1 Fully lower the carriage.
- 2 Remove the retaining fasteners from the eyelet end of the cable at the mast anchor plate and cut the eyelet off below the copper sleeve.

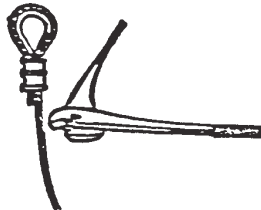

- 3 Remove the old cable from the winch drum.
- 4 Unwind the outer strands and trim them back  $\frac{1}{2}$  inch / 13 mm leaving the core longer. Repeat this process on the open end of the new cable.

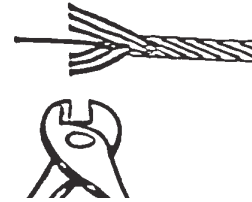

- 5 Using the optional cable threading tool (Genie part number 12402), insert even amounts of cable into each end of the tool. Securely tighten the set screws.

**CAUTION** Bodily injury hazard. This tool is intended for cable replacement only. Do not use as a load carrying cable splice.

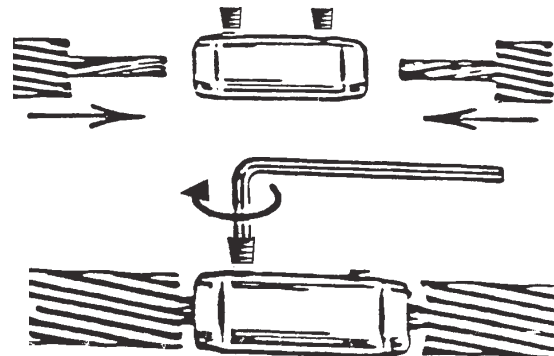

## MAST ASSEMBLY

REV A

- 6 Place a smooth layer of strapping tape over the joint section of the two cables and the tool.

Note: If the cable gets caught as you are pulling it through the columns and pulleys, avoid pulling too hard as you may break the connection between the two cables. Try pulling the cable back and forth until the cable pulls freely.



- 7 Pull on the old cable while feeding the new cable through the machine.
- 8 When the taped area appears at the winch, loosen the set screws and remove the old cable.
- 9 Attach the new cable to both the mast anchor and the winch drum.
- 10 Wind the new cable evenly onto the winch drum. Be sure there are at least four wraps of cable on the winch drum.
- 11 Fully raise and lower the carriage without a load to check for proper operation. The carriage should raise and lower smoothly.
- 12 Fully raise and lower the carriage again with a load and check for proper operation. The carriage should raise and lower smoothly.

**CAUTION** Do not use as a load carrying cable splice. This tool is intended for cable replacement only.

## 2-3 Lifting Pulley

### How to Replace a Lifting Pulley - Mast Installed

- 1 Fully lower the carriage.
- 2 Unwind approximately 1 to 2 feet / 30 to 60 cm of cable from the winch drum.
- 3 Tip the machine backwards and rest the top of the number one mast on a suitable structure capable of supporting it. Secure the top of the mast to the structure.
- 4 Attach an overhead crane to the base. Lift the machine to a horizontal position and slide a second structure under the mast next to the base.
- 5 If replacing an upper pulley, slide the column that is above the pulley to be replaced forward. If replacing a lower pulley, slide the column with the pulley to be replaced forward. Push the column forward approximately 6 inches / 15 cm to expose the lower column stop.
- 6 Remove the column stop mounting fasteners.
- 7 Slide the column backwards until the pulley that is to be replaced is exposed.
- 8 Remove the two mounting fasteners from the pulley mounting block. Remove the pulley assembly.
- 9 Remove the retaining fastener that attaches the pulley to the mounting block.

Note: Note the quantity and location of the shims and spacers before disassembling.

REV A

MAST ASSEMBLY

10 Remove the old pulley.

11 Install the cable onto the new pulley.

12 Apply Loctite® removable thread sealant to the pulley mounting fastener and install the fastener through the pulley and pulley guard into the pulley mounting block.

**WARNING** Crushing hazard. Failure to properly route the cable could result in a winch brake failure.

**NOTICE** Component damage hazard. Do not allow the cable to become twisted during installation or mast sequencing problems may occur.

Note: Be sure the cable guard is located over the retaining pin on the pulley mounting block. Be sure the pulley spins freely after reassembling the pulley assembly.

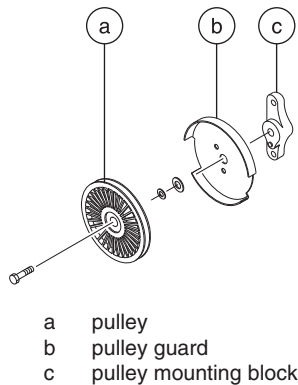

13 Apply Loctite® removable thread sealant to the fastener and install the pulley assembly onto the column.

14 Assemble the columns in reverse order of disassembly.

# Winches

REV A

## 3-1 One-speed Winch

### How to Disassemble a One-speed Winch

**CAUTION** Bodily injury hazard. Cables can fray. Always wear adequate hand protection when handling cable.

- 1 Fully lower the carriage.
- 2 Remove the cable retaining fastener from the winch drum. Remove the cable from the winch drum.
- 3 Remove both handle retaining fasteners. Remove the handles from the pinion shaft.
- 4 Remove the drum bolt and the drum bolt spacer. Remove the drum, drum gear cover and housing spacer from the winch.
- 5 Remove the two lock nuts from the pinion shaft by holding the opposite end of the shaft at the flattened portion of the threads.

**NOTICE** Component damage hazard. Be careful not to damage the threads while holding the pinion shaft.

- 6 Remove the retaining ring from the pinion shaft.

- 7 Slide the pinion shaft to the right and remove the pinion spacer, pinion plate, ratchet gear and friction disks. Turn the pinion gear counterclockwise and slide it off the left side of the shaft.
- 8 Remove the pinion shaft from the winch housing.
- 9 Remove both pinion bushings. Use a soft metal drift equal to the outside diameter of the bushing and tap with a rubber mallet.

**NOTICE** Component damage hazard. Place a block in between the walls of the winch housing to prevent the housing from bending while removing the bushings.

- 10 Remove the winch housing from the machine.

REV A

WINCHES

## How to Assemble a One-speed Winch

**CAUTION** Bodily injury hazard. Cables can fray. Always wear adequate hand protection when handling cable.

Note: Refer to the figure on page 5-13, for an exploded view of the One-speed Winch.

- 1 Place one side of the winch housing over the jaws of a vise. Open the vise until the jaws are wider than the outside diameter of the bushing.
- 2 Insert a soft metal drift through the opposite bushing hole. Tap the drift with a rubber mallet to push the bushing into place.
- 3 Repeat steps 1 and 2 to insert the other bushing.

Note: Use a piece of flatbar or wood in between the drift and the bushing to prevent any damage to the bushing.

- 4 Add two drops of 30W oil to both pivot points on each ratchet pawl.

**CAUTION** Bodily Injury Hazard. Overlubrication of the ratchet pawl may result in oil coming in contact with the surface of the winch brake leading to an unsafe working condition. Do not allow any oil on the brake or pressure plate.

- 5 Install the winch housing onto the mast. Be sure the winch drum is toward the top.

- 6 Insert the longer threaded end of the pinion shaft approximately halfway through the left bushing.
- 7 Apply a small amount of multi-purpose grease to the large threaded section of the pinion shaft, under the gear nut. Screw the pinion gear onto the pinion shaft with the gears toward the left side of the winch housing.
- 8 Install, in order, a brake disk, a ratchet gear, a brake disk, a pinion plate and a pinion spacer onto the pinion shaft.

**NOTICE** Component damage hazard. Do not allow grease or oil onto the brake disks or the ratchet gear.

Note: The teeth on the ratchet gear must curve away from the right side of the winch housing.

- 9 Push the pinion shaft to the right, through the right pinion bushing, and install the pinion shaft retaining ring.

Note: Use your fingers to push the ratchet pawls outward while pushing the pinion shaft through the right bushing. Be sure the ratchet pawls are in firm contact with the ratchet gear and that all parts move freely.

- 10 Install the two jam nuts to the right side of the pinion shaft one at a time, and tighten.
- 11 Position both handles on the pinion shaft in opposite directions. Install and tighten the lock nuts.

## WINCHES

REV A

- 12 Lubricate the outside of the frame spacer with multi-purpose grease. Insert the frame spacer into the drum.
- 13 Install the cable drum. Be sure the drum gears mesh with the ratchet gears.
- 14 Install the drum bolt keeper. Push the drum bolt through the winch housing, drum cover and drum. Be sure the head of the drum bolt is on the drum gear side of the winch.
- 15 Place the drum gear cover in position with the drum bolt slot under the drum bolt keeper.
- 16 Install the drum bolt jam nut hand tight.
- 17 Install the housing spacer with the head of the housing spacer bolt on the right side of the winch and through the slotted portion of the drum gear cover. Place the nut on the end of the bolt and tighten.
- 18 Torque the drum bolt nut to  
20 to 25 ft-lbs / 27 to 34 Nm.

**NOTICE** Component damage hazard. Overtightening the drum bolt jam nut may cause damage to the frame spacer and prevent the drum from spinning freely.

- 19 Lubricate the teeth of the drum gear and the pinion nut that meshes with the drum gear with multi-purpose grease.

**CAUTION** Bodily Injury Hazard. Overlubrication of the ratchet pawl may result in oil coming in contact with the surface of the winch brake leading to an unsafe working condition. Do not allow any oil on the brake or pressure plate.

- 20 Rotate the drum so that the two square cable keeper holes are at the top. Install the cable keeper clip to the outside of the drum with the two carriage bolts coming through from the inside. Install the lock washers and nuts finger tight. Do not tighten.
- 21 Route the end of the cable around the winch drum and out through the remaining hole on the left side wall of the drum.

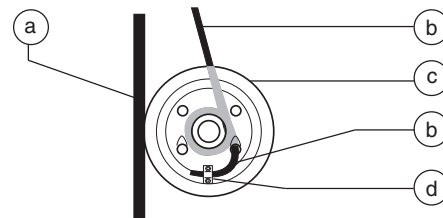

- a number one column
- b cable
- c winch drum
- d cable keeper clip

- 22 Insert the end of the cable under the cable keeper clip approximately  $\frac{1}{2}$  inch / 13 mm and tighten the cable keeper clip fasteners.
- 23 While holding the cable tight on the drum, rotate the drum and spool the cable onto the drum evenly.

**NOTICE** Component damage hazard. Be sure the cable winds onto the winch drum evenly.

REV A

WINCHES

## One-speed Winch Assembly

Index No.	Description	Index No.	Description
1	Disc Brake	11	Drum Lock Bolt
2	Pinion Gear	12	Winch Gear Cover
3	Pinion Shaft	13	Screw
4	Retaining Ring	14	Lock Nut
5	Pinion Shaft Bushing	15	Drum Bolt
6	Winch Handle	16	Hex Jam Nut
7	Nylock Nut	17	Frame Spacer
8	Ratchet Pawl Kit	18	Pinion Shaft Spacer
9	Cable Keeper Kit	19	Pinion Plate
10	Drum Spacer	20	Ratchet Gear

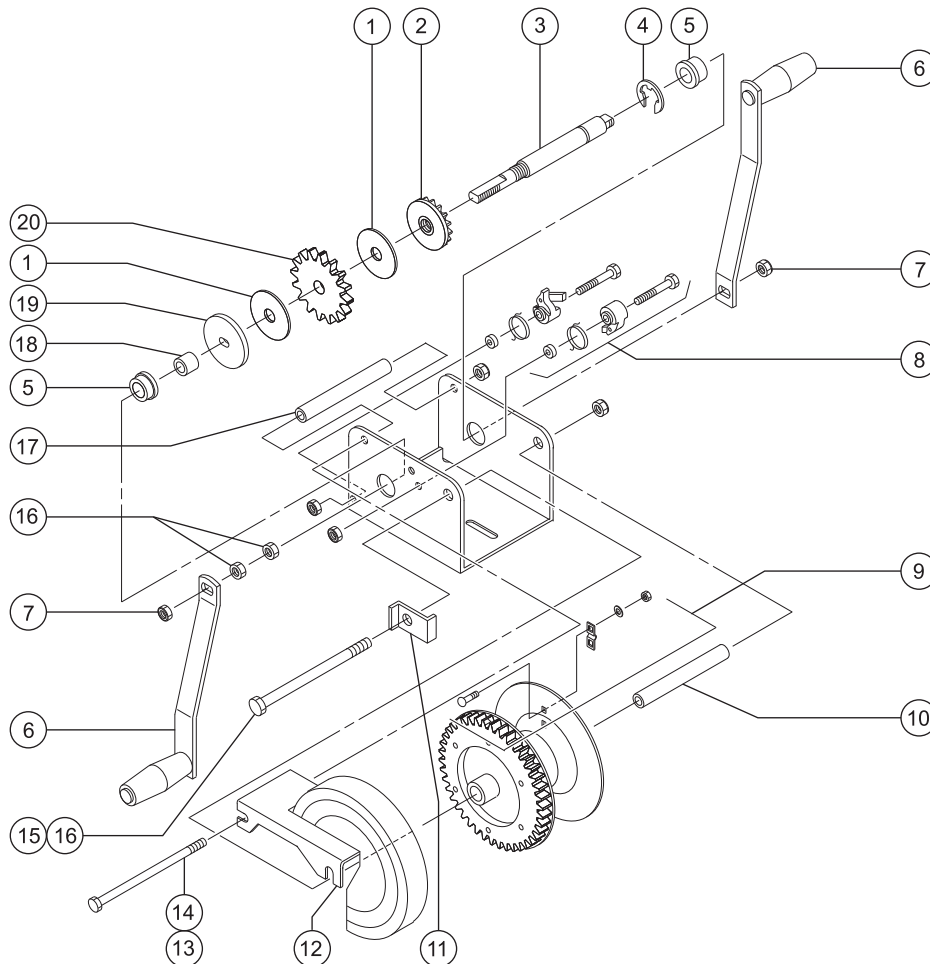

## WINCHES

REV A

**3-2****Two-speed Winch****How to Disassemble a Two-speed Winch**

**CAUTION** Bodily injury hazard. Cables can fray. Always wear adequate hand protection when handling cable.

- 1 Fully lower the carriage and remove the load handling attachment.
- 2 Remove the cable retaining fasteners from the winch drum. Remove the cable from the drum.
- 3 Remove both handle retaining fasteners from the pinion shaft. Remove the handles.
- 4 Remove the drum bolt and spacer. Remove the drum, drum gear cover and housing spacer.
- 5 Remove the input shaft cover.
- 6 Remove the mounting fasteners from the spring and ball housing.
- 7 Remove the two springs and balls from the spring and ball housing.
- 8 Slide the input shaft out of the winch housing.
- 9 Remove the retaining ring from the pinion shaft.
- 10 Remove the lock nut from the end of the pinion shaft (located on the outside of the winch housing).

Note: Note the location and position of the components on the pinion shaft.

- 11 Slide the pinion shaft to the right and remove the pinion spacer, pinion plate, ratchet gear, and friction disks. Turn the pinion gear counterclockwise and slide it off the left side of the shaft.
- 12 Remove both pinion bushings. Use a soft metal drift equal to the outside diameter of the bushing and tap with a rubber mallet.

**NOTICE** Component damage hazard. Place a block between the walls of the winch housing to prevent the housing from bending while removing the bushings.

REV A

WINCHES

## How to Assemble a Two-speed Winch

**CAUTION** Bodily injury hazard. Cables can fray. Always wear adequate hand protection when handling cable.

Note: Refer to the figure on page 5-17, for an exploded view of the Two-speed Winch.

- 1 Place one side of the winch housing over the jaws of a vise. Open the vise until the jaws are wider than the outside diameter of the bushing.
- 2 Insert a soft metal drift through the opposite bushing hole. Line up the tab on the bushing to the hole in the winch housing. Tap the drift with a rubber mallet to push the bushing into place.
- 3 Repeat steps 1 and 2 to insert the other bushing.

Note: Use a piece of flatbar or wood between the drift and the bushing to prevent any damage to the bushing.

- 4 Add two drops of 30W oil to both pivot points on each ratchet pawl.

**CAUTION** Bodily Injury Hazard. Overlubrication of the ratchet pawl may result in oil coming in contact with the surface of the winch brake leading to an unsafe working condition. Do not allow any oil on the brake or pressure plate.

- 5 Install the winch housing on the mast. Be sure the winch drum is toward the top.
- 6 Insert the longer threaded end of the pinion shaft approximately halfway through the right side bushing.

- 7 Apply a small amount of multi-purpose grease to the large threaded section of the pinion shaft, under the gear nut. Slide the pinion shaft gears onto the pinion shaft. Install the pinion gear onto the pinion shaft with the gears toward the right side of the winch housing. Screw onto large threads hand tight.
- 8 Install, in order, a friction disk, a ratchet gear, a friction disk, a pinion plate and a pinion spacer onto the pinion shaft.

**NOTICE** Component damage hazard. Do not allow grease or oil onto the brake disk, ratchet gear or the teflon spacer.

Note: The teeth on the ratchet gear must curve toward the left side of the winch housing.

- 9 Install the pinion shaft retaining ring onto the pinion shaft.

Note: Use your fingers to push the ratchet pawls outwards while pushing the pinion shaft through the left bushing. Be sure the ratchet pawls are in firm contact with the ratchet gear and that all parts move freely.

- 10 Install the lock nut on the left side of the pinion shaft.
- 11 Install the input shaft approximately half way through the left side of the winch housing.
- 12 Slide the left side bushing, spring and ball housing, spacer, input shaft gears and right side bushing onto the input shaft.
- 13 Install the ball and spring into the spring and ball housing. Install the mounting fasteners.

## WINCHES

REV A

- 14 Lubricate the outside of the frame spacer with multi-purpose grease and insert it into the drum.
- 15 Install the cable drum. Be sure the drum gears mesh with the ratchet gears.
- 16 Install the drum bolt keeper. Push the drum bolt through the winch housing, drum cover and drum. Be sure the head of the drum bolt is on the drum gear side of the winch.
- 17 Install the drum bolt jam nut and torque to 20 to 25 ft-lbs / 27 to 34 Nm.

**NOTICE** Component damage hazard. Overtightening the drum bolt jam nut may cause damage to the frame spacer and prevent the drum from spinning freely.

- 18 Lubricate the teeth of the drum gear and the pinion nut with multi-purpose grease.

**CAUTION** Bodily Injury Hazard. Overlubrication of the ratchet pawl may result in oil coming in contact with the surface of the winch brake leading to an unsafe working condition. Do not allow any oil on the brake or pressure plate.

- 19 Install the input shaft cover.
- 20 Rotate the winch drum so that the oblong slot is visible and horizontal.
- 21 Install the cable keeper clip on the outside of the winch drum with one carriage bolt coming through from the inside. Install the lock washer and nut finger tight. Do not tighten the nut.

- 22 Route the end of the cable between the winch drum and the number one column. Proceed around the drum and up through the horizontal slot in the winch drum. The cable is then fed under the lefthand side of the cable clip, pulled forward, looped, and then fed under the right hand side of the cable keeper clip. The raw end of the cable is then fed into the righthand side of the horizontal slot in the winch drum.

**WARNING** Crushing hazard. Failure to properly route the cable may result in a winch brake failure.

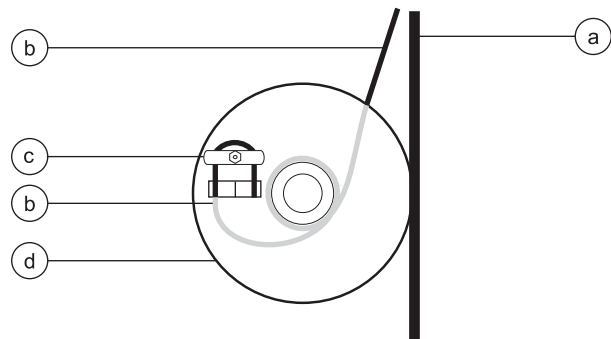

- a Number one column  
b Cable  
c Cable keeper clip  
d Winch drum

- 23 Tighten the cable keeper fastener.
- 24 While holding the cable tight on the drum, rotate the drum with a handle and spool the cable onto the drum evenly.

**NOTICE** Component damage hazard. Be sure the cable winds onto the winch drum evenly.

REV A

WINCHES

## Two-speed Winch Assembly

Index No.	Description	Index No.	Description
1	Reel Lock Bolt	11	Input Shaft Assembly
2	Reel Cover	12	Brake Spring Spacer
3	Cable Keeper	13	Detent Block Assembly
4	Reel Spacer	14	Pinion Gear
5	Gear Cover	15	Disc Brake
6	Ratchet Pawl Kit	16	Ratchet Gear
7	Retaining Ring	17	Pinion Plate
8	Sintered Iron Ring	18	Brake Spacer
9	Pinion Shaft Assembly	19	Pinion Shaft Bushing
10	Handle	20	Base Spacer

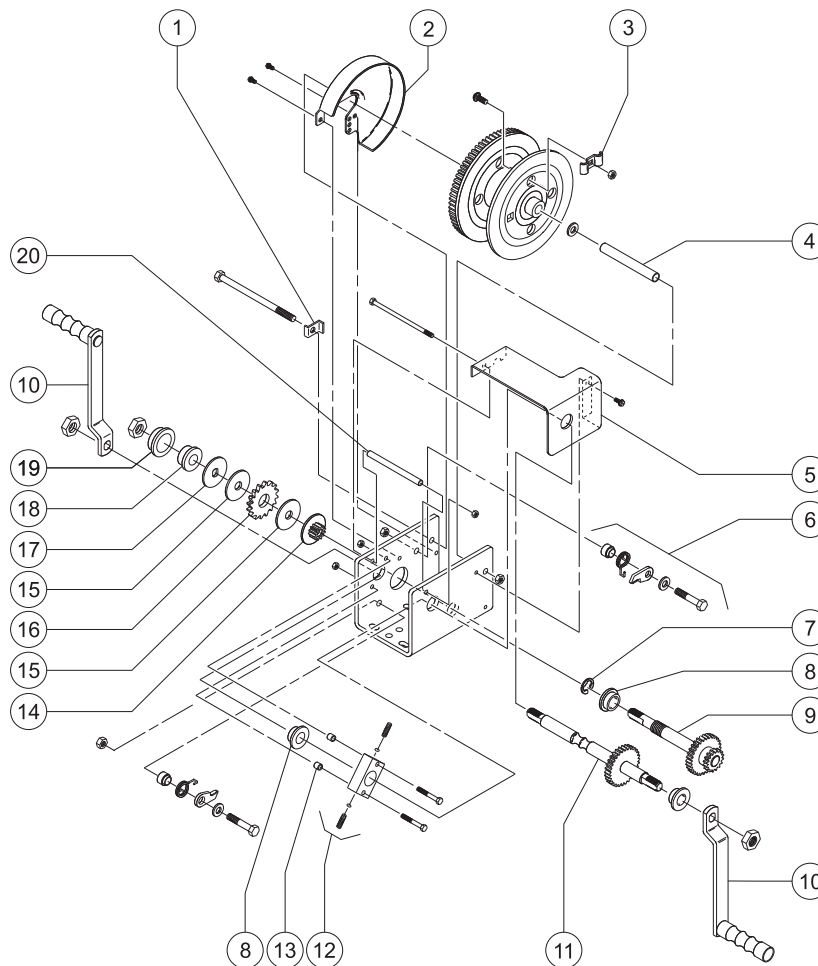

---

**Genie Scandinavia**

Phone +46 31 575100  
Fax +46 31 579020

---

**Genie France**

Phone +33 (0)2 37 26 09 99  
Fax +33 (0)2 37 26 09 98

---

**Genie Iberica**

Phone +34 93 579 5042  
Fax +34 93 579 5059

---

**Genie Germany**

Phone 0800 180 9017  
Phone +49 422 149 1818  
Fax +49 422 149 1820

---

**Genie U.K.**

Phone +44 (0)1476 584333  
Fax +44 (0)1476 584334

---

**Genie Mexico City**

Phone +52 55 5666 5242  
Fax +52 55 5666 3241

**Genie North America**

Phone 425.881.1800  
Toll Free USA and Canada  
800.536.1800  
Fax 425.883.3475

---

**Genie Australia Pty Ltd.**

Phone +61 7 3375 1660  
Fax +61 7 3375 1002

---

**Genie China**

Phone +86 21 53852570  
Fax +86 21 53852569

---

**Genie Malaysia**

Phone +65 98 480 775  
Fax +65 67 533 544

---

**Genie Japan**

Phone +81 3 3453 6082  
Fax +81 3 3453 6083

---

**Genie Korea**

Phone +82 25 587 267  
Fax +82 25 583 910

---

**Genie Brasil**

Phone +55 11 41 665 755  
Fax +55 11 41 665 754

---

**Genie Holland**

Phone +31 183 581 102  
Fax +31 183 581 566

Distributed By:

**Service Manual  
Superlift Advantage**

*(from serial number SLA04-25259)*

**Part No.  
115407**

**Rev A**

**Genie**  
A TEREX COMPANY