

SOLUTIONS TO SIMPLIFY YOUR WORKLOAD

Material Handling, Storage & Specialized Equipment

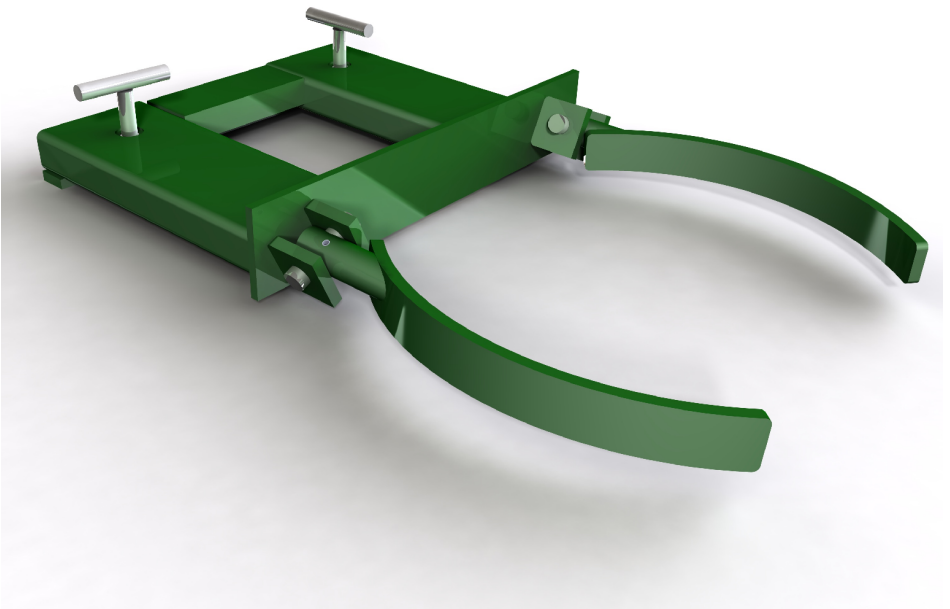

DRUM SNATCHER F87398A2



Notice to Purchaser

All statements, technical information, and recommendations related to Valley Craft's products are based on information believed to be reliable, but the accuracy or completeness is not guaranteed. Before using this product, you must determine if it is suitable for your intended application or situation. You assume all risks and liability associated with such use or implementation.

Product Testing

We perform vigorous in-house safety and durability testing to ensure that the performance of our products meets the demands of the workplace. We also expect the same from manufacturers who supply components for our products. We do this to ensure that Valley Craft is a name that our customers trust and associate with quality.

Publication Revision Notice

Following is a history of changes to this publication, including the current revision.

Previous Revisions: none

Current Revision: A (11/07)

Copyright Notice

© Valley Craft, Inc. All rights reserved. No part of this publication may be reproduced, photocopied, stored on a retrieval system, or transmitted without the express written consent of Valley Craft.

Trademarks

The Valley Craft logo is a Valley Craft Trademark. All other company or product names are trademarks or registered trademarks of their respective owners. Use of a term in this document should not be regarded as affecting the validity of any trademark or service mark.

■ Table of Contents

Safety	4
• Safety Overview	4
• Safety Message Conventions.....	5
• MSDS and Additional Safety.....	6
Product Description	7
• Features	7
• Receiving and Inspection.....	7
Operation	8
• Operating Procedures	8
Maintenance	9
• Maintenance Procedures.....	9
Troubleshooting	9
• Troubleshooting Procedures	9
Replacement	10
• Replacement Procedures.....	10
Parts List	11
• Exploded View.....	11
• Replacement Parts.....	11
Load Center Information	12

Safety

Read and understand all safety information and become familiar with all safety symbols contained in this section before moving, operating or performing maintenance on this equipment.

■ Safety Overview

The following general safety precautions must be observed during all phases of operation, service, and repair of this equipment. Failure to comply with these precautions or with specific safety messages elsewhere in this manual may impair the protection provided by the equipment. Such noncompliance would also violate safety standards of design, manufacture, and intended use of the instrument.

- Observe all safety signs posted in your facility.
- Observe warnings, cautions, handling information, storage requirements and other information on all container labels.
- Wear safety glasses with side shields.
- Wear the proper protective clothing, gloves and other protective equipment before handling any chemicals.
- Group the containers for the move by Hazard Class. Do not move acids with toxics, or oxidizers.
- Use maximum care and good judgment in preventing accidents and injuries and seeking first aid.
- Report unsafe conditions, equipment, practices, and on-job injuries.
- Understand your supervisor's instructions. Ask questions if you do not know how to do the job safely.
- Do not engage in tasks which you believe might be unsafe without consulting your supervisor.
- Clean up the work area and equipment upon job completion.
- Before you start work on any electrical system or circuit, check all power sources to ensure that the system or circuit is de-energized.
- Know the hazardous or potentially hazardous substances you work with or are present in your work area. Review Material Safety Data Sheets (MSDS) on these substances, or contact your supervisor.

■ Safety Message Conventions

There are three types of safety notices contained in this manual: **Safety**, **Danger**, and **Warning** notices. These notices precede the procedural step or portion of text that presents the safety hazard.



DANGER

- **DANGER indicates an imminently hazardous situation which, if not avoided, will result in death or serious injury. This signal word is to be limited to the most extreme situations.**
-



WARNING

- **WARNING indicates a potentially hazardous situation which, if not avoided, could result in death or serious injury.**
-



CAUTION

- **CAUTION indicates a potentially hazardous situation which, if not avoided, may result in minor or moderate injury. It may also be used to alert against unsafe practices**
-

■ Material Safety Data Sheets (MSDS)

A Material Safety Data Sheet (MSDS) provides information on the safe use, handling and potential hazards of a product. This information assists with the proper response in the event of an emergency.

Valley Craft maintains material safety data sheets (MSDSs) on all our products. You are urged to obtain copies of the relevant MSDSs before using our products to protect yourself and others against any known health or safety hazards described in these MSDSs. Valley Craft strives to make safety a top priority. Do not hesitate to contact us to discuss any safety aspects of our products.

The relevant MSDS codes for Valley Craft products are listed below.

- www.conocophillips.com
Super ATF Transmission Oil, MSDS Code 778846
Super-Sta Grease, MSDS Code 775440
- www.batteriesplus.com
Sealed Lead Acid Battery
SLA for English version
- [Paint](#)
Contact Valley Craft Customer Service at 1-800-328-1480 or on the Web at customer@valleycraft.com.

■ Additional Safety Information

As with any mechanical device, care must be taken during the installation, operation, and maintenance of the device in order to realize the maximum benefit from its ownership.

When transporting drums it is recommended that the drum is lowered as close to the floor as possible to reduce the chances of accidents during transport.

Note: All personnel involved in the use and maintenance of this device should be thoroughly familiar with the information contained in this manual. Furthermore, it is recommended that all personnel be given adequate instruction and a sufficient period of training in its actual use to insure safety of personnel and proper care of the equipment. It is suggested that the units be initially operated empty until becoming familiar with how the unit handles.

Product Description

This Gravity-Actuated Mechanical Drum Snatcher is most efficient on consistently-sized loads. Equipped with standard jaws only that grip with pressure equal to the weight of the drum, then moves, stacks and palletizes 55 gallon steel-ringed drums.

Specifications

The **Drum Snatcher** specifications are shown in Table 1.

Table 1. Specifications

Dimensions	Height: 4 in. x Width 22 in.
Weight	79 lbs
Load Capacity	Level: 800 lbs
Distance Between Forks	19 5/8 in.
Fork Tube Size	Height: 1 5/8 in x Width: 5 5/8 in x Length: 16 in
Jaw Size	Height: 3in x Length: 16 5/8 in

■ Features

The **Drum Snatcher** offers state-of-the-art design a unique knuckle-gripping system and natural pressure of the loaded drum for gripping 55 gallon steel ringed drums.

■ Receiving and Inspection

When unpacking the **Drum Snatcher**, inspect the equipment for damage or mishandling. If damage is noted, file a damage claim with the carrier within 24 hours and call Valley Craft at 1-800-328-1480. Do not attempt to use the equipment.

Compare the contents of the shipment with the bill of lading. Report any missing items to the carrier and to Valley Craft immediately.

■ **Operating Procedures**

Only Authorized personnel are permitted to use the Drum Snatcher. Every load and every situation is different. Every lift must be evaluated and planned. All personnel should be given adequate instruction and a sufficient period of training in actual use of the Auto Grip to insure proper care of the Auto Grip. Observe the following procedures when using this equipment.

This Auto Grip must be assembled and adjusted using the instructions supplied with the hardware pack. Insert forks of Lift Truck into fork tubes of Auto Grip and secured with the “T” Bolts.

● **Lifting Steel Drums**

To engage, approach the drum with the jaws midway between upper and lower rolling ribs. Lower jaws slightly upon contact with drum to assist opening. Ease the Lift Truck into the drum, applying pressure against the drum. The jaws should go around the drum as the operator advances and will grip the drum just below the upper rolling rib as the carriage is raised. Transport drum at minimum practical height and speed.

● **Lowering Steel Drums**

To disengage, lower until jaws contact lower rolling rib. Continue to lower and back off as jaws open.

Maintenance

■ Maintenance Procedures

The following inspections are recommended on a daily basis when this device is subject to frequent use, but no less than monthly. Discontinue use if any of the conditions shown below are found until repairs are made.

1. Inspect the structural members and welds for cracks, deformation or excessive corrosion.
2. Inspect the bearing surfaces for excessive wear.

Troubleshooting

■ Troubleshooting Procedures

The **Drum Snatcher** is a quality product that is designed and manufactured to provide prolonged service under normal operating conditions. If troubleshooting is required, it should be performed only by qualified personnel who are familiar with the equipment.

Replacement

■ Replacement Procedures

Occasionally, it will be necessary to replace a part that has been Damaged or worn. Many parts on this Drum Snatcher are replaceable. If Replacement of a part is required, it should be performed only by Qualified personnel who are familiar with the equipment.

See Sheet 11 for available replacement parts. Identify the part number you need. Contact Valley Craft Customer Service at 1-800-328-1480 or on the Web at customer@valleycraft.com.

Information required when contacting Valley Craft:

- A. Company name and address
- B. Contact persons name
- C. Telephone number
- D. E-Mail address
- E. Model Number
- F. Date of manufacture
- G. Part umber of Parts ordering

The model number and date of manufacture is stamped on a metal tag located on the frame.

DRUM SNATCHER

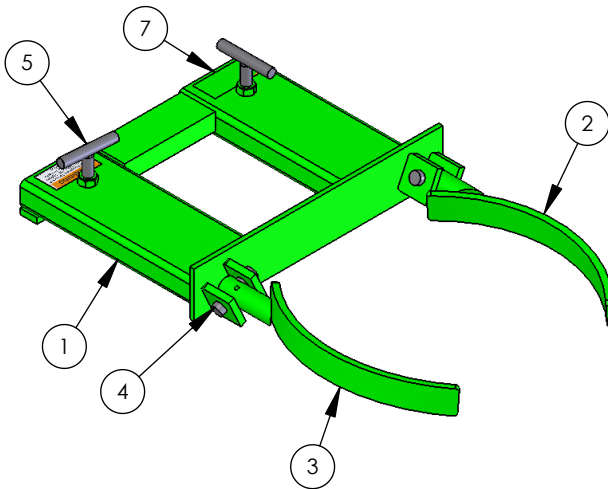

ITEM NO.	PART NUMBER	DESCRIPTION	QTY
1	F62104A0	FRM-WLDMT-SGL GRIP SNATCHER	1
2	F62101A6	ARM WLDMT-LH/ DRUM SNATCHER	1
3	F62102A7	ARM WLDMT-RH/DRUM SNATCHER	1
4	F30060A0	PIN-PIVOT	2
5	Z10526A2	BOLT-TEE 3/4-10 x 3-1/4	2
6	Z40346A8	DECAL-DRUM ATT/DRUM SNATCHER	1
7	Z41464A8	DECAL-T-BOLT	2

DRUM SNATCHER

LOAD CENTER SPECIFICATIONS

LOST LOAD CENTER IS A MEASURE OF HOW MUCH "CAPACITY" OF THE FORKLIFT OR TRUCK IS LOST WHEN AN ATTACHMENT IS ADDED.

ADDING/SUBTRACTING SOMETHING TO THE FORKLIFT OR TRUCK AFFECTS HOW MUCH LOAD IT CAN SUPPORT AND STILL STAY STABLE.

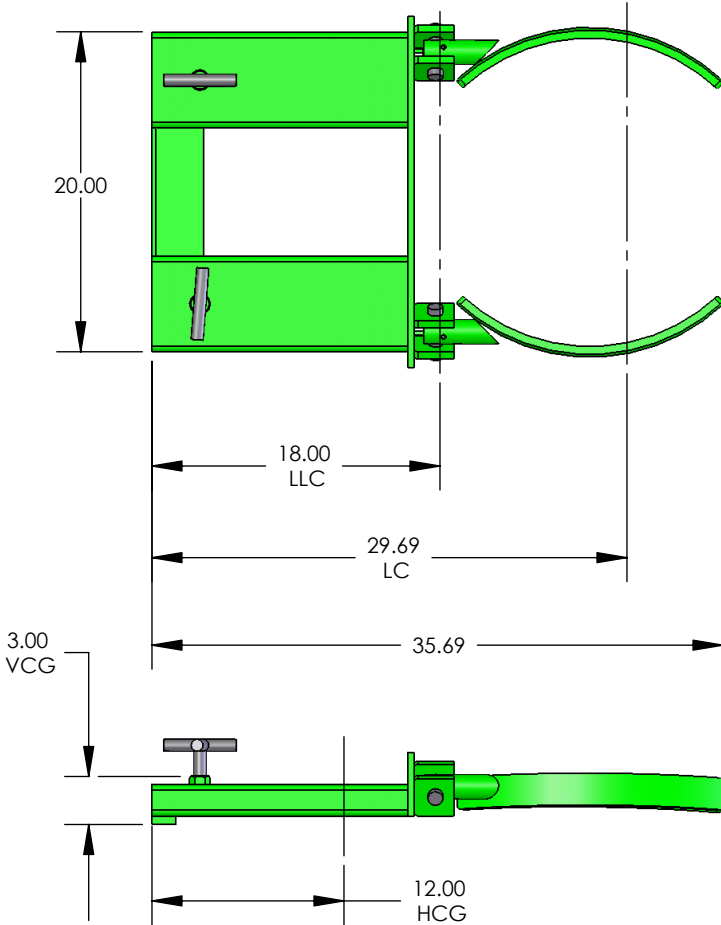

HCG = HORIZONTAL CENTER OF GRAVITY
LC = LOAD CENTER
LLC = LOST LOAD CENTER
VCG = VERTICAL CENTER OF GRAVITY

Warranty and Limitation of Liability

Valley Craft products are warranted for a period of one (1) year from date of shipment from Valley Craft's plant to be free from defects in material and workmanship under correct use, normal operation and proper application. However, parts of other than Valley Craft manufacture are subject ONLY to the original manufacturer's warranty. Valley Craft's obligation under warranty shall be limited to repair or exchange, at Valley Craft's option, FOB origin factory, of any Valley Craft product or part which proves to be defective as provided herein. Valley Craft reserves the right to either inspect the product at Buyer's location, or require it to be returned to the factory for inspection. The warranty contained herein does not extend to goods damaged, or subject to accident, abuse or misuse after shipment from Valley Craft's factory, nor to goods altered or repaired by anyone other than an authorized Valley Craft representative.

Buyer or user shall not alter, modify or use a Valley Craft product for anything other than its intended function. Valley Craft shall not in any way be responsible for the consequences of any such alteration, modification or misuse.

VALLEY CRAFT MAKES NO EXPRESS WARRANTIES OTHER THAN THOSE WHICH ARE SPECIFICALLY DESCRIBED HEREIN. Any description of the goods sold hereunder, including any references to Buyer's specifications and any descriptions in catalogs, circulars and other written material published by Valley Craft, is for the sole purpose of identifying such goods and shall not create an express warranty that the goods shall conform to such descriptions.

THIS WARRANTY IS EXPRESSLY IN LIEU OF ALL OTHER WARRANTIES, EXPRESS OR IMPLIED. THERE ARE NO IMPLIED WARRANTIES OF MERCHANTABILITY OR FITNESS FOR A PARTICULAR PURPOSE. THIS WARRANTY STATES VALLEY CRAFT'S ENTIRE AND EXCLUSIVE LIABILITY AND BUYER'S EXCLUSIVE REMEDY FOR ANY CLAIM OR DAMAGES IN CONNECTION WITH VALLEY CRAFT PRODUCTS, THEIR DESIGN. SUITABILITY FOR USE, INSTALLATION OR OPERATION OR FOR ANY CLAIMED DEFECTS. VALLEY CRAFT WILL IN NO EVENT BE LIABLE FOR INCIDENTAL OR CONSEQUENTIAL DAMAGES WHATSOEVER, NOR FOR ANY SUM IN EXCESS OF THE PRICE RECEIVED FOR THE GOODS FOR WHICH LIABILITY IS CLAIMED.

Technical Assistance/Warranty Procedure

What's Covered:

- Parts and Labor to correct manufacturer's defect within one year of purchase.
- Freight Cost

What's Not:

- Normal wear items (seal kits, bearings, tires, etc.)

What Voids the Warranty:

- Dirt/Grime that directly causes malfunction of product
 - Abuse (i.e. Overloading, damaged, not properly maintained, etc.)
 - Product altered by customer
- *See "Items not Under Warranty" below for items that have the warranty voided.

Items Under Warranty (less than one year old):

- Warranty replacement parts are provided only when the problem can be identified with near certainty. If not, the customer will return item to Valley Craft, freight collect, for troubleshooting and/or repair. When repaired, product will be returned to customer,



Valley Craft is a modern metals fabricating manufacturer specializing in material handling, storage and specialized solutions designed with safety and usability in mind, and the simplification of even the heaviest of workloads. Since developing the first hand truck with a brake in 1952, Valley Craft has been a true pioneer in safety-conscious material handling and solution-driven products. Our commitment to continuous improvement in a Lean Manufacturing environment results in safe, functional, quality equipment at affordable prices.

Valley Craft, Inc.

2001 South Highway 61
Lake City, Minnesota 55041 U.S.A.

Phone: (651) 345-3386

Toll Free: (800) 328-1480

Fax: (651) 345-3606

E-Mail: customer@valleycraft.com

Web: valleycraft.com • ovation-solutions.com
