

TRAILER TONGUE BOX MOUNTING INSTRUCTIONS

Read these instructions to familiarize yourself with assembly and installation. This tool box is designed for certain applications only. Northern Tool & Equipment is not responsible for issues arising from modification or improper use of this product such as an application for which it was not designed. We strongly recommend that this product not be modified and/or used for any application other than that for which it was designed.

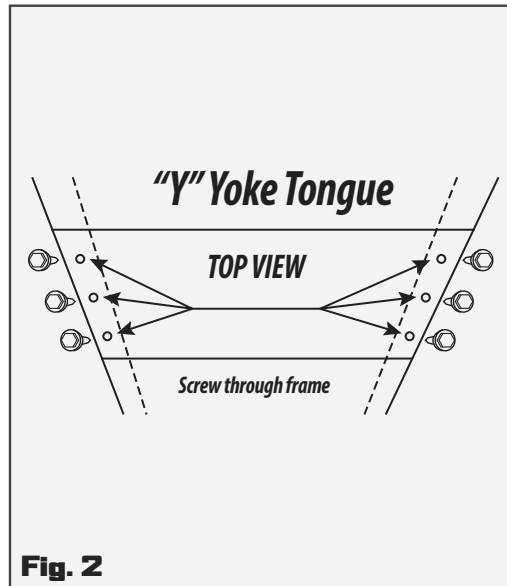
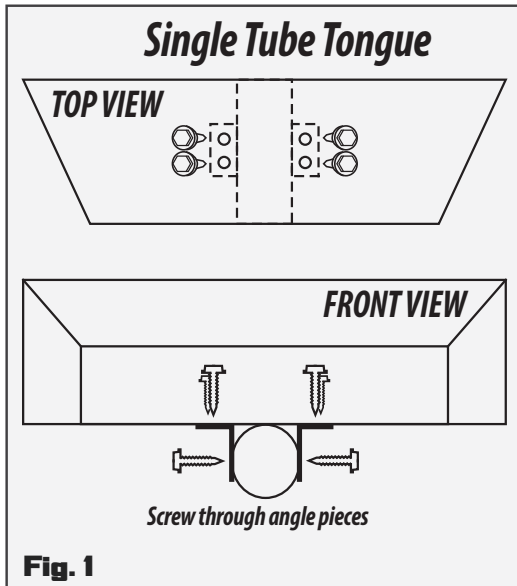

NOTE: If your truck has a bed liner, use these instructions as a guide only.

Due to the many differences in bed liner thickness and fit, longer fasteners are highly recommended.

You will need to ensure that your new truck box is mounted securely to the truck, not the bed liner.

⚠ CAUTION

This tool box must be securely mounted to prevent movement or shifting.

⚠ WARNING

Any leaking caused by unsealed holes in the box bottom will void the warranty.

SINGLE TUBE TONGUE MOUNTING (Fig. 1)

1. Carefully place the Trailer Tongue Box in the location where you expect to mount it. Ensure the box is centered left to right on the tongue, and the lid will not contact anything when opened. Ensure the leveling crank on the trailer (if present) will not hit the box when the crank handle is rotated.
2. Locate the two metal angle pieces that are supplied in the mounting kit.
3. Have an assistant hold the box level while you align the angle pieces with the tongue of the trailer and the bottom of the box. Mark the angle locations on the bottom of the box for future mounting locations. (See Fig. 1).
4. Locate the self-tapping screws included with the mounting kit. Hold the metal angle in place against the bottom of the box and drill through the bottom of the box and into the metal angles.
5. Place the box back on the trailer tongue in the original location. Drill through the angles and into the trailer tongue.

"Y" YOKE TONGUE MOUNTING (Fig. 2)

1. Carefully place the aluminum Trailer Tongue Box in the location where you expect to mount it. Ensure the box is centered left to right on the tongue, and the lid will not contact anything when opened. Ensure the leveling crank on the trailer (if present) will not hit the box when the crank handle is rotated.
2. If the box lines up with the two sides of the yoke, and the lid will open without interference, use the self-drilling screws to attach the box to the trailer frame.
3. If necessary for additional stability, use the two pieces of metal angle to attach to the box bottom and trailer frame. If additional stability is not necessary, discard the mounting kit.

For Customer Service or Warranty Information: 1-800-222-5381



NORTHERN
TOOL + EQUIPMENT

Distributed by:
Northern Tool & Equipment Company, Inc.
Burnsville, Minnesota 55306
www.northerntool.com

LIMITED WARRANTY

Northern Tool and Equipment Company, Inc. ("We" or "Us") warrants to the original purchaser only ("You" or "Your") that the Northern Tool + Equipment product purchased will be free from material defects in both materials and workmanship, normal wear and tear excepted, for five years from date of purchase. The foregoing warranty is valid only if the installation and use of the product is strictly in accordance with product instructions. There are no other warranties, express or implied, including the warranty of merchantability or fitness for a particular purpose. If the product does not comply with this limited warranty, Your sole and exclusive remedy is that We will, at our sole option and within a commercially reasonable time, either replace the product or product component without charge to You or refund the purchase price (less shipping). This limited warranty is not transferable.

Limitations on the Warranty

This limited warranty does not cover: (a) normal wear and tear; (b) damage through abuse, neglect, misuse, or as a result of any accident or in any other manner; (c) damage from misapplication, overloading, or improper installation; (d) improper maintenance and repair; and (e) product alteration in any manner by anyone other than Us, with the sole exception of alterations made pursuant to product instructions and in a workmanlike manner.

Obligations of Purchaser

You must retain Your product purchase receipt to verify date of purchase and that You are the original purchaser. To make a warranty claim, contact Us at 1-800-222-5381, identify the product by make and model number, and follow the claim instructions that will be provided. The product and the purchase receipt must be provided to Us in order to process Your warranty claim. Any returned product that is replaced or refunded by Us becomes our property. You will be responsible for return shipping costs or costs related to Your return visit to a retail store.

Remedy Limits

Product replacement or a refund of the purchase price is Your sole remedy under this limited warranty or any other warranty related to the product. We shall not be liable for: service or labor charges or damage to Your property incurred in removing or replacing the product; any damages, including, without limitation, damages to tangible personal property or personal injury, related to Your improper use, installation, or maintenance of the product or product component; or any indirect, incidental or consequential damages of any kind for any reason.

Assumption of Risk

You acknowledge and agree that any use of the product for any purpose other than the specified use(s) stated in the product instructions is at Your own risk.

Governing Law

This limited warranty gives You specific legal rights, and You also may have other rights which vary from state to state. Some states do not allow limitations or exclusions on implied warranties or incidental or consequential damages, so the above limitations may not apply to You. This limited warranty is governed by the laws of the State of Minnesota, without regard to rules pertaining to conflicts of law. The state courts located in Dakota County, Minnesota shall have exclusive jurisdiction for any disputes relating to this warranty.

For Customer Service or Warranty Information: 1-800-222-5381



NORTHERN[®]
TOOL + EQUIPMENT

Distributed by:
Northern Tool & Equipment Company, Inc.
Burnsville, Minnesota 55306
www.northerntool.com