



ESCO EQUIPMENT SUPPLY COMPANY

# Instruction Manual

## Heavy Duty Jack Stand

### Model #10802 #10804



**FOR YOUR SAFETY**

Please read these instructions carefully and retain them for future use





ESCO EQUIPMENT SUPPLY COMPANY

**CAUTION:**

**READ AND FOLLOW ALL WARNINGS, CAUTIONS AND INSTRUCTIONS ASSOCIATED WITH THE PROPER USE OF THIS PRODUCT, FAILURE TO COMPLY COULD RESULT IN DEATH, BODILY INJURY AND/OR DAMAGE TO EQUIPMENT.**

*This product as well as all tire tools, should never be used by persons unless they have been trained properly according to the O.S.H.A. regulation #29CFR 1910.177 entitled "Servicing Single-Piece & Multipiece Rim Wheels". Copies of this regulation can be obtained by contacting this manufacturer. 800-352-9852 or sales.esco.net.*

**Specifications**

<b>Model</b>	<b>Capacity</b>	<b>Min. Height</b>	<b>Max. Height</b>	<b>Base Dimension</b>
<b>10802</b>	<b>20 Ton</b>	<b>18.5"</b>	<b>27"</b>	<b>13" x 13"</b>
<b>10804</b>	<b>25 Ton</b>	<b>27"</b>	<b>41"</b>	<b>13" x 13"</b>

**Important Safety Information**

Read these safety warnings before operation.

**WARNING!**

Failure to heed these warnings may result in loss of load, damage to jack stands, and / or jack stand failure resulting in personal injury or property damage.

**WARNING!**

Do not overload Jack stands beyond rated capacity.

Overloading can cause damage to or failure of the jack stands and bodily harm.

Position load on center of saddle only. Always use stands in pairs on hard level surface capable of sustaining the load. Use of stands on anything other than a hard level surface can result in stand instability and possible loss of load.





## ESCO EQUIPMENT SUPPLY COMPANY

### Operation

1. Refer to your vehicle owner's manual for proper jacking procedures. Lift only on areas of the vehicle specified by the vehicle manufacturer.
2. Position stands under vehicle at points specified by the vehicle manufacturer as proper load support points.
3. To adjust stands:
  1. Screw low/high stand fitted with thrust bearing. (10802)
  2. Reinforced low stand with controlled pin holes, turn, and oil jack stand post.
  3. Reinforce high stand with holes without controlled pin.
4. Carefully lower load onto stands.

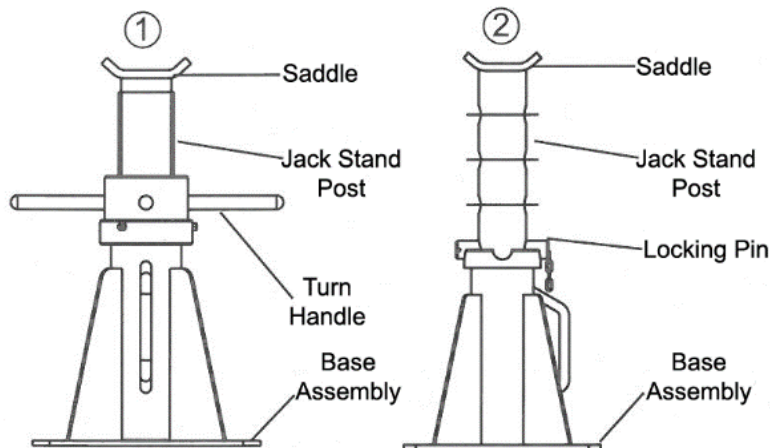

### Maintenance & Inspection

1. Visual Inspection shall be made before each use of the stands, checking for cracks, cracked welds and missing and / or damaged parts. Any stand that appears to be damaged in any way should be removed from service immediately.
2. Because of the potential hazards associated with the misuse of equipment of this type, no modifications should be made of the product without consent from manufacturer.

