



OPERATING INSTRUCTIONS & PARTS MANUAL

ALUMINUM BIROTATIONAL GEAR MOTORS

P/N'S 1821212, 1821213, 1821214, 1821215, 1821216

Concentric P/N 2690197
4/29/2013

READ CAREFULLY BEFORE ATTEMPTING TO ASSEMBLE, INSTALL, OPERATE OR MAINTAIN THE PRODUCT DESCRIBED. PROTECT YOURSELF AND OTHERS BY OBSERVING ALL SAFETY INFORMATION. FAILURE TO COMPLY WITH INSTRUCTIONS COULD RESULT IN PERSONAL INJURY AND/OR PROPERTY DAMAGE! RETAIN INSTRUCTIONS FOR FUTURE REFERENCE.

⚠ CAUTION! ⚠

These motors are built for use in either clockwise or counterclockwise rotation, as viewed from the shaft end.

NOTE: A CASE DRAIN LINE MUST BE INSTALLED CONNECTING THE CASE DRAIN PORT DIRECTLY TO THE RESERVOIR WITH NO RESTRICTIONS. DO NOT RUN THE CASE DRAIN LINE THROUGH A FILTER AS IT MAY BUILD UP BACK PRESSURE.

If used in a reciprocating application, an external relief valve is recommended.

Description

These hydraulic gear motors are of a positive displacement three-piece modular design. The motors are constructed with permanent mold grey iron (or aluminum) front and rear covers and an extruded aluminum center section which houses the external spur gear set and the pressure loaded bushing blocks. The hardened and ground one-piece gear and shaft rotate in Teflon coated steel backed bronze bushings. The bearings are installed in the precision machined bushing blocks for optimum shaft alignment. High efficiency is obtained with minimum radial tip clearance created by a specialized run-in procedure during product testing.

Unpacking

Do not remove the plastic port protectors until you are ready to connect hoses and fittings. This procedure will keep dirt or foreign material from entering the pump.

Specifications

The mounting of our hydraulic gear motors conforms to the SAE "A" two-bolt specification. The shaft also conforms to SAE shaft specifications. See Specifications sheet for further details.



Figure 1

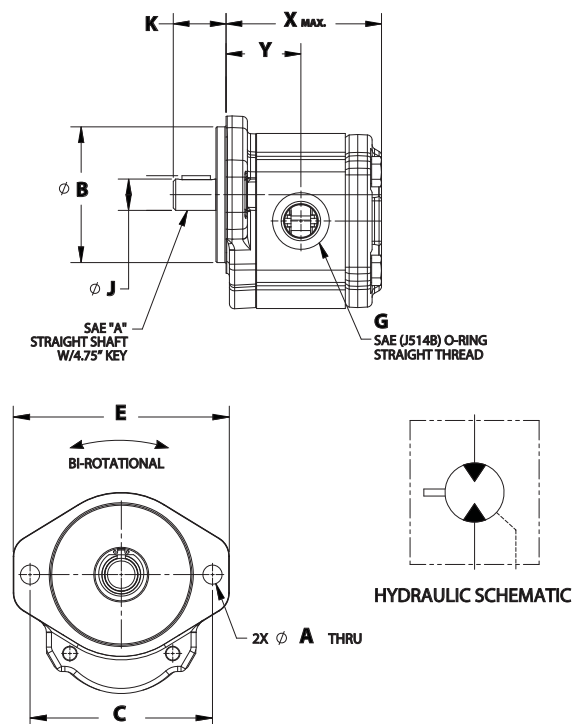

Dimensions									
P/N	A	B	C	E	G	J	K	X _{MAX.}	Y
1821212	11.25	82.5	106.4	133.0	7/8-14	19.05	32.0	95	45.5
1821213	11.25	82.5	106.4	133.0	7/8-14	19.05	32.0	100	47.8
1821214	11.25	82.5	106.4	133.0	1-1/16-12	19.05	32.0	107	51.5
1821215	11.25	82.5	106.4	133.0	1-1/16-12	19.05	32.0	112	53.7
1821216	11.25	82.5	106.4	133.0	1-5/16-12	19.05	32.0	118	56.7

General Safety Information

⚠ WARNING! ⚠

DISCONNECT POWER AND RELEASE ALL SYSTEM PRESSURE BEFORE SERVICING THIS EQUIPMENT.

1. Follow all local electrical and safety codes, as well as the National Electrical Code (NEC) and the Occupational Safety and Health Act (OSHA).
2. Never exceed the maximum operating speed or pressure.
3. When using AC motors, ground the motor properly by wiring with a grounded, metal-clad raceway system, using a separate ground wire connected to bare metal of the motor frame, or other suitable means.
4. Guard all moving parts.
5. Drain all liquids from the system before servicing.
6. Check hoses and connections for security before each use.
7. Periodically check the pump/fluid motor and system components.
8. Provide a means of pressure relief for pumps whose discharge line can be shut off or obstructed.
9. Wear safety glasses at all times when working with pumps/fluid motors.
10. Keep work area clean, uncluttered and properly lighted; replace all unused tools and equipment.
11. Keep visitors at a safe distance from the work area.
12. Make the workshop child-proof with padlocks, master switches, and by removing start keys.
13. Do not operate an engine in an enclosed area.
14. Do not spill gasoline on hot engine surfaces.
15. Store gasoline only in an approved container.
16. Keep dirty and oily cleaning rags in a tightly closed metal container.
17. Check engine oil level before operating the engine.
18. Familiarize yourself with the controls and emergency shutdown procedures.
19. Never operate the equipment when you are fatigued.
20. All system components pressure ratings should be greater than maximum system pressure.
21. Guard all moving parts.
22. Replace all guards when servicing is complete.

Assembly

Our hydraulic gear motors are packaged fully assembled and require no further assembly before installation.

1. Remove plastic shipping plugs from the inlet and outlet ports.
2. Squirt clean oil into motor for pre-lubrication and start-up.
3. Turn motor drive shaft slowly to ensure the internal parts are lubricated.
4. Install plastic shipping plugs in to inlet and outlet until hoses are installed.
5. Bolt the motor loosely to the application.
6. Make sure the motor shaft does not have a side load on it due to misalignment.
7. Tighten the mounting bolts.

8. Connect inlet, outlet, and case drain lines with an SAE straight thread fitting and tighten.

⚠ CAUTION ⚠

THREADS ARE SAE, NOT NPTF. USING INCORRECT FITTINGS COULD DAMAGE THE HYDRAULIC COMPONENT OR CAUSE PERSONAL INJURY.

NOTE: Do not use teflon tape; the O-ring provides the seal and teflon tape is not required.

9. To avoid building up pressure on the case drain and shaft seal, the outlet hose diameter should be as large as possible and outlet hose length should be as short as possible.

Note: A case drain line must be installed connecting the case drain port directly to the reservoir with no restrictions.

10. Bleed all air from the system to prevent erratic operation and ensure easy motor start up.

NOTE: Be sure adequate cooling for the hydraulic oil is provided. Excessive temperatures can cause damage to oil and/or system components. Cooling of oil is especially important on systems where continuous operation is required. Cooling requirements must be based on: duty cycle, pressure/flow, ambient temperatures, oil and component maximum temperature specifications, and reservoir capacity. Systems operating at excessively high temperatures can be hazardous and may cause property damage and/or personal injury.

NOTE: When the ambient temperature is below 32°F, allow the system pump to operate unloaded for several minutes to warm the oil in the reservoir.

Maintenance

1. Keep hydraulic fluid as clean as possible. ISO 18/14 is recommended for optimum motor life.

Use a clean funnel fitted with a fine mesh wire screen when adding fluid to the system. Do not use a cloth strainer. Motor failures can be attributed to dirt or foreign material entering the hydraulic system during filling, or lack of cleaning before filling.

- 2. Make frequent inspections of hydraulic fluid and change if contaminated.
- 3. Keep the unit clean of dirt and foreign materials.

ORDER REPLACEMENT PARTS
 BY CONTACTING NORTHERN TOOL'S Service Parts Div.

NTE MIDWEST PARTS, 2050 Airtech Road, Faribault, MN 55021
 CALL 1-507-334-9310

Please provide following information: Address parts correspondence to:

<ul style="list-style-type: none"> • Model Number • Serial Number (if any) • Part Description and Number as shown in Parts List 	ken.metz@northerntool.com
--	---------------------------

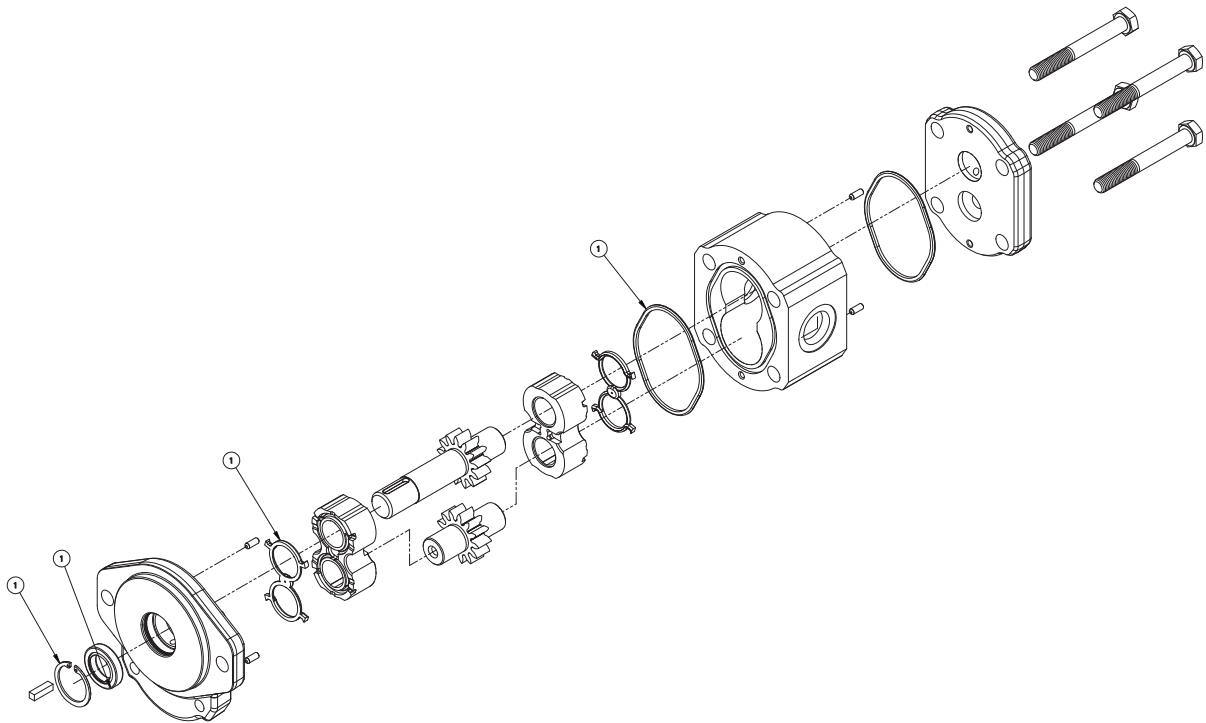

Replacement Parts List			
REF NO.	DESCRIPTION	PART NO.	QTY.
1	Seal Kit (Includes: Bi-rotational Shaft Seal Retaining Ring Bi-rotational Seals O-Rings	5000326	1

WM900 PERFORMANCE CURVES @ 100 SSU

W900 SERIES DISTRIBUTOR STOCK MOTORS												
Stock No.	Model Codes.	Displacement		Rotation	GPM @ 1800 RPM & 1000 PSI	GPM @ 3600 RPM & 1000 PSI	Max. Cont. PSI	Max. Speed, RPM	Min. Speed, RPM	Inlet Port	Outlet Port	Case* Drain
		C.I.R.	CC									
2-Bolt "A" Mount, 3/4" SAE "A" Straight Drive Shaft, and SAE Straight Thread Side Ports												
1821212	WM09A1C080B-03BA107N	0.488	8	Bi-Ro	3.73	7.45	4000	4000	500	7/8-14	7/8-14	7/16-20
1821213	WM09A1C111B-03BA107N	0.671	11	Bi-Ro	5.12	10.25	4000	3600	500	7/8-14	7/8-14	7/16-20
1821214	WM09A1C160B-03BA108N	0.976	16	Bi-Ro	7.45	14.91	4000	3000	500	1-1/16-12	1-1/16-12	7/16-20
1821215	WM09A1C190B-03BA108N	1.159	19	Bi-Ro	7.45	14.91	4000	3000	500	1-1/16-12	1-1/16-12	7/16-20
1821216	WM09A1C230B-03BA109N	1.403	23	Bi-Ro	10.71	21.43	3200	2800	500	1-5/16-12	1-5/16-12	7/16-20

* Case drain must be used. See bottom of page 5.

WM900, Input Flow vs. RPM at Max. P1 Pressure with 100 SSU Fluid

(P/N 1821212 shown)

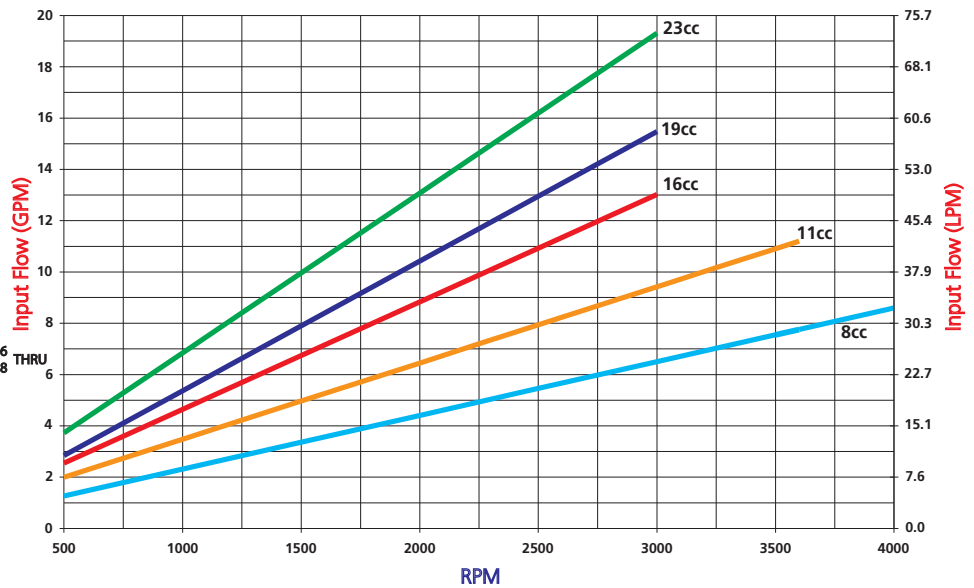
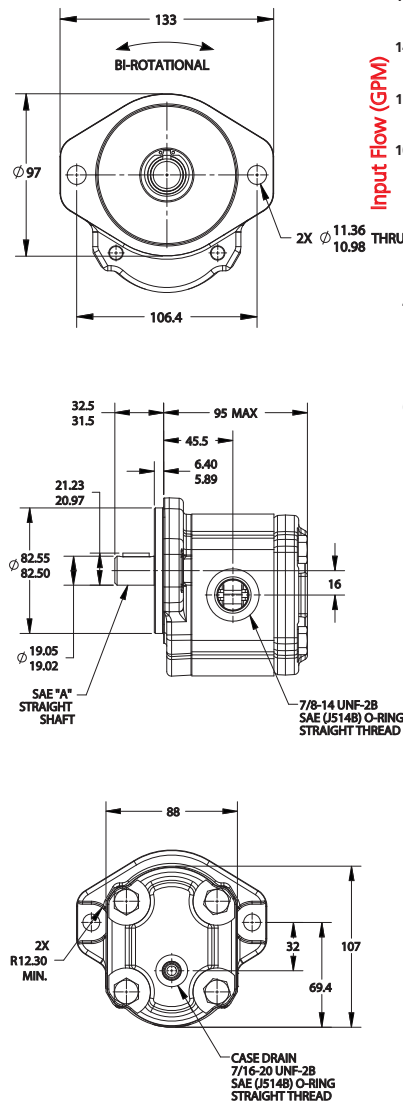

WM900, Inlet Pressure vs. Torque at Max. RPM with 100 SSU Fluid

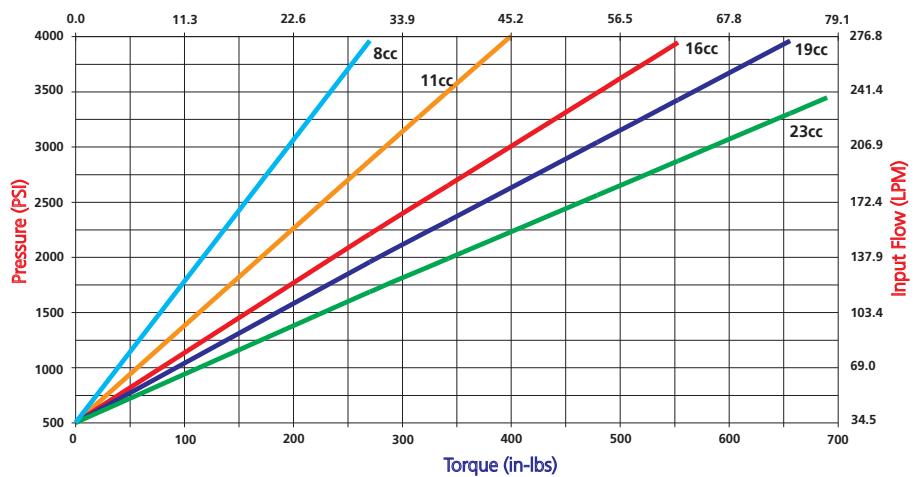

Allowable radial load and axial load at drive shaft (w/o reinforced front bearing)

The butterfly curves below show allowable radial loads based on motor location at any angle of orientation. You should not exceed the limit on the outer profile of the curve (green), based on motor location at any angle of orientation. Consult Concentric Hydraulics when using operating pressures greater than the P_S1 pressures noted in the chart below. N represents newtons.

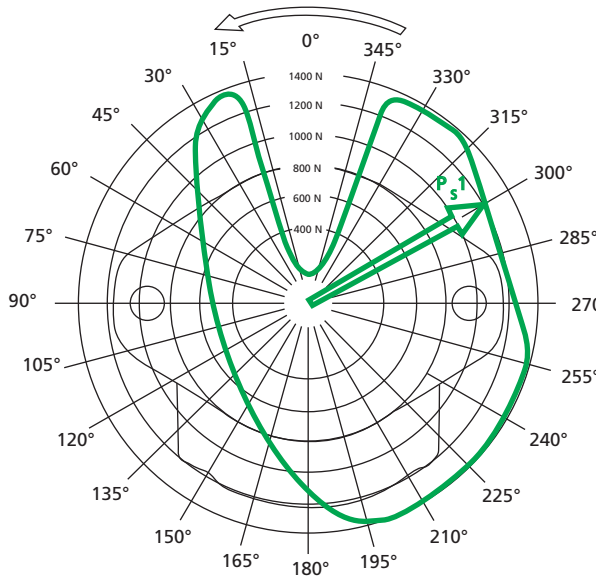

Allowable radial load P_S dependent on direction of force related to motor for counter clockwise rotation, code **L**.

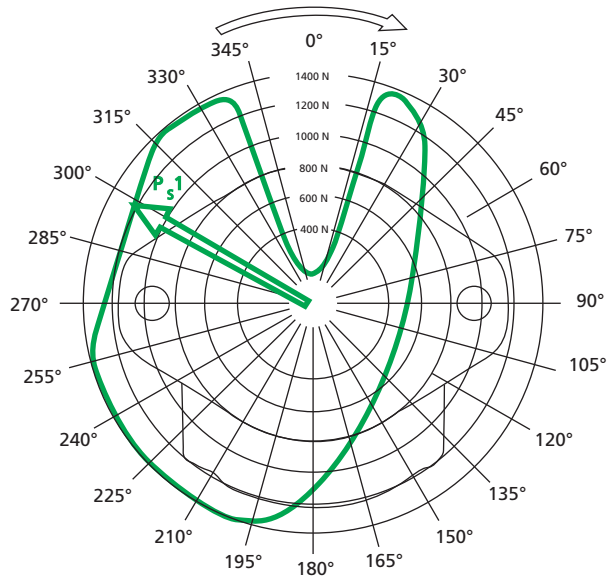

Allowable radial load P_S dependent on direction of force related to motor for counter clockwise rotation, code **R**.

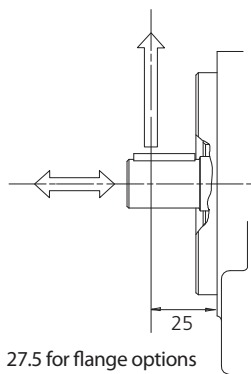

Maximum allowable axial force for both directions

$P_T = 700 \text{ Nm (6196 lbf in)}$ at viscosity of 10 cSt (59SSU).

Sum of $P_T + P_S$ does not exceed 1050 Nm (9293 lbf in) if appear simultaneously.

Radial pre-load used at V-belt drive is not permissible for fluid motors w/o reinforced front bearing.

27.5 for flange options 10/11 and 12/13.

Size	Curve PS1 < "p (bar/psi)
080 -8.0cc	276/4000
110 -11.0cc	276/4000
160 -16.0cc	200/2900
190 -19.0cc	160/2300
230 -23.0cc	160/2300

1 Newton = .224 pound-force (lbf)

400 Newtons = 89.92 pound-force (lbf)

* **CASE DRAIN MUST BE USED.** OUTLET PRESSURE ON A UNI-DIRECTIONAL MOTOR OR CASE DRAIN PRESSURE ON A BI-ROTATIONAL MOTOR MUST NOT EXCEED SEAL PRESSURE RATINGS.

Important Note: The data below shows maximum values and cannot be used concurrently, e.g. the maximum operating pressure depends on material type, shaft speed and temperature. Contact your Concentric representative for additional information.

Description	Max. Pressure PSI (BAR)		Temperature °F (°C)	
	Cont.	Inter.	Min.	Max.
High Pressure Viton	87 (6)	116 (8)	-4 (-20)	221 (105)