



# Retractable Air Hose Reel

WITH 50' AIR HOSE

## OPERATION MANUAL

SAVE THIS BOOK FOR REFERENCE

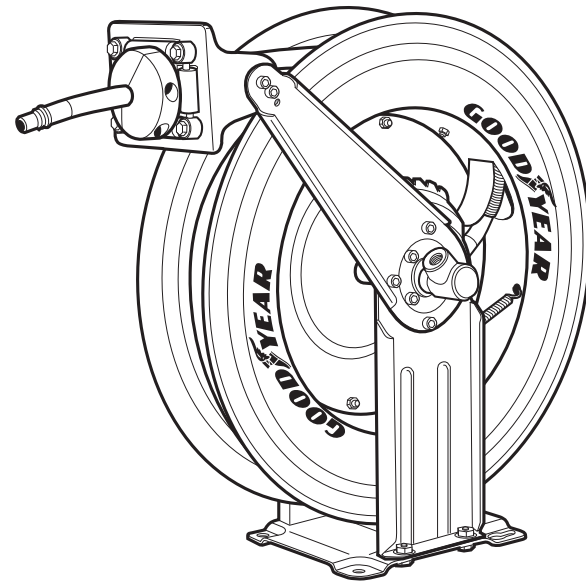

### Specifications

- Spring driven, automatic rewind, with locking ratchet mechanism (six locking positions per revolution).
- Brass connectors on hose and reel
- Air Hose Size: 3/8" x 50'
- Reel Air Inlet (F): 1/4" NPT
- Air Hose Outlet (M): 1/4" NPT
- Maximum Pressure: 250 PSI
- Maximum Air Flow: 25 CFM



Read and understand entire manual before assembling or using hose reel. Failure to follow instructions or warnings could result in personal injury and/or property damage.

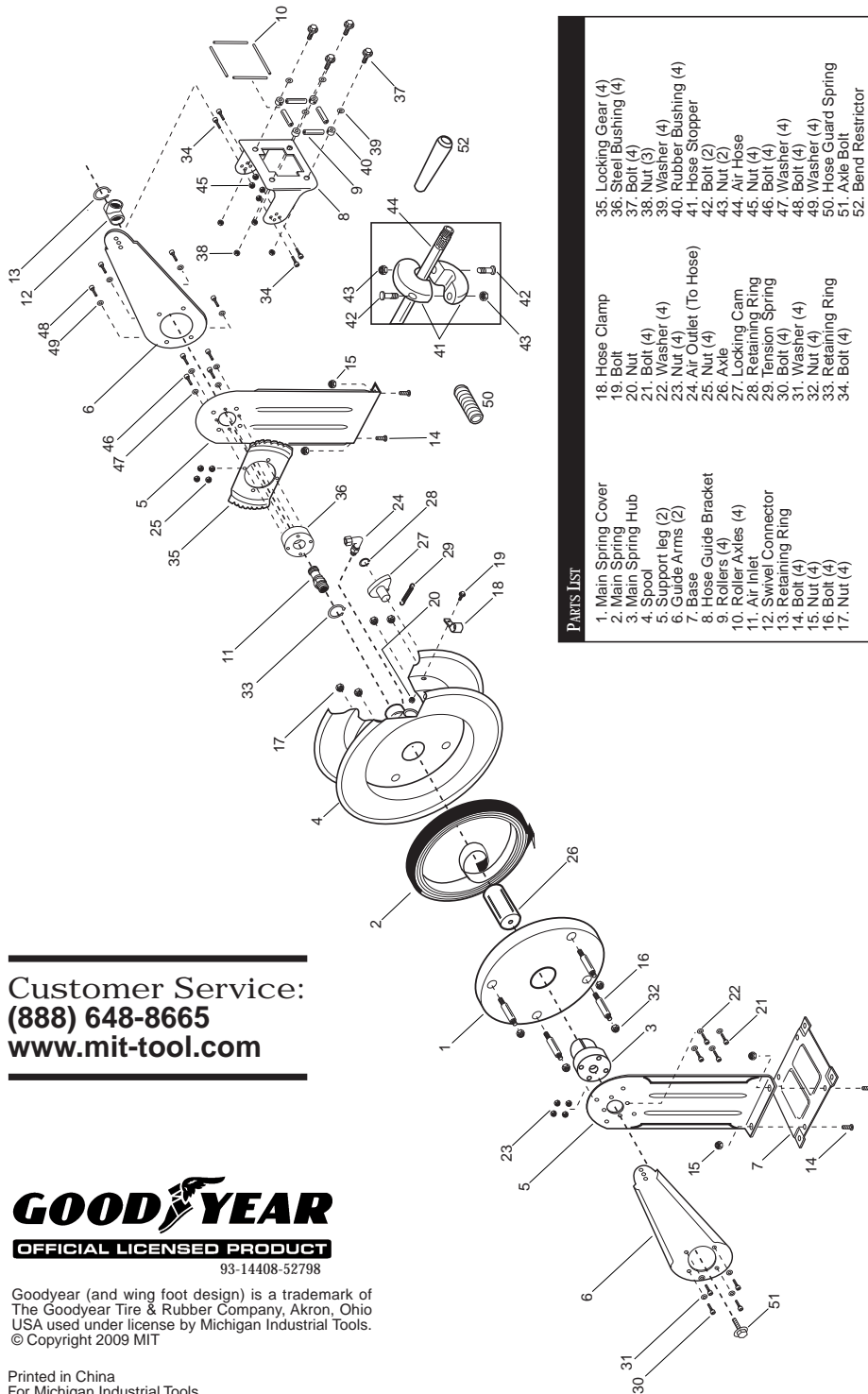

**PARTS LIST**

- |                       |                          |                        |
|-----------------------|--------------------------|------------------------|
| 1. Main Spring Cover  | 18. Hose Clamp           | 35. Locking Gear (4)   |
| 2. Main Spring        | 19. Bolt                 | 36. Steel Bushing (4)  |
| 3. Main Spring Hub    | 20. Nut                  | 37. Bolt (4)           |
| 4. Spool              | 21. Bolt (4)             | 38. Nut (3)            |
| 5. Support leg (2)    | 22. Washer (4)           | 39. Washer (4)         |
| 6. Guide Arms (2)     | 23. Nut (4)              | 40. Rubber Bushing (4) |
| 7. Base               | 24. Air Outlet (To Hose) | 41. Hose Stopper       |
| 8. Hose Guide Bracket | 25. Nut (4)              | 42. Bolt (2)           |
| 9. Rollers (4)        | 26. Axle                 | 43. Nut (2)            |
| 10. Roller Axles (4)  | 27. Locking Cam          | 44. Air Hose           |
| 11. Air Inlet         | 28. Retaining Ring       | 45. Nut (4)            |
| 12. Swivel Connector  | 29. Tension Spring       | 46. Bolt (4)           |
| 13. Retaining Ring    | 30. Bolt (4)             | 47. Washer (4)         |
| 14. Bolt (4)          | 31. Washer (4)           | 48. Bolt (4)           |
| 15. Nut (4)           | 32. Nut (4)              | 49. Washer (4)         |
| 16. Bolt (4)          | 33. Retaining Ring       | 50. Hose Guard Spring  |
| 17. Nut (4)           |                          | 51. Axle Bolt          |
|                       |                          | 52. Bend Restrictor    |

Customer Service:  
**(888) 648-8665**  
[www.mit-tool.com](http://www.mit-tool.com)



Goodyear (and wing foot design) is a trademark of The Goodyear Tire & Rubber Company, Akron, Ohio USA used under license by Michigan Industrial Tools. © Copyright 2009 MIT

Printed in China  
For Michigan Industrial Tools  
3707 Roger B. Chaffee Dr. S.E.  
Grand Rapids, MI 49548

© Copyright 2009  
Michigan Industrial Tools

## ⚠ Important Safety Rules

- DO NOT EXCEED 250 PSI incoming air pressure (from compressor).
- Wear impact-resistant eye protection that meets ANSI Spec. Z87.1 in work area at all times.
- Do not release hose when rewinding. Hold hose end and allow hose to rewind slowly.

## ⚠ CAUTION: MAIN SPRING IS UNDER HIGH TENSION

Follow instructions closely and use caution when replacing main spring, replacing hose, removing hose stopper, manually releasing locking cam, adjusting recoil tension, adjusting guide arms/hose guide bracket, or retracting hose. Failure to follow instructions may result in personal injury or physical damage to hose reel or surrounding property.

## Installing Hose Reel

*Note: Mounting hardware (four 3/8" bolts and four washers) is not included and must be purchased separately. Decide first where reel will be mounted before purchasing hardware. Different mounting positions may require additional hardware.*

### CHOOSING A MOUNTING LOCATION

Reel can be mounted on the floor, ceiling, or wall. Remember that you can only mount reel to a load-bearing structural member capable of supporting combined weight of reel, hose, and forces caused by pulling or maneuvering hose. Mounting reel near air compressor is best since you can connect the two with a shorter length of hose. Also, air compressor controls will be nearby for convenient adjusting.

⚠ **Hose reel is heavy.** Attempting to complete installation alone can be dangerous. Get help from a friend to lift and position the reel throughout the installation process. Keep both feet on firm level ground during installation. Be aware that attempting installation using a ladder can be very dangerous and is not recommended.

### CHOOSING MOUNTING POSITION

Once you have located a mounting location, consult the "Typical Mounting Positions" chart and choose the diagram that most closely matches your mounting position. If necessary, adjust position of guide arms and hose guide bracket to match diagram.

### ADJUSTING THE GUIDE ARMS AND HOSE GUIDE BRACKET

The guide arms and hose guide bracket can be adjusted for different mounting locations.

1. Pull out 3-4 feet of hose and **ensure reel spool is locked preventing retraction.**
2. Remove bolts from guide arms and/or hose guide bracket
3. Rotate guide arms and/or hose guide bracket to desired position. Replace bolts and tighten.

### MOUNTING INSTRUCTIONS

**STEP 1:** Insert two 3/8" bolts into mounting surface at 5-9/16" apart. Tighten bolts leaving 3/8" clearance between mounting surface and bottom of bolt heads to allow keyholes on hose reel base to slide over bolt heads.

**STEP 2:** With the help of a second person, lift hose reel into position and slide keyhole slots in base over bolt heads to temporarily help support reel while installing last two bolts

**STEP 3:** Insert last two bolts and washers

**STEP 4:** Tighten all 4 bolts completely

### INSTALLING HOSE

After reel is secured in position, attach air hose coming from compressor. Wrap threads of male connector on incoming air hose with thread-sealing tape (included) or apply thread sealant and connect to air inlet valve on side of hose reel. Connect other end of incoming air hose to air compressor. Apply thread-sealing tape to threads on hose before attaching air tools.

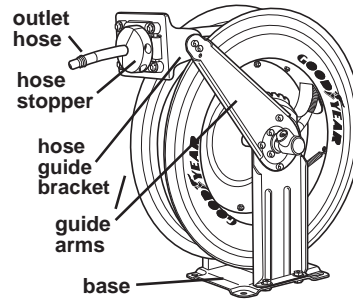

### Typical Mounting Positions

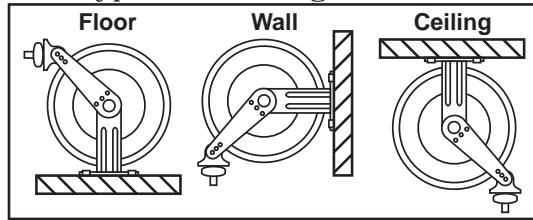

### Mounting Instructions

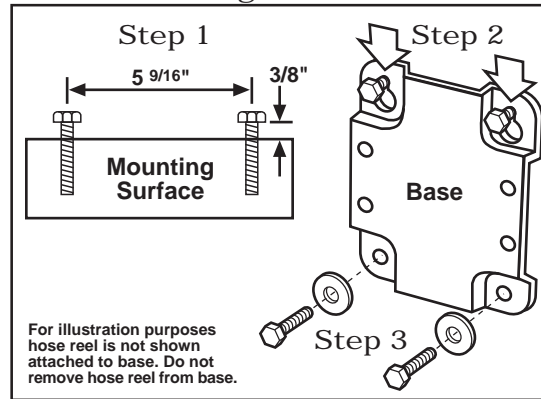

### ADJUSTING THE HOSE STOPPER

The hose stopper determines the length of hose that remains outside of reel spool. To adjust, pull hose out past desired position of hose stopper and **ensure locking cam locks reel spool in place preventing retraction.** Loosen both stopper bolts and move stopper to desired position. Tighten stopper bolts.

### Operating Hose Reel

1. Slowly pull hose from reel spool to desired length. A ratcheting mechanism inside reel makes a short series of clicking sounds every half revolution of spool.
2. **To lock** reel spool in position, listen for clicking sounds as hose is slowly pulled from spool. When locking cam clicks, stop pulling hose. Decrease tension on hose and reel spool will lock in position.
3. **To retract** hose onto spool, slowly pull out hose until series of clicking sounds stops (1/8 revolution). **DO NOT LET GO OF HOSE!** Allow hose to retract slowly until hose stopper rests against hose guide.
4. Periodically check the hose for excessive wear and hose connections for air leaks.

### Maintaining Hose Reel

*Refer to parts diagram on back page for part numbers*

### ADJUSTING RECOIL TENSION

1. Disconnect incoming air supply.
2. Pull out about 2 feet of hose and ensure locking cam locks reel spool in place preventing retraction.
3. Remove (2) nuts (part 43) and (2) bolts (part 42) from hose stopper (part 41) then remove hose stopper from air hose (part 44).
4. **While firmly holding onto edge of reel spool**, unlatch locking cam and carefully allow spool to slowly rewind, drawing hose end back through hose guide bracket roller assembly and onto spool. Latch reel spool in position.
5. **To Increase Tension:** Unlatch reel spool and turn counterclockwise (as viewed from air inlet side). **To Decrease Tension:** Unlatch and allow reel spool to rotate slowly clockwise (as viewed from air inlet side).
6. Once desired spring tension is reached, latch spool in position. Feed hose end through roller assembly in hose guide bracket and re-attach hose stopper.
7. Re-connect incoming air supply.

### REPLACING AIR INLET VALVE O-RINGS

1. Disconnect incoming air supply and inlet-end of hose from brass air inlet valve.
2. Remove retaining ring (part 13) and slide air inlet valve swivel collar (part 12) off from air inlet valve body (part 11).
3. Remove (2) worn O-rings from air inlet (part 11) and replace with new parts.
4. Reverse above procedure to re-assemble.

### REPLACING HOSE

1. Secure and stabilize reel. In most cases, hose can be replaced with reel still mounted.
2. Disconnect incoming air supply.
3. Pull out entire length of hose and lock spool. **Make sure spool is securely locked in place.**
4. Unscrew hose clamp (part 18) that secures hose to spool. Disconnect inlet-end of hose from air outlet valve (part 24).
5. Pull inlet-end of hose through slot in spool and hose guide bracket rollers, removing old hose completely.
6. Remove hose guard spring (part 50), hose clamp (part 18) and hose stopper (part 41) from old hose. Fit these parts on new hose in identical positions.
7. Feed inlet-end of hose through hose guide bracket (part 8) and slot in spool.
8. Apply thread-sealing tape or thread sealant to hose connector and connect to air outlet valve.
9. Attach hose clamp to spool. Rewind hose onto spool using normal operation.

### REPLACING SPRING

1. Follow steps 1-3 under "Adjusting Recoil Tension" above.
2. **While firmly holding onto edge of spool**, unlatch locking cam and carefully allow spool to slowly rewind until tension in spring is relieved and spool stops. **Spring tension MUST be completely relieved or main spring could cause injury or damage when spring cover is removed.**
3. Remove hose reel from mounting location and lay hose reel on work surface with air inlet side facing down. Remove support leg and guide arm assembly (parts 5,6,14,15,21,22,23,30,31,34,45,51) from spring cover side of reel only. Do not remove any parts from air inlet side of reel.
4. Carefully remove main spring hub (part 3) by pulling straight out.
5. Remove (4) nuts (part 32) pull spring cover (part 1) off and remove worn main spring (part 2).
6. Place main spring hub (part 3) through center of main spring cover (part 1) and place both down on work surface with inside facing up.
7. Fit new main spring center over main spring hub (part 3) and ensure main spring hook is in correct position to engage hook on inside of main spring cover. Apply new grease if needed.
8. Hold main spring cover, hub, and spring together and fit back into reel spool.
9. Reverse steps 1-5 above to re-assemble.