



M4051101A.1

ITEM NUMBER: 4051101, 4051111,
4051121, 4051131,
4051141, 4051151

SERIAL NUMBER: _____

Owner's Manual

3, 5, 7, 10, 12, and 20 gallon hydraulic reservoirs

WARNING

This product contains chemicals known to the State of California to cause cancer and birth defects or other reproductive harm.

STOP!

FLUSH TANK BEFORE USING: Minor scaling or debris may be present inside the tank due to the manufacturing process. It is recommended that the reservoir be flushed or rinsed out and allowed to dry prior to use or installation.

INSPECT COMPONENTS: Closely inspect to make sure tank, breather cap, drain plug and oil gauge are not damaged or missing. If you have damaged components, contact the Freight Company that delivered the unit and file a claim. If you have missing components, contact Customer Service at 1-800-521-0438.

WARNING

READ and UNDERSTAND this information completely before using hydraulic reservoir.

All operators of this equipment must read and completely understand all safety information and usage instructions. Failure to comply with this information could result in serious injury to the operator and bystanders or damage to equipment.

Do Not use this unit in applications where more than 75% of the hydraulic fluid is purged from the hydraulic reservoir or with a cylinder storing a larger oil reserve than the hydraulic reservoir.

Do Not attempt to add more hydraulic fluid during operation to extend the hydraulic capacity.

Ensure all components in the hydraulic system are appropriately sized and rated for the application.

Do Not touch the exterior of the reservoir. It can become hot during operation.

ALWAYS keep a fire extinguisher rated "ABC" nearby.

High Pressure Hydraulic Fluid Hazards

Check the hydraulic system (hoses, tubing, clamps/fittings, pump, and cylinders) carefully before each use. Do not operate the hydraulic system with frayed, kinked, cracked, or damaged hydraulic hoses, fittings, or tubing, or if oily residue is observed on any of the components. High fluid pressures and temperatures are developed in hydraulic equipment. Hydraulic fluid escaping through a pinhole sized opening can burn or puncture skin, resulting in wounds that could cause blood poisoning, infection, disability, gangrene, amputation, or death. Therefore, the following instructions should be heeded at all times when inspecting or servicing hydraulic equipment.

- Always make sure the engine/motor is off before servicing the hydraulic system. In addition, disconnect spark plug/power supply and relieve system pressure *before changing or adjusting hydraulic system components* such as hoses, tubing, fittings, or other components.
- **Never remove the hydraulic fill cap while in operation.** Hot oil can escape, causing severe burns. Allow hydraulic system to cool completely before removing hydraulic oil fill cap.
- **NEVER check for leaks with your hand.** Leaks can be located by holding a piece of cardboard or wood (at least two feet long) with your hand at one end and passing the other end over the suspected area (wear eye protection). Look for discoloration of the cardboard or wood.
- If injured by escaping fluid, no matter how small the wound is, see a doctor at once. A typical injection injury may be a small wound that does not look serious. However, severe infection or reaction can result if proper medical treatment is not administered immediately by a doctor who is familiar with injection injuries.

Summary of Safety Information

WARNING

Never remove the hydraulic fill cap while in operation. Hot oil can escape causing severe burns.

Allow the hydraulic system to cool completely before removing the hydraulic cap.

Do not touch the exterior of the reservoir. It can become hot during operation.

Relieve system pressure before changing or adjusting hydraulic system components.

Ensure all components in the hydraulic system are appropriately sized and rated for the application.

Check the hydraulic system (hoses, tubing, clamps/fittings, pump and cylinder carefully before each use.

Do not operate the hydraulic system or its attachments with frayed, kinked, cracked or damaged hydraulic hoses, fittings or tubing.

Do not attempt to add more hydraulic fluid during operation to extend the hydraulic capacity.

READ and UNDERSTAND the Owner's Manual completely before using the Hydraulic Reservoir.

Use only in accordance with the Owner's manual instruction.

Replace this label if damaged or destroyed. Consult Owner's Manual for ordering instructions.

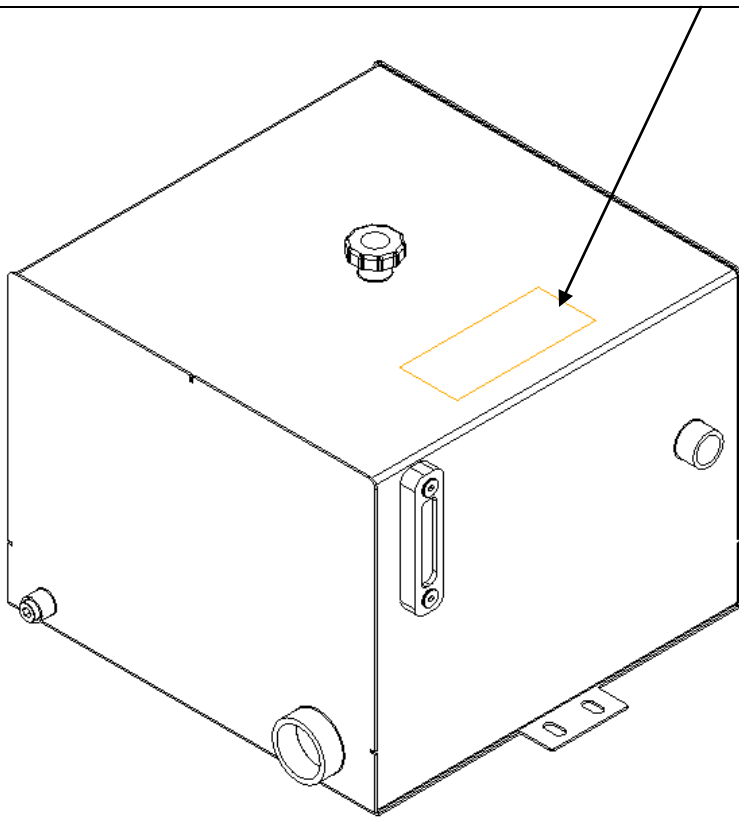

Always make sure safety label is in place and in good condition. If the safety label is missing or not legible, order new a new label or unsafe operation could result.

To order replacement safety label, call NorTrac Product Support at 1-800-521-0438.

Unpacking the Manual Bag

Note: Items in this section are found in the manual bag.

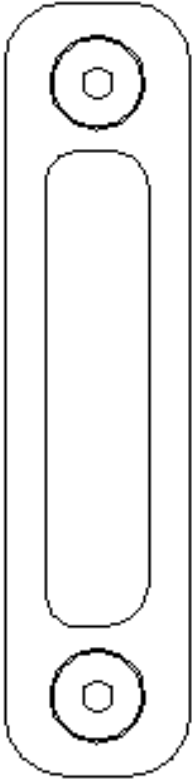

Sight Level
Oil Gauge
w/Thermometer
Qty: 1
#4066

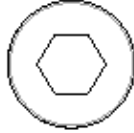

Magnetic Drain Plug
Qty: 1
#790064

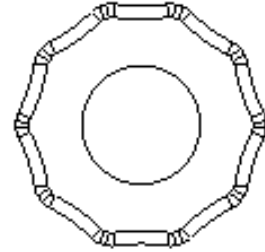

Threaded Breather Cap
Qty: 1
#784456

Reservoir Assembly

Step 1 – Install Breather Cap

Rotate cap clockwise to seal reservoir.

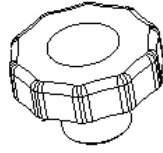

Step 2 – Insert Magnetic Drain Plug.

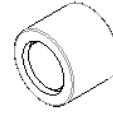

Tighten With
3/8" Hex Wrench

Step 3 – Assemble Sight Level Oil Gauge/Thermometer to Reservoir as shown using a 6mm Hex Wrench.

Torque Bolts to 2-4 FT LBS. (24-48 IN LBS.)

Do Not Overtighten

Notes: Make sure Small gasket is pushed up to bolt head.
Large T-gasket is flat against the reservoir.
Text should be right side up.

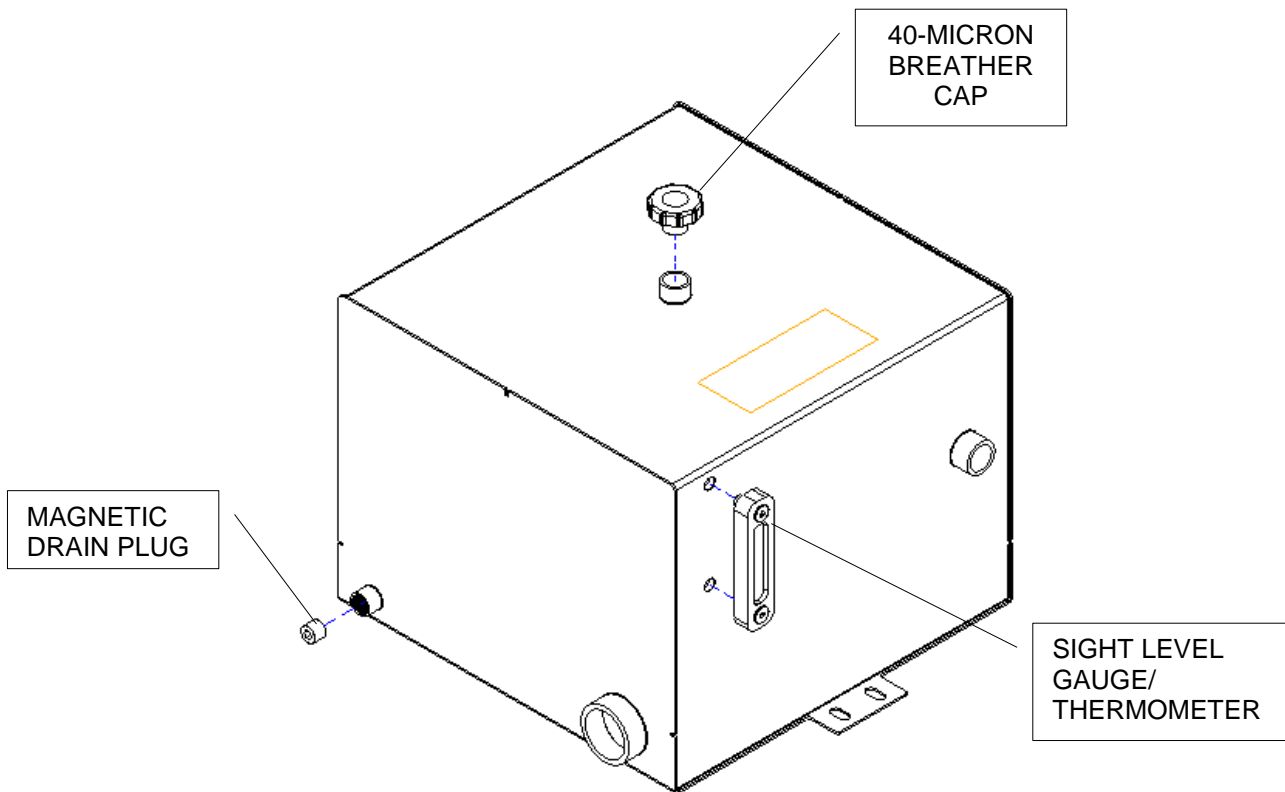
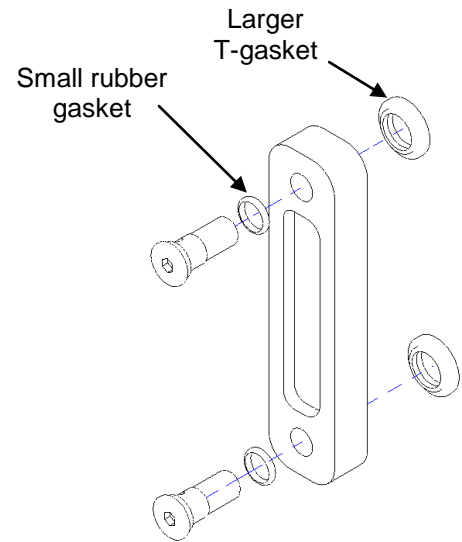

Reservoir Specifications

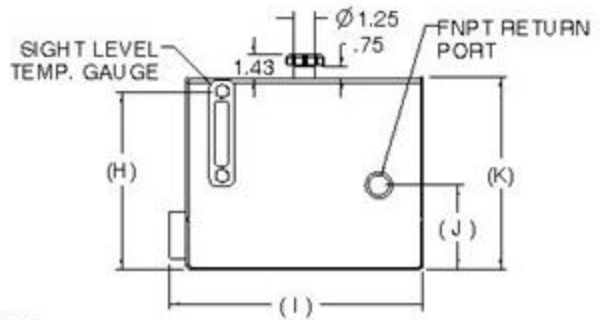
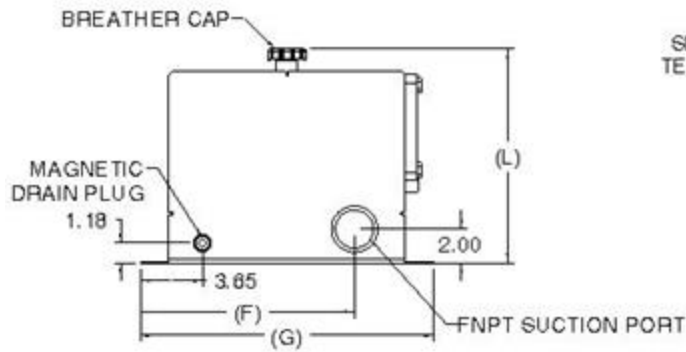
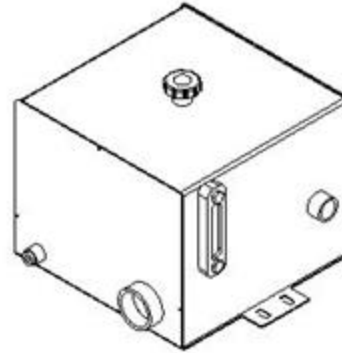
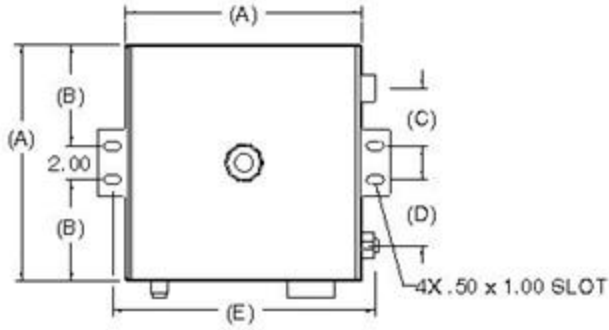

PART NUMBER	4051101	4051111	4051121	4051131	4051141	4051151
CAPACITY (GALLONS)	3	5	7	10	12	20
A	11.30"	13.30"	13.98"	15.72"	17.00"	19.21"
B	4.65"	5.65"	5.99"	6.86"	7.50"	8.60"
C	2.04"	3.04"	3.38"	4.25"	4.89"	5.99"
D	2.54"	3.54"	3.88"	4.75"	5.39"	6.49"
E	12.85"	14.85"	15.53"	17.27"	18.55"	20.76"
F	9.95"	11.95"	12.63"	12.50"	15.65"	17.86"
G	14.60"	16.60"	17.28"	19.02"	20.30"	22.51"
H	7.39"	8.66"	10.51"	11.51"	11.76"	14.26"
I	12.30"	14.30"	14.98"	16.72"	18.00"	20.21"
J	2.09"	3.21"	4.96"	6.46"	6.35"	8.76"
K	8.46"	9.71"	11.34"	12.46"	12.63"	15.21"
L	9.78"	11.03"	12.65"	13.78"	13.92"	16.53"
RETURN PORT	3/4" FNPT	3/4" FNPT	1" FNPT	1" FNPT	1" FNPT	1" FNPT
SUCTION PORT	1-1/2" FNPT	1-1/2" FNPT	2" FNPT	2" FNPT	2" FNPT	2" FNPT
TWIST-ON BREATHER CAP PART# 784456						
OPTIONAL ACCESSORY: SMALL SUCTION STRAINER FITS 1-1/2" PORT PART# 778644			OPTIONAL ACCESSORY: LARGE SUCTION STRAINER FITS 2" PORT PART#778639			

Any Questions, Comments, Problems or Parts Orders
Call Customer Service at 1-800-521-0438

Limited Warranty

Dear Valued Customer:

The NorTrac Product you just purchased is built with the finest material and craftsmanship. Use this product properly and enjoy the benefits from its high performance. By purchasing a NorTrac product, you show a desire for quality and durability. Like all mechanical equipment this unit requires a due amount of care. Treat this unit like the high quality piece of machinery it is. Neglect and improper handling may impair its performance. Please thoroughly read the instructions and understand the operation before using your product.

NorTrac shall warranty any piece of equipment manufactured, or parts of equipment manufactured, to be free from defects in material or workmanship for a period of 90 days for consumer/commercial use from the date of purchase by user.

NorTrac shall warranty any wear item, including, but not limited to, valves, seals, pump diaphragms, hoses, and filter elements to be free from defects in material or workmanship for a period of 90 days from the date of purchase by user. This warranty applies to the original purchaser of the equipment and is nontransferable. Verification of purchase is the responsibility of the buyer. Parts will be replaced or repaired at no charge, except when the equipment has failed due to lack of proper maintenance. Any misuse, abuse, alteration or improper installation or operations will void warranty. Determining whether a part is to be replaced or repaired is the sole decision of NorTrac.

NOTE: Some services performed by parties other than NorTrac may void warranty.

This warranty covers parts only. It will not provide for replacement of complete products due to defective parts. Components not manufactured by NorTrac are guaranteed by their manufacturer and can be serviced at factory-authorized locations near you. Any costs incurred due to replacement or repair of items outside of a NorTrac approved facility is the responsibility of the buyer and not covered under warranty. NorTrac can supply you with the service center location in your area.

This warranty specifically excludes the following; failure of parts due to damage caused by accident, fire, flood, windstorm, acts of God, applications not approved by NorTrac in writing, corrosion caused by chemicals, use of replacement parts which do not conform to manufacturer's specifications, and damage caused by vandalism. Additional exclusions: loss of running time, inconvenience, loss of income, or loss of use, including any implied warranty of merchantability of fitness for a specific use.

Warranty does not cover items subject to normal wear such as tires, receptacles or any part subject to direct physical contact by the public. This warranty does not cover any personal injury or damage to surrounding property caused by failure of any part.

This warranty is in lieu of any other warranty expressed or implied and NorTrac assumes no other responsibility or liability outside that expressed within this warranty.

Please fill in the following information and have it on hand when you call in on a warranty claim.

Customer Number: _____

Date of Purchase: _____

NorTrac Serial Number: _____

Item Number: _____

This page has intentionally been left blank.



Manufactured by
Northern Tool + Equipment Co., Inc.
2800 Southcross Drive West
P.O. Box 1499 Burnsville, MN 55337-0499
Made in the USA