

Cumberland Float Tube Critical Dimensions

11/17/2008

Revised 05/20/09

Page 3 of 28

Model	A	B	C	D	E	F
All	56.00	44.00	19.00	19.25	42.50	4.50

NOTE: Measurements taken on a fully inflated float tube

- A. Overall length
- B. Overall width at front
- C. Height at center back
- D. Tube circumference at CB
- E. Tube circumference at front of pocket
- F. Height from bottom of tube to seat bottom (inflated tube)

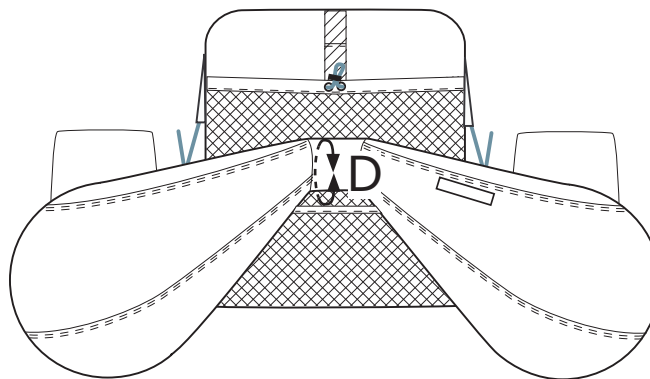
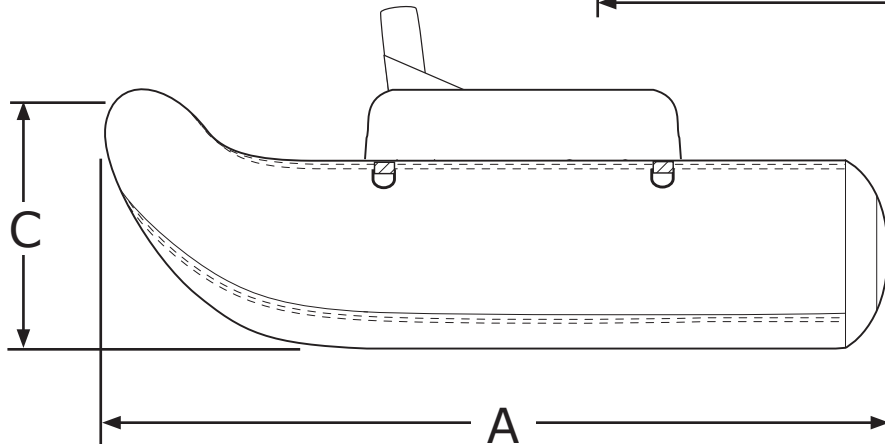
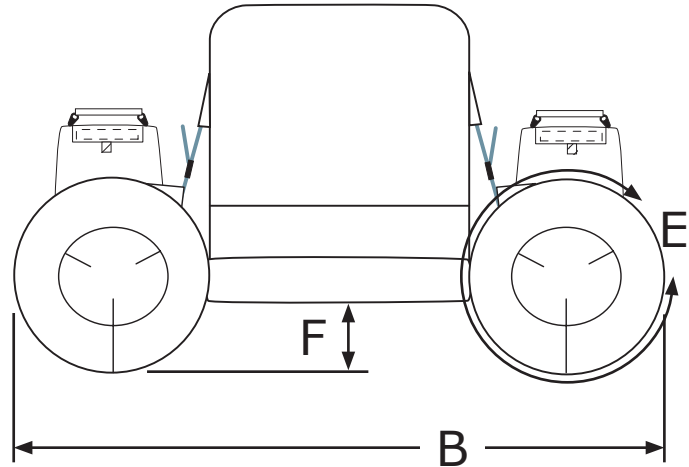

Part #

32-001-011101-00
32-031-011103-11
32-001-011101-KR

Plus/Minus Tolerances

0 - 12"	+/- 0.125" max
13 - 24"	+/- 0.25" max
25 - 48"	+/- 0.50" max
49" and over	+/- 0.75" max

Please Note:
All Dimensions
are In Inches
Unless Noted
Otherwise