

RP-10 Rotary Hand Pump for Fuel and Petroleum

Owner's Manual



STOP

**DO NOT RETURN
THIS PRODUCT
TO THE STORE!**

Please contact GPI before returning any product. If you are missing parts or experience problems with your installation, our Customer Support Department will be happy to assist you.

GPI Customer Support
800-835-0113 or
316-686-7361

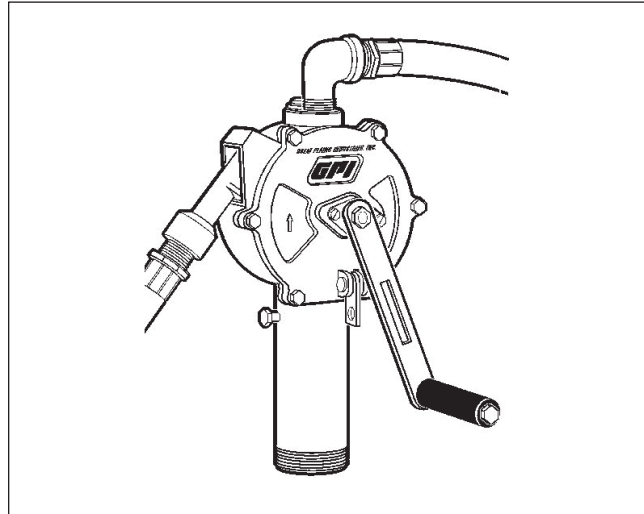

WARNING

This product shall not be used for pumping fuel or other liquids into aircraft.

GENERAL INFORMATION

The RP-10 Rotary Hand pump is designed for use with gasoline (up to 15% alcohol blends such as E15), diesel fuel (up to 20% biodiesel blends such as B20), kerosene and up to medium weight oils. These self-priming pumps deliver up to 10 gallons (38 litres) per 100 revolutions and are designed for use on a tank with a 2-inch bung. They are equipped with an anti-siphon vent to prevent possible tank siphoning. Do not use the RP-10 pump with chemicals.

Safety Instructions

Observe standard safety precautions when handling fuel.

- Keep away from open flame or spark.
- Do not refuel vehicles or equipment with engines running or while equipment engine is hot.
- Do not smoke while refueling.

INSTALLATION

Before installation, clean the tank interior of dirt and foreign material. Wrap all threads that are exposed to liquids with 3 to 4 turns of Teflon® tape or a thread-sealing compound approved for use with petroleum fuels. Remove protective covers and plugs.

1. Hand-tighten the riser on to the tank bung.
2. Your pump is supplied with a molded seal to form an environmental seal between the pump body and the riser. Install the seal onto the top lip of the riser.
3. Assemble the crank and handle. Then snugly tighten the crank onto the shaft. Reference the Illustrated Parts Drawing for details.
4. Screw the suction pipe into the pump inlet.
5. Extend the suction pipe to its full length. Insert it through the riser and into the tank. Adjust the suction pipe to the length needed to rest on the tank bottom. If tank debris is a potential problem, raise the end of the suction pipe 2 to 3 inches.
6. Secure the pump onto the riser with the two set screws. Tighten until snug.

To install the hose and nozzle, thread the elbow fitting into the pump outlet and tighten until snug. Hand-tighten the hose into the elbow until snug. Tighten the nozzle onto the hose fitting. Insert the nozzle into the hanger.

OPERATIONS

To dispense fuel, remove the nozzle from its hanger and insert into a tank. Pump fuel by rotating the crank in the direction of the arrow on the housing. After dispensing fuel, drain the hose and replace the nozzle in the hanger.

During daily use, this pump is essentially maintenance free. However, the pump should be inspected periodically for signs of leakage. If leaks are present or other problems occur, refer to the Troubleshooting Section.

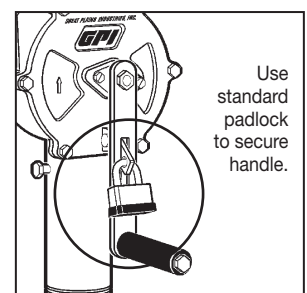

SPECIFICATIONS

The Rotary Hand Pump is compatible with gasoline (up to 15% alcohol blends such as E15), diesel fuel (up to 20% biodiesel blends such as B20), kerosene and up to medium weight oils.

Construction:	Lightweight, die-cast aluminum housing. Stainless steel shaft. Nitrile seals. Cast iron rotor and carbon vanes. Built-in anti-siphon vent.
Pumping Capacity:	Up to 10 gallons (38 litres) per 100 revolutions
Inlet:	1-inch NPT female
Outlet:	3/4-inch NPT female
Shipping Weight:	17 lbs. (7.7 kg)
Hose and Nozzle:	3/4-inch x 8 foot (2.4m) Buna-N statically grounded hose. Aluminum Alloy unleaded nozzle
Suction Pipe:	Plastic, adjustable from 22 to 40 inches (55 to 102cm)

PARTS AND SERVICE

For warranty consideration, parts or other service information, please contact your local distributor or the GPI Customer Service Department, during normal business hours at:

1-800-835-0113

To obtain prompt, efficient service, be prepared with:

- the model number of your pump
- the serial number or manufacturing date code of your pump, and
- parts descriptions and numbers

Reference the Illustrated Parts List for specifics on parts. For warranty service, be prepared with your original sales slip or other evidence of purchase date.

CAUTION

Do not return the pump without specific authority from the GPI Customer Service Department. Due to strict regulations governing transportation, handling, and disposal of hazardous or flammable liquids, GPI will not accept pumps for rework unless they are completely free of liquid residue.

TROUBLESHOOTING

SYMPTOM	PROBABLE CAUSE	CORRECTIVE ACTION
A. FLUID LEAKS AROUND SHAFT	<ol style="list-style-type: none"> 1. Retainer loose 2. O-ring worn 	<p>Tighten retainer screws.</p> <p>Check shaft O-ring for excessive wear. Replace Shaft Seal O-ring, if necessary.</p>
B. FLUID LEAKS AT ANTI-SIPHON VENT	<ol style="list-style-type: none"> 1. Anti-siphon vent or O-ring damaged 	<p>Remove vent cap. Loosen vent by turning counterclockwise. Remove vent and O-ring. Clean. To replace, seat O-ring on vent and screw vent into place until bottomed out. Replace vent cap.</p>
C. LOW FLOWRATE	<ol style="list-style-type: none"> 1. Internal parts worn or debris in vane cavity 2. Vanes cracked 	<p>Remove coverplate and inspect for wear on vanes, coverplate, and all inside housing surfaces. Replace any scored parts.</p> <p>Remove coverplate and inspect for chips or cracks on vanes. If necessary, replace vanes.</p>
D. PUMP FAILS TO PUMP	<ol style="list-style-type: none"> 1. Suction pipe leak 2. Internal parts worn or debris in vane cavity 3. Vanes cracked 	<p>Remove pump from riser. Inspect the suction pipe for wear or damage. Replace, as necessary, and install pump on tank.</p> <p>Remove coverplate and inspect for wear on vanes, coverplate, and all inside housing surfaces. Replace any scored parts.</p> <p>Remove coverplate and inspect for chips or cracks on vanes. If necessary, install Overhaul Kit or replace vanes.</p>
E. HANDLE TURNS HARD OR PUMP SEIZED	<ol style="list-style-type: none"> 1. Debris in vane cavity 2. Internal parts worn 	<p>Remove pump from tank. Remove coverplate and inspect for debris in cavity. Clean cavity, vanes, and rotor. Flush contamination from tank. Assemble and install pump.</p> <p>Remove pump from tank. Remove coverplate and inspect for damaged necessary, install Overhaul Kit or replace vanes.</p>
F. VANES STICKING	<ol style="list-style-type: none"> 1. Debris in vane cavity 	<p>Remove coverplate. Use emery cloth to remove debris or corrosion in vane slots. Apply lubricant (WD-40®) if needed.</p>

ILLUSTRATED PARTS LIST

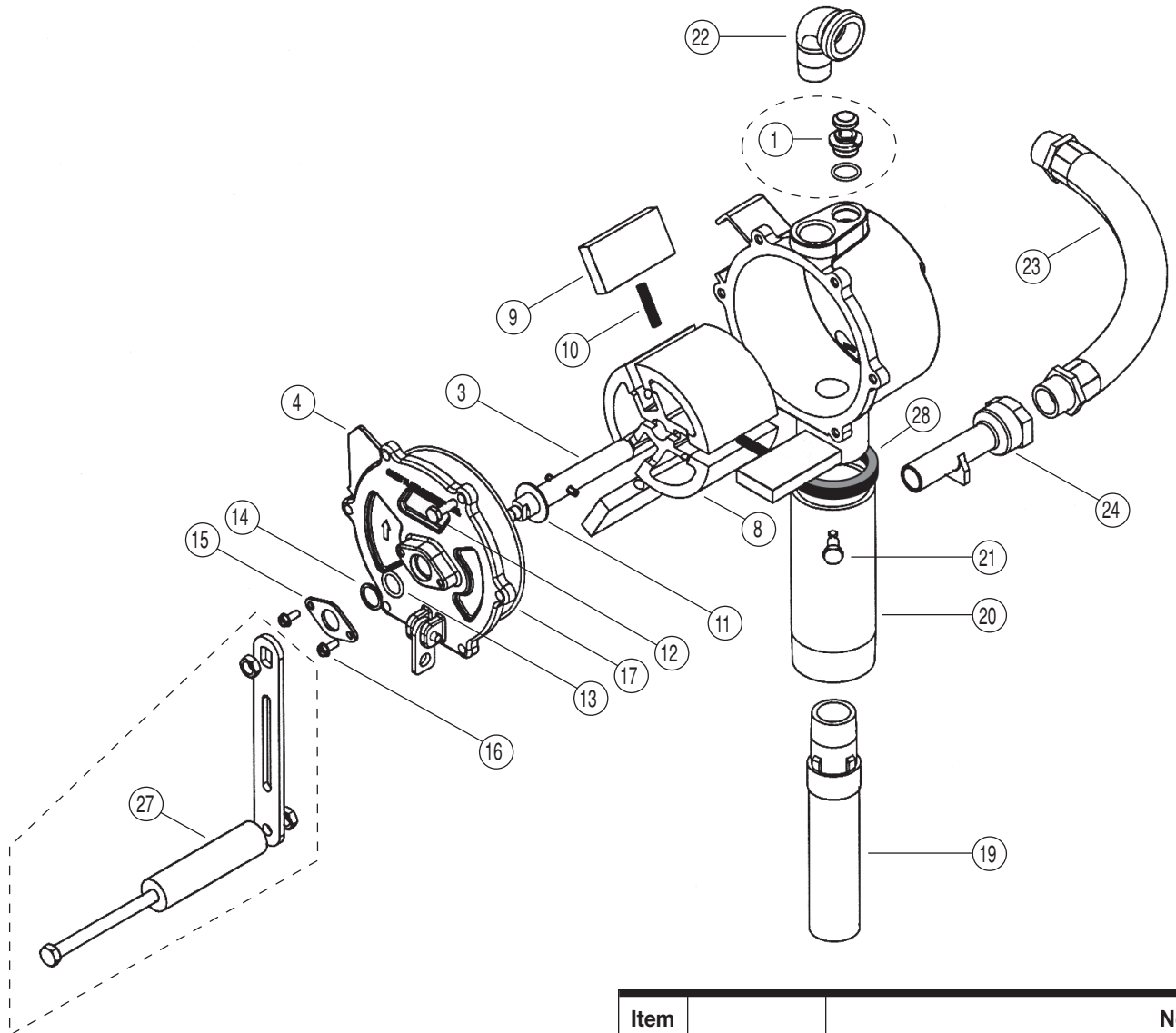

Kits and Accessories

- A** 123501-1 Shaft Seal Kit includes O-ring, back-up ring, and seal.
- B** 123503-1 Overhaul Kit includes vanes, springs, and Shaft Seal Kit.
- 123505-3 Hardware Kit
- 115527-2 Suction Pipe Extension, 15 inches or 38.1cm.

Item No.	Part No.	Description	No. Req'd.
1	123504-1	Anti-Siphon Vent Kit	1
3	123507-1	Shaft Assembly Kit	1
4	123008-1	Coverplate	1
8	123509-1	Rotor with Springs Kit	1
9	123011-1	Vane or (Kit B)	3
10	123012-1	Spring or (Kit B).....	3
11	904004-71	Washer.....	1
12	904004-16	Screw, 1/4-20 x 3/4".....	6
13	901003-63	O-Ring or (Kit A or B)	1
14	901002-58	Back-up Ring or (Kit A or B).....	1
15	123013-1	Retainer	1
16	904004-60	Retainer Screws	2
17	901003-64	O-Ring or (Kit A).....	1
19	110100-1	Suction Pipe Assembly.....	1
20	123015-1	Riser	1
21	904004-59	Set Screws	2
22	904004-73	Elbow Fitting.....	1
23	114045-1	Hose Assembly.....	1
24	114047-1	Metal Nozzle.....	1
	114036-1	Plastic Nozzle.....	1
27	123506-1	Crank Assembly Kit.....	1
28	12304001	Seal, RP-10 Riser	1

Limited Warranty Policy

Great Plains Industries, Inc. 5252 E. 36th Street North, Wichita, KS USA 67220-3205, hereby provides a limited warranty against defects in material and workmanship on all products manufactured by Great Plains Industries, Inc. This product includes a 2 year warranty from date of purchase as evidenced by the original sales receipt. A 30 month warranty from product date of manufacture will apply in cases where the original sales receipt is not available. Reference product labeling for the warranty expiration date based on 30 months from date of manufacture. Manufacturer's sole obligation under the foregoing warranties will be limited to either, at Manufacturer's option, replacing or repairing defective Goods (subject to limitations hereinafter provided) or refunding the purchase price for such Goods theretofore paid by the Buyer, and Buyer's exclusive remedy for breach of any such warranties will be enforcement of such obligations of Manufacturer. The warranty shall extend to the purchaser of this product and to any person to whom such product is transferred during the warranty period.

This warranty shall not apply if:

- A. the product has been altered or modified outside the warrantor's duly appointed representative;
- B. the product has been subjected to neglect, misuse, abuse or damage or has been installed or operated other than in accordance with the manufacturer's operating instructions.

To make a claim against this warranty, contact the GPI Customer Service Department at 316-686-7361 or 800-835-0113. Or by mail at:
Great Plains Industries, Inc.
5252 E. 36th St. North
Wichita, KS, USA 67220-3205

GPI will step you through a product troubleshooting process to determine appropriate corrective actions.

GREAT PLAINS INDUSTRIES, INC., EXCLUDES LIABILITY UNDER THIS WARRANTY FOR DIRECT, INDIRECT, INCIDENTAL AND CONSEQUENTIAL DAMAGES INCURRED IN THE USE OR LOSS OF USE OF THE PRODUCT WARRANTED HEREUNDER.

The company herewith expressly disclaims any warranty of merchantability or fitness for any particular purpose other than for which it was designed.

This warranty gives you specific rights and you may also have other rights which vary from U.S. state to U.S. state.

Note: In compliance with MAGNUSON MOSS CONSUMER WARRANTY ACT – Part 702 (governs the resale availability of the warranty terms).



5252 East 36th Street North
Wichita, KS USA 67220-3205
TEL: 316-686-7361
FAX: 316-686-6746

GREAT PLAINS INDUSTRIES, INC.

"A Great Plains Ventures Subsidiary"

www.gpi.net

1-800-835-0113



GPI is a registered trademark of Great Plains Industries, Inc.
© 2009 by GREAT PLAINS INDUSTRIES, INC., Wichita, KS

Printed in U.S.A.

04/09

Rev. - 921462-07