

JET[®]

Operating Instructions and Parts Manual 8-in x 13-in Horizontal Cut-Off Bandsaw Model: J-7015



WALTER MEIER (Manufacturing) Inc.
427 New Sanford Road
LaVergne, Tennessee 37086
Ph.: 800-274-6848
www.waltermeier.com

Part No. M-414450
Revision B 03/2012
Copyright © 2012 Walter Meier (Manufacturing) Inc.

Warranty and Service

Walter Meier (Manufacturing) Inc., warrants every product it sells. If one of our tools needs service or repair, one of our Authorized Service Centers located throughout the United States can give you quick service. In most cases, any of these Walter Meier Authorized Service Centers can authorize warranty repair, assist you in obtaining parts, or perform routine maintenance and major repair on your JET® tools. For the name of an Authorized Service Center in your area call 1-800-274-6848.

MORE INFORMATION

Walter Meier is consistently adding new products to the line. For complete, up-to-date product information, check with your local Walter Meier distributor, or visit waltermeier.com.

WARRANTY

JET products carry a limited warranty which varies in duration based upon the product (MW = Metalworking, WW = Woodworking).

90 DAY WARRANTY	1 YEAR WARRANTY	Body Repair Kits Bottle Jacks Cable Pullers Cold Saws Hoists-Air Hoists-Electric Metal forming Mill/Drills Milling Machines MW Bandsaws MW Drill Presses MW Finishing Equipment MW Lathes MW Precision Vises	2 YEAR WARRANTY	Palet Trucks Rigging Equip. Service Jacks Stackers Surface Grinders Tapping Trolleys-Air Trolleys-Electric Web Slings Winches-Electric	3 YEAR WARRANTY	WW Benchtop Tools	Beam Clamps Chain Hoist- Manual Lever Hoists Pullers-JCH Models Scissor Lift Tables Screw Jacks Trolleys-Geared Trolleys-Plain Winches-Manual WW Air Filtration WW Bandsaws WW Buffers	5 YEAR WARRANTY	WW Drill Presses WW Dust Collectors WW Dust Filters WW Dust Fittings WW Jointers WW Lathes WW Planers WW Sanders WW Shapers WW Tablesaws	LIFE LIFETIME WARRANTY	Fastening Tools Mechanics Hand Tools Striking Tools Vises (no -precision) Clamps
Warranty reverts to 1 Year Warranty if woodworking (WW) products listed above are used for industrial or educational purposes.											

WHAT IS COVERED?

This warranty covers any defects in workmanship or materials subject to the exceptions stated below. Cutting tools, abrasives and other consumables are excluded from warranty coverage.

WHO IS COVERED?

This warranty covers only the initial purchaser of the product.

WHAT IS THE PERIOD OF COVERAGE?

The general JET warranty lasts for the time period specified in the product literature of each product.

WHAT IS NOT COVERED?

Five Year Warranties do not cover woodworking (WW) products used for commercial, industrial or educational purposes. Woodworking products with Five Year Warranties that are used for commercial, industrial or education purposes revert to a One Year Warranty. This warranty does not cover defects due directly or indirectly to misuse, abuse, negligence or accidents, normal wear-and-tear, improper repair or alterations, or lack of maintenance.

HOW TO GET SERVICE

The product or part must be returned for examination, postage prepaid, to a location designated by us. For the name of the location nearest you, please call 1-800-274-6848.

You must provide proof of initial purchase date and an explanation of the complaint must accompany the merchandise. If our inspection discloses a defect, we will repair or replace the product, or refund the purchase price, at our option. We will return the repaired product or replacement at our expense unless it is determined by us that there is no defect, or that the defect resulted from causes not within the scope of our warranty in which case we will, at your direction, dispose of or return the product. In the event you choose to have the product returned, you will be responsible for the shipping and handling costs of the return.

HOW STATE LAW APPLIES

This warranty gives you specific legal rights; you may also have other rights which vary from state to state.

LIMITATIONS ON THIS WARRANTY

WALTER MEIER (MANUFACTURING) INC., LIMITS ALL IMPLIED WARRANTIES TO THE PERIOD OF THE LIMITED WARRANTY FOR EACH PRODUCT. EXCEPT AS STATED HEREIN, ANY IMPLIED WARRANTIES OR MERCHANTABILITY AND FITNESS ARE EXCLUDED. SOME STATES DO NOT ALLOW LIMITATIONS ON HOW LONG THE IMPLIED WARRANTY LASTS, SO THE ABOVE LIMITATION MAY NOT APPLY TO YOU.

WALTER MEIER SHALL IN NO EVENT BE LIABLE FOR DEATH, INJURIES TO PERSONS OR PROPERTY, OR FOR INCIDENTAL, CONTINGENT, SPECIAL, OR CONSEQUENTIAL DAMAGES ARISING FROM THE USE OF OUR PRODUCTS. SOME STATES DO NOT ALLOW THE EXCLUSION OR LIMITATION OF INCIDENTAL OR CONSEQUENTIAL DAMAGES, SO THE ABOVE LIMITATION OR EXCLUSION MAY NOT APPLY TO YOU.

Walter Meier sells through distributors only. The specifications in Walter Meier catalogs are given as general information and are not binding. Members of Walter Meier reserve the right to effect at any time, without prior notice, those alterations to parts, fittings, and accessory equipment which they may deem necessary for any reason whatsoever. JET®-branded products are not sold in Canada by Walter Meier.

Table of Contents

Warranty and Service.....	2
Table of Contents	3
Warnings.....	4
Introduction	6
Specifications	6
Machine Features.....	7
Unpacking and Assembly	8
Electrical Connection	8
Controls and Indicators	9
Blade Selection	10
Operations	10
Adjustments	14
Maintenance	18
Cleaning	20
Lubrication	20
Coolant	20
Troubleshooting.....	21
Parts.....	23
Saw Stand and Bed.....	23
Saw Stand and Bed – Parts Breakdown.....	25
Saw Head.....	26
Saw Head – Parts Breakdown.....	29
Electric Assembly – Parts and Breakdown	30
Wiring Diagram.....	31
Ordering Replacement Parts	32

The specifications in this manual are given as general information and are not binding. Walter Meier (Manufacturing) Inc., reserves the right to effect, at any time and without prior notice, changes or alterations to parts, fittings, and accessory equipment deemed necessary for any reason whatsoever.

Warnings

1. Read and understand the entire owner's manual before attempting assembly or operation.
2. Read and understand the warnings posted on the machine and in this manual. Failure to comply with all of these warnings may cause serious injury.
3. Replace the warning labels if they become obscured or removed.
4. The bandsaw is designed and intended for use by properly trained and experienced personnel only. If you are not familiar with the proper and safe operation of a bandsaw, do not use until proper training and knowledge have been obtained.
5. Do not use this bandsaw for other than its intended use. If used for other purposes, Walter Meier (Manufacturing) Inc., disclaims any real or implied warranty and holds itself harmless from any injury that may result from that use.
6. Always wear approved safety glasses/face shields while using this bandsaw. Everyday eyeglasses only have impact resistant lenses; they are not safety glasses.
7. Before operating the bandsaw, remove tie, rings, watches and other jewelry, and roll sleeves up past the elbows. Remove all loose clothing and confine long hair. Non-slip footwear or anti-skid floor strips are recommended. Do **not** wear gloves.
8. Wear ear protectors (plugs or muffs) during extended periods of operation.
9. Some dust created by power sanding, sawing, grinding, drilling and other construction activities contain chemicals known to cause cancer, birth defects or other reproductive harm. Some examples of these chemicals are:
 - Lead from lead based paint.
 - Crystalline silica from bricks, cement and other masonry products.
 - Arsenic and chromium from chemically treated lumber.
10. Your risk of exposure varies, depending on how often you do this type of work. To reduce your exposure to these chemicals, work in a well-ventilated area and work with approved safety equipment, such as face or dust masks that are specifically designed to filter out microscopic particles.
11. Do not operate this machine while tired or under the influence of drugs, alcohol or any medication.
12. Make certain the switch is in the **OFF** position before connecting the machine to the power supply.
13. Make certain the machine is properly grounded.
14. Make all machine adjustments or maintenance with the machine unplugged from the power source.
15. Remove adjusting keys and wrenches. Form a habit of checking to see that keys and adjusting wrenches are removed from the machine before turning it on.
16. Keep safety guards in place at all times when the machine is in use. If removed for maintenance purposes, use extreme caution and replace the guards immediately.
17. Make sure the bandsaw is firmly placed on a secure foundation.
18. Check damaged parts. Before further use of the machine, a guard or other part that is damaged should be carefully checked to determine that it will operate properly and perform its intended function. Check for alignment of moving parts, binding of moving parts, breakage of parts, mounting and any other conditions that may affect its operation. A guard or other part that is damaged should be properly repaired or replaced.
19. Provide for adequate space surrounding work area and non-glare, overhead lighting.
20. Keep the floor around the machine clean and free of scrap material, oil and grease.



Warnings

21. Keep visitors a safe distance from the work area. **Keep children away.**
22. Make your workshop child proof with padlocks, master switches or by removing starter keys.
23. Give your work undivided attention. Looking around, carrying on a conversation and “horse-play” are careless acts that can result in serious injury.
24. Maintain a balanced stance at all times so that you do not fall into the blade or other moving parts. Do not overreach or use excessive force to perform any machine operation.
25. Use the right tool at the correct speed and feed rate. Do not force a tool or attachment to do a job for which it was not designed. The right tool will do the job better and safer.
26. Use recommended accessories; improper accessories may be hazardous.
27. Maintain tools with care. Keep saw blades sharp and clean for the best and safest performance. Follow instructions for lubricating and changing accessories.
28. Turn off the machine before cleaning. Use a brush or compressed air to remove chips or debris — do not use your hands.
29. Do not stand on the machine. Serious injury could occur if the machine tips over.
30. Never leave the machine running unattended. Turn the power off and do not leave the machine until it comes to a complete stop.
31. Remove loose items and unnecessary work pieces from the area before starting the machine.
32. Always wear leather gloves when handling saw blade. The operator shall not wear gloves when operating the machine.
33. All doors shall be closed, all panels replaced, and other safety guards in place prior to the machine being started or operated.
34. Be sure that the blade is not in contact with the workpiece when the motor is started. The motor shall be started and you should allow the saw to come up to full speed before bringing the saw blade into contact with the workpiece.
35. Keep hands away from the blade area.
36. Remove any cut off piece carefully while keeping your hands free of the blade area.
37. Saw must be stopped and electrical supply must be cut off before any blade replacement or adjustment of blade support mechanism is done, or before any attempt is made to change the drive belts or before any periodic service or maintenance is performed on the saw.
38. Remove loose items and unnecessary workpieces from area before starting machine.
39. Bring adjustable saw guides and guards as close as possible to the workpiece.
40. Always wear protective eye wear when operating, servicing, or adjusting machinery. Eyewear shall be impact resistant, protective safety glasses with side shields complying with ANSI Z87.1 specifications. Use of eye wear which does not comply with ANSI Z87.1 specifications could result in severe injury from breakage of eye protection.
41. Nonslip footwear and safety shoes are recommended.
42. The workpiece, or part being sawed, must be securely clamped before the saw blade enters the workpiece.
43. Saw must be stopped and electrical supply cut off or machine unplugged before reaching into cutting area.
44. Avoid contact with coolant, especially guarding your eyes.

Familiarize yourself with the following safety notices used in this manual:

CAUTION This means that if precautions are not heeded, it may result in minor injury and/or possible machine damage.

WARNING This means that if precautions are not heeded, it may result in serious injury or possibly even death.

Introduction

The JET Model J-7015 Horizontal Cut-off Bandsaw is designed for high production cut-off work. Four cutting speeds and a hydraulic feed control allow the efficient cutting of virtually any material.

The Model J-7015 Horizontal Cut-off Bandsaw is equipped with a coolant system that can greatly extend blade life and speed the cutting of a variety of materials that are best cut with cutting fluids and coolants.

Specifications

Model Number	J-7015
Stock Number	414450
Capacity:	
Rectangular Stock at 90° (in.)	9 x 13
Rectangular Stock at 45° (in.)	9 x 8
Round Stock at 90° (in.).....	9
Round Stock at 45° (in.).....	9
Flat Stock (in.)	8 x 10
Speeds (FPM)	82, 132, 170, 235
Motor	TEFC, 1-1/2 Horsepower, Capacitor Start, 1725 RPM, 1 Phase, 115/230V
Blade Size (in.)	1 x 0.035 x 114.5
Blade Guides.....	Tungsten carbide tip & ball bearing, eccentric shaft
Material	Tungsten carbide inserts
Sides.....	Eccentric shaft, ball bearings
Blade Wheel (in.)	11-5/8 diameter, cast iron
Dimensions (LxWxH)(in.).....	62.5 x 22.4 x 48.4 (cutoff position)
Net Weight, approx. (lbs.).....	551
Vise	Rapid acting, screw tightening vise
Coolant Pump	1/8 Horsepower, 1Phase, 115/230V

Machine Features

Figures 1 and 2 depict the main features of the Model J-7015 Horizontal Cut-Off Bandsaw. The machine consists of a machine base onto which is installed a saw head.

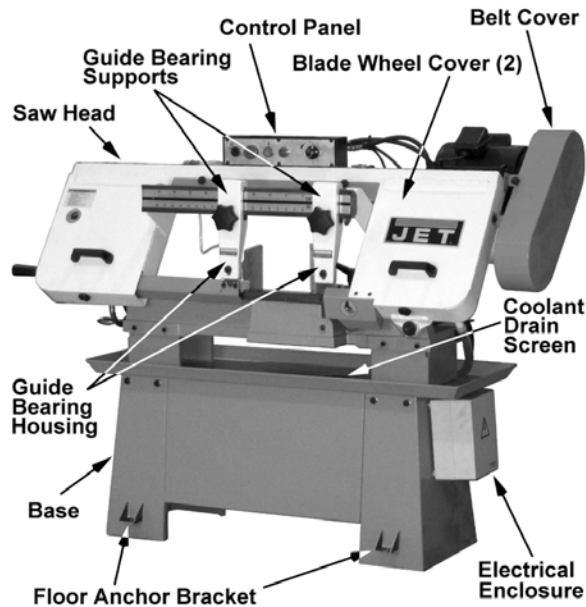

Figure 1

Machine Base

The machine base consists of a coolant collection pan mounted on two panels that form the legs of the machine. A shelf is provided under the collection pan that supports a coolant tank.

The machine bed mounts on the top of the collection pan. The bed supports the vise and the vise-tightening lead screw.

The coolant tank is equipped with a pump/motor assembly. The pump/motor circulates coolant through tubing to cool and lubricate the saw blade, the blade guides, and the workpiece.

A drainpipe is provided to connect the collection pan to the coolant tank. A screen is provided in the collection pan to screen-out cutting debris as the coolant drains into the coolant tank. Coolant is added to the tank by pouring coolant into the collection pan. The tank is easily removed from its shelf for cleaning and maintenance.

Saw Head

The saw head (Figure 2) consists of a drive motor, drive pulleys, gearbox, blade wheels, blade guides and supports, control panel, blade tension/blade tracking mechanism, wire brush, and the saw blade.

The drive motor is mounted on a pivoting plate that swings outward to provide V-belt tension. The motor is fitted with a step pulley; the V-belt connects to a second step pulley that is mounted on the input shaft of the gearbox.

A speed-reducing gearbox is mounted on the back side of the blade wheel box on the right side of the machine. The blade wheel (drive wheel) is installed on the output shaft of the gearbox.

A second blade wheel is located in a blade wheel box on the left of the machine. The blade wheel (driven wheel) is mounted on a shaft that is part of the blade tension/tracking mechanism. The blade tension mechanism is used to tighten the saw blade on the blade wheels.

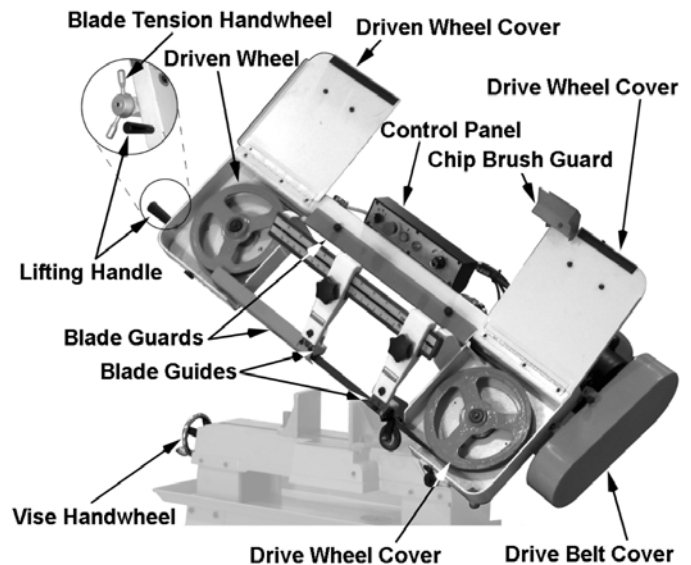

Figure 2

The mechanism also has adjustment screws that enable the saw blade to “track” evenly on the blade wheels. The adjustment screws change the angle of the driven blade wheel shaft so the wheels are aligned. Tracking adjustments are generally made after the saw blade is changed but may be required periodically due to wear over time.

An electrical enclosure is attached to the leg panel on the right side of the machine. The enclosure contains the switches and fuses required for operation and protection of the drive motor (Figure 3).

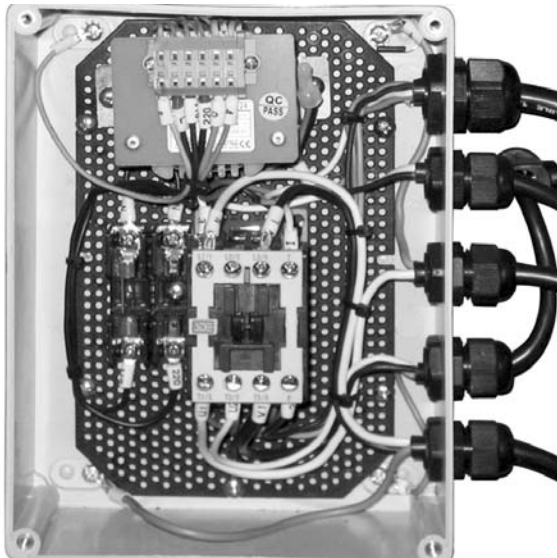

Figure 3

Work Stop

A work stop is provided with the machine to allow cutting multiple pieces of identical length (refer to Figure 12). The stop consists of a rod onto which is installed a stop bracket, a tapered stop, a clamping knob and a locking handle. The rod is installed in a bore in the front of the saw bed. The stop bracket is positioned on the rod with the tapered stop toward the end of the workpiece. The bracket is moved in or out on the rod to establish the length of the workpiece.

Control Panel

The control panel is mounted on the top of the saw head. Refer to the *Controls and Indicators* section (page 9) for a description of the controls.

Unpacking and Assembly

Machine Setup

The cut-off saw has been pre-adjusted at the factory and several test pieces have been cut to verify cutting accuracy.

Remove the saw from the shipping skid; discard any hold-down devices. Place the saw on the shop floor; secure the saw to the floor using mounting anchors secured through four holes in the machine base. If the saw will be used to cut long pieces of stock, allow plenty of room for the length of the stock.

Minimal assembly is required (see to Fig. 4), consisting of mounting the *control box*, *motor*, *pulley guard/cover assembly* and *motor drive belt*. The mounting hardware is already in place on the saw head. Loosen or remove the hardware, placing the components (listed above) in place and secure. For the *drive belt*, refer to the *Drive Belt* section on page 19.

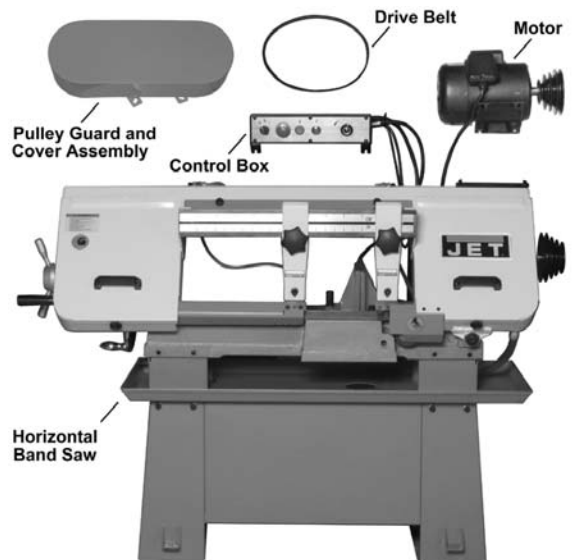

Figure 4

Electrical Connection

⚠ WARNING Electrical connection must be made by a licensed electrician. The wiring methods and practices must comply with local electrical codes.

⚠ WARNING The machine uses high voltage electrical power that poses a significant risk of serious injury or death if proper precautions are not observed

Connect the machine to the electrical power branch circuit (refer to the *Wiring* section on page 31). Observe the following guidelines when connecting the saw to the power source.

1. Make sure the saw is disconnected from the electrical power branch circuit (trip the required circuit breakers or remove the required fuses).

- Place a warning placard or tag on the service panel to prevent accidental electrical shock.
 - When installing the motor power cord into a receptacle, make sure the plug is compatible with the receptacle.
 - When using hard-wired connections, connect the wires as shown in the **Wiring Data** section.
 - Install the fuses or reset the breakers.
- Check operation of the saw.

- Loosen the drive motor locking handle. Pivot the motor inward to slacken the belt.
- Select the speed using the placard on the cover. Put the V-belt in the pulley grooves of the pulley for the desired speed. Refer to *Figure 6* for belt locations and the speeds available.

Controls and Indicators

Control Panel

The operating controls for the cut-off saw are located on the control panel (Figure 5) and consist of the following controls and indicators:

Coolant Pump Switch – turns the coolant pump on and off.

Emergency Stop Switch – press to stop the drive motor. **Note:** A micro switch also stops the motor when the workpiece is cut and the saw head is completely down.

Start Switch – press to start the drive motor. The saw head must be in the raised position.

Power Light – indicates that machine is plugged in and the outlet circuit breaker is turned on. The machine does not need to be running for the power light to be on.

Feed Rate Control – this knob is used to set the amount of downward force that is applied to the saw blade. The feed rate is proportional to the opening of the valve. When set to zero, the saw head is locked in the raised position. Increasing the valve opening (counterclockwise adjustment) increases the feed rate; decreasing the valve opening (clockwise adjustment) reduces the feed rate.

Blade Speeds

The Model J-7015 horizontal cut-off bandsaw has four blade speeds. The different speeds are obtained by changing the position of the motor drive V-belt on step pulleys. Change blade speeds as follows:

- Disconnect the electrical power from the cut-off saw branch circuit to prevent accidental motor start-up
- Set the saw head at the fully down position.
- Remove the knob from the drive belt cover. Swing cover out and downward to expose the V-belt and pulleys.

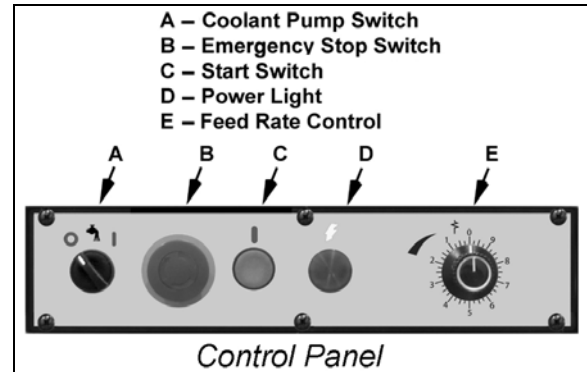

Figure 5

Material to Be Cut	Belt Speed				Belt Position
	60Hz		50Hz		
	fpm	mpm	fpm	mpm	
Tool Steel, Stainless Steel, Alloy Steel, Phosphor Bronze, Hard Bronze, Hard Cast Iron, Malleable Iron	82	25	68	21	A
Mild Steel, Soft Cast Iron, Medium Hard Brass, Medium Hard Bronze	132	40	110	33	B
Soft Brasses and Bronzes, Hard Aluminum, Plastics	170	51	142	43	C
Plastics, Soft and Medium Aluminum, Wood, Other Light Materials	235	71	196	60	D

Note: Belt position A shown below

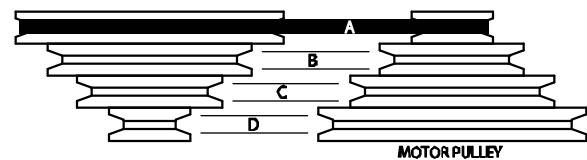

Figure 6

- Pivot the motor outward to tighten the V-belt. Tighten the locking handle.
- Check V-belt tension by pushing the V-belt firmly downward; press down about midway between the pulleys. When properly tightened, the V-belt should depress no more than the width of the belt.

Blade Selection

The cut-off saw is delivered with a saw blade that is adequate for a variety of cut-off jobs on a variety of common materials. A 10-tooth, general-purpose blade is provided as standard equipment with the machine.

Refer to Figure 6 for the speeds recommended for various materials. These speeds, while appropriate for many common shop cutting needs, do not encompass the wide variety of special blade configurations (tooth pitch and set) and special alloys for cutting unusual or exotic materials.

A coarse blade could be used for a solid steel bar, but a finer tooth blade would be used on a thin-wall steel tube. In general, the blade choice is determined by the thickness of the material; the thinner the materials; the finer the tooth pitch.

A minimum of three teeth should be on the workpiece at all times for proper cutting. The blade and workpiece can be damaged if the teeth are so far apart that they straddle the workpiece.

For very high production on cutting of special materials, or to cut hard-to-cut materials such as stainless steel, tool steel, or titanium, you can ask your industrial distributor for more specific blade recommendations. The supplier that provides the workpiece material should be able to provide you with very specific instructions regarding the best blade (and coolant or cutting fluid, if needed) for the material or shape supplied.

Blade Break-in Procedures

New blades are very sharp and, therefore, have a tooth geometry that is easily damaged if a careful break-in procedure is not followed. Consult the blade manufacturer's literature for break-in of specific blades on specific materials. However, the following procedure will be adequate for break-in of JET-supplied blades on lower alloy ferrous materials.

1. Clamp a section of round stock in the vise. The stock should be 2 inches or larger in diameter.
2. Operate the saw at low speed. Start the cut with a very light feed rate.
3. When the saw has completed 1/3 of the cut, increase the feed rate slightly and allow the saw to complete the cut.

4. Keep the hydraulic cylinder needle valve in the same position and begin a second cut on the same or similar workpiece.
5. When the blade has completed about 1/3 of the cut, increase the feed rate.

Watch the chip formation until cutting is at its most efficient rate and allow the saw to complete the cut (refer to *Evaluating Blade Efficiency* on page 10). The blade is now considered ready for use.

Operations

Hydraulic Feed Control

The weight of the saw head provides the force needed to cut through the workpiece. The cut-off saw has a hydraulic cylinder that controls the feed rate of the saw.

The hydraulic feed control circuit consists of a single acting *hydraulic cylinder* (Figure 7) and a *feed rate control* (Figure 5). The feed control cylinder resists motion in the downward direction to control the feed rate. The control cylinder offers no resistance when raised upward.

The *feed rate control knob* (Figure 5) controls the rate at which the saw head is lowered. The control knob (needle valve) controls the rate at which the hydraulic fluid is released from the hydraulic cylinder. When the needle valve is closed, the cylinder is locked. With the needle valve slightly open, the cylinder permits slow, or light, downward force. Opening the needle valve further increases the feed rate and applies more weight to the saw blade and workpiece.

The needle valve is adjusted until the saw is operating efficiently. The efficiency of operation is usually evaluated by observing chip formation. Blade efficiency is further described below.

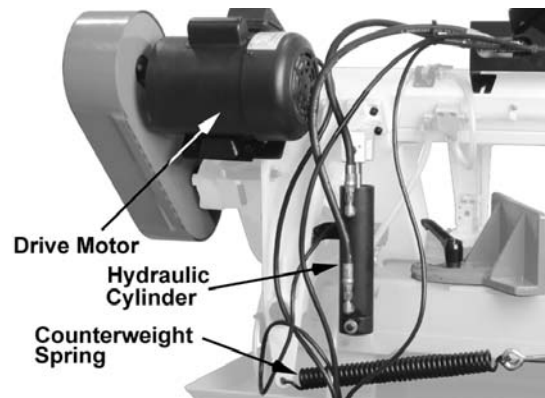

Figure 7

Evaluating Cutting Efficiency

Is the blade cutting efficiently? The best way to determine this is to observe the chips formed by the cutting blade.

If the chip formation is powdery, then the feed is much too light, or the blade is dull.

If the chips formed are curled, but colored – blue or straw colored from heat generated during the cut – then the feed rate is too high.

If the chips are slightly curled and are not colored by heat – the blade is sufficiently sharp and is cutting at its most efficient rate.

Work Setup

Referring to Figure 8:

1. Set the *feed rate control knob* (C) to zero.
2. With the *lifting handle* (A) raise the saw head (B).
3. Turn the *visé handwheel* (D) counterclockwise enough to free the *moveable visé jaw* (E). Then pull the moveable visé jaw away from the *fixed visé jaw* (H).
4. Place the *workpiece* (F) on the work table (G).

For long workpieces, provide support at the other end. If necessary, provide additional downward clamping to hold the workpiece securely on the worktable.

5. Clamp the *workpiece* (F) in the visé by first pushing the *moveable visé jaw* (E) against the workpiece. Then rotate the *visé handwheel* (D) clockwise to secure the workpiece.

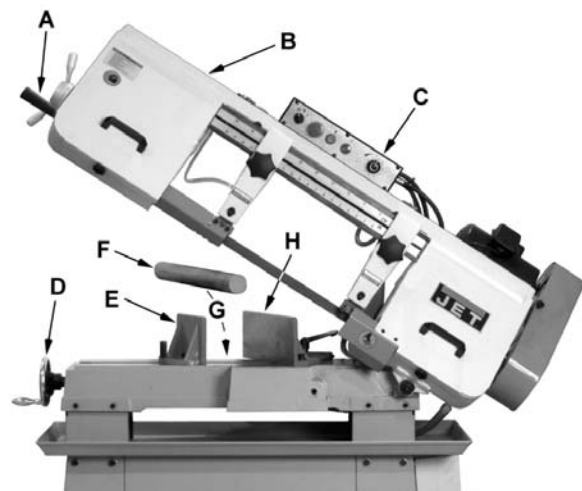

Figure 8

Setting The Visé For Angle Cuts

Referring to Figure 9, the visé can be adjusted through a 45-degree arc as follows:

1. Loosen the *lock handle* (E) that secures the *fixed visé jaw* (D).
2. Rotate the *fixed visé jaw* (D) to the desired angle, setting it to the *scale* on the back edge of the table.
- For accurate cuts, use a variable protractor to set the position of the jaw, aligning one side of the protractor with the blade.
3. Tighten the *lock handle* (E).
4. Loosen the *hex head bolt* (A) on the *moveable visé jaw* (C).
5. Place the *workpiece* (B) between the *visé jaws* (C, D).
6. Set the *moveable visé jaw* (C), pressing it against the side of the *workpiece* (B) and *fixed visé jaw* (D).
7. Tighten the *hex head bolt* (A) on the moveable visé jaw to secure the jaw.

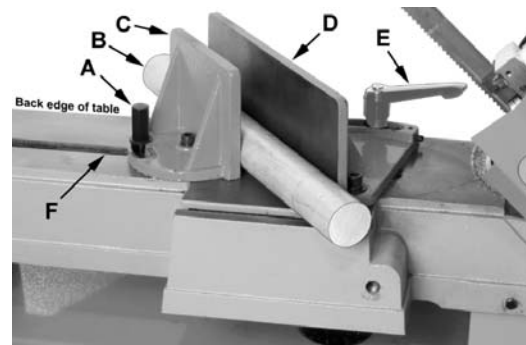

Figure 9

Setting the Visé for Square Cuts

The procedure for setting the visé for square cuts is identical to setting for angle cuts (above) except that a *machinist's square* is used to set the angle of the *fixed visé jaw* (J, Fig. 10). Align one side of the square with the side of the *slot* (G, Fig. 10) in the table.

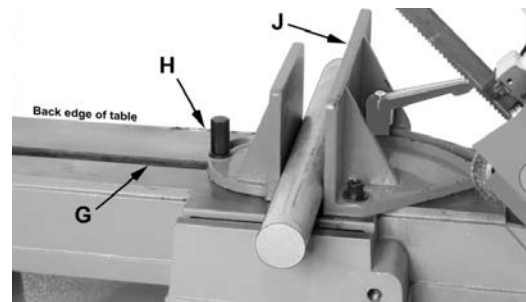

Figure 10

Starting the Saw

Important: The efficient operation of the cut-off saw is dependent upon the condition of the saw blade. If the performance of the saw begins to deteriorate, the first item that you should check is the blade.

If a new blade does not restore the machine's cutting accuracy and quality, refer to the troubleshooting guide (or the blade manufacturer's guide) for conditions to consider and adjustments that can be made to increase the life of the blade.

To change the blade, refer to the *Changing Blades* section on page 18.

⚠ WARNING Never operate the saw without blade covers in place.

⚠ CAUTION Make sure the blade is not in contact with the workpiece when the motor is started. Do not drop the saw head on the workpiece or force the saw through the workpiece.

To start the saw:

1. Clamp the workpiece in the vise. Refer to Figure 11 for examples of workpieces in the vise.

Be sure the blade is not in contact with the workpiece when the motor is started.

2. Start the motor and allow the saw to come up to speed.
3. Slowly set the saw down onto the workpiece and adjust cutting speed with the feed control knob (described on page 9).
4. **Do not drop the saw head or force the cut.** Let the weight of the saw head provide the cutting force.
5. The saw will automatically shut off at the end of the cut.

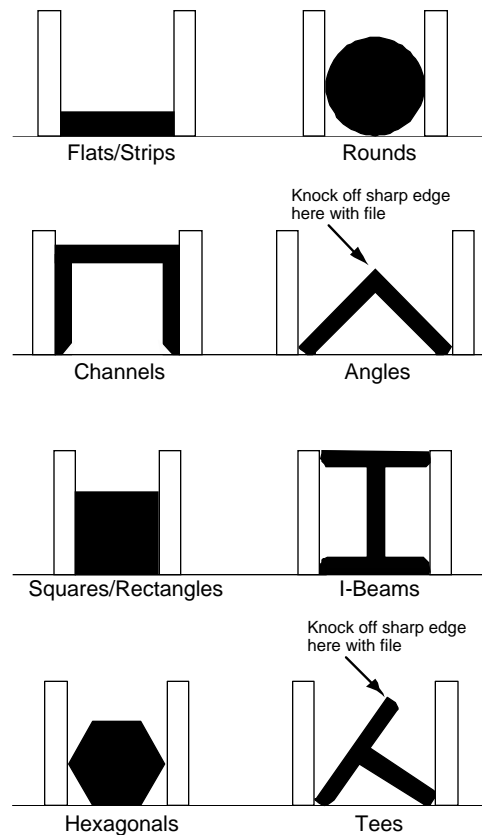

Figure 11

Coolant Flow and Nozzle Position

CAUTION The coolant pump must be submerged before operating to prevent damage to the pump.

Adjust the coolant flow shut-off valve at the top of the saw head weldment. The flow should be no more than the saw blade can draw into the workpiece by the movement of the blade.

The coolant flow can be stopped in two ways:

- ❑ by the *coolant selector switch* (A, Fig. 4) on the control box (the preferred method)
- ❑ by closing the shut-off valve

Note: The coolant pump is self-circulating when the shut-off valve is closed.

Setting the Work Stop

Referring to Figure 12:

The *work stop* is an accessory that is included with the JET J-7015 Bandsaw. It is used to set up the saw for making multiple cuts of the same length.

CAUTION Do not allow the blade to rest on the workpiece when the saw is not cutting.

Thread the *stop rod* (A) into the threaded opening on the front of the saw bed (B) as shown.

Set the work stop as follows:

1. Loosen the *stop arm* (C).
2. Position the *stop arm* (C) on the *stop rod* (A) to obtain the desired length of cut on the *workpiece* (D).
3. Rotate the *stop arm* (C) so it contacts the end of the *workpiece* (D).
4. Secure the *stop arm*.

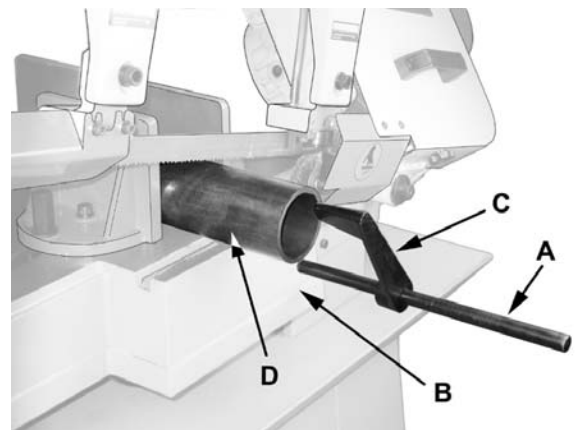

Figure 12

Adjustments

Blade Tracking Adjustment

Refer to Figures 13 and 14.

Blade tracking has been set and tested at the factory. *Adjustment is rarely required* when the blade is used properly or if the blade is correctly welded.

If adjustment is needed:

1. Using the *blade tension handwheel* (D), make sure the blade is properly tensioned.

Note: Blade tensioning is described in the *Changing Blades* section on page 18).

Keep proper tension at all times.

2. Raise the *saw head* (A) as shown.
3. Open the *wheel guards* (B).
4. Remove both of the *blade-guide bearing bracket assemblies* (C).
5. Loosen three *hex locking screws* (E) in the *head weldment* (G).

CAUTION While performing the following, keep the blade from rubbing excessively on the shoulder of the wheel. Excessive rubbing will damage the wheel and/or the blade.

6. Start the saw. Turn the *adjustment screws* (F) to tilt the *idler wheel* (Figure 14) until the blade is touching the shoulder of the idler wheel.

Note: As a general rule, make the *same adjustment* to the two *adjustment screws* on the right (F). The single adjustment on the left is independent.

7. Next, turn the *adjustment screws* (F) so the blade starts to move away from the shoulder of the wheel – then immediately turn the adjustment screws in the other direction so the blade stops – then moves slowly toward the shoulder.

WARNING Keep fingers clear of the blade and wheel to avoid injury.

8. Turn the *adjustment screws* (F) to stop the motion of the blade on the wheel as it gets closer to the wheel shoulder.

Put a 6-inch length of *paper* (J, Fig. 14) between the blade and the wheel as shown (the saw is still turned on). The paper should not be cut as it passes between the wheel shoulder and the blade.

9. Turn the *adjustment screws* (F) slightly.

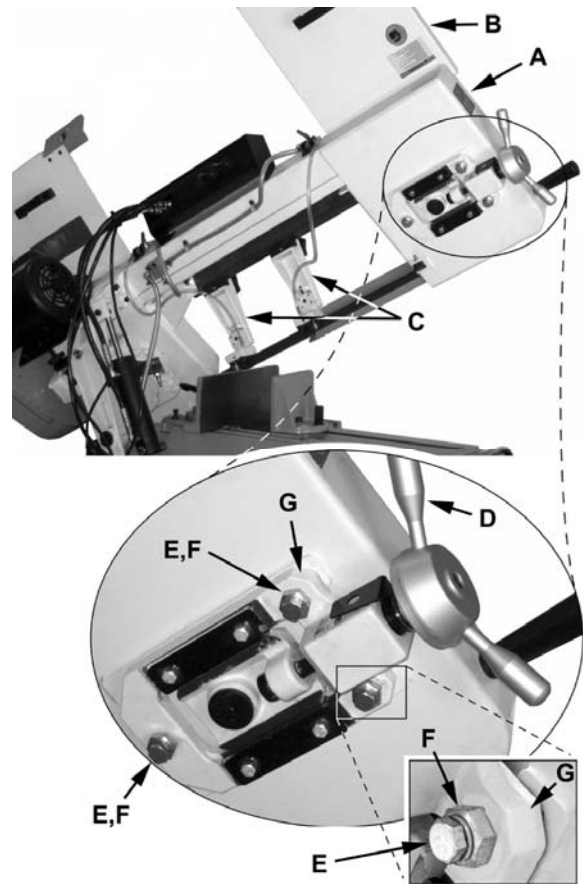

Figure 13

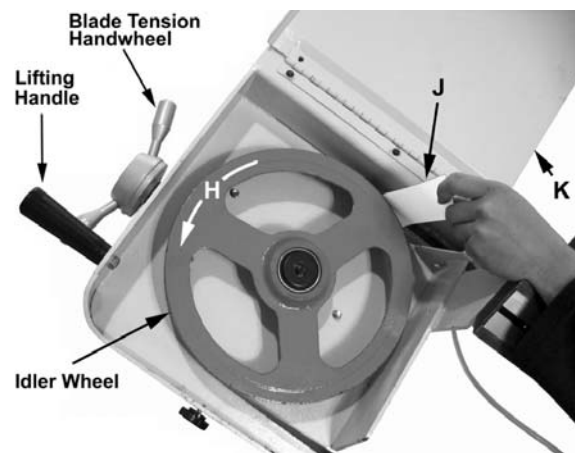

Figure 14

Repeat the insertion of the paper between the wheel shoulder and the blade until the paper is cut in two pieces.

Note: You may have to repeat the check with the paper several times before the blade and the shoulder cut the paper into two pieces. Do not hurry the adjustment. Patience and accuracy here will pay off with better, more accurate, quieter cutting and much longer machine and blade life.

When the paper is cut:

10. Turn the *adjustment screws* (F) slightly in the counter-clockwise direction. This assures that the blade is not touching the shoulder of the wheel.
11. Shut off the saw.
12. Tighten the *hex locking screws* (E).
13. Install the *blade-guide bearing bracket assemblies* (C, Fig. 13).
14. Position the guides so the top bearing just touches the blade (see *Blade Guide Bearing Adjustment* on page 16).
15. Close the *wheel covers* (K, Fig. 14).

Blade Guide Adjustment

Referring to Figure 15:

The J-7015 Bandsaw has two adjustable blade guide assemblies, each consisting of the *blade guide support* or bracket (B, H) and *blade guide* (A).

The position of the blade guides is important in order to make accurate cuts and prolong blade life and is determined by the size of the workpiece. Adjustment is made as follows:

Left Blade Guide

1. Place the *workpiece* (G) in the *vise* (F) and clamp tightly (refer to *Work Setup* on page 8).
2. Loosen the left *lock knob* (C) only.
3. Slide the *guide support* (D) left or right so that it just clears the piece to be cut (G).
4. Tighten the *lock knob* (C).

Right Blade Guide

The *right blade guide* assembly is set at the factory and rests against the *stop* (E). It normally does not require adjustment, except to provide clearance for workpieces to be cut at a great angle. If adjustment is required, the procedure is the same as for the left blade guide adjustment.

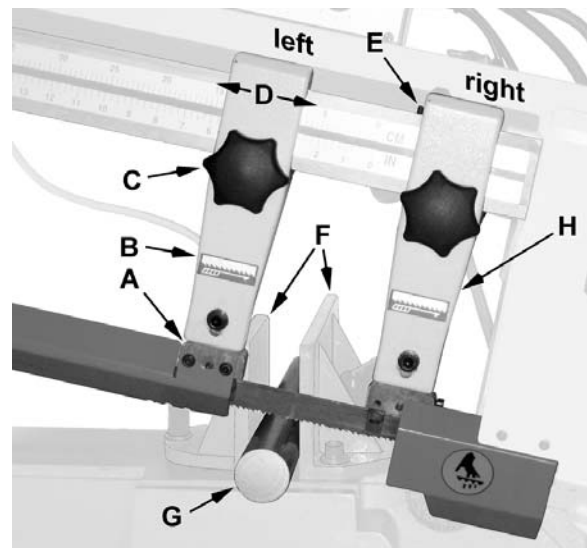

Figure 15

Blade Guide Bearing Adjustment

Referring to Figure 16:

Guide bearings and *guide inserts* are located on either side of the saw blade and provide stability for the blade when the saw is in operation. These bearings rotate on an eccentric shaft so the distance from the blade can be adjusted for optimal performance.

Blade guides provide blade support.

Guide bearings and blade guides are initially adjusted at the factory and should rarely require adjustment.

It is always better to try a new blade when cutting performance is poor. If performance remains poor after changing the blade, check the blade guides for proper spacing. For most efficient operation and maximum accuracy, clearance between the blade and the guide bearings should be 0.001-inch. The bearings will still turn freely with this clearance. If the clearance is incorrect, the blade may track off the drive wheel.

⚠WARNING Disconnect the cut-off saw from its electrical power source.

⚠CAUTION Check the blade to make sure the welded section is the same thickness as the rest of the blade. If the blade is thicker at the weld, the guide bearings may be damaged.

If required, adjust first one *guide bearing and blade guide assembly* then the other as follows:

1. Using a 3mm hex wrench, loosen two *set screws* (A) securing the eccentric bushings.
2. Using a 5mm hex wrench, loosen two *socket head cap screws* (D) securing the *carbide blade guides* (E).
3. Position the *bearings* (B) by turning the *bushings* (C) with a flat-head screwdriver. Set the clearance between the *bearings* (B) and *blade* (F) at approximately 0.001 inch.

When properly adjusted, the blade should be in a vertical position between the bearings as shown in Figure 17.

4. Tighten the *set screws* (A).
5. Adjust the *blade guides* (E) so they support the blade without pinching and tighten the socket head cap screws.
6. When the adjustment is correct, the guide bearings should rotate freely with slight pressure of the finger (blade stopped).

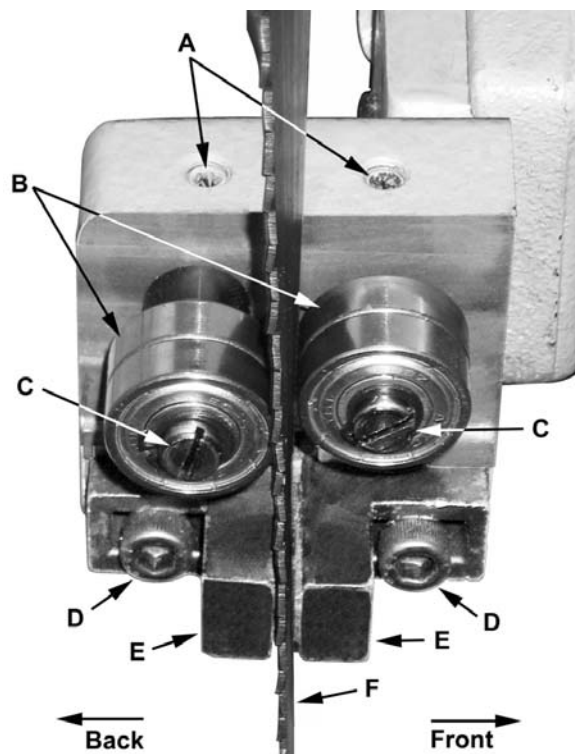

Figure 16

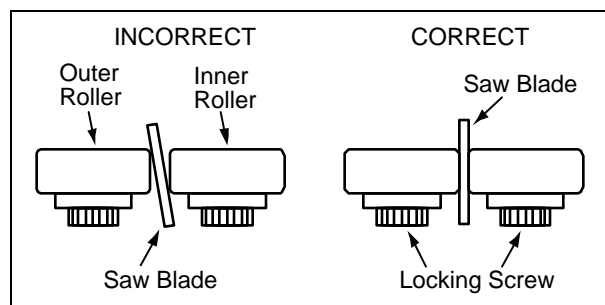

Figure 17

Drive Belt Tension Adjustment

The *V-belt* will stretch with use and may occasionally require tension adjustment. To adjust see the Changing Drive Belt section (page 19) steps 1, 2, 6, and 7.

Verifying Adjustment Accuracy

Refer also to Figure 18.

Test cuts can be used to determine whether or not you have adjusted the blade accurately. Use 2 inch round bar stock to perform these test cuts, as follows:

1. With the bar stock securely clamped in the vise, make a cut through the bar stock.
2. Mark the top of the bar stock.
3. Move the bar stock about 1/4 inch past the blade so you can begin a second cut.
4. Rotate the bar stock 180 degrees so the mark you made is now at the bottom of the cut.
5. Make a cut through the bar stock.
6. Use a micrometer to measure the thickness variation between the top and bottom of the disk you have cut from the bar stock.

The saw blade can be considered correctly adjusted when the variation measured is no more than 0.012 inch across the face of the disk. If you do not have a piece of 2-inch bar stock available for a test cut, use a larger diameter test workpiece rather than a smaller one. The maximum thickness variation on any test piece should be no more than 0.003 inch, per side, per inch of stock diameter.

Switch Adjustment

⚠WARNING Disconnect the cut-off saw from its electrical power source.

Referring to Figure 19:

Loosen the *jam nut* and set the *adjustment screw* so that the *limit switch* will actuate to the off position when the saw has cut through the workpiece.

Counterbalance Spring Tension

⚠WARNING Disconnect the cut-off saw from its electrical power source.

The *counterbalance spring* is located on the rear of the saw table (refer to Figure 20). The counterbalance spring is used to adjust the amount of down force the saw arm puts on the workpiece when the hydraulic control cylinder is fully open.

If adjustment is needed:

1. Raise the saw arm to its full upright position and lock it in position.
2. Set the spring tension by adjusting the nut until 1-1/4 to 1-1/2 inches of are exposed on the right side of the eyebolt mount.

The saw can now be returned to service.

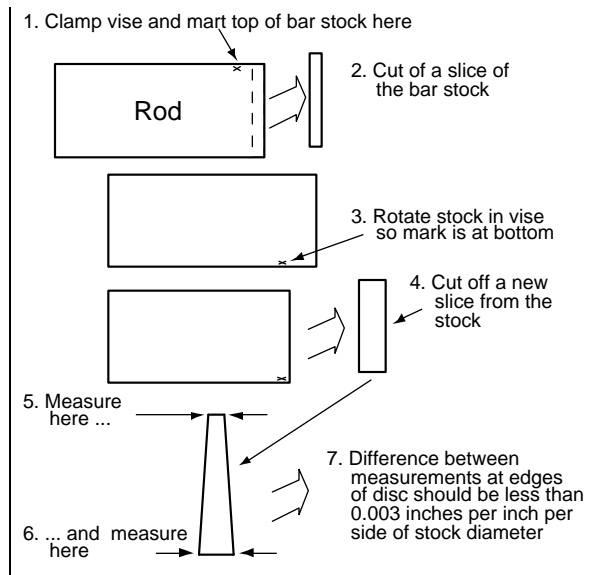

Figure 18

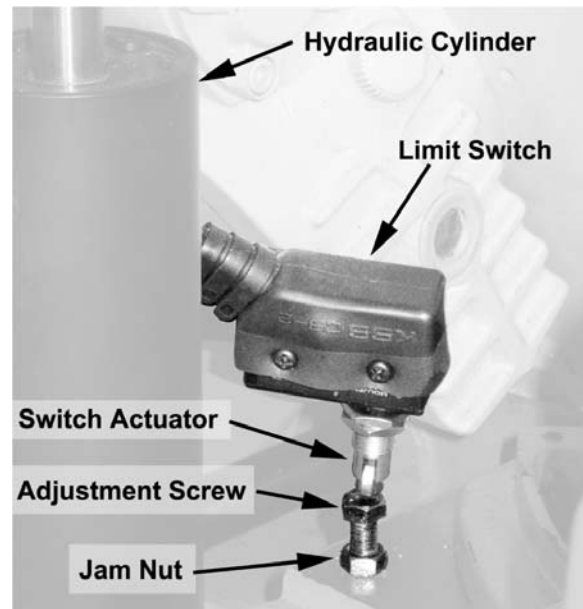

Figure 19

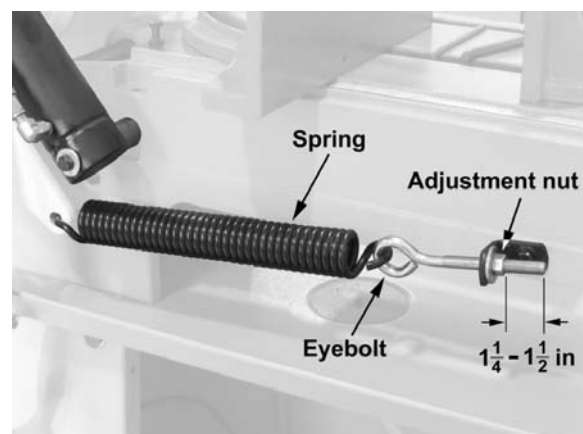

Figure 20

Maintenance

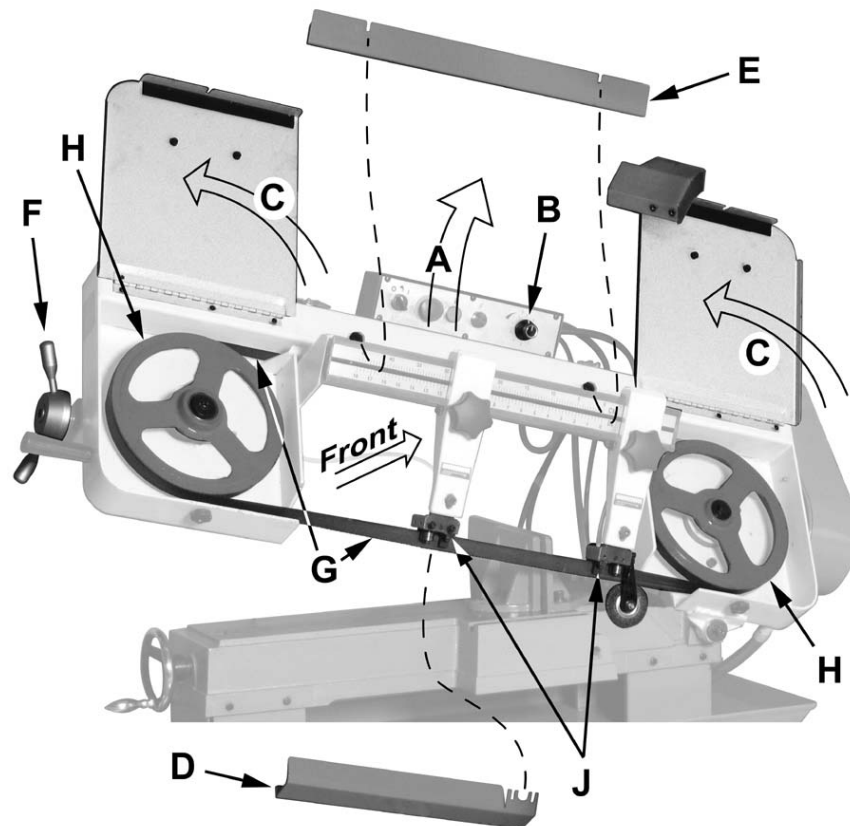

Figure 21

Changing Blades

▲WARNING Use leather gloves when changing the saw blade to protect your hands from cuts and scratches. Use protective eye wear that meets ANSI Specification Z87.1

▲WARNING Disconnect the cut-off saw from its electrical power source.

Referring to Figure 21:

1. Raise the *saw head* (A). Set the *feed rate control knob* (B) to zero to lock the hydraulic cylinder, which will hold the saw head in place.
2. Open two hinged *blade wheel covers* (C).
3. Remove the *blade guard* (D) and *column blade cover* (E).
4. Turn the *blade tension handle* (F) counter-clockwise until the *blade* (G) hangs loose.
5. Using leather gloves to prevent cuts and scratches, pull the *blade* (G) off the *drive wheels* (H) and out of the *blade guides* (J).

Store the removed blade carefully before proceeding.

6. Slide the new blade into the *blade guides* (J), then loop the *blade* (G) around the *drive wheels* (H) such that the teeth face towards the back and the smooth side faces towards the front.

This will permit the vertical side of the teeth to contact the workpiece first.

7. Push the *blade* (G) so it is seated against the shoulders of the *wheels* (H).

When it is seated against the shoulder, turn the *blade tension handle* (F) clockwise to increase the tension. Do not over-tension the blade; tighten it just enough so it does not slip while cutting.

8. When the blade is properly tensioned, reconnect the saw to the electrical power source.
9. Check and adjust the tracking of the blade. Refer to *Blade Tracking Adjustment* (on page 14) if necessary.
10. Close the *wheel covers* (C).
11. Put 2 to 3 drops of oil on the blade.

Changing the Drive Belt

Referring to Figures 22 and 23:

⚠WARNING Disconnect the cut-off saw from its electrical power source.

1. Set the arm at the full horizontal position.
2. Open the drive *belt cover* to expose the *V-belt* and *pulleys*.
3. Loosen the *belt tension adjust knob* located in the rear under the motor (see Figure 23 for knob direction). Lift the *motor* upward to loosen the belt.
4. Remove the worn *V-belt*.
5. Put the replacement *V-belt* in the pulley position for the speed you require (refer to the *Blade Speeds* section on page 9).
6. Tighten the *V-belt* by turning the *belt tension adjust knob* (see Figure 23). The belt must be secure enough so it does not slip when the machine is running. Do not over tighten. This will cause premature wear on belt and pulley bearings.
7. Reinstall drive *belt cover* and install knob.

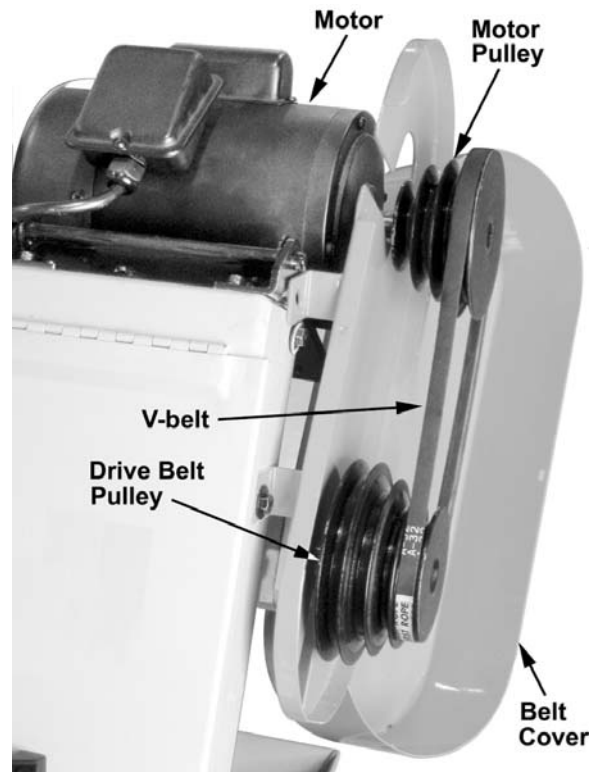

Figure 22

Replacing the Drive Motor

⚠WARNING Disconnect the cut-off saw from its electrical power source.

Referring to Figure 24:

1. Remove the drive *V-belt* (see *Changing the Drive Motor Belt* above).
2. Open the motor junction box and disconnect the power cord wires from their terminals.
3. Remove four *screws and washers* (A) that secure the *motor* (B) to the *mounting plate* (C).
4. Installation of a new motor is a reversal of the above steps. Also, complete steps 6 through 8 in *Changing Blade Speed* (page 9) to complete tensioning of the *V-belt* to the correct tension — use a straight edge to be certain the motor pulley is correctly aligned with the speed reducer pulley.

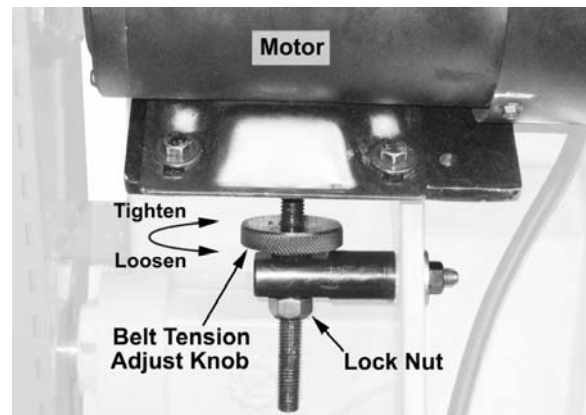

Figure 23

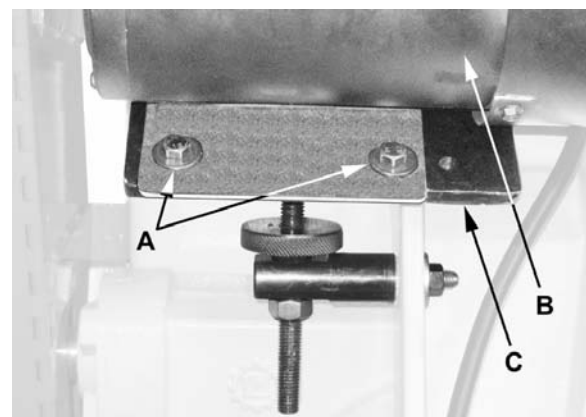

Figure 24

Cleaning

1. Clean off any preservative on machine surfaces.

After cleaning:

2. Coat machined surfaces of the cutoff saw with a medium consistency machine oil. Reapply the oil coating at least every six months.
3. Clean up accumulated saw cuttings after use. Make sure the lead screw and rapid nut are kept free from saw cuttings and other material that would cause damage.
4. Clean the chip sludge from the coolant tank. The frequency should be determined by how often the saw is used.

Lubrication

Lubricate the following components at the specified frequencies and using the lubricants defined as follows:

Ball Bearings – the bearings are lubricated and sealed – periodic lubrication is not required.

Blade Guide Bearing – the bearings are lubricated and sealed – periodic lubrication is not required.

Upper Wheel Bushing – six to eight drops of oil each week.

Pivot Points, Shafts, and Bearing areas – six to eight drops of oil each week.

Coolant

Change coolant on a frequency appropriate to the type of coolant being used. Oil based coolants can sour. Refer to the coolant supplier's instructions for change frequency.

The general-purpose coolant is a mixture of water-soluble oil and water. Mix one part of soluble oil to ten parts of water (one quart of oil to ten quarts water). The eleven quarts of coolant is the amount required for the coolant pump to operate properly.

There are numerous coolants on the market that are formulated for special applications. Consult your local distributor for details in the event you have a long range production task, or are required to cut some of the more exotic materials.

Troubleshooting

Fault	Probable Cause	Suggested remedy
Excessive blade breakage	<ol style="list-style-type: none"> 1. Material loose in vise. 2. Incorrect speed or feed. 3. Teeth too coarse for material. 4. Incorrect blade tension. 5. Saw blade is in contact with workpiece before the saw is started. 6. Blade rubs on the wheel flange. 7. Misaligned guides. 8. Cracking at weld. 	<ol style="list-style-type: none"> 1. Clamp work securely. 2. Check Machinist's Handbook for speed/feed appropriate for the material being cut. 3. Check Machinist's Handbook for recommended blade type. 4. Adjust blade tension to the point where the blade just does not slip on the wheel. 5. Start the motor before placing the saw on the workpiece. 6. Adjust blade tracking. 7. Adjust guides. 8. Longer annealing cycle.
Premature blade dulling	<ol style="list-style-type: none"> 1. Blade teeth too coarse. 2. Blade speed too high. 3. Inadequate feed pressure. 4. Hard spots in workpiece or scale on/in workpiece. 5. Work hardening of material (especially stainless steel). 6. Insufficient blade tension. 7. Operating saw without pressure on workpiece. 	<ol style="list-style-type: none"> 1. Use a finer tooth blade. 2. Try a lower blade speed. 3. Decrease spring tension. 4. Increase feed pressure (hard spots). Reduce speed, increase feed pressure (Scale). 5. Increase feed pressure by reducing spring tension. 6. Increase tension to proper level. 7. Do not run blade at idle in/on material.
Bad cuts (crooked)	<ol style="list-style-type: none"> 1. Workpiece not square with blade. 2. Feed pressure too fast. 3. Guide bearings not adjusted properly. 4. Inadequate blade tension. 5. Span between the two blade guides too wide. 6. Dull blade. 7. Incorrect blade speed. 8. Blade guide assembly is loose. 9. Blade guide bearing assembly loose. 10. Blade track too far away from wheel flanges. 11. Guide bearing worn. 	<ol style="list-style-type: none"> 1. Adjust vise so it is square with the blade. (Always clamp the workpiece tightly in the vise.) 2. Decrease pressure. 3. Adjust guide bearing clearance to 0.001 inch (0.002 inch maximum). 4. Gradually increase blade tension. 5. Move blade guide bracket closer to work. 6. Replace blade. 7. Check blade speed (refer to Figure 5). 8. Tighten blade guide assembly. 9. Tighten blade guide bearing assembly. 10. Adjust blade tracking. 11. Replace worn bearing.

Fault	Probable Cause	Suggested remedy
Bad cuts (rough)	<ol style="list-style-type: none"> 1. Blade speed too high for feed pressure. 2. Blade is too coarse. 	<ol style="list-style-type: none"> 1. Reduce blade speed and feed pressure. 2. Replace with finer blade.
Blade is twisting	<ol style="list-style-type: none"> 1. Blade is binding in the cut. 2. Blade tension too high 	<ol style="list-style-type: none"> 1. Decrease feed pressure. 2. Decrease tension on Blade
Unusual wear on side/back of blade	<ol style="list-style-type: none"> 1. Blade guides worn 2. Blade guide bearings not adjusted. 3. Blade guide bearing bracket is loose. 	<ol style="list-style-type: none"> 1. Replace blade guides. 2. Adjust blade guide bearings. 3. Tighten blade guide bearing bracket.

Parts

Saw Stand and Bed

Index No.	Part No.	Description	Size	Qty
1-1	TS-1499141	Hex Cap Screw	M12x80	4
1-2	TS-1540081	Hex Nut	M12	8
2-1	J-7015-2-1	Coolant Pan		1
2-2	J-7015-2-2	Right Leg		1
2-3	J-7015-2-3	Left Leg		1
2-4	J-7015-2-4	Front Panel/Shelf		1
2-6	TS-0050031	Hex Cap Screw	1/4"-20x3/4	8
2-7	TS-0680021	Flat Washer	1/4"	16
2-8	TS-0561011	Hex Nut	1/4"-20	8
2-9	TS-0060051	Hex Cap Screw	3/8"-16x1	8
2-10	TS-0680041	Flat Washer	3/8"	16
2-11	TS-0561031	Hex Nut	3/8"-16	8
2-12	TS-1490071	Hex Cap Screw	M8x40	8
2-13	TS-0680031	Flat Washer	5/16"	16
2-14	TS-1540061	Hex Nut	M8	8
3	7015-3	Screen		1
4	TS-2246102	Button Head Socket Screw	M6x10	1
5S		Electrical Box Assembly (Reference Only)		1
6-1	7015-6-1	Coolant Tank		1
6-2	7015-6-2	Hose	13x19-350mm	1
6-3	7015-6-3	Elbow	PT1/2x1/4"	1
6-4	J-7015-6-4	Coolant Pump	1/8HP,115/230V,1Ph	1
6-5	TS-0680021	Flat Washer	1/4"	4
6-6	TS-081F052	Pan Head Machine Screw	1/4"-20x3/4	4
7	7015-7	Pivot Shaft		1
8S	7015-8S	Cylinder Assembly		1
9	7015-9	Ext. Retaining Ring	S18	1
12	J-7015-12	Cylinder Upper Bracket		1
13	TS-0720081	Lock Washer	5/16"	3
14	TS-1504061	Socket Head Cap Screw	M8x30	3
15	TS-1505081	Socket Head Cap Screw	M10x50	1
	7015-16S	Stock Stop Assembly (Index 16-2 thru 16-9)		1
16-2	TS-1523031	Socket Set Screw	M6x10	1
16-3	7015-16-3	Stop Rod		1
16-4	7015-16-4	Knob		1
16-5	TS-0720071	Lock Washer	1/4"	1
16-6	7015-16-6	Stop Arm		1
16-7	7015-16-7	Stop Bracket		1
16-8	TS-1540071	Hex Nut	M10	1
16-9	TS-1491031	Hex Cap Screw	M10x25	1
17-1S	7015-17-1S	Handwheel		1
17-2	TS-0680051	Flat Washer	7/16"	1
17-3	7015-17-3	Key	5x5x15L	1
17-4	7015-17-4	Acme Leadscrew		1
17-5S	7015-17-5S	Acme Nut Assembly		1
17-6	7015-17-6	Bracket		1
17-7	7015-17-7	Pin		1
24	TS-1505031	Socket Head Cap Screw	M10x25	2
24-1	TS-2361101	Lock Washer	M10	2
25	7015-25	Pivot Shaft Washer		2
26-1	7015-26-1	Washer		1
29	7015-29	Position Set Bracket		1
30	TS-0680031	Flat Washer	5/16"	2

Saw Stand and Bed

Index No.	Part No.	Description	Size	Qty
31	TS-1490031	Hex Cap Screw	M8x20	2
32	J-7015-32	Rear Pivot Bracket		1
33	7015-33	Plate		1
34	TS-2361101	Lock Washer	M10	2
35	TS-1505051	Socket Head Cap Screw	M10x35	2
36	J-7015-36	Bed		1
37	TS-2245102	Button Head Socket Screw	M5x10	2
38	7015-38	Angle Scale		1
39	TS-1524021	Socket Set Screw	M8x10	1
40	TS-1540061	Hex Nut	M8	1
41	TS-1490081	Hex Cap Screw	M8x45	1
42	J-7015-42	Front Moveable Vise Jaw		1
43	7015-43	Bushing		1
44	TS-1550071	Flat Washer	M10	1
45	TS-1505051	Socket Head Cap Screw	M10x35	1
46	7015-46	Washer	ø10.5xø27xt3mm	1
47	7015-47	Bolt		1
48	7015-48	Socket Set Screw	M8x30	2
49	7015-46	Washer	ø10.5xø27xt3mm	1
50	7015-50	Locking Handle		1
51	J-7015-51	Rear Fixed Vise Jaw		1
52	TS-1523031	Socket Set Screw	M6x10	1
53	7015-53	Bushing		1
54	TS-1505051	Socket Head Cap Screw	M10x35	1
55	TS-0561031	Hex Nut	3/8"-16	1
56	TS-0680041	Flat Washer	3/8"	1
57	7015-57	Spring Bracket		1
58	7015-58	Spring Eye Bolt		1
59	7015-59	Spring		1
60	TS-0081031	Hex Cap Screw	5/16"-18x3/4"	1
61	TS-0680031	Flat Washer	5/16"	1
62	TS-0561021	Hex Nut	5/16"-18	1
71	7015-71	Limit Switch Holder		1
71-1	TS-1550041	Flat Washer	M6	2
72	TS-1534042	Pan Head Machine Screw	M6x12	2
73	7015-73	Limit Switch		1
74	TS-1550021	Flat Washer	M4	2
74-1	TS-1540021	Hex Nut	M4	2
75	TS-2284302	Pan Head Machine Screw	M4x30	2
117	7015-117	Pivot Shaft		1

Saw Stand and Bed – Parts Breakdown

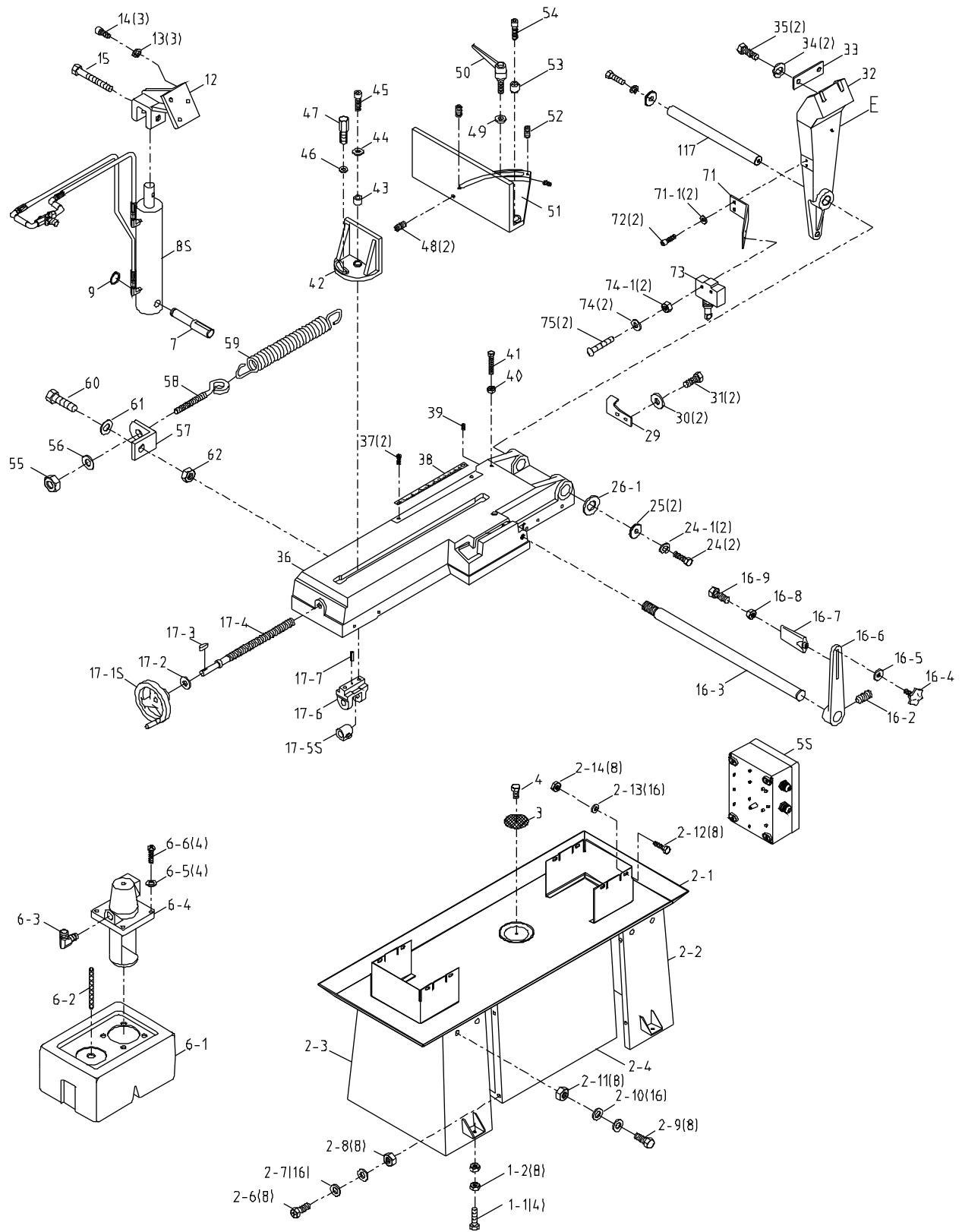

JET-813-060320-A-R1

Saw Head

Index No.	Part No.	Description	Size	Qty
200	J-7015-200	Blade Guard		2
201	7015-201	Direction Label		1
202	TS-2246102	Knob		2
204	TS-1504051	Socket Head Cap Screw	M8x25	2
205	TS-1551061	Lock Washer	M8	2
206	TS-1550061	Flat Washer	M8	2
207	7015-207	Knob		2
208	TS-1550071	Flat Washer	M10	2
209	J-7015-209	Blade Guide Support Arm		2
209-1	7015-209-1	Blade Direction Label		2
210	7015-210	Gib		2
211	7015-211	Ext. Retaining Ring	ø8	4
212	BB-608ZZ	Bearing	608ZZ	10
213	7015-213	Eccentric Guide		2
214	7015-214	Eccentric Guide		2
215	TS-1503051	Socket Head Cap Screw	M6x20	4
216	7015-216	Carbide Blade Guide		4
217	7015-217	Bearing Shaft		2
218	TS-1523011	Socket Set Screw	M6x6	4
219	J-7015-219	Left Guide Bracket		1
220-1	7015-220-1	Valve		2
220-2	7015-220-2	Hose	ø6	2
220-3	7015-220-3	Straight Connector		2
220-4	7015-220-4	Hold Down Clamp		2
220-5	TS-2361061	Lock Washer	M6	4
220-6	TS-2246122	Button Head Socket Screw	M6x12	4
221	J-7015-221	Right Guide Bracket		1
	7015-222S	Brush Assembly (Index 222-1 thru 222-5)		1
222-1	7015-222-1	Brush Holder		1
222-2	7015-222-2	Blade Brush		1
222-3	TS-1550041	Flat Washer	M6	2
222-4	TS-1540041	Hex Nut	M6	2
222-5	TS-1482071	Hex Cap Screw	M6x35	1
223	TS-2246122	Button Head Socket Screw	M6x12	1
223-1	TS-2361061	Lock Washer	M6	1
224	TS-2246122	Button Head Socket Screw	M6x12	2
225	J-7015-225	Blade/Brush Guard		1
226	TS-1540041	Hex Nut	M6	2
300	TS-1504031	Socket Head Cap Screw	M8x16	4
301	7015-301	Handle		2
302	7015-302	Knob		2
302-1	TS-1550031	Flat Washer	M5	6
302-2	TS-2245102	Button Head Socket Screw	M5x10	6
303	J-7015-303	Left Blade Wheel Cover		1
304	TS-2361081	Lock Washer	M8	4
305	TS-1540061	Hex Nut	M8	4
306	J-7015-306	Right Blade Wheel Cover		1
306-1	7015-306-1	Padding Strip		2
307	TS-1490031	Hex Cap Screw	M8x20	1
308	7015-308	Washer	ø16xø30xt3mm	1
309	BB-6205VV	Bearing	6205-2RS	2
310	7015-310	Idler Wheel		1
311	7015-311	Shaft		1
312	7015-312	Handle		1
313	TS-0561031	Hex Nut	3/8"-16	2
314	J-7015-314	Body Frame		1

Saw Head

Index No.	Part No.	Description	Size	Qty
314-1	7015-314-1	Connector	PT1/2"	1
314-2	7015-314-2	Hose	18x24-190mm	1
314-3	7015-314-3	Stop Bolt		1
314-4	TS-1540061	Hex Nut	M8	2
314-5	7015-314-5	Screen		1
315	J-7015-315	Upper Cover		1
315-1	7015-315-1	Knob		2
316	7015-316	Scale		1
316-1	7015-316-1	Rivet	ø2x5L	2
317	TS-1506011	Socket Head Cap Screw	M12x20	2
318	7015-318	Slide Bar		1
319	TS-1524051	Socket Set Screw	M8x20	4
320	TS-1492021	Hex Cap Screw	M12x30	1
321	TS-2361121	Lock Washer	M12	1
322	7015-322	Drive Shaft Washer		1
323	7015-323	Key	8x8x30L	1
324	5516192	Blade (Standard)	1x.035x114.5" - 5/8T	1
	5516191	Blade	1x.035x114.5" - 4/6T	1
325	7015-325	Drive Wheel		1
326	TS-1505021	Socket Head Cap Screw	M10x20	3
327	TS-1551071	Lock Washer	M10	3
328	J-7015-328	Gear Box Assembly	1:30 8mm	1
329	TS-1540071	Hex Nut	M10	2
330	7015-330	Shaft		1
330-1	7015-330-1	Knurled Disc		1
331	TS-1540081	Hex Nut	M12	1
332	TS-1505101	Socket Head Cap Screw	M10x60	1
333	7015-333	Motor Adjusting Screw		1
334	7015-334	Motor Mount Plate		1
335	7015-335	Motor Mount Plate Bracket		2
336	TS-1550041	Flat Washer	M6	4
337	TS-1503051	Socket Head Cap Screw	M6x20	4
338	J-7015-338	Motor	1.5HP, 115/230V, 1PH	1
339	7015-339	Key	6x6x35L	1
340	TS-1550061	Flat Washer	M8	4
341	TS-1490021	Hex Cap Screw	M8x16	4
342	TS-1482011	Hex Cap Screw	M6x10	3
343	TS-1550041	Flat Washer	M6	3
345S	J-7015-345S	Pulley Guard & Cover Assembly		1
345-1	7015-345-1	Knob		1
345-2	TS-1550041	Flat Washer	M6	1
345-3	7015-345-3	Bracket		1
345-4	TS-1482011	Hex Cap Screw	M6x10	1
348	7015-348	Gearbox Pulley		1
349	TS-1524021	Socket Set Screw	M8x10	2
350	VB-A32	Belt	A-32	1
351	7015-351	Motor Pulley		1
352	TS-1524021	Socket Set Screw	M8x10	2
353	7015-353	Speed Chart Label		1
354-1	7015-354-1	Hose Clamp	ø12	2
354-2	7015-354-2	Straight Connector	PT1/4"x1/4"	1
354-3	7015-354-3	Elbow	PT1/4"x1/4"	1
354-4	7015-354-4	Hose Clamp	ø19	2
354-5	7015-354-5	Hose	ID1/4"x2.2tx80cm	1
354-6	7015-354-6	3 Way Coolant Block		1
354-7	7015-354-2	Straight Connector	PT1/4"x1/4"	1

Saw Head

Index No.	Part No.	Description	Size	Qty
354-8	TS-1503071	Socket Head Cap Screw	M6x30	2
354-9	7015-354-9	Hose	ID1/4"x2.2tx143cm	1
354-10	7015-354-10	Hose	ID1/4"x2.2tx32cm	1
355	7015-355	Hub		1
355-1	7015-355-1	Blade Tension Handle		2
356	BB-51203	Thrust Bearing	51203	1
357	7015-357	Tension Indicator		1
358	7015-358	Lock Washer, Tension	ID16.3x31.5x1.8t	10
359	7015-359	Tension Shaft		1
360	J-7015-360	Tension Slide Base		1
360-1	7015-360-1	Tension Scale		1
361	TS-1523051	Socket Set Screw	M6x16	1
362	J-7015-362	Tension Slide Block		1
363	TS-154010	Hex Nut	M16	1
364	7015-364	Washer		1
365	TS-1490031	Hex Cap Screw	M8x20	1
366	7015-366	Screw		3
367	TS-2361101	Lock Washer	M10	3
368	TS-1491101	Hex Cap Screw	M10x60	3
369	7015-369	Plate		2
370	TS-2361081	Lock Washer	M8	4
371	TS-1490011	Hex Cap Screw	M8x12	4
372	TS-2246122	Button Head Socket Screw	M6x12	2
373	TS-0680021	Flat Washer	1/4"	2
374	J-7015-374	Control Box		1
375	TS-2286121	Flat Head Machine Screw	M6x12	2
376	7015-376	Control Box Front Panel	5 Hole	1
377	TS-1533032	Pan Head Machine Screw	M5x8	8

Saw Head – Parts Breakdown

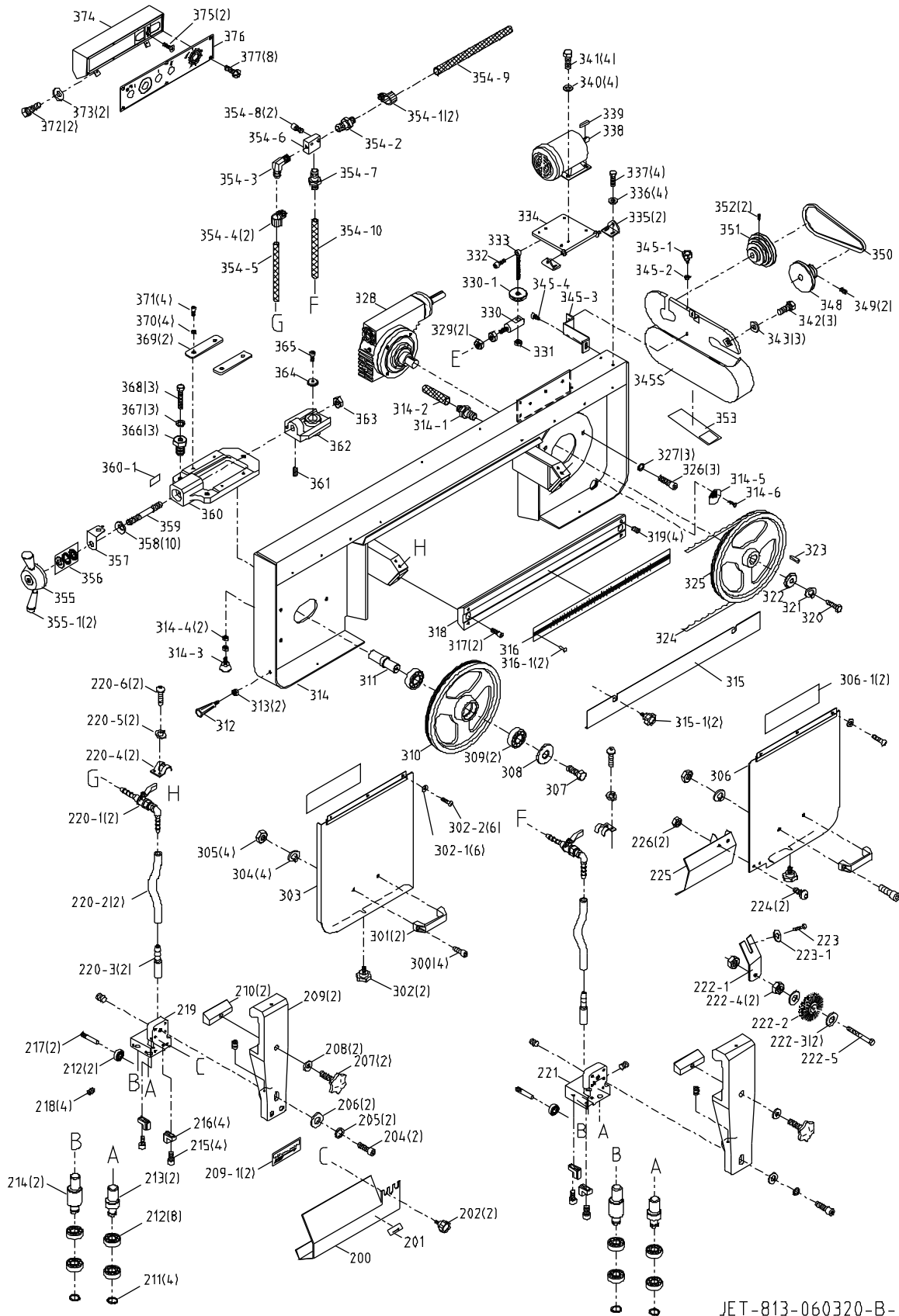

JET-813-060320-B-R1

Electric Assembly – Parts and Breakdown

Index No.	Part No.	Description	Size	Qty
5-1	7015-5-1A	Fuse Base (<i>serial no12040936 and higher</i>)	VLC10	2
5-3	7015-5-3A	Fuse (<i>serial no12040936 and higher</i>)	KTK-2A	1
5-4	7015-5-4	Magnetic Contactor	SDE MA-15	1
5-5	7015-5-5	Emergency Stop Switch	HY-57B	1
5-6	7015-5-6A	Limit Switch (<i>serial no12040936 and higher</i>)	CSA/CUS	1
5-7	7015-5-7	Flat Switch (Start)	XB7-EA311AG	1
5-8	7015-5-8	Selector Switch (Coolant Pump)	XB7-ED21	1
5-9	7015-5-9	Indicator Light (Power)	XB7-EV64	1
5-10	7015-5-10	Transformer	CE 30W 110/220V	1
5-11	7015-5-11	Cable Setting Nut	PG-11	4
5-12	7015-5-12	Cable Setting Nut	PG-13.5	1
5-14	7015-5-14	Electrical Control Box Cover		1
5-15	7015-5-15	Electrical Control Box		1
5-16	7015-5-16	Net Plate		1
5-20	7015-5-20	Screw, Tapping	M4x8L	14
5-21	TS-1550031	Washer	M5	3
5-22	TS-1533032	Pan Head Machine Screw	M5x10	3
5-24	7015-5-24	Motor Cable	14*3C	1
5-25	7015-5-25	Power Cable	14*3C	1
5-26	7015-5-26	Limit Cable	VDE0.75*2C	1
5-27	7015-5-27	Pump Cable		1
5-28	7015-5-28	Limit Switch Cover	CB2	1
5-29	7015-5-29	Control Wire	0.75 x 6C	1
5-30	TS-1533032	Pan Head Machine Screw	M5x10	4
5-31	7015-5-31	Feed Rate Control Knob		1
5-32	7015-5-32	Overload Relay (<i>serial no12040936 and higher</i>)	RHU-10K1	1

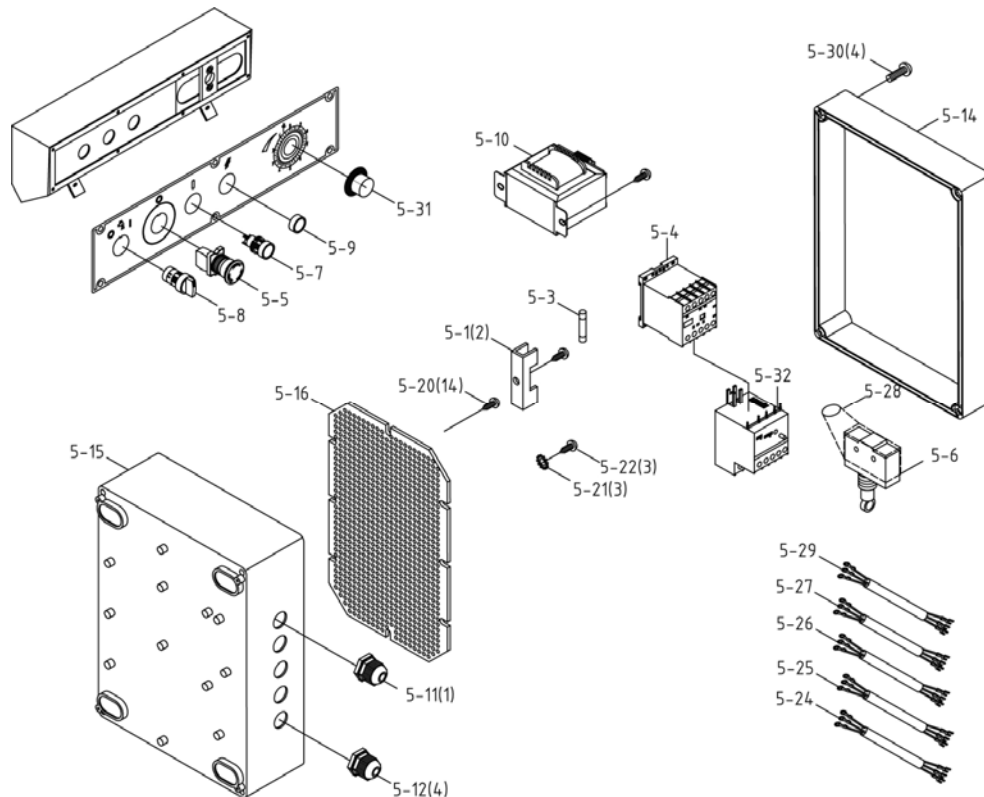

Wiring Diagram

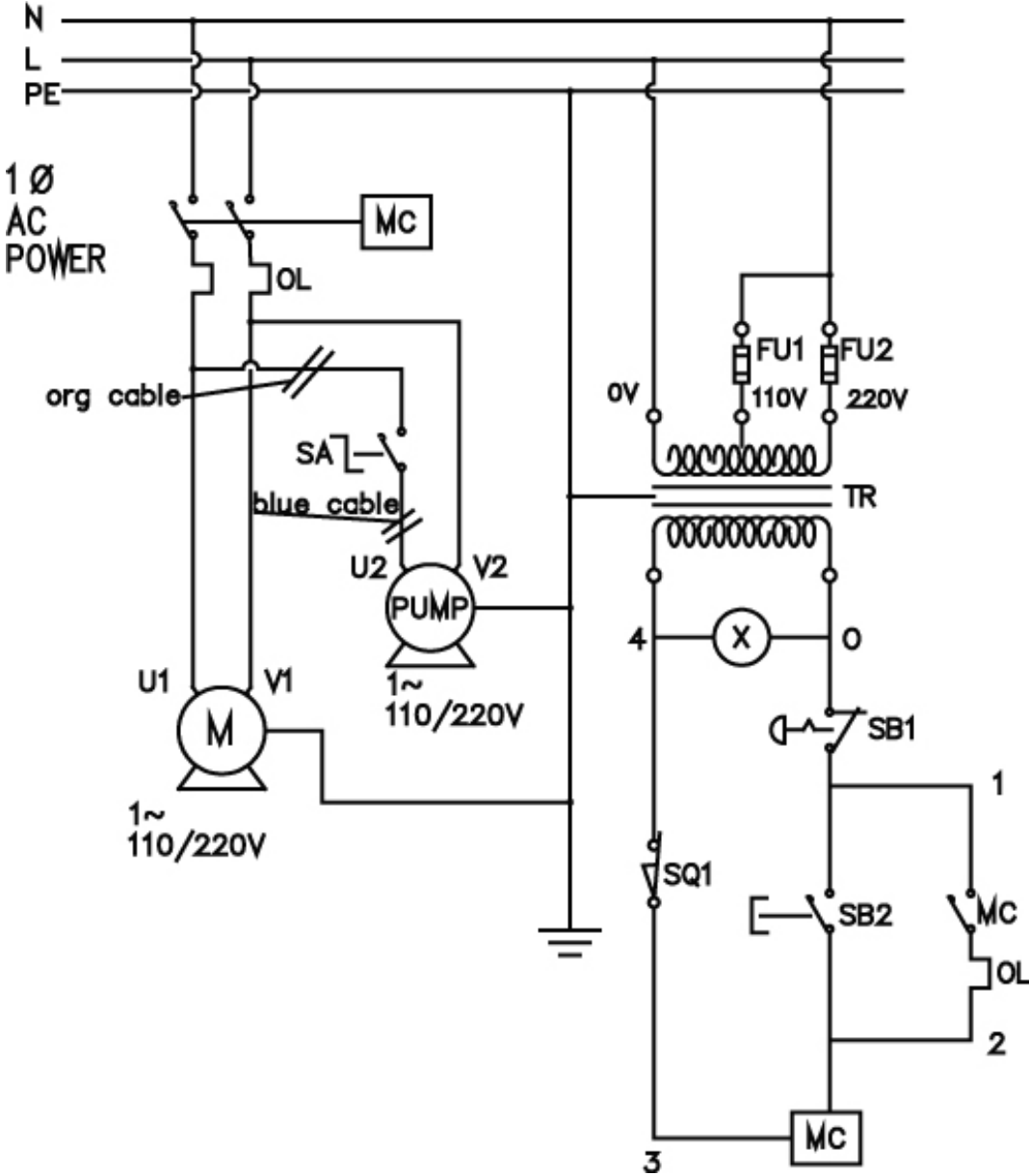

Ordering Replacement Parts

To order parts or reach our service department, call 1-800-274-6848 Monday through Friday (see our website for business hours, www.waltermeier.com). Having the Model Number and Serial Number of your machine available when you call will allow us to serve you quickly and accurately.



WALTER MEIER (Manufacturing) Inc.

427 New Sanford Road
LaVergne, Tennessee 37086
Phone: 800-274-6848
www.waltermeier.com