

ULTRA JACK
MODEL # 2000

PLANKS / GUARDRAILS ARE NOT INCLUDED

ULTRA-JACK SYSTEM

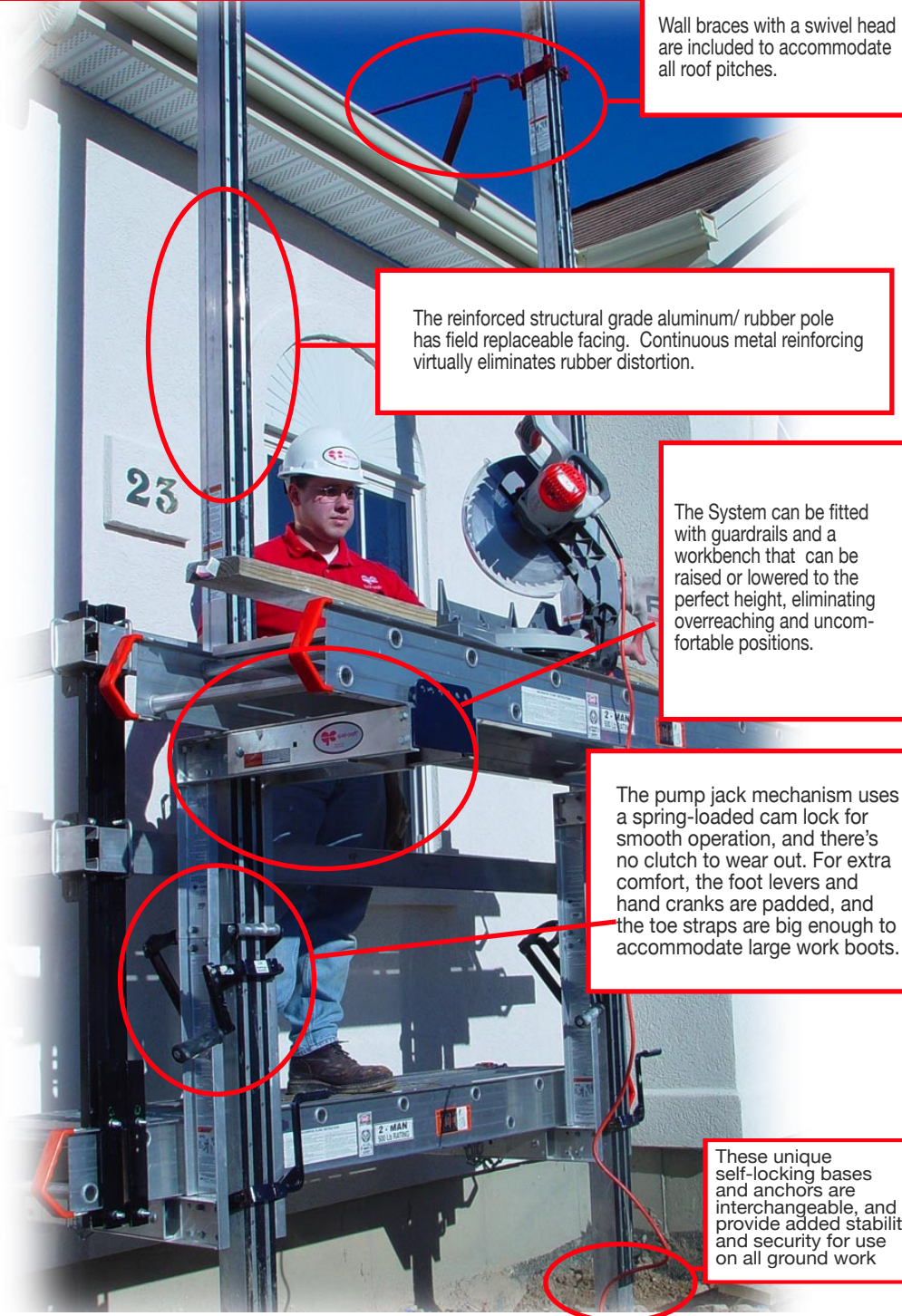

Wall braces with a swivel head are included to accommodate all roof pitches.

The reinforced structural grade aluminum/ rubber pole has field replaceable facing. Continuous metal reinforcing virtually eliminates rubber distortion.

The System can be fitted with guardrails and a workbench that can be raised or lowered to the perfect height, eliminating overreaching and uncomfortable positions.

The pump jack mechanism uses a spring-loaded cam lock for smooth operation, and there's no clutch to wear out. For extra comfort, the foot levers and hand cranks are padded, and the toe straps are big enough to accommodate large work boots.

These unique self-locking bases and anchors are interchangeable, and provide added stability and security for use on all ground work

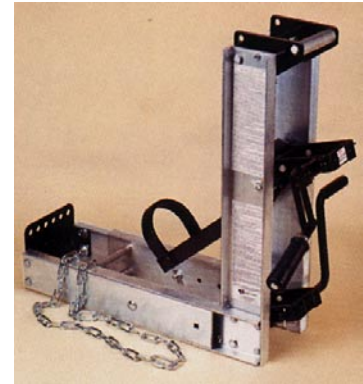

Ultra Jack System
Model # 2000

Qual-Craft Industries offers a new line of pump jack scaffolding called the Ultra-Jack System. This amazing, new, state-of-the-art system is easier to operate than the older styles. Much of the effort in operating a pump jack system can be used up in the mechanism if it doesn't operate smoothly. Frustration and unnecessary use of energy are not conducive to a productive and safe work environment. You won't believe the smooth action and easy operation of the Ultra-Jack System.

The time saved in setting-up and taking-down, the ease of operation, and the convenience of transporting a system designed to be easy to transport, means more time spent doing the job. The Ultra-Jack System also includes new aluminum poles with metal reinforced rubber facing, which offer more rigidity and superior strength over wood poles. The Ultra-Jack poles are easily joined together in two 24-foot sections allowing up to 48 feet in height. The poles can be fitted with two types of bases to accommodate any ground work surface. The non-skid base works well for flat and hard surfaces, and the spiked anchors offer security on soft or uneven surfaces. The poles are equipped with a field replaceable rubber facing that ensures "grab" as the jacks move up and down.

The whole System is easily handled and pick-up friendly, making it a breeze to transport, once again saving time and labor costs. An important part of this next generation scaffolding is the aluminum planks. Their extra strength allows for a greater span between poles, providing access to more area. The Ultra-Jack System can be outfitted with a versatile workbench, which can be installed as needed at any time during the job, without

Product Specifications

Model #	2000
Description:	Ultra Jack
Unit Pack:	1 / Carton
Weight per Pack:	32 Pounds
Cu. Ft. per Pack:	2.9 cu. ft.



Customer Support and Ordering Information

781-344-1000 • www.qualcraft.com

ULTRAJACK SYSTEM

ULTRA-JACK MODEL # 2000



removing the Ultra-Jack from the pole, or requiring any disassembly. The workbench fastens right onto the poles, and can be a real time saver by providing a spacious work area to ensure that you take the right tools and supplies up the scaffolding with you, promoting productivity and efficiency. The workbench also insures safety by providing a secure place to carry tools and materials and prevent them from becoming a fall hazard to workers below. Another component of the Ultra-Jack System are the wall braces that feature a full swivel head to cover all possible roof pitches. These provide rigid, triangular bracing as required by OSHA. The positive spring loaded cam lock on the Ultra-Jack pump mechanism provides durability, smooth operation, and means that there is no clutch to wear out. The Ultra-Jack pump mechanism has a greater climbing rate per stroke than other available pump jacks, which allows for faster raising of the work platform, and since it requires less strokes and effort, results in less operator fatigue. The foot levers that activate the lowering mechanism, and hand crank handles that operate the lowering gear, are padded for extra comfort. The boot straps on the foot levers are big enough to accommodate large work boots.

Poles are available in 6, 12, and 24 ft. lengths. Join any two pole lengths together using a pole connector, allowing a scaffold system to reach a working height of 18 ft., 24 ft., 30 or 48 ft. The use of aluminium walk planks with guardrails allows for wider spans between poles.

ULTRAJACK WORK BENCH

Usage Ideas & Options

The Ultrajack system is a completely integrated system designed to maximize your productivity and safety. The system is configurable with a variety of options that accommodate multiple configurations and nearly any project environment.

- ULTRA-JACK BRACE model #2002
- ULTRA-JACK WORK BENCH model #2004
- ULTRA-JACK POLE ANCHOR model #2008
- ULTRA-JACK POLE BASE model #2009



POLE ANCHOR



POLE BASE



ULTRA-JACK BRACE

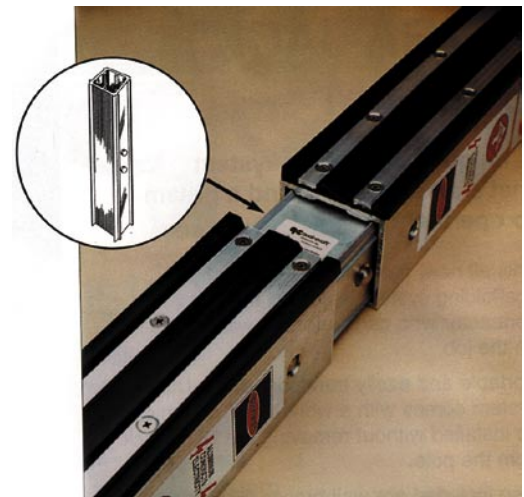

Customer Support and Ordering Information

781-344-1000 • www.qualcraft.com

INSTRUCTIONS FOR INSTALLATION, USE AND MAINTENANCE OF THE QUAL-CRAFT ULTRA-JACK™ SYSTEM

INSTALLATION OF THE QUAL-CRAFT® ULTRA-JACK®

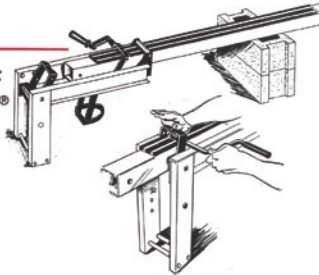

INSTALLATION OF BRAKE ASSEMBLY

- A) Slide brake pedal rod through square holes. The rod should go through holes on both sides of the brake mechanism.
- B) Slide the cotter pin through the small hole at the end of the brake pedal rod and bend as indicated to prevent the rod from sliding out of position.

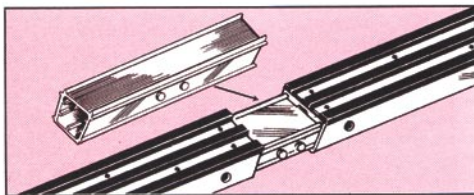
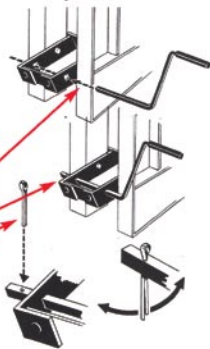

ASSEMBLY OF THE QUAL-CRAFT® ULTRA-JACK® ALUMINUM/RUBBER POLE

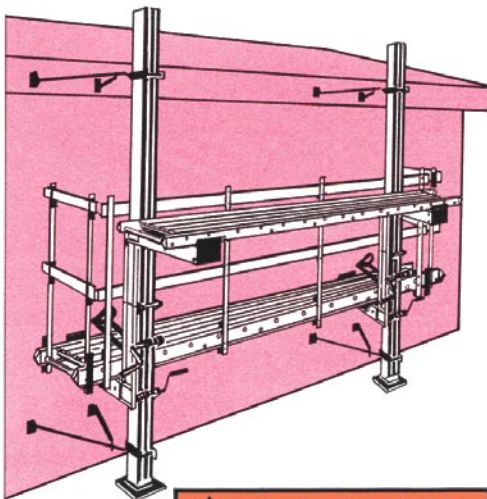

WARNING
Failure to read and follow instructions on the use of this product could result in serious personal injury. This product must be used in strict compliance with Local, State & Federal OSHA Regulations. Be safety conscious.

Installation of the Qual-Craft Ultra-Jack™

The Ultra-Jack should be installed onto the Qual-Craft Ultra-Jack™ Aluminum/Rubber pole prior to the installation of the pole to the work wall. First place the Aluminum/Rubber Pole on the ground with the rubber surface facing downward. Slide the bottom of the pole (exposed aluminum end) through the top of the Ultra-Jack with the jack's platform retainer facing the sky. It may be necessary to pump the stirrup as you move the Ultra-Jack up from the bottom of the pole. Stop when the Ultra-Jack is approximately 1 foot up from the bottom of the pole.

Assembly of the Qual-Craft® Ultra-Jack™ Aluminum/Rubber Pole

- 1) Assemble two Ultra-Jack Aluminum/Rubber Poles by inserting the Ultra-Jack Pole Connector into one of the two Ultra-Jack Aluminum/Rubber Poles so that the button locks located on the Pole Connector are lined up with the corresponding holes located approximately two inches in from the end of each pole. It will be necessary to depress the button locks prior to inserting the Pole Connector so that they can glide just inside the pole until reaching the corresponding holes in the pole. Check to insure that the buttons snap securely into the holes locking the connector into position. Slide the second pole over the remaining exposed section of the Pole Connector in the same way, insuring that the button snap into the holes on the pole. Inspect to insure that the rubber surfaces abut each other without a gap.
- 2) Position the pole along the work wall. Use a Qual-Craft Pole Anchor or Rubberized Base Plate at the bottom of the pole. Place pole on firm level ground. Do not use on unstable base, on top of other scaffolds or on roof surfaces. Using a Qual-Craft Ultra-Jack Brace, secure the pole to the work wall at the bottom and the top of the pole and at other points as necessary. For poles longer than 24 feet, install intermediate bracing every 12 feet. Poles must be plumb. The rubber surface of the pole should face out from the work wall. The round bar of the brace should be fastened to work wall at a right angle to the pole. The angle bar of the brace should then be fastened to the right or left as desired. The spread between the brace arms is 32" thus enabling installation on studs 16" on center.
- 3) Additional poles should be spaced based on the type and style walk planks used. See "Choosing a Walk Plank" below. Additional poles should be installed in the same manner as the first pole above.

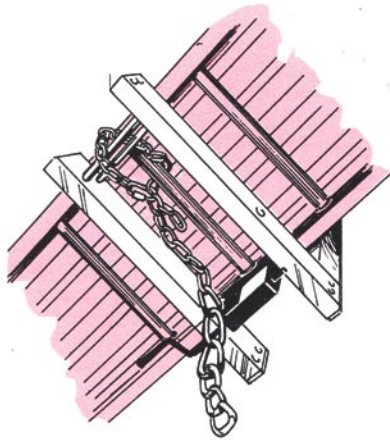

Choosing a Walk Plank:

- 1) Wood walk planks shall be made of Scaffold Grade or equivalent lumber. When fabricated from 2 inch full thickness, undressed lumber the maximum span between supports shall not exceed 9 feet. When fabricated from 2 inch nominal thickness lumber the maximum span between supports shall not exceed 7 feet.
- 2) Aluminum walk planks must have been manufactured for that purpose and shall not exceed 24 feet in length.
- 3) All walk planks shall be overlapped a minimum of 12 inches and secured from movement except when using aluminum walk planks designed to be fastened together. For this style walk plank the joint must be secured in place directly over the Ultra-Jack support arm.
- 4) All scaffold planks must extend no less than 6 inches and no more than 12 inches over the support arms.
- 5) OSHA regulations require that the platform to be fully decked and that the minimum width be 12 inches.

Installing a Walk Plank:

- 1) Extend the platform arm of each Ultra-Jack to the actual width of the work platform and secure in place by tightening the fasters along the side of the adjustable arm.
- 2) Place appropriate decking between the two Ultra-Jack scaffolds. See "Choosing a Walk Plank" above.
- 3) Walk planks should overhang the Ultra-Jack platform arm 12 inches on each end. When using more than two walk planks to complete a system installation, overlap and secure walk planks to each other with 12 inches of overlap on each walk plank as required by OSHA.
- 4) Secure walk planks to Ultra-Jack with the chains attached to each platform arm, passing chain over and then under rungs and securing to Ultra-Jack with hardware provided. A padlock may be used for added security.
- 5) Always erect the scaffolding system so that the working or standing platform is level.
- 6) Install Qual-Craft Ultra-Jack Guardrails and End Rails as required by law.

Installing a Guardrail System:

- 1) Install a guardrail support arm to the walk plank at each of the outside corners and along the length of the walk in increments of 8 feet or less.
- 2) Install aluminum guardrails at both the top and mid-rail holders for the full length of the walk platform and secure in place.
- 3) Install toe boards along the length of the walk plank and secure in place.
- 4) Install End Rail system (top, mid-rail and toe boards) at each end of the walk platform.

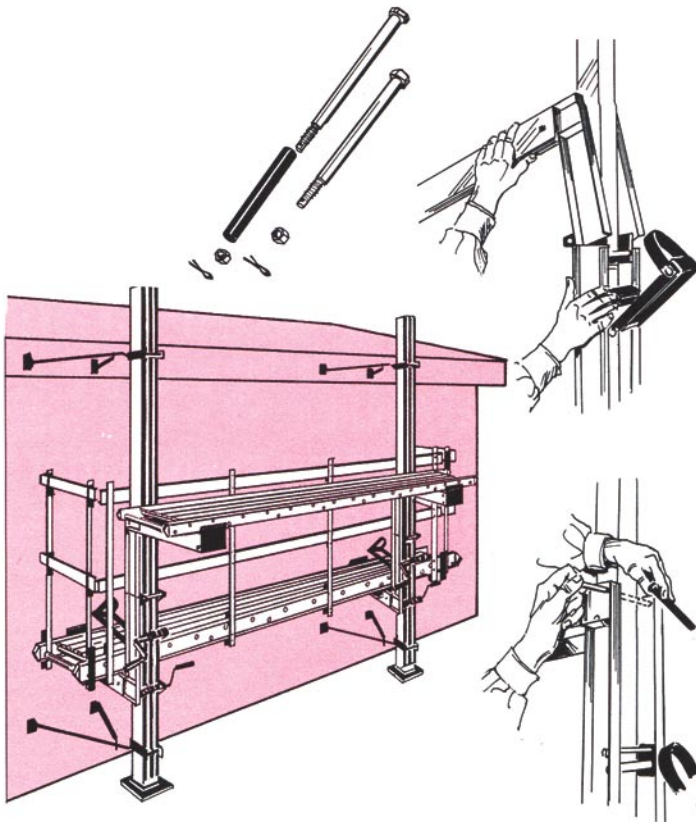

Install Workbench:

- 1) Install bracket in accordance with instructions provided with the work bench attachment.
- 2) The installation of a workbench does not substitute for the upper guardrail as required by Federal OSHA Regulations.
- 3) Do not stand on the workbench or use for any purpose other than providing a work space for tools and materials.

Instructions for using the Qual-Craft® Ultra-Jack™

To Raise the Ultra-Jack™:

- 1) Stand on the walk plank with the jack and pole in front of you. Lock the crank handle by turning the handle until the spring lock engages. (Fig. #2)
- 2) Place your foot in the stirrup and pump slowly until the platform is raised approximately 1 foot (Fig. #3).
- 3) Repeat this process with other Ultra-Jacks. Always keep the work surface level.
- 4) Lock the Jack by placing the stirrup in the "UP" position. (fig. #1)

To Lower the Ultra-Jack™:

- 1) With your back to the work wall, face the pole and raise the stirrup to the "UP" position. (Fig. #1)
- 2) Insure that the crank handle is in the locked position. (Fig. #2)
- 3) Holding onto the pole, place one foot on the square pedal of the lower lock, press down and hold open.
- 4) Take hold of the crank handle pulling the arm out to the right and begin turning the handle until the platform begins to lower (Fig. #4).
- 5) Continue lowering the platform for approximately one foot.
- 6) Lock the Ultra-Jack by turning the handle until the lock ring is seated and the handle is no longer under spring tension. Release the square pedal to re-engage the lower safety lock.
- 7) Repeat procedure with the other jacks until work platform reaches desired height. Always keep work surface level.

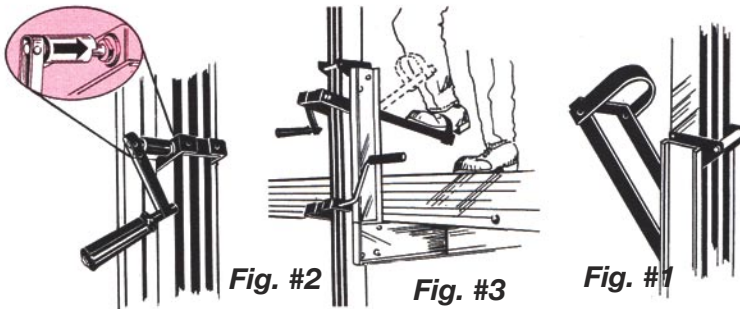

TO RAISE THE ULTRA-JACK® PLATFORM

TO LOWER THE ULTRA-JACK® PLATFORM:

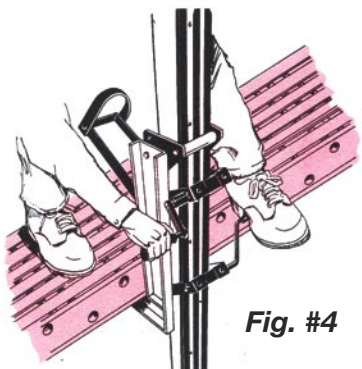

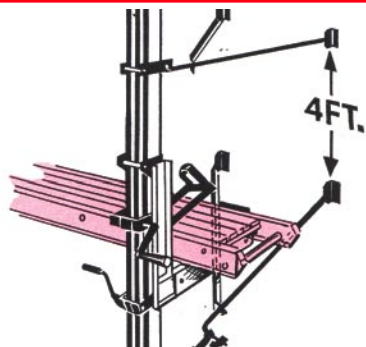

To Pass an Ultra-Jack Brace:

- 1) When passing an Ultra-Jack Brace that is already installed, an extra brace should be installed approximately 4 feet above the one to be passed until the original brace is reinstalled.
- 2) After installing the temporary brace, loosen the wing nut and allow the brace to be passed to swing clear of the pole. Do not remove from wall. After brace has been passed, reconnect it to pole and remove the extra brace.

WARNING

Failure to read and follow instructions on the use of this product could result in serious personal injury.

To prevent an unstable scaffold that could lead to serious personal injury:

- Use only Qual-Craft® Ultra-Jack™ products as part of this system. Do not use with other manufacturers' pump jacks, poles or accessories.
- Do not use with wood poles.
- Do not use above 48 feet or with more than two poles of any length joined together.
- Poles must be secured with rigid triangular steel bracing at top, bottom and at points in-between in accordance with instructions.
- Do not use without guardrails, mid-rails, toe-boards and or fall-arrest system.
- Do not use a workbench as a substitute for the requirement of a guardrail system.

OSHA requires that the user have knowledge of all regulations that apply to the use and care of this product and that the employer must provide training.

This product must be used in strict compliance with Local, State, & Federal OSHA Regulations.

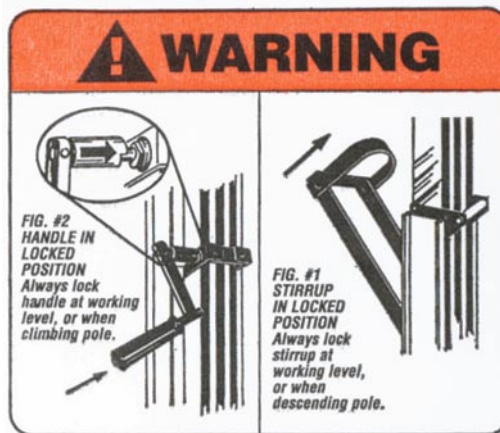

Care and Use of the Ultra-Jack Scaffold System:

- 1) Prior to use the user should inspect the installation to insure that the system is properly set up and ready for use.
- 2) Do not use equipment if wet or frozen.
- 3) Oil crank handle bushings as necessary.
- 4) An access ladder shall provide safe access to the work platform.
- 5) Ultra-Jack Scaffolding must not be used over 48 feet off the ground.
- 6) There should never be more than two people on an Ultra-Jack System between any two poles.
- 7) Only one walk plank shall be supported between any two poles.
- 8) Additional safety accessories such as guardrails, mid-rails, toe-boards, fall arrest or harness systems must be used as required by OSHA Regulations.

WARNING

- Inspect all Ultra-Jack equipment before and after each use. Be sure that there is no damage or deformation to any of the equipment.
- Inspect the rubber surface of the pole before and after each use for worn or damaged surface, replace if necessary with Qual-Craft replacement components.
- When joining two poles always inspect splices to insure that there is no gap between rubber surfaces.

Capacity:

Pump Jack scaffolding should not carry more than two people or 500 pounds between any two poles. This considers a 4:1 safety factor as required by OSHA Standards when installed and used in accordance with the instructions. When used in accordance with instructions this product meets U.S. Department of Labor OSHA Regulations

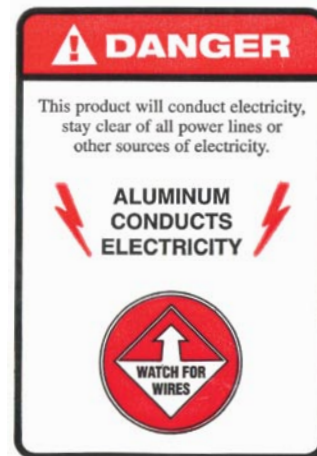

This Product must be used in strict compliance with Local, State and Federal OSHA Regulations. Be safety conscious.