

POWERHOUSE[®]

1000Wi Digital Inverter Generator



OWNER'S MANUAL
PLEASE READ THIS MANUAL
CAREFULLY BEFORE USING

Quick Start Guide



WARNING

- Use outdoors only. Generators produce carbon monoxide — a poisonous, colorless, odorless gas that can cause death or serious injury.
- Always operate on a level surface.
- Keep away from rain, snow or other wet conditions.
- Keep away from smoking materials, sparks, and other sources of combustion when refueling.

Pre-Operation

1. Add oil by removing the maintenance panel and inspecting the dipstick. Fill the oil reservoir with 8.5 oz. (250 ml) of oil or to the full mark on the dipstick. Use appropriate grade, high-detergent, premium quality, 4-stroke engine oil (synthetic or conventional). Use SAE 15W-40 viscosity oil unless operating at ambient temperatures below 32° F (0° C). For temperatures below 32° F, use SAE 0W-40 viscosity oil. Refer to the [Operating at extreme temperatures](#) section for more information.
2. Carefully add regular unleaded automotive gasoline up to the shoulder of the fuel strainer. To avoid spilling fuel, use care to not fill too quickly or over fill. Avoid getting dirt, dust, or water in the fuel tank. Do not use a blend that contains more than 10% ethanol. Do not use gasoline containing methanol. An octane rating of 87 or higher is recommended.



CAUTION

- Do not add 2-Stroke oil to your fuel. Doing so will void your warranty.



NOTE

- It is recommended that you use a fuel stabilizer, such as STA-BIL®, to help prevent fuel oxidation (breakdown) and the formation of gum and varnish, and to inhibit corrosion in the fuel system and carburetor.

Operation

1. Ensure that no loads have been connected to the AC receptacles.
2. Open the fuel valve.
3. Push the engine switch on the control panel to the “ON” position.
4. Move the choke lever to the “START” position.
5. Pull the starter grip lightly until resistance is felt, then pull briskly out. Repeat until the engine starts.
6. Move the choke lever to the “RUN” position after the engine warms up.
7. The green “RUN” light will illuminate when the generator is ready for use. Before connecting any loads, ground the generator with a length of heavy cable, connecting the generator’s grounding terminal to an external ground source.
8. Make sure that all appliances to be connected have been switched off and are in good working order. Confirm that the combined electrical rating of the appliances does not exceed that of the generator.
9. Connect the appliance to the appropriate receptacle on the generator’s control panel.
10. To minimize fuel consumption and noise, push the economy switch to the “ON” position. This setting regulates the engine’s speed so that it matches the needs of the connected loads. Do not use the economy setting if you are connecting items with electric motors that have a high amperage draw during startup or with appliances that cycle on and off rapidly.

Shutdown



NOTE

- In an emergency, pushing the Engine Switch on the control panel to the “OFF” position will automatically stop the engine with or without a load. However, repeatedly stopping the generator without disconnecting all loads can cause damage to the generator or appliances.

1. Turn off all connected appliances and disconnect from the generator.
2. Push the engine switch on the control panel to the “OFF” position.
3. Turn the fuel valve off.

PREFACE

Thank you for purchasing a POWERHOUSE® generator.

This manual covers operation and maintenance of POWERHOUSE® generator-model 1000Wi.

All information in this publication is based on the latest product information available at the time of printing.

We reserve the right to make changes at any time without notice and without incurring any obligation.

No part of this publication may be reproduced without written permission.

This manual should be considered a permanent part of the generator and should remain with it if it is resold.

Pay special attention to statements preceded by the following words:



- Indicates a strong possibility of severe personal injury or death if instructions are not followed.



- Indicates a possibility of personal injury or equipment damage if instructions are not followed.



- Gives helpful information.

If you have a problem with this generator, do not return it to the store where you purchased it. For warranty support call 877-544-4449 from 8am to 6pm ET, email us at warranty@powerhouse-products.com or send a fax to 800-263-0280.



- Failure to properly follow these precautions can result in property damage, serious injury, or DEATH!
- Read all labels and the Owner's Manual before operating this generator.
- Generators produce carbon monoxide — a poisonous, colorless, odorless gas that can cause death or serious injury.
- Indoor use of a generator can kill quickly. Generators should be used outdoors only.
- Generators should only be used outdoors away from garages and open windows, but protected from rain and snow.
- Check for spilled fuel or leaks. Clean and/or repair before use.
- Always stop engine before refueling. Wait 5 minutes before restarting.
- Keep any source of ignition away from fuel tank, at all times.
- The portable generator is not meant to be used as a permanent back-up power system for the home. A permanently installed stationary generator is designed to be safely used for this specific purpose.
- Our generators are designed to give safe and dependable service if operated according to instructions. Read and understand the Owner's Manual before operating the generator. Failure to do so could result in personal injury or equipment damage.

CONTENTS

1000Wi Digital Inverter Generator	1
Quick Start Guide	2
Pre-Operation	2
Operation	2
Shutdown	2
PREFACE	3
1. SAFETY INSTRUCTIONS.....	5
2. COMPONENT IDENTIFICATION	6
2.1 Control panel 1000Wi	7
2.2 Serial number and bar code identification and location.....	8
3. PRE-OPERATION CHECK.....	9
3.1 Check the engine oil level.....	9
3.2 Check the fuel level	10
3.3 Check the air cleaner.....	11
4. OPERATING INSTRUCTIONS.....	12
4.1 Starting the engine.....	12
4.2 High altitude operation.....	13
4.3 Operating at extreme temperatures.....	13
4.4 Generator use	14
4.5 AC application	15
4.6 Output and Overload Lights.....	15
4.7 DC application.....	16
4.8 Low oil alarm system	17
4.9 Economy switch.....	18
4.10 Stopping the engine.....	18
5. MAINTENANCE.....	19
5.1 Emission control system	19
5.2 Maintenance Schedule	21
5.3 Changing oil	22
5.4 Air cleaner service.....	23
5.5 Spark plug maintenance	24
5.6 Spark arrestor maintenance	25
6. TRANSPORTING and STORAGE.....	26
6.1 Transporting the generator	26
6.2 Short term storage of the Generator.....	26
6.3 Infrequent use.....	27
6.4 Exercising the Generator	27
7. TROUBLESHOOTING.....	28
7.1 Engine will not start.....	28
7.2 Appliance does not operate	29
7.3 No output at the DC receptacle	29
8. SPECIFICATIONS	30
9. WARRANTY AND CONSUMER INFORMATION.....	31
CALIFORNIA EMISSIONS CONTROL WARRANTY STATEMENT	32
EMISSION CONTROL SYSTEM WARRANTY	33
10. APPENDIX B - EMISSION CONTROL SYSTEM	34
11. APPENDIX C - SAFETY AND CHARGING INSTRUCTIONS	35

1. SAFETY INSTRUCTIONS



- This generator is designed to give safe and dependable service if operated according to instructions.
- Read and understand the Owner's Manual before operating the generator. Failure to do so could result in personal injury or equipment damage.



- Exhaust gas contains poisonous carbon monoxide. Never run the generator in an enclosed area.
- Be sure to provide adequate ventilation.



- The muffler becomes very hot during operation and remains hot for several minutes after stopping the engine.
- Be careful not to touch the muffler while it is hot.
- Let the engine cool before storing the generator indoors.

To ensure safe operation



- Gasoline is extremely flammable and explosive under certain conditions. Refuel in a well ventilated area with the engine stopped.
- Keep away from cigarette smoke and sparks when refueling the generator.
- Wipe up spilled gasoline at once.



- This generator is not intended, nor designed, for use as a standby power supply and should never be used as such. Severe property damage and/or severe personal injury or death may result. Never connect this generator to an automatic transfer switch (ATS). Severe damage to the generator will occur.



- To avoid accidents or equipment damage, always make a pre-operation inspection before you start the engine.
- Place the generator at least 3 ft (1 m) away from buildings or other equipment during operation.
- Operate the generator on a level surface. If the generator is tilted, fuel spillage may result.
- Know how to stop the generator quickly and understand operation of all controls. Never permit anyone to operate the generator without proper instructions.
- Keep children and pets away from the generator when it is in operation.
- Keep away from moving parts while the generator is running.
- Generators are a potential source of electrical shocks when misused; do not operate with wet hands.
- Do not operate the generator in rain or snow and do not let it get wet.
- Do not operate this generator inside a compartment. Doing so may lead to overheating and consequently, fire. It may also lead to death by asphyxiation.
- Do not modify the enclosure of this generator.

2. COMPONENT IDENTIFICATION

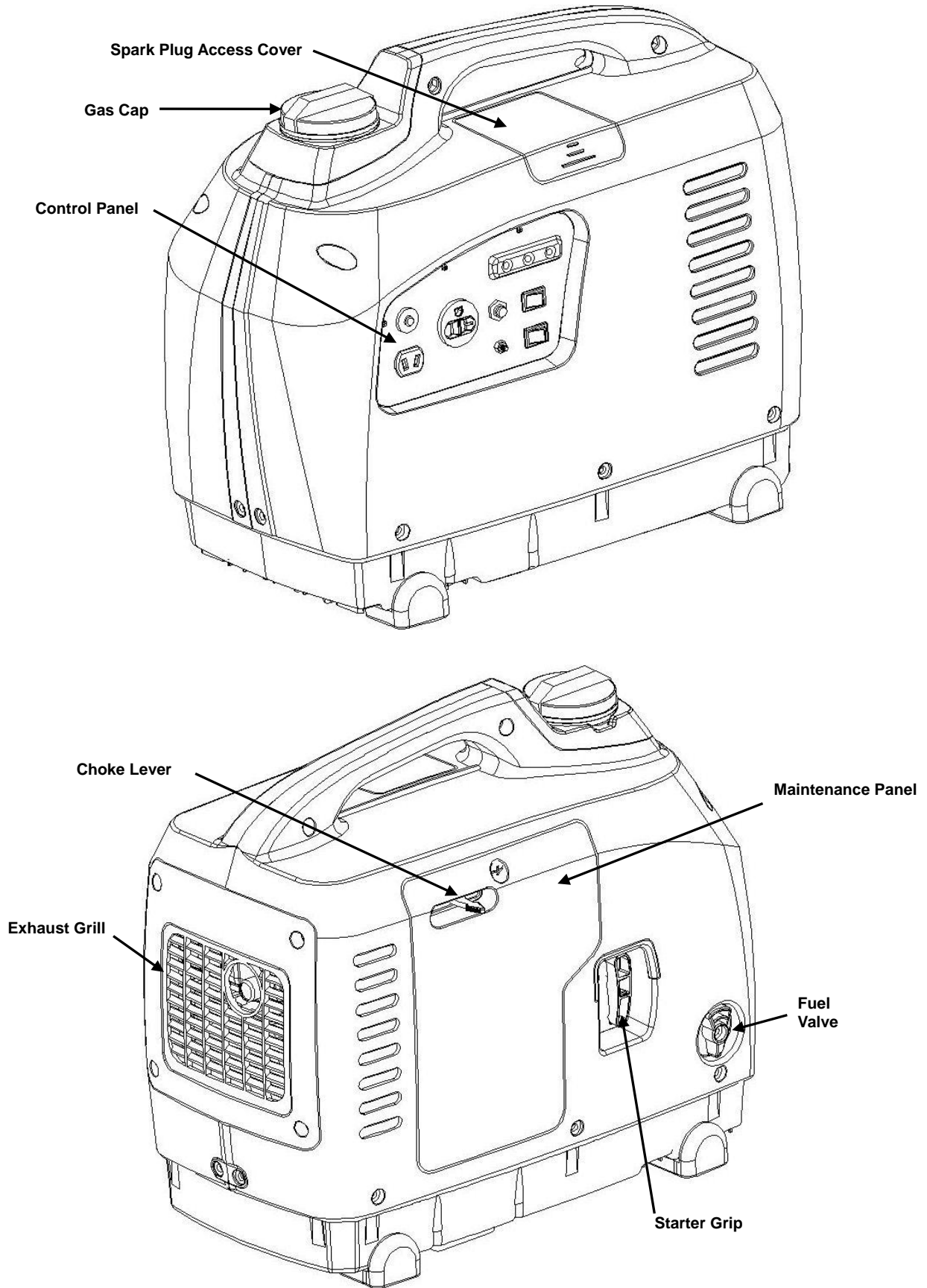

2.1 Control panel 1000Wi

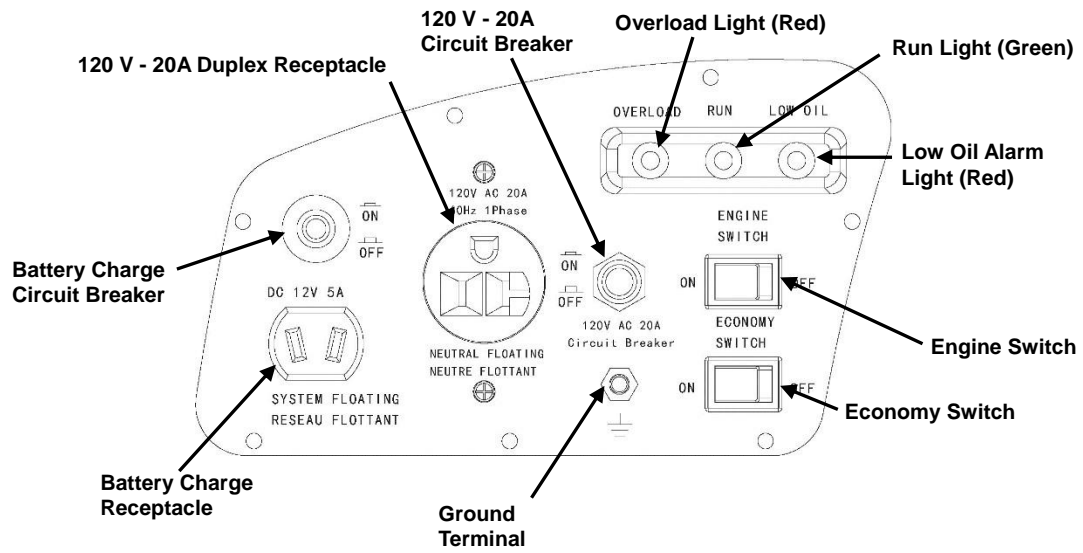

2.2 Serial number and bar code identification and location

The generator bar code number and the engine serial number identify your particular unit and are necessary when ordering parts and accessories. These two numbers are used by your dealer and The Coast Distribution System, Inc. for warranty administration and must be supplied before any work can be done.

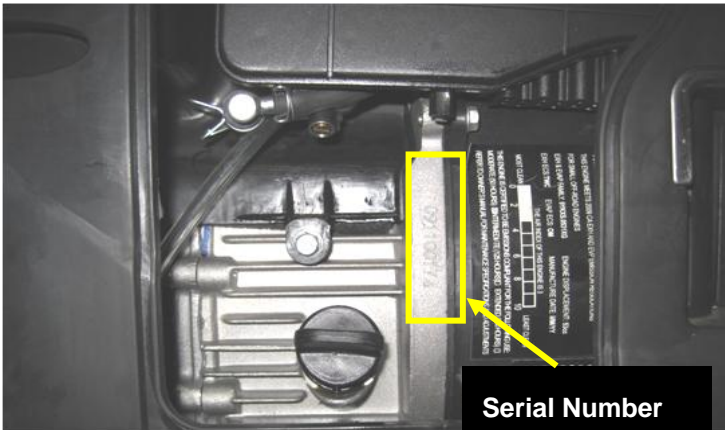

The engine serial number can be found stamped on the engine block above oil dipstick. It is visible when the maintenance panel is removed.

BCN # 100122377055322

The bar code number label is found in three locations:

1. On the side of the generator near the fuel valve.
2. On the back of this manual.

You can also find the BCN number on the foil label on the shipping carton.

Please record this information below and keep this manual in a safe place along with the bill of sale.

Engine Serial Number _____

Bar Code Number _____

Date of Purchase _____

Name of Selling Dealership _____

Please go to **www.powerhouse-products.com/register** and register your unit today. Online registration will be accepted as proof of purchase. Online registration will make sure you are protected in the event you have lost your receipt, and will significantly speed the process in the event warranty service is necessary.

For warranty assistance:

Phone: 877-544-4449

Fax: 800-263-0280

E-mail: **warranty@powerhouse-products.com**

3. PRE-OPERATION CHECK



WARNING

- Be sure to check the generator on a level surface with the engine stopped.

3.1 Check the engine oil level



CAUTION

- Do not use non-detergent oil or 2-stroke engine oil. It will void the warranty and will shorten the engine's service life.
- Use a high-detergent, premium quality, 4-stroke engine oil, certified to meet or exceed U.S. automobile manufacturer's requirements for API Service Classification SG/SF. Synthetic oil is approved for use in Powerhouse generators, and is recommended for operating the generator in temperatures below 32° F.
- Change the oil in a new engine between the first 4 to 6 hours of operation to clean manufacturing debris and contamination.
- Use SAE 15W-40 viscosity oil unless operating at ambient temperatures below 32° F (0° C). For temperatures below 32° F, use SAE 0W-40 viscosity oil. Refer to the [Operating at extreme temperatures](#) section for more information.

1. Loosen the cover screws and remove the maintenance cover.
2. Remove the dipstick, wipe it with a clean rag and reinsert it into the filler neck, screwing it down completely.
3. Remove the dipstick again and check the oil level.
4. If the oil level is at or below the lower level of the dipstick, refill with the recommended oil up to the top of the upper level marking. Do not overfill.
5. Reinsert the dipstick and be sure to screw it down until it is tight.



WARNING

- Running the engine with insufficient oil can cause serious engine damage.
- The Low Oil Alarm System will automatically stop the engine before the oil level falls below a safe limit. However, to avoid the inconvenience of an unexpected shutdown, it is still advisable to visually inspect the oil level regularly.

Engine oil capacity: 8.5 fl oz (0.53 pt) / 250 ml

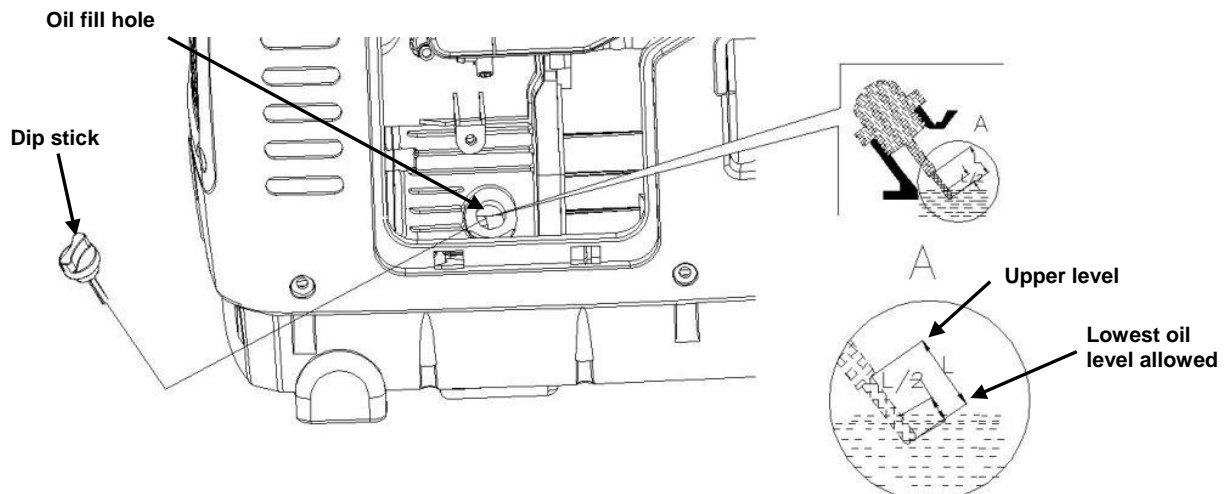

3.2 Check the fuel level

Use automotive unleaded regular gasoline only.

1. If the fuel level is low, refill to the top of the fuel strainer.
2. Never use an oil/gasoline mixture or dirty gasoline.
3. Avoid getting dirt, dust or water in the fuel tank.
4. After refueling, tighten the fuel filler cap securely.

NOTE

- It is recommended that you use a fuel stabilizer, such as STA-BIL®, to help prevent fuel oxidation (breakdown) and the formation of gum and varnish, and to inhibit corrosion in the fuel system and carburetor.

WARNING

- Gasoline is extremely flammable and is explosive under certain conditions.
- Refuel in a well-ventilated area with the engine stopped. Keep all smoking materials, sparks, and any other source of combustion away from the generator during refueling.
- Do not overfill the fuel tank (there should be no fuel above the top of the fuel strainer). After refueling, make sure the tank cap is closed properly and securely.
- Be careful not to spill fuel when refueling. Spilled fuel or fuel vapor may ignite. If any fuel is spilled, make sure the area is dry before starting the engine.
- Avoid repeated or prolonged contact with skin or breathing of vapor. **KEEP OUT OF REACH OF CHILDREN.**

Fuel tank capacity: 0.78 gal (2.95 Liters)

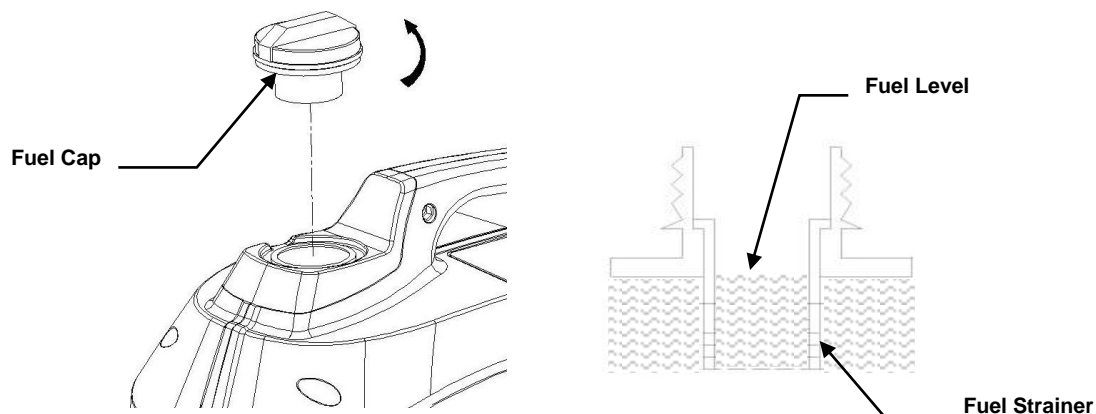

Gasoline containing alternate fuels

Do not use a blend that contains more than 10% ethanol. Do not use gasoline containing methanol. An octane rating of 87 or higher is recommended.

NOTE

- Fuel system damage or engine performance problems resulting from the use of fuels that contain an improper alcohol blend, or by adding oil to the fuel, are *not* covered under warranty.
- Before buying fuel from an unfamiliar station, determine if the fuel contains ethanol and if it does, confirm the type and percentage of ethanol used. If you notice any undesirable operating symptoms while using a gasoline that contains ethanol, or one that you think contains ethanol, replace it with a gasoline that you know has the proper blend.

3.3 Check the air cleaner

1. Loosen the maintenance cover screw and remove the maintenance cover.
2. Remove the air filter retaining screw. Remove the cover and check the element. Clean or replace the element if necessary.
3. Replace the air cleaner element, and cover. Tighten the screw securely.
4. Replace the maintenance cover and tighten the screw securely.



- Never run the engine without the air cleaner element in place. Rapid engine wear will result from contaminants, such as dust and dirt being drawn through the carburetor into the engine.

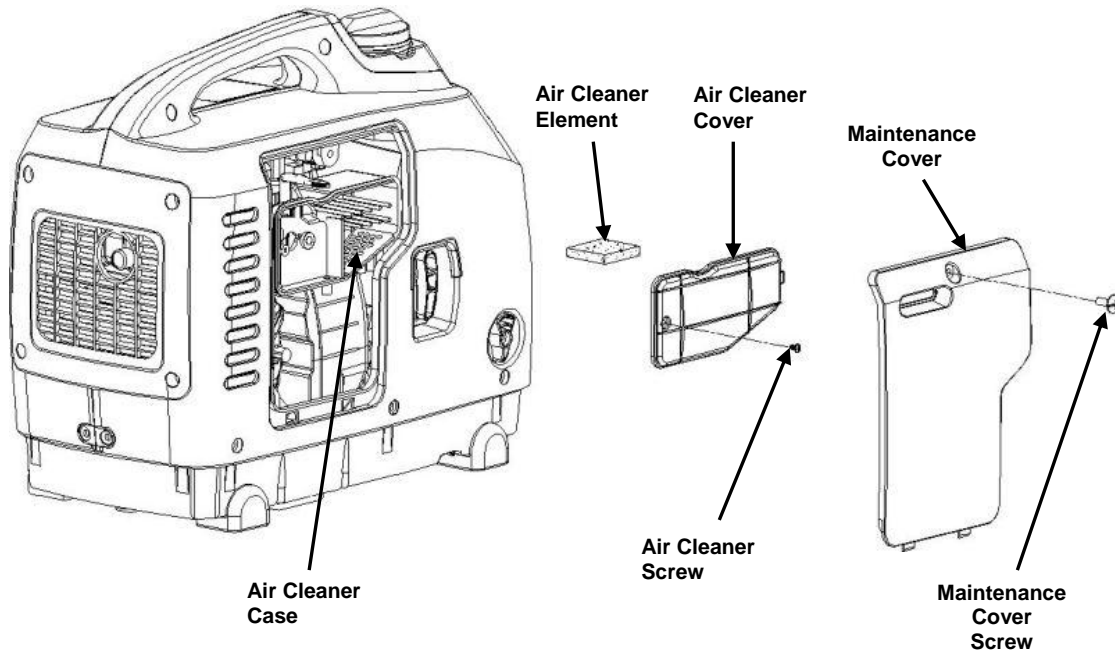

4. OPERATING INSTRUCTIONS

4.1 Starting the engine

NOTE

- When starting the generator after adding fuel for the first time or after long term storage, or after running out of fuel, turn the fuel valve to the ON position, then wait for 10 to 20 seconds before starting the engine.
- Before starting the engine, disconnect any load from the AC receptacles.

1. Turn the fuel valve to the ON position.
2. Push the engine switch on the control panel to the ON position.
3. Move the choke lever to the START position.
4. Pull the starter grip lightly until resistance is felt, then pull briskly out.
5. Move the choke lever to the RUN position after the engine warms up.

CAUTION

- Do not allow the starter grip to snap back. Return it slowly by hand.
- Do not let the starter rope rub against the generator body or the rope will wear out prematurely.

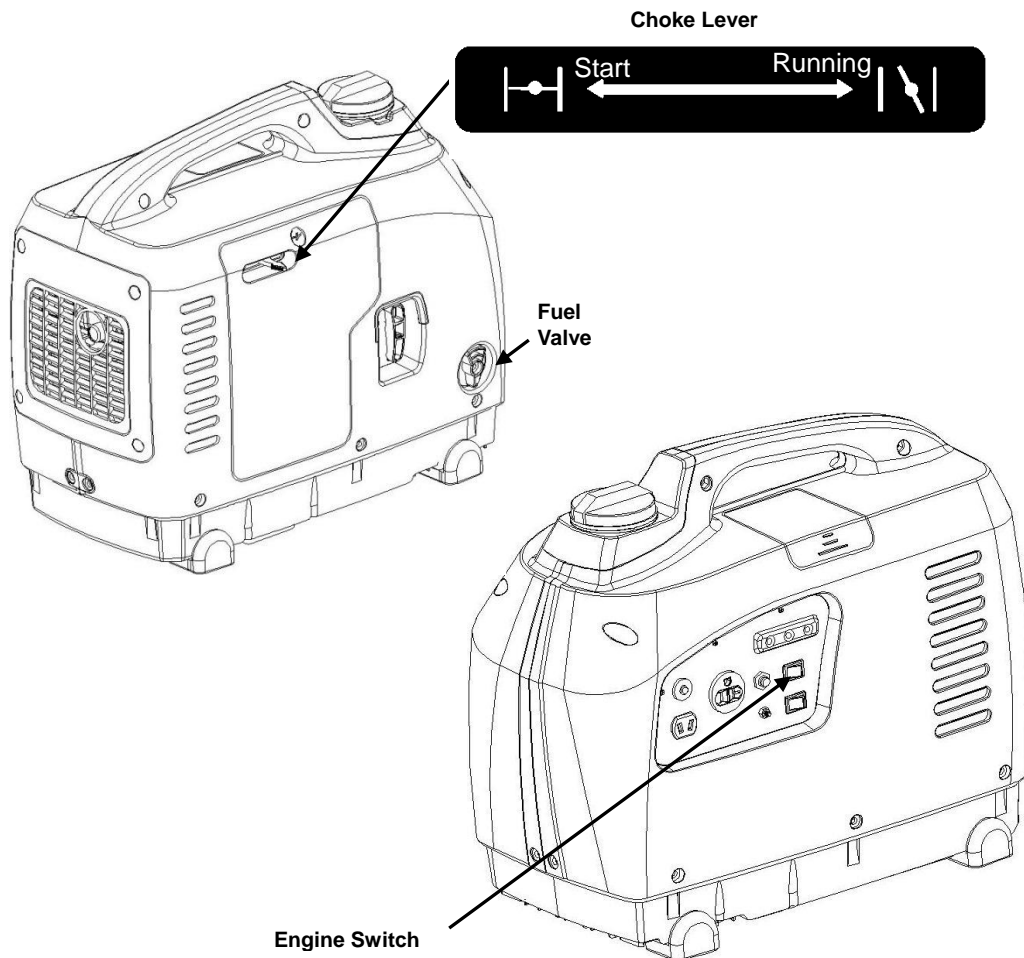

4.2 High altitude operation

At higher altitudes, the standard carburetor air-fuel mixture will be excessively rich. Performance will decrease, and fuel consumption will increase. Engine horsepower will decrease approximately 3.5% for each 1000 feet (305 m) increase in altitude.

4.3 Operating at extreme temperatures

High temperature adversely affects generator operation. Generator performance will decrease 1% for each 10°F (5.5°C) increase in temperature above 85°F (29°C). The normal operating range of this generator is 0° to 113° F (-18° to 45°C). Although the generator can operate at 0° F (-18° C) it will be necessary to use a lower viscosity engine oil such as SAE 0W-40. Synthetic oil is recommended for temperatures below 32° F. Even with cold weather oils, the engine will be more difficult to start.

NOTE

- In very cold weather the engine will actually take longer than normal to warm up because the oil is thinner and there is less internal friction throughout the warm up period. Once the engine reaches operating temperature 0W-40 oil is no thinner than straight 40W.

WARNING

- Do not operate the generator when the ambient temperature is below 0°F (-18°C).
- Do not operate the generator when the ambient temperature exceeds 113°F (45°C).

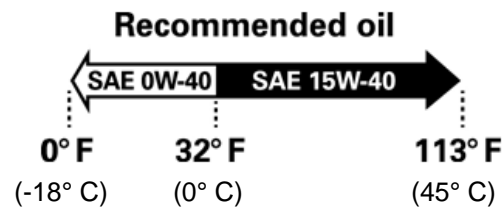

4.4 Generator use

Be sure to ground the generator when loads are connected.

WARNING

- To prevent electrical shock from faulty appliances, the generator should be grounded. Connect a length of heavy cable between the generator's ground terminal and an external ground source.
- Connections for standby power to a building's electrical system must be made by a qualified electrician and must comply with all applicable laws and electrical codes. Improper connections can allow electrical current from the generator to back feed into the utility lines. Such back feed may electrocute utility company workers or others who contact the lines during a power outage. When utility power is restored, the generator may explode, burn, or cause fires in the building's electrical system.
- Do not connect the generator to an automatic transfer device. Severe damage to the inverter module may result.
- Indoor use of a generator can kill quickly. Generators should be used outdoors only.

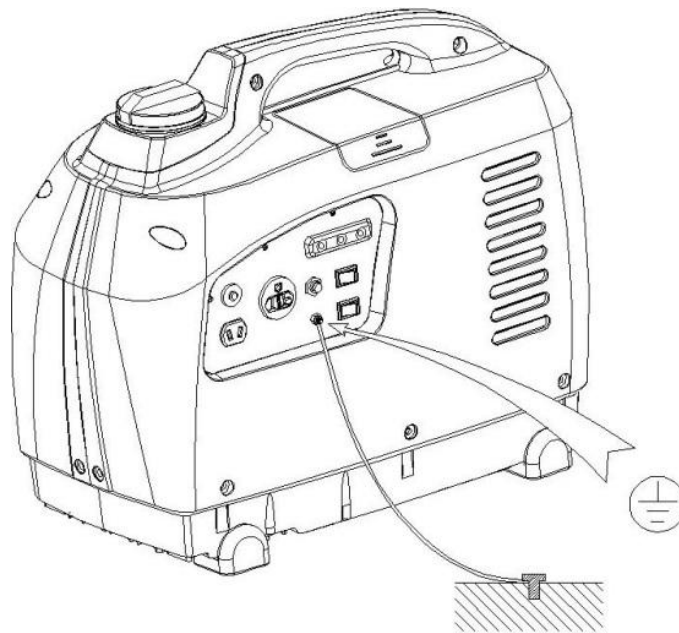

CAUTION

- The total wattage of all appliances connected must be considered.
- Do not exceed the current limit specified for any one receptacle.
- Do not connect the generator to a household circuit. This could cause damage to the generator or to electrical appliances in the house.
- Do not modify this generator or use it for purposes other than its intended use.
- Do not connect an extension to the exhaust pipe.
- When an extension cord is required, be sure to use a rubber sheathed flexible cord. Also make sure to use the proper size and length cord.
 - 16 Gauge Cords - a 16 gauge cord between 0 and 100 feet long will safely handle tool and appliance loads up to 10 amps.
 - 14 Gauge Cords - a 14 gauge cord between 0 and 50 feet long will safely handle tool and appliance loads between 10 and 15 amps.
 - 12 Gauge Cords – a 12 gauge cord between 50 and 100 feet will safely handle tool and appliance loads between 10 and 15 amps.
- Keep the generator away from other electric cables or wires such as commercial power supply lines.

NOTE

- The DC receptacle can be used while the AC power is in use. If you use both at the same time, be sure not to exceed the total power for AC and DC.
- Most appliance motors require more than their rated wattage for start-up.

4.5 AC application

1. Start the engine and make sure only the output run indicator light (Green) comes on.
2. Confirm that the appliance to be used is switched off before plugging into the control panel.

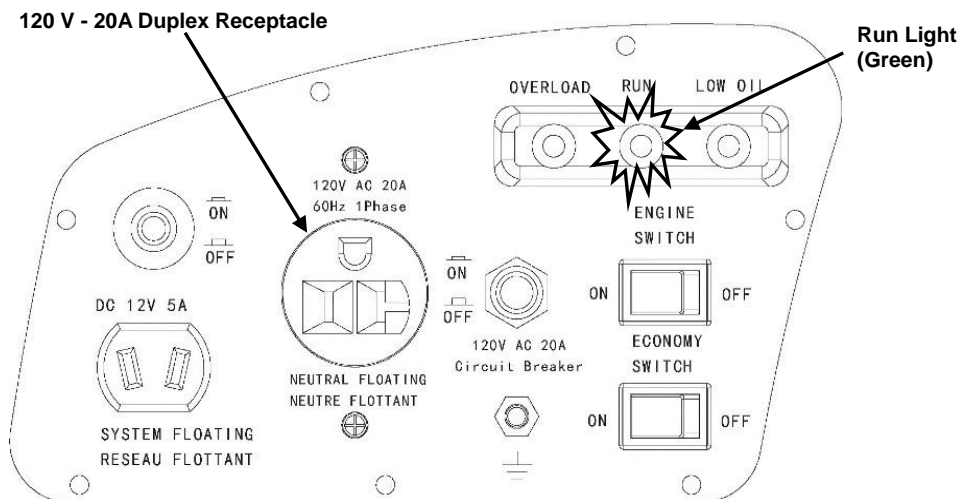

CAUTION

- Be sure that all appliances are in good working order before connecting them to the generator. If an appliance begins to operate abnormally, becomes sluggish, or stops suddenly, turn off the generator engine switch immediately. Disconnect the appliance and examine it for signs of malfunction.

4.6 Output and Overload Lights

CAUTION

- Substantial overloading that continuously lights the overload light (Red) may damage the generator. Marginal overloading that temporarily lights the overload light (Red) may shorten the service life of the generator.

The output indicator light (Green) will remain illuminated during normal operating conditions.

If the generator is overloaded (in excess of 1000 W), or if there is a short in the connected appliance, the output indicator light (Green) will go out, the overload indicator light (Red) will turn on and current to the connected appliance will be shut off.

1. Remove all electrical loads from the generator and investigate the cause of the overload.
2. To reset the overload condition (Red light), stop and restart the generator. The (Green) indicator light should be illuminated within 10 seconds.

NOTE

- Before connecting or reconnecting an appliance to the generator, check that it is in good order, and that its electrical rating does not exceed that of the generator.
- When an electric motor is started, the overload indicator light (Red) may go on momentarily while the output indicator light (Green) remains on. This is not a problem as long as the overload light only flickers on briefly.

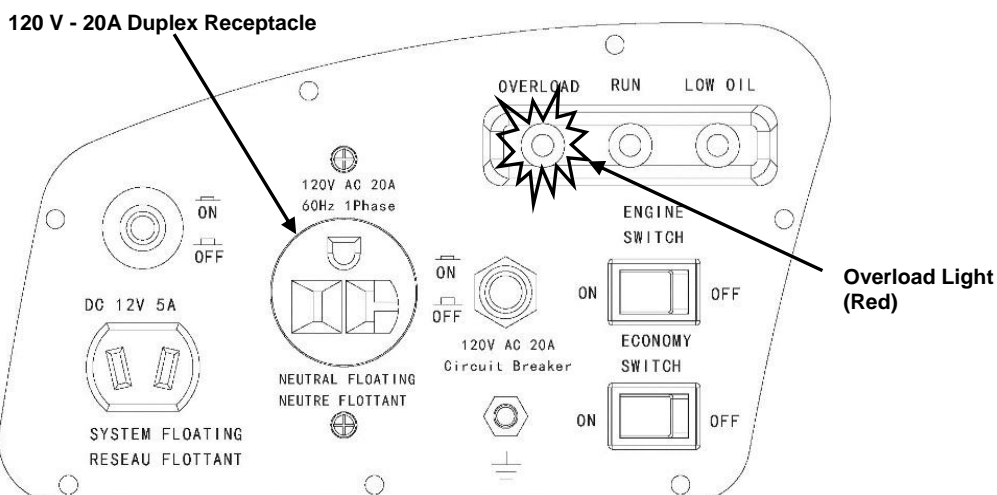

4.7 DC application

WARNING

- The DC receptacle may be used for charging 12 volt lead acid batteries only. Other types of batteries may burst causing personal injury or damage.
- To prevent the possibility of creating a spark near the battery, connect the charging cable first to the battery being charged, and then to the generator. When charging is complete, disconnect the cable first at the generator.
- Before connecting charging cables to a battery that is installed in a vehicle, disconnect the vehicle's ground battery cable. Reconnect the vehicle's ground battery cable after the charging cables are removed. This procedure will prevent the possibility of a short circuit and sparks if you make accidental contact between a battery terminal and the vehicle's frame or body.
- Connect the positive charging cord to the positive battery terminal. Do not reverse the charging cables, or serious damage to the generator and/or battery may occur. Physical injury may also occur.

CAUTION

- Do not attempt to start an automobile engine with the generator still connected to the battery. The generator may be damaged.
- Connect the positive charging cord to the positive battery terminal. Do not reverse the charging cables, or serious damage to the generator and/or battery may occur.
- DC operation is only intended for the purpose of charging batteries. It should not be used to power DC equipment.

1. For DC operation, with the engine running, turn the economy switch to the "OFF" position.
2. Connect the charging cables to the battery terminals first.
3. Connect the charging cables to the DC receptacle of the generator last.

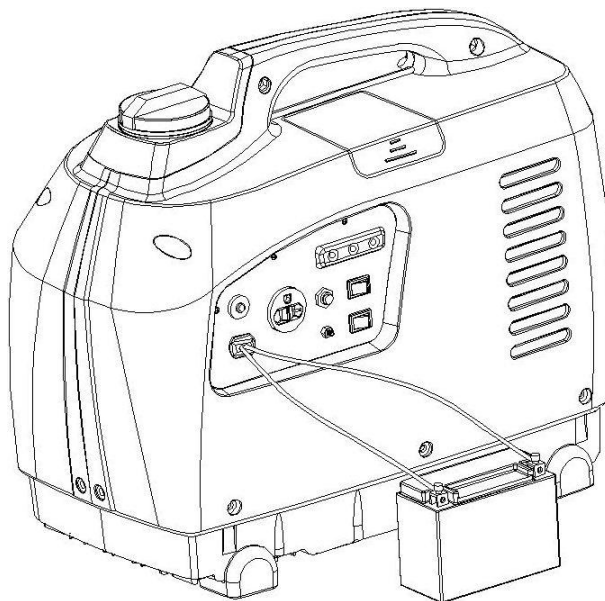

WARNING

- Batteries give off explosive gases; keep spark, flames and cigarettes away. Provide adequate ventilation when charging.
- Batteries contain sulfuric acid (electrolyte). Contact with skin or eyes may cause severe burns. Wear protective clothing and a face shield.
 - If electrolyte gets on your skin, flush with water.
 - If electrolyte gets in your eyes, flush with water for at least 15 minutes and call a physician immediately.
- Electrolyte is poisonous.
 - -If swallowed, drink large quantities of water or milk and follow with milk of magnesia or vegetable oil and call a physician immediately.
- KEEP OUT OF REACH OF CHILDREN.

NOTE

- The DC receptacle may be used while the AC power is in use.
- An overloaded DC circuit will trip the DC circuit breaker. If this happens reset the circuit breaker to resume operation.

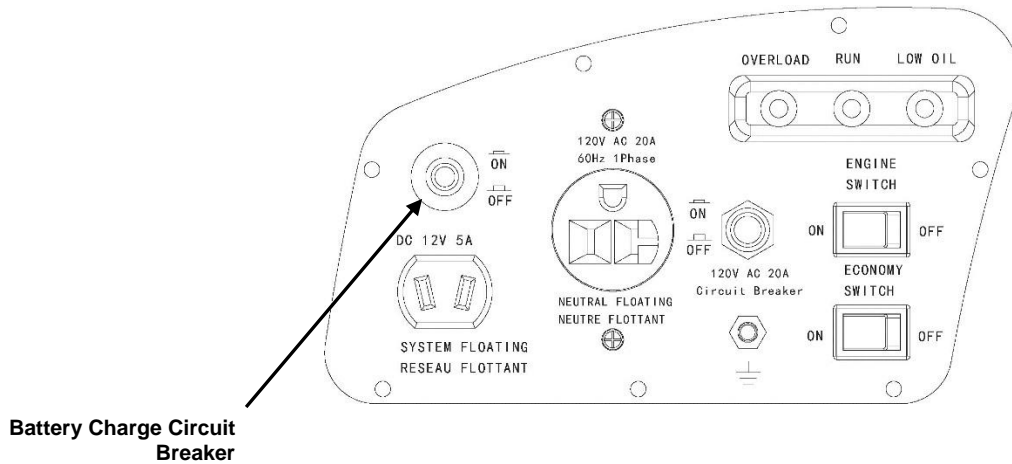

4.8 Low oil alarm system

The low oil alarm system is designed to prevent engine damage caused by an insufficient amount of oil in the crankcase. Before the oil level in the crankcase falls below a safe limit, the low oil alarm system will automatically shut down the engine (the engine switch will remain in the "ON" position).

If the low oil alarm system shuts down the engine, the low oil alarm indicator light (Red) will come on when you pull the starter rope and the engine will not run. If this occurs add enough of the approved engine oil to raise the level to the top line on the dipstick.

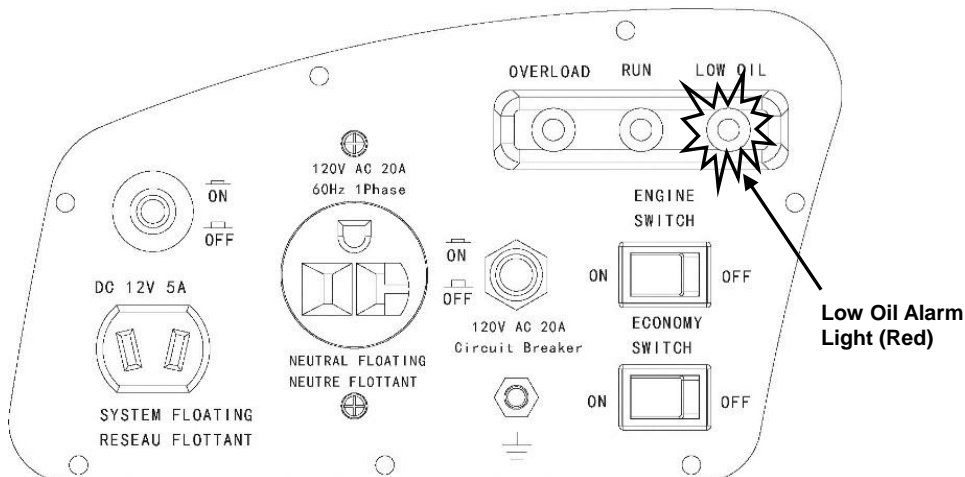

4.9 Economy switch

Economy switch “ON”: This position is recommended to minimize fuel consumption and noise while in operation. Engine speed is kept at idle automatically when the electrical load is disconnected and returns to the proper speed to match the power of the electrical load when the load is reconnected.

NOTE

- The economy system does not operate effectively if the electrical appliance requires rapid on-off cycling of power.
- When high electrical loads are connected simultaneously, turn the economy switch to the “OFF” position to reduce voltage fluctuation or shutdown.
- In DC operation, turn the economy switch to the “OFF” position.

Economy switch “OFF”: The economy system does not operate. Engine runs at the rated load (RPM).

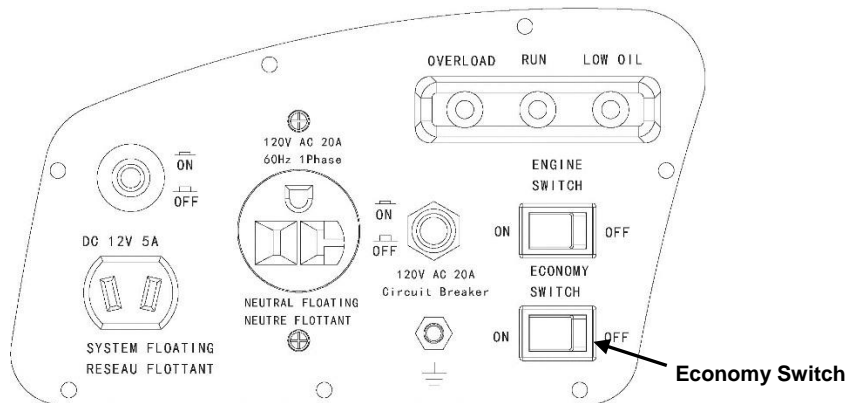

4.10 Stopping the engine

To stop the engine in an emergency

1. Push the engine switch on the control panel to the “OFF” position.

NOTE

- In an emergency, pushing the engine switch on the control panel to the “OFF” position will automatically stop the engine with or without a load. However, repeatedly stopping the generator without disconnecting all loads can cause damage to the generator or appliances.

Normal shutdown

1. Turn off the connected equipment and disconnect from the generator.
2. Push the engine switch to the “OFF” position.
3. Turn the fuel valve to the “OFF” position.

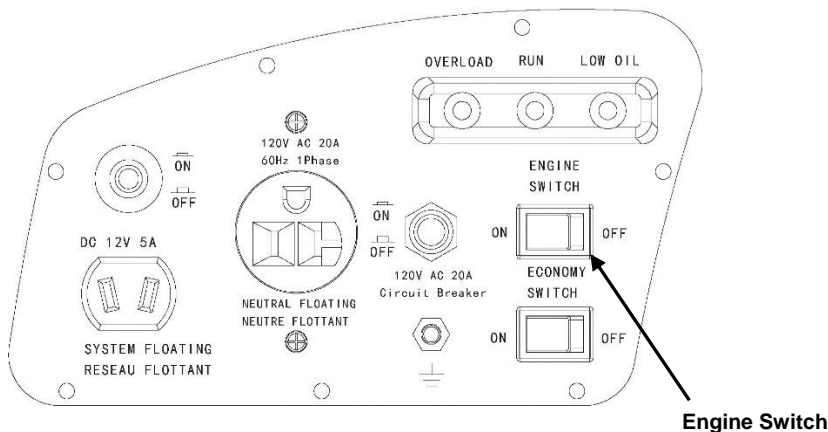

5. MAINTENANCE

The purpose of the maintenance and adjustment schedule is to keep the generator in the best possible operating condition.

Inspect or service as scheduled in the table below.

There are no special operating instructions for the break in period for the engine, but the oil should be changed between the first 4 to 6 hours of operation to remove any manufacturing debris or contamination.



- Shut off the engine before performing any maintenance. If the engine must be run, make sure the area is well ventilated. The exhaust contains poisonous carbon monoxide gas.



- Use genuine POWERHOUSE® parts or their equivalent. The use of replacement parts which are not of equivalent quality may damage the generator.
- When repairing or replacing components of the emission control system, only use parts known to comply with EPA standards.

5.1 Emission control system

Emission source

Exhaust gas contains carbon monoxide, nitrogen oxides (NO_x), and hydrocarbons. It is very important to control the emissions of NO_x and hydrocarbons as they are a major contributor to air pollution. Carbon monoxide is a poisonous gas. The emission of fuel vapors is a source of pollution as well. The POWERHOUSE® generator engine utilizes a precise air-fuel ratio and emission control system to reduce the emissions of carbon monoxide, NO_x, hydrocarbons, and evaporative fuel emissions.

Regulation

Your engine has been designed to meet current Environmental Protection Agency (EPA) and the California Air Resources Board (CARB) clean air standards. The regulations dictate that the manufacturer provides operation and maintenance standards regarding the emission control system. Tune up specifications are provided in the Specifications section and a description of the emission control system may be found in the appendix to this manual. Adherence to the following instructions will ensure your engine meets the emission control standards.

Modification

Modification of the emission control system may lead to increased emissions. Modification is defined as the following:

- Disassembling or modifying the function or parts of the intake, fuel, or exhaust system.
- Modifying or destroying the speed governing function of the generator.

Engine faults that may affect emission

Any of the following faults must be repaired immediately. Consult with your authorized POWERHOUSE® service center for diagnosis and repair:

- Hard starting or shut down after starting.
- Unstable idle speed.
- Shut down or backfire after applying an electrical load.
- Backfire.
- Black smoke and/or excessive fuel consumption.

Replacement parts and accessories

The parts making up the emission control system supplied with the POWERHOUSE® engine have been specifically approved and certified by the regulatory agencies. You can trust that replacement parts supplied by POWERHOUSE® have been manufactured to the same production standard as the original parts. The use of replacement parts or accessories which are not designed by POWERHOUSE® may affect the engine emission performance. The manufacturers of replacement parts and accessories have the responsibility to guarantee that their replacement products will not adversely affect emission performance.

Maintenance

Maintain the generator according to the maintenance schedule in this section. Service items more frequently when used in dusty areas, or under conditions of high load, temperature, and humidity.

Air Quality Index (only for California certified models)

CARB requires that an air quality index label be attached to every certified engine showing the engine emission information for the emission duration period. The label is provided for the user to compare the emission performance of different engines. The lower the air index, the better the engine emission performance. The description of durability is helpful for the user to learn the engine emission duration period and the service life of emission control system. Refer to the warranty section of this Owner's Manual for more information.

The air quality index label is designed to be permanently affixed to the generator and removal should not be attempted.



(Sample image)

5.2 Maintenance Schedule

Item	Maintenance Procedure	Regular Service period (1). Perform at every indicated month or operating hour interval, whichever occurs first.				
		Each Use	1 st Month or 4 to 6 Hours	Every 3 Months or 50 Hours	Every 6 Months or 100 Hours	1x per Year Or 300 Hours
Engine Oil	Check	0				
	Change		0		0	
Air cleaner	Check	0				
	Clean			0 (2)		
Spark Plug	Clean / Adjust				0	
Spark Arrester	Clean				0	
Fuel Filter	Check	0				
	Replace					0 (2)
Valve clearance	Check / Adjust					0 (3)
Fuel tank & strainer	Clean					0 (2)
Fuel line	Check	Every 2-years (Replace as necessary) (3)				



- (1) Log hours of operation to determine proper maintenance.
 (2) Service more frequently when used in dusty areas.
 (3) These items should be serviced by an authorized dealer unless the owner has the proper tools and is mechanically proficient. See the Service Manual.

Service Period for Oil Changes	Temperature
Normal –100 hr	77°F (25°C)
95 hr	86°F (30°C)
85 hr	95°F (35°C)
70 hr	104°F (40°C)

5.3 Changing oil

Drain the oil while the engine is still warm to assure rapid and complete draining.

CAUTION

- Make sure to turn the engine switch "OFF" before draining the oil.

1. Loosen the cover screw and remove the side maintenance cover.
2. Remove the oil dipstick.
3. Install the oil drain pipe (included with the generator).
4. Drain the dirty oil into a container. Be sure to allow time for the oil to drain completely.
5. Refill with the recommended oil, and check to be sure the oil level is at the upper line on the dipstick.
6. Reinstall the dipstick and then the maintenance cover and tighten the screw securely.

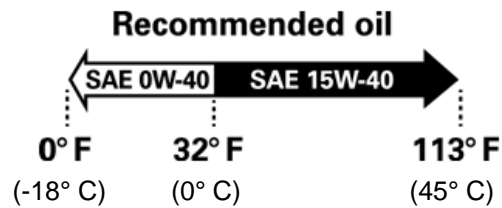

Recommended oil is SAE 15W-40 when ambient temperature is above 32° F (0° C).

SAE 0W-40 is recommended if operating temperatures are below 32° F (0° C).

Synthetic oil is approved for use in POWERHOUSE® generators, and is recommended for operating the generator in temperatures below 32° F.

Engine oil capacity: 8.5 fl oz (250 ml)

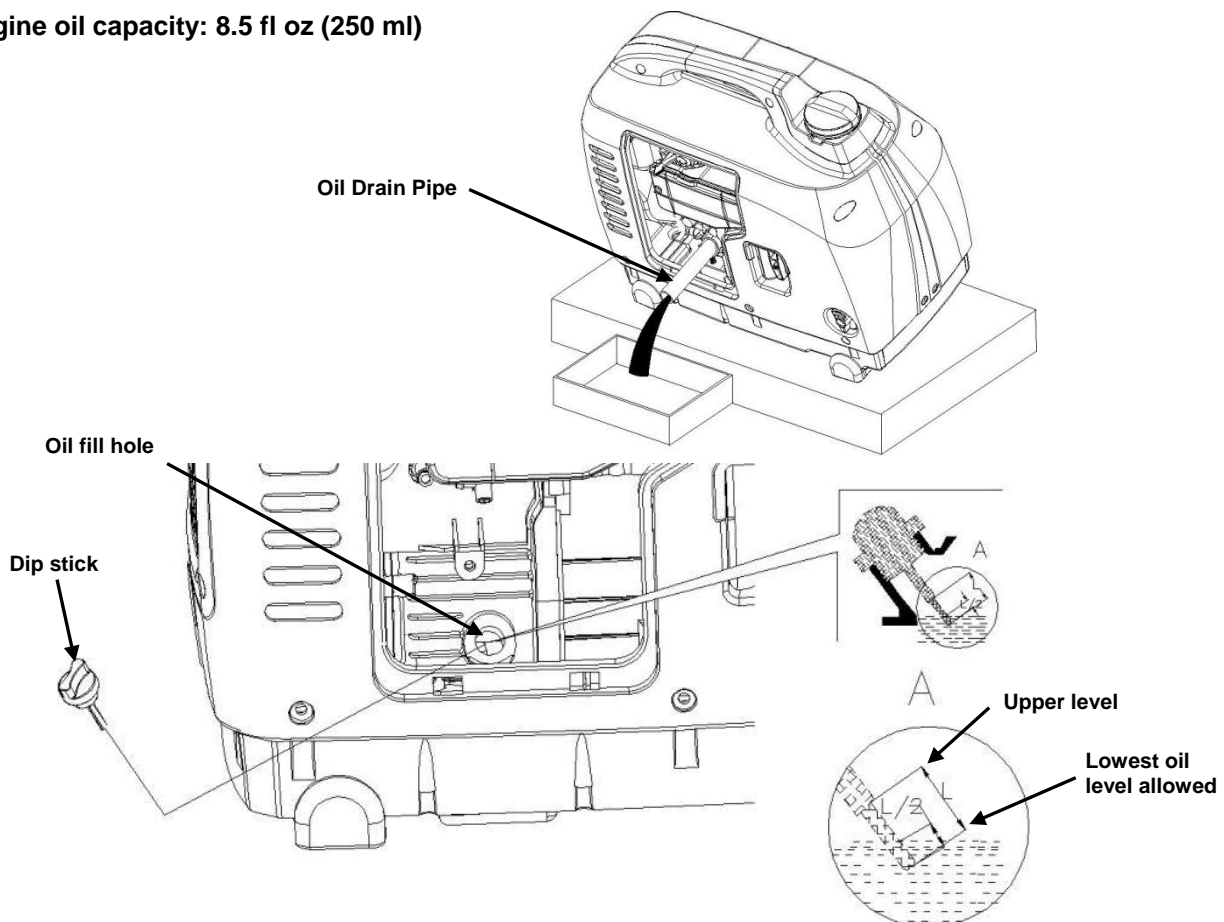

NOTE

- Please dispose of used motor oil in a manner that is compatible with the environment and local disposal regulations. Do not throw it in the trash or pour it on the ground.

5.4 Air cleaner service

A dirty air cleaner will restrict air flow to the carburetor. To prevent carburetor malfunction, service the air cleaner regularly. Service more frequently when operating the generator in extremely dirty areas.



- Do not use gasoline or low flash point solvents for cleaning. They are flammable and explosive under certain conditions.



- Never run the generator without the air cleaner, otherwise rapid engine wear may result.

1. Loosen the panel screw and remove the side maintenance panel.
2. Remove the air filter retaining screw. Remove the air cleaner cover and check the air cleaner element. Clean or replace the element if necessary.
3. Wash the element in a non-flammable or low flash point solvent and dry it thoroughly.
4. Soak the element in clean engine oil and squeeze out the excess oil.
5. Reinstall the air cleaner element and the air cleaner cover. Tighten the cover screw securely.
6. Reinstall the maintenance cover and tighten the screw securely.

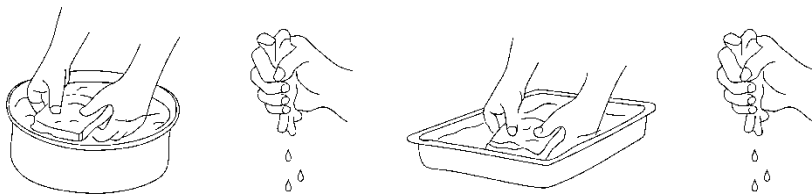
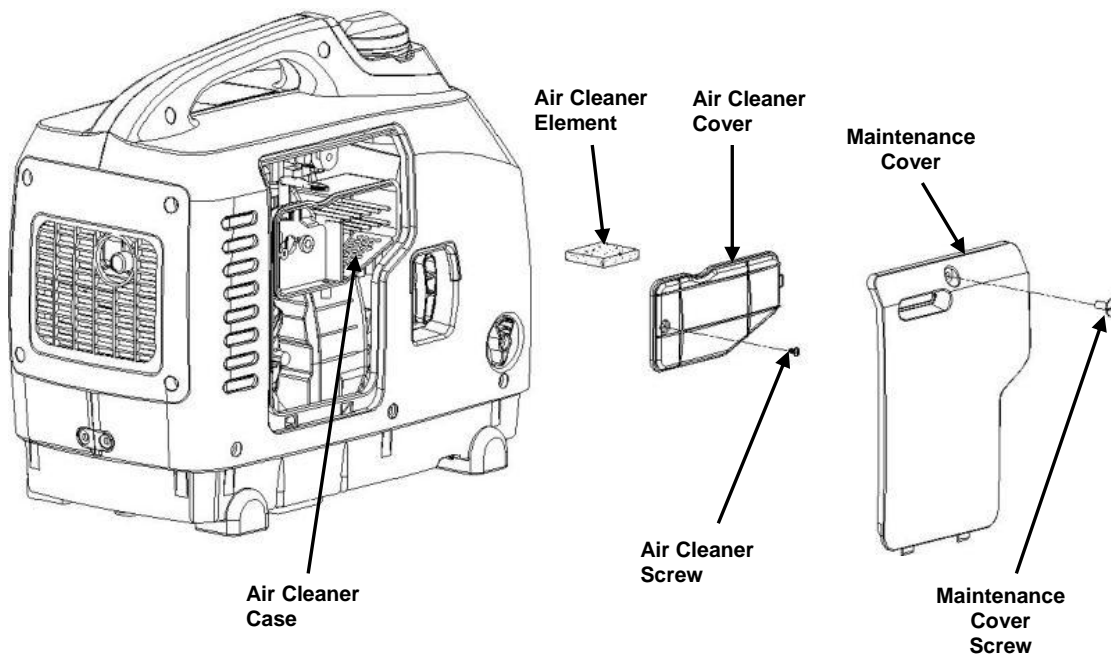

5.5 Spark plug maintenance

RECOMMENDED SPARK PLUG: A7RTC

To ensure proper engine operation, the spark plug must be properly gapped and free of deposits.

1. Loosen the cover screw and remove the spark plug maintenance cover.
2. Remove the spark plug cap.
3. Clean any dirt from around the spark plug base.
4. Use the supplied wrench to remove the spark plug.
5. Visually inspect the spark plug. Discard it if the insulator is cracked or chipped.
6. Clean the spark plug with a wire brush if it is to be reused.
7. Measure the plug gap with a feeler gauge.
8. The gap should be 0.024-0.028in (0.6-0.7mm). Correct as necessary by carefully bending the side electrode.

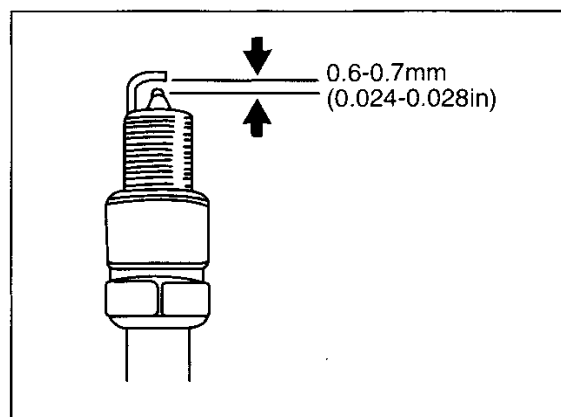
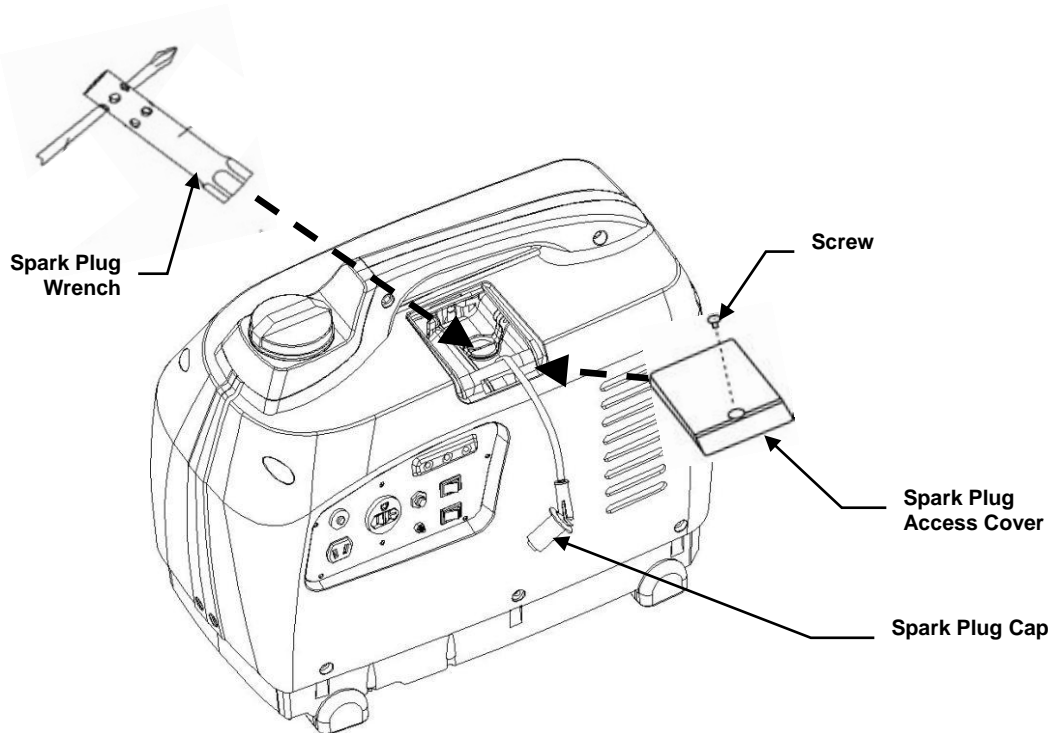

9. Install the spark plug carefully, by hand, to avoid cross-threading.
10. After a new spark plug has been seated by hand, it should be tightened 1/2 turn with a wrench to compress its gasket. If a used plug is being reinstalled, it should only require 1/8 to 1/4 turn after being seated.
11. Reinstall the spark plug cap on the spark plug securely.
12. Reinstall the spark plug maintenance cover.

CAUTION

- The spark plug must be securely tightened. An improperly tightened plug can become very hot and possibly damage the generator.
- Never use a spark plug with an improper heat range.
- Always use an A7RTC resistor-type spark plug. Using a non-resistor spark plug will interfere with AC output and the electronics, and may prevent the engine from starting.

5.6 Spark arrestor maintenance

CAUTION

- If the generator has been running, the muffler will be very hot. Allow it to cool before proceeding.

NOTE

- The spark arrestor must be serviced every 100 hours to maintain its efficiency, or a decrease in horsepower may occur.
- Because of the size of the spark arrestor opening in the exhaust grill you may decide that you do not want to take off the grill. This will not cause an issue unless you drop the arrester or the clamp or screws behind the grill. Taking the grill off or leaving it on is a matter of your convenience, but the procedure below will include removing the grill.

1. Remove the four M6 screws and remove the muffler grill.
2. Remove the two M4 screws holding the spark arrester to the muffler.
3. Use a stiff wire brush to remove carbon deposits from the spark arrestor screen.
4. Inspect the screen for holes, and replace it if necessary.
5. Reinstall the spark arrester.
6. Reinstall the muffler grill.

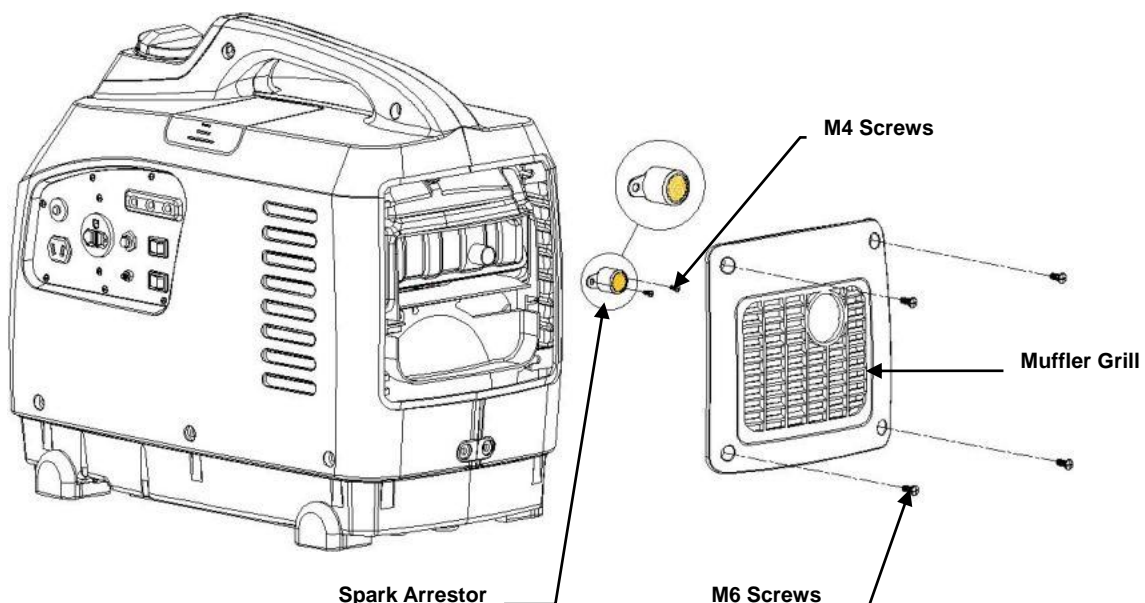

6. TRANSPORTING and STORAGE

6.1 Transporting the generator

When transporting the generator, it should always be secured upright in its normal operating position with the fuel valve and engine switch turned "OFF".

When transporting the generator:



- Do not operate the generator while it is on or in a vehicle.
- If you must transport the generator in an enclosed vehicle, drain all fuel from the generator.

6.2 Short term storage of the Generator

During short term storage, the generator should be secured upright in its normal operating position with the fuel valve and engine switch turned "OFF".

Avoid placing the generator in direct sunlight when storing.

If the generator is left in an enclosed area or vehicle, high temperatures inside could cause residual fuel to vaporize resulting in possible explosion.

6.3 Infrequent use

WARNING

- Gasoline is extremely flammable and explosive under certain conditions.
- Do not smoke or allow flames or sparks in the area.

NOTE

- During long-term storage, or infrequent use of your equipment, it is important to add a fuel stabilizer, such as STA-BIL® Fuel Stabilizer, to help prevent fuel oxidation (breakdown) and the formation of gum and varnish, and to inhibit corrosion in the fuel system and carburetor.

1. Be sure the storage area is free of excessive humidity and dust.
2. It is best to keep the tank at least 95% full, as condensation will be less likely to occur in the fuel tank during storage if the tank is full. Do not overfill the tank, as the fuel will need room to expand on hot days. Add an appropriate amount of fuel stabilizer (per the instructions on the bottle) and run the generator for 5 minutes to ensure that any fuel trapped in the system has the stabilizer in it. You may also opt to add the fuel stabilizer and run the unit until it is out of fuel.

If you opt to drain the fuel, then continue on with the instructions below.

3. To drain the gasoline from the fuel tank, turn the engine switch to the “OFF” position.
4. Attach a hose to the drain fitting on the carburetor and place the other end of the hose into an approved gasoline container.
5. Turn the fuel valve to the “ON” position, and loosen the carburetor drain screw and drain the gasoline into the approved gasoline container.
6. After the fuel tank has been drained, with the drain screw loosened, disconnect the spark plug wire and pull the starter grip 3 to 4 times to drain the gasoline from the fuel pump.
7. Turn the fuel valve to the “OFF” position, and tighten the drain screw securely.
8. Change the engine oil.
9. Remove the spark plug and pour about a tablespoon of clean engine oil into the cylinder.
10. Crank the engine several revolutions to distribute the oil and then reinstall the spark plug.
11. Slowly pull the starter grip until resistance is felt. At this point, the piston is coming up on its compression stroke and both the intake and exhaust valves are closed. Storing the engine in this position will help to protect it from internal corrosion.

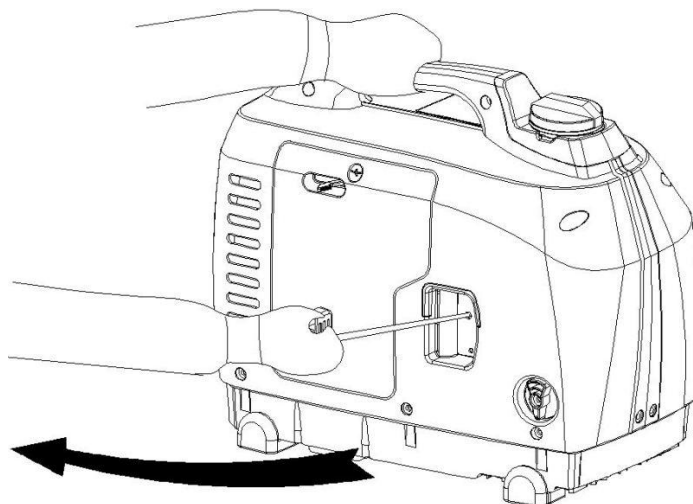

6.4 Exercising the Generator

It is essential that the generator be exercised on a regular basis. This will prevent the accumulation of varnish or sludge in the fuel system; remove moisture from the generator windings. Additionally the engine seals and moving components will be lubricated. Exercise the generator by running it with at least a 1/2 load (450W) for 15 minutes per month. Gasoline fuel treatments (such as STA-BIL®) to prevent contamination of your fuel supply are available from your dealer. Fuel varnishing necessitating replacement of the carburetor is not a warrantable failure.

7. TROUBLESHOOTING

7.1 Engine will not start

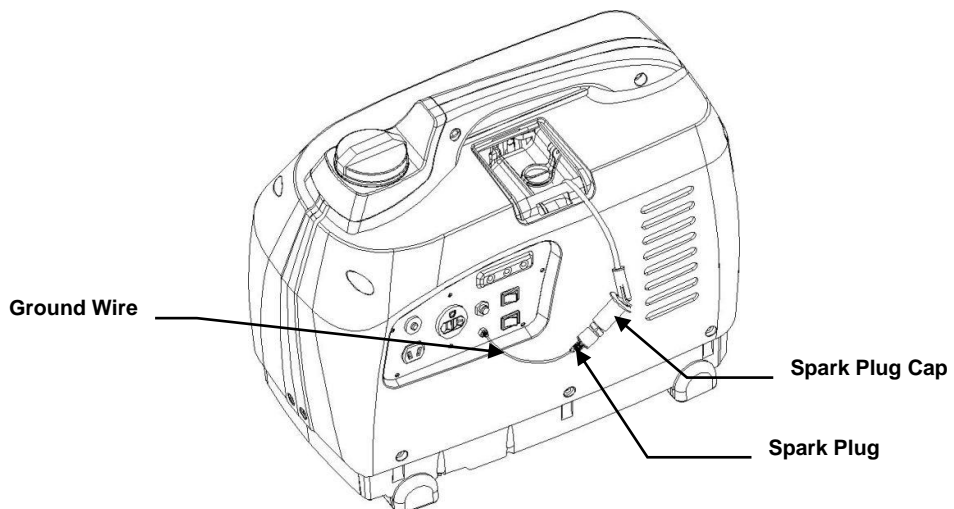
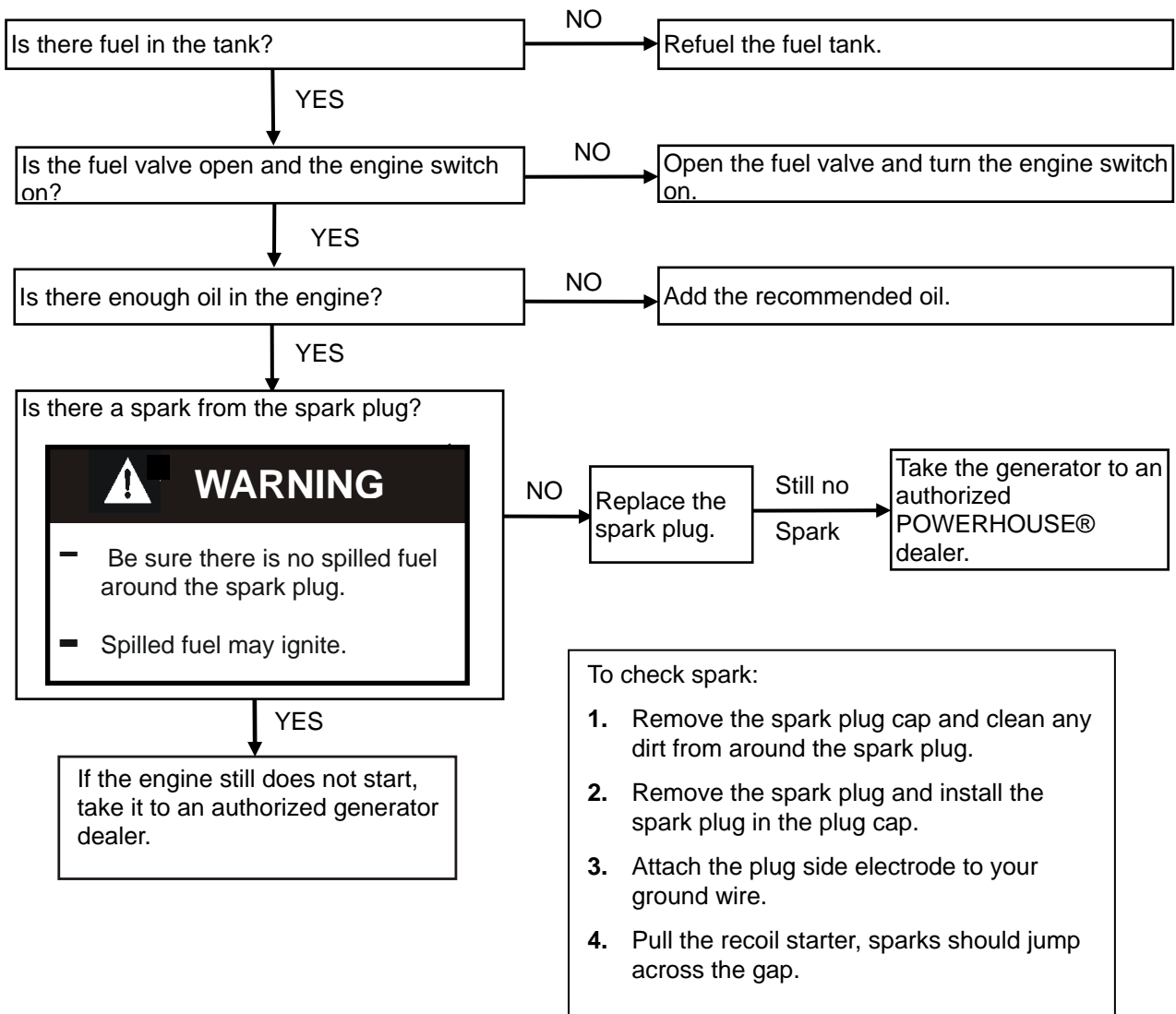

7.2 Appliance does not operate

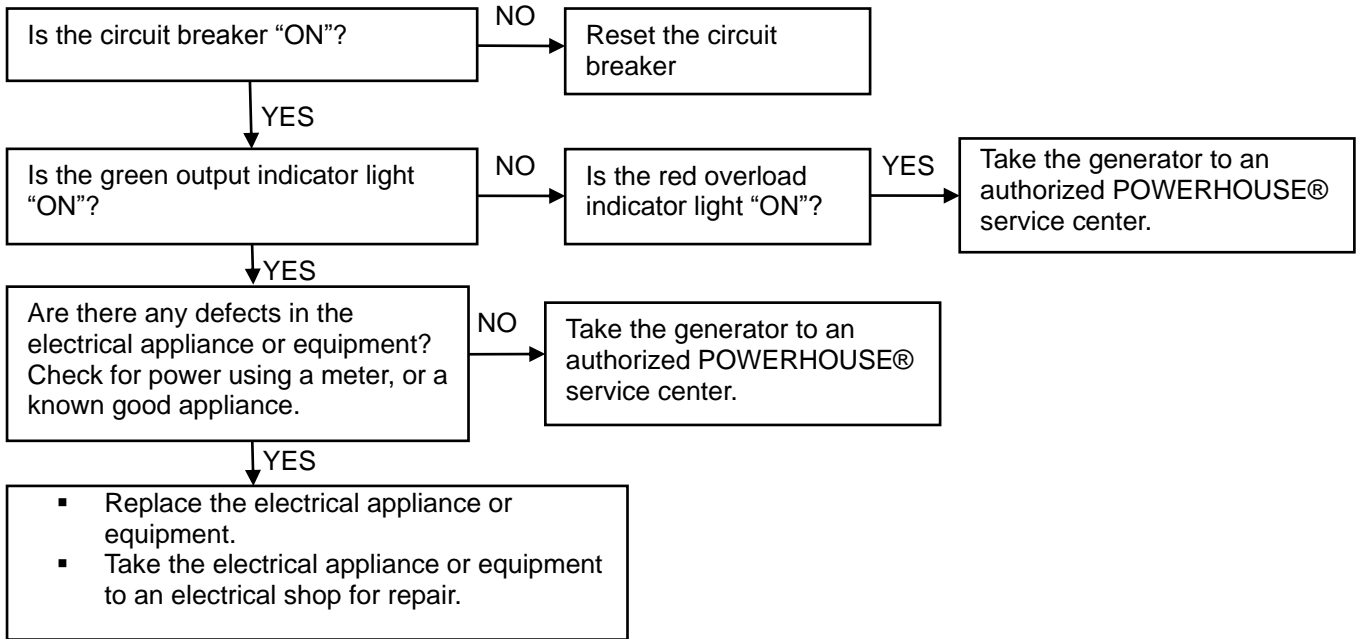

7.3 No output at the DC receptacle

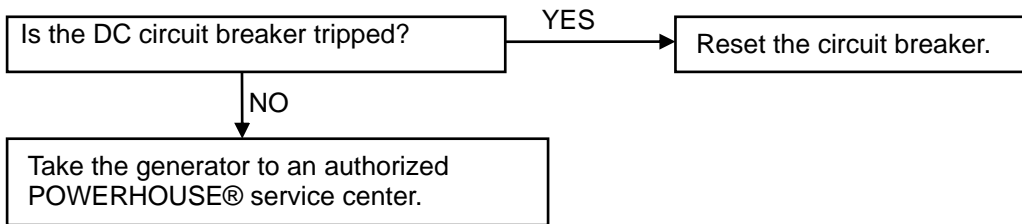

8. SPECIFICATIONS

Generator

Model	1000Wi
Rated frequency (Hz)	60 Hz
Rated voltage (V)	120 V
Rated current (A)	7.5 A
Max current (A)	8.3 A
Rated output (W)	900 W
Max output (W)	1000 W
DC Output	12 V, 5 A
Phase	Single

Engine

Model	XG-SF1000F
Type	4 stroke, vertical shaft, air-cooled, OHC, gasoline engine
Horsepower/Displacement	1.63 / 53 cc
Compression ratio	7.4:1
Engine speed	5500 RPM with economy switch off
Ignition system	Electronic
Spark plug	A7RTC
Starting system	Recoil
Fuel	Automotive unleaded gasoline
Lube oil (synthetic or conventional)	SAE 15W-40 (0W-40 for extreme cold weather)
Oil Capacity	8.5 oz. (250 ml)
Fuel tank capacity	0.78 gal (2.95 L)
Continuous running time at (rated output)	3.5 hours
Continuous running time at (¼ load)	6.9 hours
Continuous running time at (½ load)	5.7 hours
Noise level (no load - full load) dB@ 23' (7m)	64 - 67 dB

Tune Up Specifications

Spark Plug Gap	0.024-0.028 in (0.6-0.7 mm)
Valve Clearance (Intake)	0.0031±0.0039 in (0.08±0.10mm)
Valve Clearance (Exhaust)	0.0039±0.0059 in (0.10±0.15mm)

Dimensions

Overall dimension (H×W×D) in (mm)	17.3 X 20 X 10.8 in (439 x 508 x 274 mm)
Dry weight	33 lbs. (15kg)

9. WARRANTY AND CONSUMER INFORMATION

POWERHOUSE® GENERATOR WARRANTY

Generators are covered by this warranty from the date of original retail purchase for a period of 1 year for residential use and 6 months for commercial applications. Units used in rental fleets, reconditioned or as demonstration models will be considered commercial usage. The warranty coverage is continual from the original date of purchase, and does not restart upon the replacement of any part or complete unit. Individual parts replaced at any point during the warranty period are only eligible for warranty coverage for the balance of the original warranty period.

Eligibility

To be eligible for warranty replacement, the product must be purchased in the United States or Canada from an authorized Coast Distribution dealer. This warranty applies to the original retail purchaser only, and is not transferable. Proof of purchase and the serial number is required.

Coverage

Pre-approved parts and labor costs will be covered by POWERHOUSE® for any failure that is proven to be a failure in material or workmanship under normal use during the applicable warranty time period. This coverage is limited to parts, labor and ground shipping of repair parts. It is the responsibility of the end user to return the product to the nearest authorized repair center as directed by the warranty administration center. If in the event that the generator is deemed to be not repairable or the necessary repair would be economically unfeasible, the warranty department will authorize its prepaid return to the nearest Coast Distribution location and Coast will prepay the returned shipping to the dealer, repair center or consumer. The Coast Distribution System, Inc. reserves the right to repair or replace any part or unit at its option. The Coast Distribution System, Inc. may request defective parts to be returned. Anything replaced under warranty becomes the property of The Coast Distribution system, Inc.

To Obtain Warranty Service

Do not return this generator to the store where you purchased it. Contact any authorized dealer or contact our national customer service center at:

Phone: 1-877-544-4449 (8am to 6pm ET)

Fax: 1-800-263-0280

E-mail: warranty@powerhouse-products.com

If contacting us by fax or e-mail, be sure to include a description of the problem as well as all return contact info such as address, phone number, fax number, e-mail, etc. Engine serial number, barcode number and proof of purchase are required.

Exclusions

THIS WARRANTY DOES NOT EXTEND TO PARTS AFFECTED OR DAMAGED BY ACCIDENT AND/OR COLLISION, NORMAL WEAR, FUEL CONTAMINATION OR DEGRADATION, USE IN AN APPLICATION FOR WHICH THE PRODUCT WAS NOT DESIGNED OR ANY OTHER MISUSE, NEGLIGENCE, INCORPORATION OR USE OF UNSUITABLE ATTACHMENTS OR PARTS, UNAUTHORIZED ALTERATION, OR ANY CAUSES OTHER THAN DEFECTS IN MATERIAL OR WORKMANSHIP OF THE PRODUCT. THIS WARRANTY DOES NOT EXTEND TO NORMAL MAINTENANCE ITEMS SUCH AS BELTS, HOSES, SPARK PLUGS, WHEELS AND FILTERS PAST THE FIRST SCHEDULED REPLACEMENT OR SERVICE INTERVAL FOR THESE ITEMS WHICHEVER COMES FIRST.

Disclaimer of Consequential Damage and Limitation of Implied Warranties

THE COAST DISTRIBUTION SYSTEM, INC. DENIES ANY RESPONSIBILITY FOR LOSS OF TIME OR USE OF THE PRODUCT, TRANSPORTATION, COMMERCIAL LOSS, OR ANY OTHER INCIDENTAL OR CONSEQUENTIAL DAMAGE. ANY IMPLIED WARRANTIES ARE LIMITED TO THE DURATION OF THIS WRITTEN LIMITED WARRANTY.

Some states do not allow limitations on how long an implied warranty lasts and/or do not allow the exclusion or limitation of incidental or consequential damages. Therefore, the above exclusions and limitations may not apply to you. This warranty gives you specific legal rights, and you may also have other rights, which vary from state to state.

Replacement Parts Availability

To purchase replacement parts please refer to the www.powerhouse-products.com website.

CALIFORNIA EMISSIONS CONTROL WARRANTY STATEMENT

Your Warranty Rights and Obligations

The California Air Resources Board and The Coast Distribution System, Inc. (POWERHOUSE®) are pleased to explain the emissions control system warranty on your 2008 and later small off-road engine (SORE). In California, new SOREs must be designed, built, and equipped to meet the State's stringent anti-smog standards. The Coast Distribution System, Inc. (POWERHOUSE®) must warrant the emissions control system on your SOREs for the periods of time listed below provided there has been no abuse, neglect or improper maintenance of your SOREs.

Your emission control system may include parts such as the carburetor, fuel tanks, fuel caps, fuel lines, the ignition system, and catalytic converter. Also included may be hoses, belts, clamps, connectors and other emission-related assemblies.

Where a warrantable condition exists, The Coast Distribution System, Inc. will repair your small off-road engine at no cost to you including diagnosis, parts, and labor.

Manufacturer's Warranty Coverage

The emissions control system is warranted for two years. If any emissions-related part on your engine is defective, the part will be repaired or replaced by The Coast Distribution System, Inc.

Owner's Warranty Responsibilities

- As the SORE owner, you are responsible for the performance of the required maintenance listed in your Owner's Manual. The Coast Distribution System, Inc. recommends that you retain all receipts covering maintenance on your SORE, but The Coast Distribution System Inc. (POWERHOUSE®) cannot deny warranty solely for the lack of receipts or for your failure to ensure the performance of all scheduled maintenance.
- As the SORE owner, you should however be aware that The Coast Distribution System, Inc. may deny your warranty coverage if your SORE or a part has failed due to abuse, neglect, improper maintenance or unapproved modifications.
- You are responsible for presenting your SORE to distribution center or service center authorized by The Coast Distribution System, Inc. (POWERHOUSE®) as soon as the problem exists. The warranty repairs should be completed in a reasonable amount of time, not to exceed 30 days.

If you have any questions regarding your warranty coverage, you should contact the North America service center for POWERHOUSE® products:

Phone: 1-877-544-4449 (8am to 6pm ET)

Fax: 1-800-263-0280

E-mail: warranty@powerhouse-products.com

EMISSION CONTROL SYSTEM WARRANTY

Your POWERHOUSE® generator engine complies with U.S. Environmental Protection Agency, Environment of Canada, and the state of California (if the model is certified by CARB). The following systems and/or parts are covered by this warranty. Failures or improper operation of the following systems and components will be diagnosed and repaired with no charge for labor or parts.

Fuel System

- Carburetor including the choke system
- Engine speed control system (Economy Throttle)
- Intake manifold
- Engine control module

Evaporative Control System

- Fuel tank
- Fuel cap
- Fuel strainer
- Fuel valve
- Fuel pump
- Fuel lines
- Carbon canister (including brackets and connectors)

Air Induction System

- Air filter element*
- Air filter housing

Ignition system

- Ignition module
- Ignition coil
- Ignition winding
- Spark plug*
- Spark plug cap and wire

Exhaust system

- Catalyst
- Exhaust manifold
- Secondary air injection assembly

Miscellaneous

- Pipes, tubes, hoses and clamps, o-rings, seals, and gaskets associated with the above systems.

* Covered up to the first scheduled replacement only. See the maintenance schedule.

10. APPENDIX B - EMISSION CONTROL SYSTEM

Your generator has an engine that has been approved by the California Air Resources Board. Other than the tune up procedures specified in the maintenance section, no additional maintenance is required.

The emission control system has the following components:

1. **Fuel System:** The fuel tank, cap, indicator and hoses are specially designed and constructed to not allow fuel vapors to permeate and be released to the atmosphere.
2. A carbon activated canister collects gasoline vapors from the fuel tank and returns them to the combustion chamber for burning.
3. A catalyst is built into the muffler to further treat the engine exhaust.
4. A secondary air injection valve adds combustion air to ignite unburned fuel in the exhaust.

Contact your authorized POWERHOUSE® service center to obtain the correct replacement parts and service on this system.

11. APPENDIX C - SAFETY AND CHARGING INSTRUCTIONS

- (a) SAVE THESE INSTRUCTIONS. THIS MANUAL CONTAINS IMPORTANT SAFETY AND OPERATING INSTRUCTIONS.
- (b) WORKING IN THE VICINITY OF A LEAD-ACID BATTERY IS DANGEROUS. BATTERIES GENERATE EXPLOSIVE GASES DURING NORMAL BATTERY OPERATION. FOR THIS REASON IT IS OF THE UTMOST IMPORTANCE THAT EACH TIME BEFORE USING YOUR CHARGER, YOU READ AND FOLLOW THE INSTRUCTIONS PROVIDED EXACTLY.
- (c) TO REDUCE RISK OF BATTERY EXPLOSION, FOLLOW THESE INSTRUCTIONS AND THOSE MARKED ON THE BATTERY.
- (d) NEVER SMOKE OR ALLOW AN OPEN SPARK OR FLAME IN THE VICINITY OF THE BATTERY OR ENGINE.
- (e) USE CHARGER FOR CHARGING A LEAD-ACID BATTERY ONLY. IT IS NOT INTENDED TO SUPPLY POWER TO AN EXTRA-LOW-VOLTAGE ELECTRICAL SYSTEM OR TO CHARGE DRY-CELL BATTERIES. CHARGING DRY-CELL BATTERIES MAY CAUSE THEM TO BURST AND CAUSE INJURY TO PERSONS AND DAMAGE TO PROPERTY.
- (f) NEVER CHARGE A FROZEN BATTERY.
- (g) IF IT IS NECESSARY TO REMOVE BATTERY FROM VEHICLE TO CHARGE IT, ALWAYS REMOVE GROUNDED TERMINAL FROM BATTERY FIRST. MAKE SURE ALL ACCESSORIES IN THE VEHICLE ARE OFF IN ORDER TO PREVENT AN ARC.
- (h) STUDY ALL BATTERY MANUFACTURER'S SPECIFIC PRECAUTIONS SUCH AS REMOVING OR NOT REMOVING CELL CAPS WHILE CHARGING AND RECOMMENDED RATES OF CHARGE.
- (i) FOR A CHARGER HAVING AN OUTPUT VOLTAGE SELECTOR SWITCH, REFER TO THE CAR OWNER'S MANUAL IN ORDER TO DETERMINE THE VOLTAGE OF THE BATTERY AND TO MAKE SURE THE OUTPUT VOLTAGE IS SET AT THE CORRECT VOLTAGE. IF AN OUTPUT VOLTAGE SELECTOR SWITCH IS NOT PROVIDED, DO NOT USE THE BATTERY CHARGER UNLESS THE BATTERY VOLTAGE MATCHES THE OUTPUT VOLTAGE RATING OF THE CHARGER.
- (j) NEVER PLACE THE CHARGER DIRECTLY ABOVE OR BELOW THE BATTERY BEING CHARGED; GASES OR FLUIDS FROM THE BATTERY WILL CORRODE AND DAMAGE THE CHARGER. LOCATE THE CHARGER AS FAR AWAY FROM THE BATTERY AS DC CABLES PERMIT.
- (k) DO NOT OPERATE CHARGER IN A CLOSED-IN AREA OR RESTRICT VENTILATION IN ANY WAY.
- (l) CONNECT AND DISCONNECT DC OUTPUT CLIPS ONLY AFTER SETTING ANY CHARGER SWITCHES TO THE OFF POSITION AND REMOVING AC CORD FROM THE ELECTRIC OUTLET. NEVER ALLOW CLIPS TO TOUCH EACH OTHER.
- (m) FOLLOW THESE STEPS WHEN BATTERY IS INSTALLED IN VEHICLE. A SPARK NEAR BATTERY MAY CAUSE A BATTERY EXPLOSION. TO REDUCE RISK OF A SPARK NEAR BATTERY:
 - i. POSITION AC AND DC CORDS TO REDUCE RISK OF DAMAGE BY HOOD, DOOR, OR MOVING ENGINE PARTS;
 - ii. STAY CLEAR OF FAN BLADES, BELTS, PULLEYS, AND OTHER PARTS THAT CAN CAUSE INJURY TO PERSONS;
 - iii. CHECK POLARITY OF BATTERY POSTS. A POSITIVE (POS, P, +) BATTERY POST USUALLY HAS A LARGER DIAMETER THAN A NEGATIVE (NEG, N, -) POST;
 - iv. DETERMINE WHICH POST OF BATTERY IS GROUNDED (CONNECTED) TO THE CHASSIS. IF NEGATIVE POST IS GROUNDED TO CHASSIS (AS IN MOST VEHICLES), SEE ITEM (v). IF POSITIVE POST IS GROUNDED TO THE CHASSIS, SEE ITEM (vi);
 - v. FOR A NEGATIVE-GROUNDED VEHICLE, CONNECT THE POSITIVE (RED) CLIP FROM BATTERY CHARGER TO POSITIVE (POS, P, +) UNGROUNDED POST OF BATTERY. CONNECT THE NEGATIVE (BLACK) CLIP TO VEHICLE CHASSIS OR ENGINE BLOCK AWAY FROM BATTERY. DO NOT CONNECT CLIP TO CARBURETOR, FUEL LINES, OR SHEET-METAL BODY PARTS. CONNECT TO A HEAVY GAUGE METAL PART OF THE FRAME OR ENGINE BLOCK;

- vi. FOR A POSITIVE-GROUNDED VEHICLE, CONNECT THE NEGATIVE (BLACK) CLIP FROM BATTERY CHARGER TO NEGATIVE (NEG, N, -) UNGROUNDED POST OF BATTERY. CONNECT THE POSITIVE (RED) CLIP TO VEHICLE CHASSIS OR ENGINE BLOCK AWAY FROM BATTERY. DO NOT CONNECT CLIP TO CARBURETOR, FUEL LINES, OR SHEET-METAL BODY PARTS. CONNECT TO A HEAVY GAUGE METAL PART OF THE FRAME OR ENGINE BLOCK;
 - vii. CONNECT CHARGER AC SUPPLY CORD TO ELECTRIC OUTLET; AND
 - viii. WHEN DISCONNECTING CHARGER, TURN SWITCHES TO OFF, DISCONNECT AC CORD, REMOVE CLIP FROM VEHICLE CHASSIS, AND THEN REMOVE CLIP FROM BATTERY TERMINAL.
- (n) FOLLOW THESE STEPS WHEN BATTERY IS OUTSIDE VEHICLE. A SPARK NEAR THE BATTERY MAY CAUSE A BATTERY EXPLOSION. TO REDUCE RISK OF A SPARK NEAR BATTERY:
- i. CHECK POLARITY OF BATTERY POSTS. A POSITIVE (POS, P, +) BATTERY POST USUALLY HAS A LARGER DIAMETER THAN A NEGATIVE (NEG, N, -) POST;
 - ii. ATTACH AT LEAST A 60 CM 6-GAUGE (AWG) INSULATED BATTERY CABLE TO A NEGATIVE (NEG, N, -) BATTERY POST;
 - iii. CONNECT THE POSITIVE (RED) CHARGER CLIP TO THE POSITIVE (POS, P, +) POST OF BATTERY;
 - iv. POSITION YOURSELF AND THE FREE END OF CABLE AS FAR AWAY FROM BATTERY AS POSSIBLE, THEN CONNECT THE NEGATIVE (BLACK) CHARGER CLIP TO FREE END OF CABLE;
 - v. DO NOT FACE BATTERY WHEN MAKING FINAL CONNECTION;
 - vi. CONNECT CHARGER AC SUPPLY CORD TO ELECTRICAL OUTLET; AND
 - vii. WHEN DISCONNECTING CHARGER, ALWAYS DO SO IN REVERSE SEQUENCE OF CONNECTING PROCEDURE AND BREAK FIRST CONNECTION WHILE STANDING AS FAR AWAY FROM BATTERY AS PRACTICAL.
- (o) USE OF AN ADAPTER IS NOT ALLOWED IN CANADA. IF A GROUNDING TYPE RECEPTACLE IS NOT AVAILABLE, DO NOT USE THIS APPLIANCE UNTIL THE PROPER OUTLET IS INSTALLED BY A QUALIFIED ELECTRICIAN.
- (p) THE GENERATOR (STATOR WINDING) IS ISOLATED FROM THE FRAME AND FROM THE AC RECEPTACLE GROUND PIN.
- (q) ELECTRICAL DEVICES THAT REQUIRE A GROUNDED RECEPTACLE PIN CONNECTION WILL NOT FUNCTION IF THE RECEPTACLE GROUND PIN IS NOT FUNCTIONAL.



POWERHOUSE® Products
DTS Manufacturing
7930 S.W. Burns Way, Unit C
Wilsonville, OR 97070
www.powerhouse-products.com

BCN # Label For This Unit

This manual version applies to BCNs equal to or greater than:

121115405202001

1000Wi OM (Revision – 2012-10-17)