

# INSTALLATION INSTRUCTIONS

## For Model 410 Wobbler horn

The addition of a Wolo horn kit in your vehicle will provide an extra level of sound. The Wolo name, with more than twenty years experience, is your guarantee of a superior horn product. If you need help installing your new Wolo horn, our technicians are available to answer your questions, Monday thru Friday, from 9 AM to 4 PM EST at 1-888-550-HORN (4676).

1. Install the compressor in the engine compartment in a dry location and safe from engine and exhaust manifold heat. To secure the compressor, drill a 3/16-inch hole. Mount compressor vertically (air outlets at the top). Install the head of the bolt into the slot on the compressor's housing and secure to the vehicle using the lock washer/nut provided. (See Fig. A).

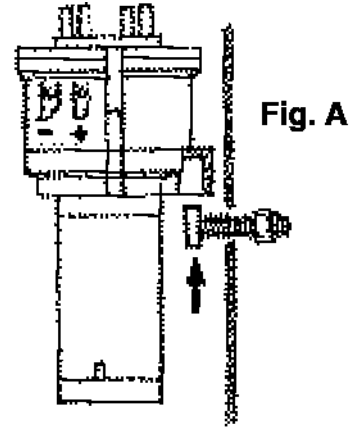

2. Position each trumpet with open end facing down, mark and drill a 1/4-inch hole for each trumpet. Secure to vehicle referring to Figure B. Use mounting hardware in order shown - spacer, lock washer/nut.

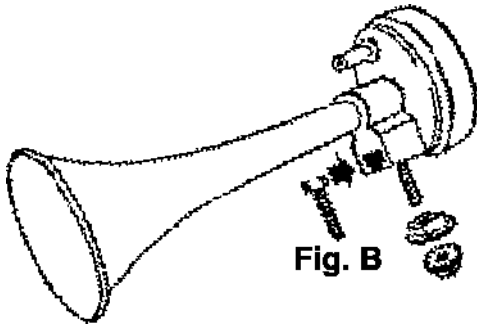

**3. IMPORTANT:** Mount trumpets with the open ends facing down. This will prevent water from entering into the trumpets and compressor. **Water damage to the horn's component parts is not covered by our factory warranty.**

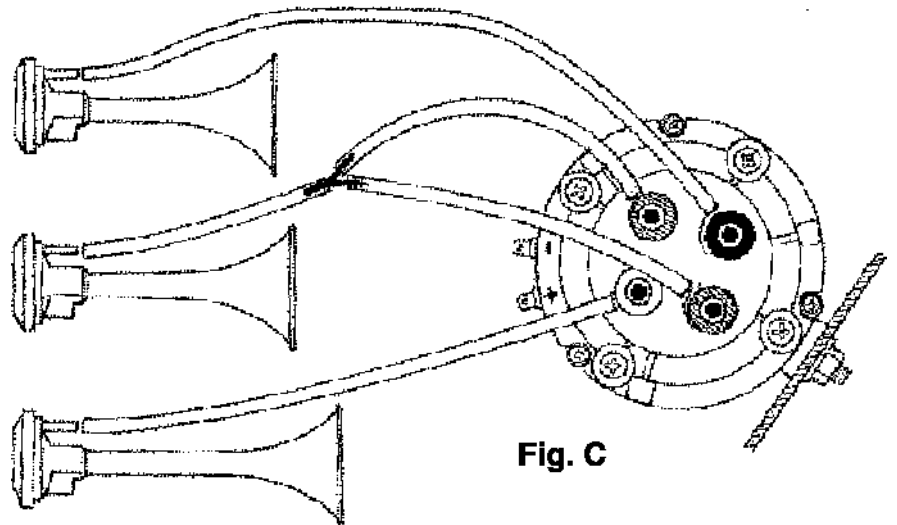

4. Using plastic air tubing included in the kit, cut to proper length and install referring to Figure C. The inlet fitting on each trumpet has a colored ring. When connecting the plastic tubing, mate with the same color ring on the compressor outlet fitting. **CAUTION:** Avoid making any kinks or sharp bends in tubing that will restrict the airflow and alter the horn's sound.

## ELECTRICAL CONNECTIONS USING VEHICLE'S FACTORY HORN SWITCH

**For a vehicle with a (2) wire system:** If vehicle's factory horn has two (2) terminals, simply transfer the wires to the terminals on the bottom of the compressor. **IMPORTANT:** when testing the horns, if compressor motor turns on but the horn does not sound, reverse the wires connected at the bottom of the compressor.

**For a vehicle with a (1) wire system:** If vehicle's factory horn has two (1) terminal, simply transfer wire to the compressor's positive (+) terminal on bottom of compressor. The compressor's negative terminal is connected to any metal body ground. Connection should be free of rust or paint.

## ELECTRICAL CONNECTIONS FOR A NEW HORN BUTTON SWITCH:

Install the relay in a dry location with the terminals facing downward near the compressor. Refer to figure 4 for wiring.

- Connect relay terminal 87 to the positive terminal at the bottom of the compressor. Use no less than a 16-gauge wire.
- Connect relay terminal 85 to the horn switch terminal. The other horn switch terminal is connected to ground (body of vehicle). An 18-gauge wire is suggested for this connection.
- Connect relay terminals 30/86 to positive (+) 12-volt battery, alternator or accessories. Use 16-gauge or heavier wire. A 20-ampere fuse is suggested to be installed as shown in Figure D.

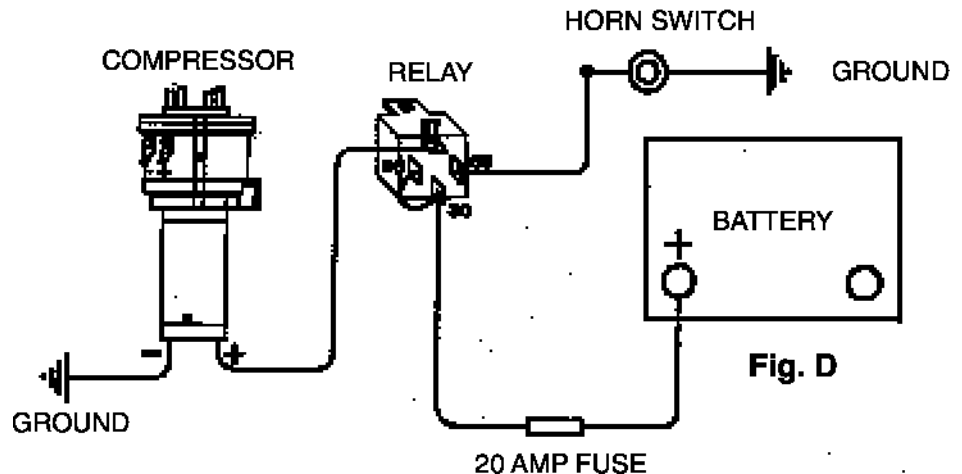

## TOGGLE SWITCH INSTALLATION

The toggle switch, included in kit, will control the horn's sounds. One position for a steady three trumpet sound and the other will produce a turkey sound.

- Mount the toggle switch in an accessible location inside the Vehicle.
- Connect one terminal of the toggle switch to ground, any body bolt in the dashboard area. Make sure the surface is clean from dirt and rust so as to make a good electrical connection.
- Connect the other terminal of the toggle switch to the compressor's minus (-) terminal on the side of the compressor using the black wire with the insulated terminal provided.
- Attach the red wire with the insulated terminal to the compressor's positive (+) terminal on the side of the compressor. Splice the other end of the wire to the wire that is connected on the bottom of the compressor's motor marked positive (+), as shown in Fig. E.

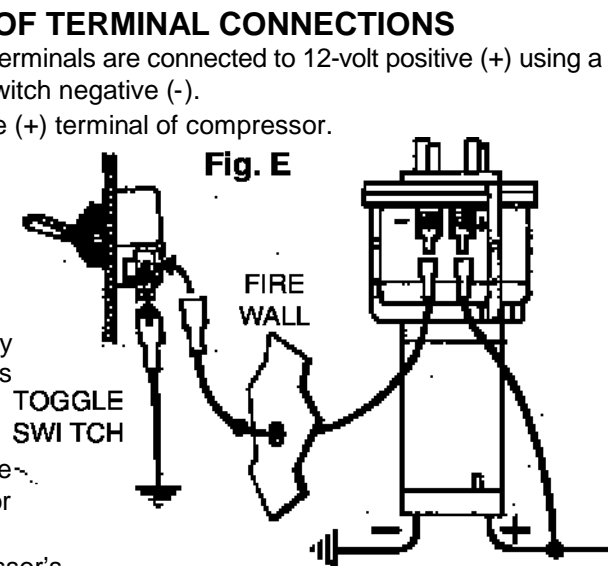

## RECAP OF TERMINAL CONNECTIONS

Terminals 30/86: the two (2) terminals are connected to 12-volt positive (+) using a fuse.

Terminal 85: connect horn switch negative (-).

Terminal 87: connect positive (+) terminal of compressor.

## Warranty

Wolo Manufacturing Corporation ("Wolo") warranties to the original purchaser, for three months from the date of purchase, that this product is free from defects in workmanship and materials. If there is such a proven defect, Wolo, at its option, will either repair or replace the item free of charge, if it is returned to Wolo within three months from the date of purchase together with proof of purchase as described below. Wolo reserves the right to inspect any defect prior to settling any warranty claim by repair or replacement. This warranty is limited as above provided and Wolo will not be responsible for fire or other casualty or accident, due to neglect, abuse, abnormal use, modifications, faulty installation of this product, or natural causes.

ANY EXPRESSED WARRANTY NOT PROVIDED HEREIN IS EXCLUDED AND DISCLAIMED. THE IMPLIED WARRANTIES OF MERCHANTABILITY AND OF FITNESS FOR A PARTICULAR PURPOSE ARE EXPRESSLY LIMITED TO A TERM OF THREE (3) MONTHS. UNDER NO CIRCUMSTANCES SHALL WOLO BE LIABLE TO PURCHASER OR ANY OTHER PERSON FOR ANY SPECIAL OR CONSEQUENTIAL DAMAGES, WHETHER ARISING OUT OF BREACH OF WARRANTY OR OTHERWISE.

To obtain warranty service, return the product prepaid, and include the original bill of sale showing the date of purchase. Provide with the return a brief description of the problem. Also, include with the return a check or money order in the amount of \$10.00 to cover return shipping. Mail to:

**Wolo Manufacturing Corp. One Saxwood Street, Deer Park, NY  
11729 Attn: Warranty Service [E-mail: tech@wolo-mfg.com](mailto:tech@wolo-mfg.com)**

© 2006 Wolo Mfg. Corp All Rights Reserved.