



Western
Steel & Tube

Warning:

Failing to follow ALL of these instructions could result in personal injury.

- 1. Never overload ramps. Maximum capacity for your ramp is printed on the ramp warning label (all loads must be evenly distributed).***
- 2. Always use safety straps to securely fasten the ramps to the vehicle. The straps are designed to prevent the ramp from slipping off of the tailgate.***
- 3. Carefully roll or winch equipment up or down ramp. Never drive or ride your equipment while loading or unloading.***
- 4. Make sure the ramps are aligned with the wheels of the equipment being loaded or unloaded.***
- 5. Always load or unload on a solid, level surface with the vehicle in gear, parking brake on, and engine off.***
- 6. Inspect ramp before each use. Tighten any loose hardware, replace any worn or damaged parts. Replace safety straps if webbing is frayed or worn. Proper care and maintenance of the ramps is essential to safety.***

Proper use of this product is critical to safety and beyond the control of Western Steel & Tube Ltd. Western Steel & Tube Ltd. neither guarantees, nor will it be liable for any damage resulting from improper use. The liability of this product is limited to its purchase price if it proves to be defective in material and/or workmanship. Warranty information is available upon request.



Western Steel & Tube **7 ft. & 8 ft. Arched Truck Box Ramp Assembly And Use Instructions**

Step 1 Verify all parts are present:

Required Tools: 7/16" and 9/16" socket with extension, adjustable wrench.

Hardware Package
With Red Caps

2 Pcs

Track Bar
Bundle

40 Pcs (7 ft), or 48 Pcs (8 ft)

Hardware Package
With Cargo Straps

2 Pcs

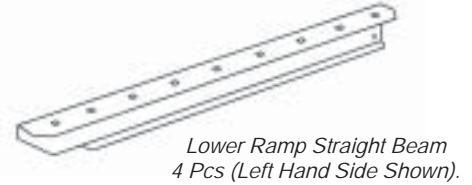
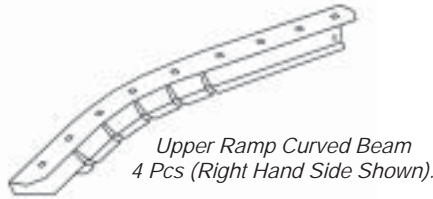

**If Any Parts Are Missing - Please Do Not Call The Store.
Call Our Customer Service Line - Toll Free 1-888-335-4507.**

Step 2 Assemble Upper Ramp Section:

Select the required parts as shown below. **ALL Track bars must be installed with edges pointing upwards to be in contact with the tires.** This will provide maximum traction and will not harm your tires. **Do not over tighten nuts. Doing so will crush or flatten the track bars.**

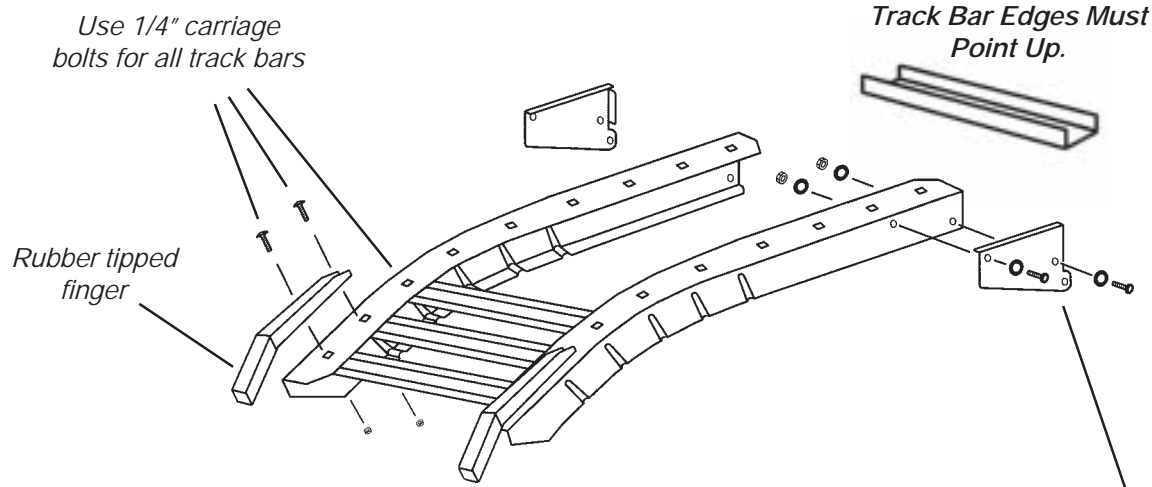

Step 3 Assemble Lower Ramp Section:

Select the required parts and assemble as shown below.

Attach 4 knee joint plates as shown. Use 3/8" hex bolts and washers. **These bolts must be tight!**

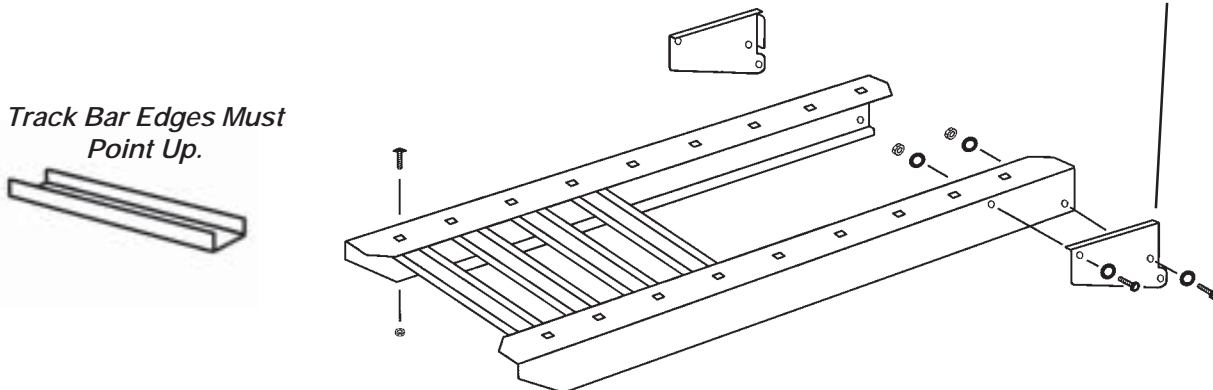

Step 4 Connect Upper And Lower Sections:

Use the 3/8" bolts to connect the upper and lower ramp sections together (see figure). Apply protective tailgate trim to leading edges. The second ramp can now be assembled by repeating step 2 to 4.

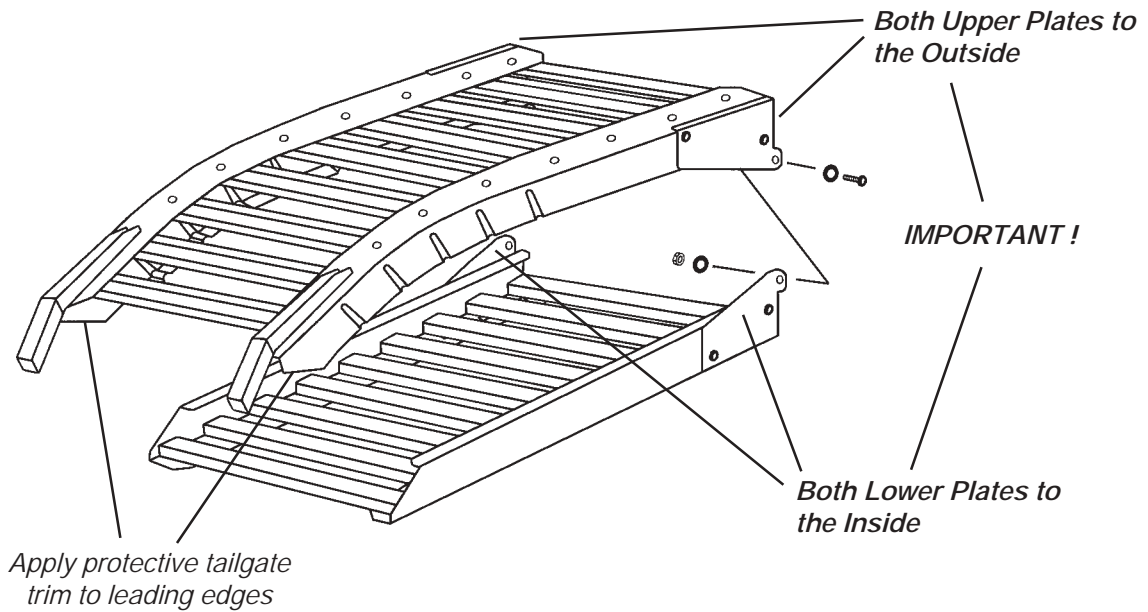

Step 5 Attach Safety Strap:

A safety strap is required to prevent the ramp from slipping off the end of the truck tailgate. The strap is supplied with a hook on each end (see sketch below). Attach one hook to the third track bar from the top of the ramp. Attach the other hook to an anchor point on the truck bumper directly below and in line with the ramp. Pull loose strap end to tighten, press buckle to release. **Straps must be tight to keep the ramps firmly against tailgate during loading or unloading.** Store straps indoors after use.

