



an EnPro Industries company

QPHT Series Refrigerated Air Dryers



Instruction Manual

This manual contains important safety information and should be made available to all personnel who operate and/or maintain this product. Carefully read this manual before attempting to operate or perform maintenance on this equipment.

Manual No. 65505-2A

April 2008 Edition

Table of Contents

General Information	1
Receiving – Inspection.....	1
Safety Instructions	2
Disclaimer of Warranty	3
Installation Instructions.....	4
Operating Instructions.....	9
Specifications	10
Maintenance & Adjustments	11
Troubleshooting	14
QPHT 25 Parts Lists	15
QPHT 50 Parts Lists	16
QPHT 75 Parts Lists	17
QPHT 100 Parts Lists	18
QPHT 125 Parts Lists	19
QPHT 25 Dimensional	20
QPHT 50 Dimensional	21
QPHT 75/100/125 Dimensional	22
QPHT 25 Wiring Diagram.....	23
QPHT 50 Wiring Diagram.....	24
QPHT 75 (115V) Wiring Diagram.....	25
QPHT 75 (230V) Wiring Diagram.....	26
QPHT 100/125 (115V) Wiring Diagram	27
QPHT 100/125 (230V) Wiring Diagram	28

High Temperature Refrigerated Air Dryers

DATE OF PURCHASE:
MODEL:
SERIAL NO.:
Record above information from nameplate. Retain this information for future reference.

General Information

Quincy Models QPHT 25, 50, 75, 100 and 125 High Temperature Refrigerated Dryers are designed to cool and remove moisture from compressed air. The units cool air in two stages. Compressed air enters the system at a maximum temperature of 180°F and is cooled in an aftercooler by ambient air. It is further cooled in an air to refrigerant heat exchanger to about 40°F. Once cooled, the air is sent through an automatic draining moisture separator and finally through an optional oil filter.

When properly installed, the units require little maintenance or adjustment. A list of service parts is provided in the Parts List and Drawings book (9829 2101 99). Contact Quincy or your Quincy distributor for repair or replacement of other parts on these units.



WARNING!

DO NOT install, operate, maintain, adjust or service this unit without thoroughly reading this manual.

This manual contains important safety information. Read **THOROUGHLY** and follow the Safety Instructions provided in this manual and posted on the unit. Keep this manual near the unit and in a safe place. Replace this manual if it becomes torn or dirty and cannot be properly used.

Please read the Operating Instructions section of this manual before attempting to operate the unit.

Please read the Maintenance & Adjustments and Troubleshooting sections of this manual before beginning any maintenance or service work on this unit.

Contact Quincy or your Quincy distributor before performing any service or maintenance work NOT discussed in this manual.

Receiving – Inspection

Inspect equipment. Any concealed shipping damage must be reported to the carrier immediately. Damage claims should be filed by the consignee with the carrier.

All the equipment shipped F.O.B. factory becomes the property of the purchaser. In all cases of damage, visible or suspected,

contact your local distributor or Quincy before attempting to install equipment.

SERVICE INQUIRIES: Provide Model No., Serial No., Operating Pressure, Inlet Temperature, Nature of Problem. See Dryer Specification Tag located on the control panel.

High Temperature Refrigerated Air Dryers

Safety Instructions

When using air compressors and compressed air accessories, basic safety rules and precautions must always be followed, including the following:

READ ALL INSTRUCTIONS FULLY.

Wiring & Breakers

Wiring, breakers and other electrical equipment must conform to local and national electrical codes. Do not operate this unit with damaged wiring or after the unit or air handling parts have been dropped or damaged in any manner. Notify authorized service facility for examination, repair or other adjustments.



WARNING!

Comply with the National Electrical Code, Federal, State and Local Codes when installing or operating this unit.

COALESCING OIL FILTER (OPTIONAL) – CHANGING AND REMOVING

Shut off power and discharge all pressure from this unit and air system before removing or adding parts or attachments and before maintaining unit.

INSPECT HOSES

Regularly inspect hoses and load handling fittings for signs of damage, deterioration, weakness or leakage. Do not use if a defect is found. Remove dryer from service and repair or discard defective parts. Keep hoses away from sharp objects, chemical spills, oil, solvents and wet floors. All of these can damage a hose.

USE SUITABLE PARTS & ACCESSORIES

Do not use air pressurized accessories or parts in the air system not suitable for the maximum air pressure used. Be sure maximum pressure specified by the accessory manufacturer is well above the working pressure of your compressor.

RELEASE AIR PRESSURE SLOWLY

Fast moving air will stir up dust and debris, which may be harmful. Release air pressure slowly when depressurizing your system to avoid bodily injury.

SECURE DRAIN LINES

Fasten drain lines to floor or drain. Pressurized air may periodically pass through drain lines, which will cause an unsecured line to whip and may cause bodily injury.



WARNING!

Air from compressor and from Models QPHT 25, 50, 75, 100 and 125 High Temperature Refrigerated Dryers, as equipped, is not safe for human respiration (breathing).

To provide safe, breathable air, compressor must be capable of producing at least Grade D breathing air as described in Compressed Gas Association Commodity Specification G7.1-1966. Special filtering, purifying and associated alarm equipment must be used to convert compressed air to "Breathing Air." Other special precautions must also be taken.

Refer to OSHA 29 CFR 1910.134.

READ THESE INSTRUCTIONS THOROUGHLY BEFORE USING THIS UNIT.

Disclaimer of Warranty

If this unit is used to produce breathing air, the special equipment and precautions expressed in OSHA 29 CFR 1910.134 for specifications of the necessary equipment and special precautions to make Breathing Air **MUST BE** used or any warranties are VOID and manufacturer disclaims any liability whatsoever for loss, personal injury or damage.

IF USED FOR SPRAYING

- ◆ Follow all labels and printed instructions provided by the manufacturer of the material being sprayed.
- ◆ Spray in an open area away from flames and electrical equipment. Fumes are dangerous. Spray in a well ventilated area to keep fumes from collecting and causing health and fire hazards.
- ◆ Do not spray in vicinity of open flames or other areas where a spark can cause ignition. Do not smoke when spraying paint, insecticides, or other flammable substances. Use a respirator when spraying.
- ◆ Always direct paint or other sprayed material away from compressor and air dryer. Locate these units as far away from painting area as possible to minimize accumulation on equipment. Keep other people away from spraying area.

High Temperature Refrigerated Air Dryers

Installation Instructions

NOTICE!

Improper installation methods of air inlet and air outlet piping that causes internal damage to the air dryer system will void warranty. Installer should follow proper pipe installation practices or hire a certified contractor to install this unit.

NOTICE!

Before installing the air dryer system, make sure that the unit has at least 24 inches of clearance around all sides and at least 24 inches of clearance on top. This is required to provide proper air circulation to the unit. Also, a floor drain must be provided for moisture and oil drainage. The unit must stand above the floor drain by at least an inch or two for proper drainage. If the floor drain is located further from the unit than 3 Ft., obtain longer hoses locally (refer to the installation instruction Step 5 for proper dimensions). If it is impossible to connect the unit to a floor drain, a container can be made to collect the drainage. This container must have a lid to prevent the pressurized drainage from spraying. This lid must have an air hole to allow the air inside to escape when the drainage is discharged.

- ◆ Remove unit from carton and VISUALLY inspect for damage.
- ◆ To install the optional coalescing oil filter, thread a pipe nipple on the air outlet connection. Install the filter to the pipe nipple with arrow on filter pointing away from air dryer unit. Use pipe sealer on both ends of the nipple to facilitate sealing without undue torque pressure.

NOTICE!

Optional coalescing oil filter must be installed with direction arrow facing AWAY from the air dryer system unit. If the oil filter is installed backwards, discharge air will be contaminated with oil.

- ◆ Connect discharge air line to the dryer or optional filter outlet connection.
- ◆ Connect air piping from the air compressor to the air dryer system inlet connection. Use caution when connecting piping to the air dryer system to avoid twisting and damaging the air connection.

NOTICE!

Install brackets and support fixtures as needed to eliminate fatigue and vibration in the air system piping.

- ◆ **Drain Connection** - Models QPHT 25 and QPHT 50 are equipped with a 1/2" OD plastic moisture drain tube. The drain tube needs to be directed to a proper drain point. A longer drain tube or extension may be required. Be sure to provide a secure attachment as the moisture drain tube will periodically be under pressure.
- ◆ **Drain Connection** - Models QPHT 75, 100 and 125 are equipped with a 3/8" NPTF drain connection. A plastic drain tube or copper pipe must be attached and directed to a proper drain point. Be sure to provide a secure attachment as the moisture tube or pipe will periodically be under pressure.



CAUTION!

Moisture drain line must be tightly secured at the drain. This line will periodically contain pressurized air. An unsecured line will whip around. Failure to secure lines can cause bodily injury.

Connect the grounded electrical plug to a standard three-hole grounded outlet. If an extension cord is necessary, use a 14 Gauge extension cord only. Wiring must meet local and national electrical codes.



CAUTION!

Air dryer unit **MUST** be attached to a properly wired and grounded outlet. Failure to properly ground unit can cause electrocution. Observe all local and national electrical codes.

The air dryer system has been tested and shipped with a full charge of oil and refrigerant. Inspect the suction pressure

gauge located on the front of the unit (refer to Figures 1 – 3). While the unit is idle (not operating) the refrigerant suction pressure should be within the range of 90 to 130 PSIG.

If the suction pressure gauge reads 0 PSIG or near 0 PSIG, contact Quincy or your Quincy dealer.



NOTICE!

Air dryer unit will not function properly unless all cabinet panels are in place.



NOTICE!

Do not operate unit in an ambient temperature below 55°F (13°C) or above 100°F (38°C). If the unit has been stored overnight or longer in temperatures below 55°F (13°C), the unit must sit for at least eight hours at a recommended temperature before operating.

High Temperature Refrigerated Air Dryers

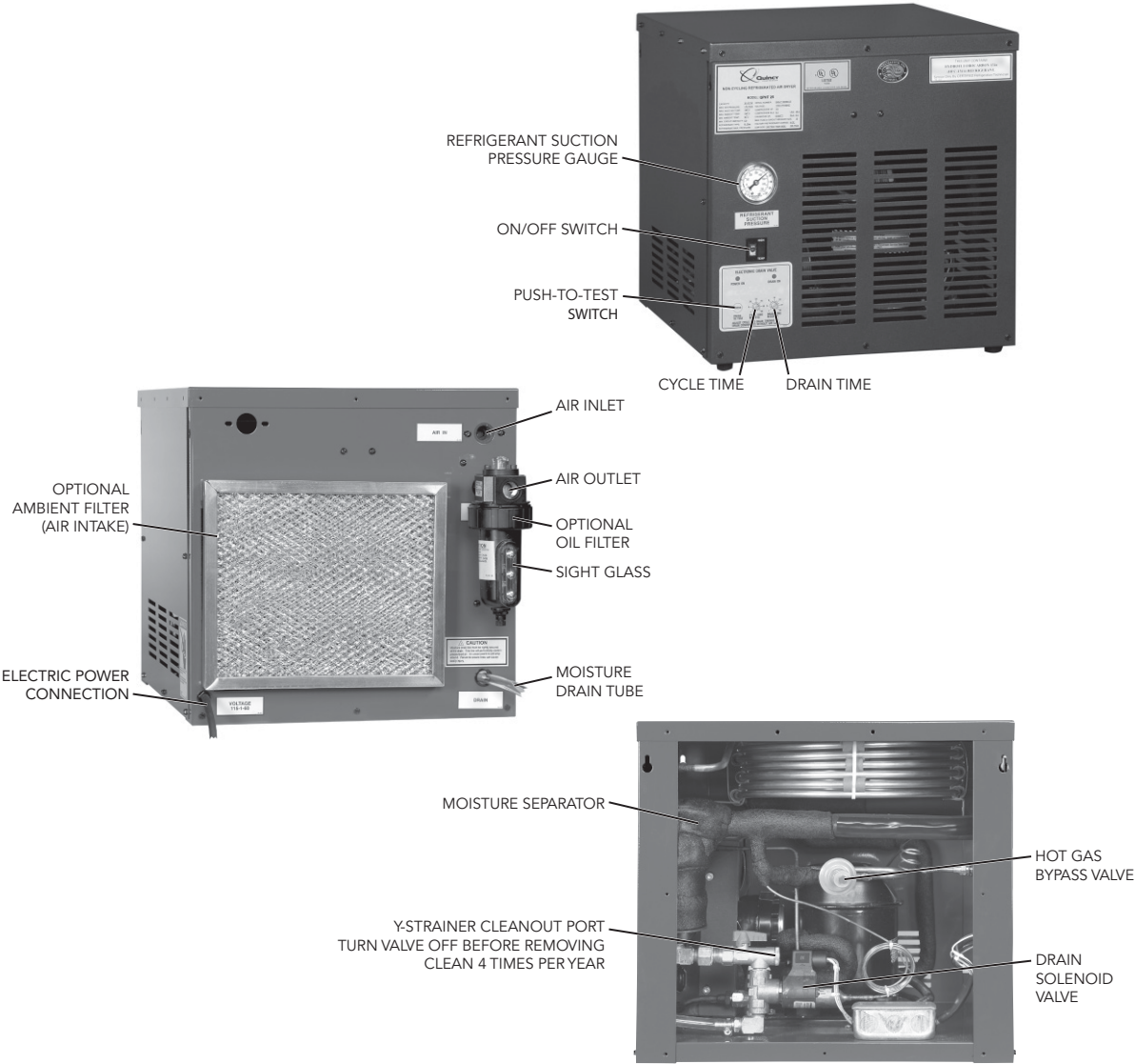

Figure 1 — Model QPHT 25

High Temperature Refrigerated Air Dryers

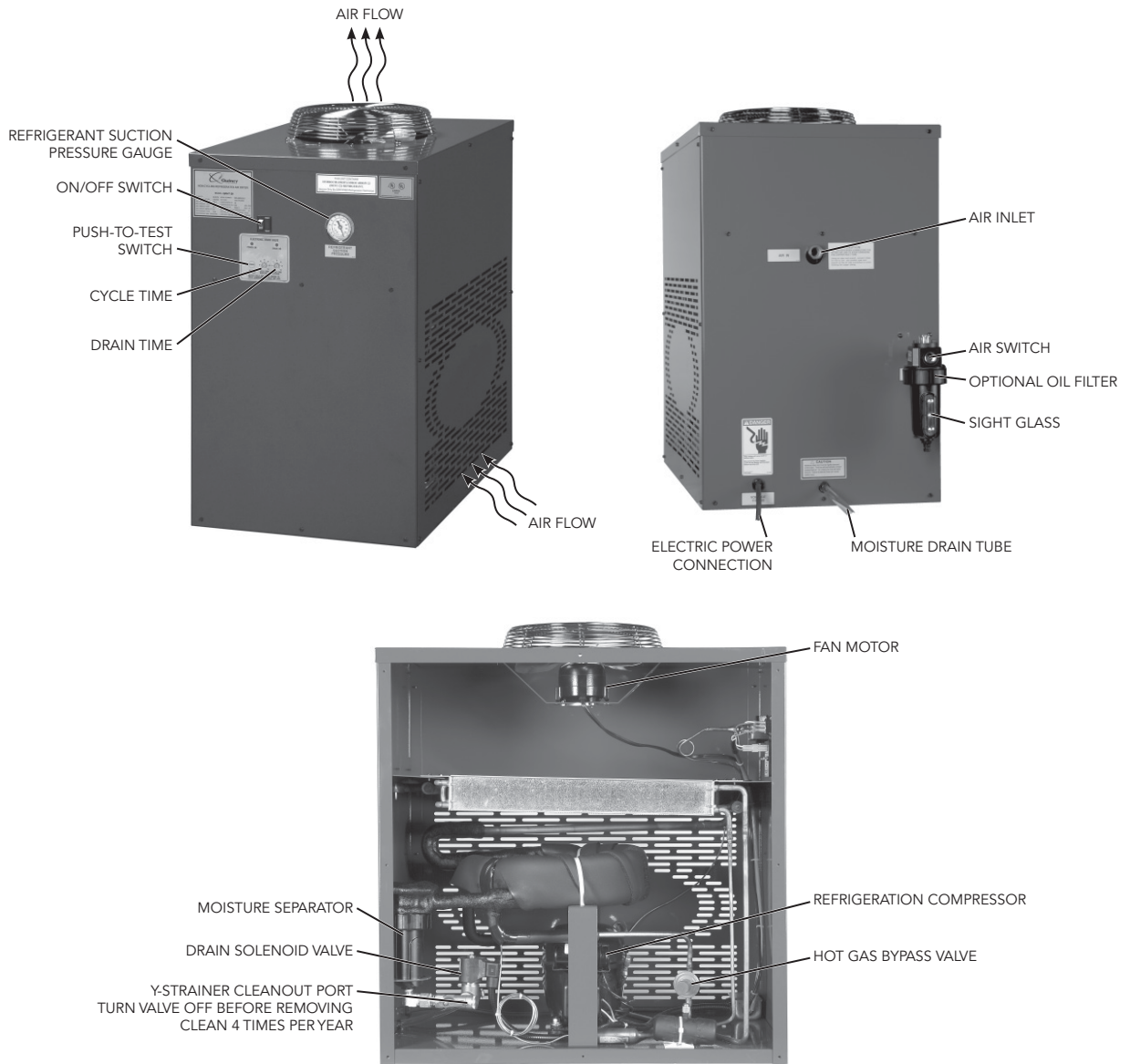

Figure 2 — Model QPHT 50

High Temperature Refrigerated Air Dryers

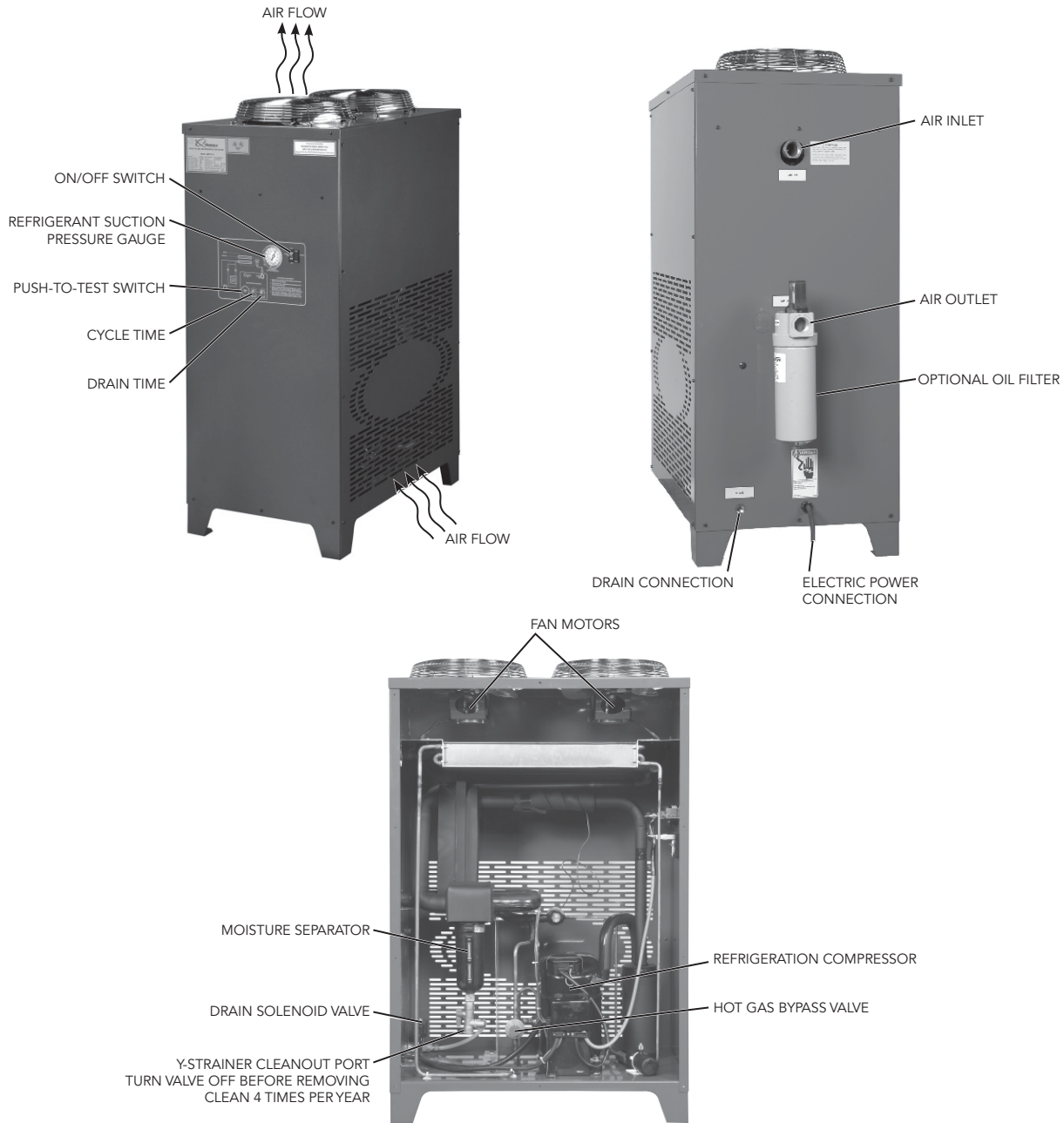

Figure 3 — Model QPHT 75/100/125

Operating Instructions

Start the air dryer system by turning the switch to the ON position. At this time the compressor and cooling fans will start.

After the unit is running, the suction pressure will begin to drop into the appropriate pressure range for the particular dryer model. Normal operating suction pressure range is from 25 to 33 PSIG (blue zone).

Once the suction pressure stabilizes and is maintained in the proper operating pressure range, compressed air can be allowed to flow through the air dryer system. At this point the air dryer system is delivering dry air to your process.

If the refrigerant suction pressure is not in the proper operating range, a hot gas bypass adjustment may be required. See Page 12 for hot gas bypass valve adjustment instructions.

Hold the PUSH-TO-TEST button on the drain controls open for several seconds. This procedure should be repeated 3 or 4 times in every 8 hour period of operation.

The moisture drain valve operates automatically and is controlled with the CYCLE TIME and DRAIN TIME knobs. Initially both knobs should be turned counterclockwise to the seven o'clock position. When using the unit after shipment, check both knobs and turn to the seven o'clock position if they have been moved. The controls are now set so that the unit opens the drain every 1 minute (cycle time) for a 2 second period (drain time).

The cycle time and drain time will need to be set higher if there is an increased load on the dryer and to compensate for humid ambient conditions. Drain settings should be set to allow for proper drainage with minimal pressure loss.

Press the PUSH-TO-TEST button for manual override, and to periodically clear the moisture drain of sediments or foreign material.

Optional Oil Filter: Manually turn the coalescing oil filter drain stem once every 8 hours of operation, or when the sight of glass is half full of liquid. Failure to drain may cause reentrainment.

High Temperature Refrigerated Air Dryers

Specifications

Model QPHT 25

Unit Dimensions:

Length: 17.50"

Width: 18.75"

Height: 17.75"

Flow:

25 SCFM

Inlet Pressure:

175 PSIG (200 PSIG Maximum)

Ambient Temperature:

Minimum 55°F (13°C)

Maximum 100°F (38°C)

Inlet Temperature:

180°F (82°C) Maximum

Dew Pt. Temperature:

50°F±2° (10°C±1°)

Refrigerant H.P.:

1/4

Heat Exchanger Material:

Copper

Automatic Drain:

Installed

Refrigerant:

R-134A

Electrical Power Supply:

115V, 60Hz, 1 phase

Instrumentation:

ON/OFF switch

Power-on light

High temperature light

Refrigerant suction pressure gauge

Drain test button

Drain timer adjustment controls (2)

Model QPHT 50

Unit Dimensions:

Length: 28"

Width: 18"

Height: 30"

Flow:

50 SCFM

Inlet Pressure:

175 PSIG (200 PSIG Maximum)

Ambient Temperature:

Minimum 55°F (13°C)

Maximum 100°F (38°C)

Inlet Temperature:

180°F (82°C) Maximum

Dew Pt. Temperature:

50°F±2° (10°C±1°)

Refrigerant H.P.:

1/3

Heat Exchanger Material:

Copper

Automatic Drain:

Installed

Refrigerant:

R-134A

Electrical Power Supply:

115V, 60Hz, 1 phase

Instrumentation:

ON/OFF switch

Power-on light

High temperature light

Refrigerant suction pressure gauge

Drain test button

Drain timer adjustment controls (2)

High Temperature Refrigerated Air Dryers

Model QPHT 75/100/125

Unit Dimensions:

Length: 28"

Width: 18"

Height: 40"

Flow:

QPHT 75: 75 SCFM

QPHT 100: 100 SCFM

QPHT 125: 125 SCFM

Inlet Pressure:

175 PSIG (200 PSIG Maximum)

Ambient Temperature:

Minimum 55°F (13°C)

Maximum 100°F (38°C)

Inlet Temperature:

180°F (82°C) Maximum

Dew Pt. Temperature:

50°F±2° (10°C±1°)

Refrigerant H.P.:

QPHT 75: 1/2

QPHT 100: 3/4

QPHT 125: 3/4

Heat Exchanger Material:

Stainless Steel & Copper

Automatic Drain:

Installed

Refrigerant:

R-134A

Electrical Power Supply:

115V, 60Hz, 1 phase

Instrumentation:

ON/OFF switch

Power-on light

High temperature light

Refrigerant suction pressure gauge

Drain test button

Drain timer adjustment controls (2)

Maintenance & Adjustments

- ◆ The ON/OFF switch holds a HIGH TEMP light which will turn on if the unit's compressor system malfunctions. If the red HIGH TEMP light on this switch is illuminated, turn off and unplug the unit for 15 minutes and restart. If the light remains on after restarting or it continues to turn on afterwards, contact Quincy or your distributor.
- ◆ **Periodic maintenance** - The following procedures should be performed every six months to insure that the air dryer unit operates properly. These steps should be performed more frequently

if either the air compressor or the air dryer is exposed to air that is dirtier or dustier than normal.

- a. Clean optional ambient filter.
- b. Clean optional coalescing oil filter drain assembly
- c. Replace optional coalescing oil filter element
- d. Clean moisture separator drain assembly
- e. Clean Particle Strainer
- f. Clean condenser/air cooler coil.

High Temperature Refrigerated Air Dryers

Optional ambient filter cleaning - Remove ambient filter from the air dryer system unit and simply flush the filter in a stream of water to remove any dust and dirt. Allow filter to dry and spray on a filter coat adhesive to help trap dust and dirt. If the ambient filter will not come clean, replace with new filter. Refer to the Parts List and Drawings book (9829 2101 99) to order ambient filters or the filter spray-on coat adhesive. Replace ambient filter with the arrow on the filter pointing towards the unit for proper air flow through the filter and into the unit.

Optional coalescing oil filter - The filter is equipped with a pressure differential indicator. The indicator should be inspected periodically each 24 hour period. If the indicator is at or above the midpoint on the gauge, the filter element should be replaced and the drain assembly cleaned. Filters for models QPHT 25 and QPHT 50 are equipped with a ball type indicator gauge. Filters for models QPHT 75, QPHT 100 and QPHT 125 are equipped with a numeric color type indicator gauge.

- a. Depressurize the air system to release compressed air from the air dryer system. Shut down the air compressor AND the air dryer system, and discharge the air through the sprayer or other output device. Shutting down the air compressor or dryer only will not depressurize the air dryer system.



WARNING!

Depressurize air dryer system before removing coalescing oil filter bowl. Failure to do so will cause the filter to blow off its fitting and cause bodily injury and property damage.

- b. Remove the filter bowl, the bottom half of the assembly, by turning the bowl counterclockwise.
- c. Clean the bowl and the drain stem with water and a mild soap solution.

NOTICE!

When reinstalling the filter bowl, make sure the O-ring is in place on the top half of the filter housing and that the O-ring seats properly. Air leaks may occur if O-ring is not seated.

- d. Optional oil filter - Inspect the coalescing oil filter every 6 months and replace element as necessary. Refer to the Parts List and Drawings book (9829 2101 99) to order a filter element.
- e. If the drain is clean and the filter still will not drain, contact Quincy or your distributor to order a new filter assembly.

Moisture separator drain cleaning - If after using the PUSH-TO-TEST button to clear sediment or foreign objects from the moisture drain, and the drain still appears to be clogged, depressurize the air system to release compressed air from the air dryer unit. Shut down the air compressor AND the air dryer unit, and discharge the air through the sprayer or other output device. Shutting down the air compressor unit only will not depressurize the air dryer unit.



WARNING!

Depressurize air dryer system before removing moisture separator bowl. Failure to do so will cause the separator to blow off its fitting and cause bodily injury and property damage.

- a. Remove the screws attaching the left side panel to the cabinet and remove the panel. (Refer to Figures 1 – 3.)

 **NOTICE!**

The air dryer system will not operate properly unless all panels are reinstalled after any maintenance work.

- b. Remove compression fitting on the elbow attached to the particle strainer of the separator assembly by turning the hex head nut on the fitting. Remove the plastic tubing connecting the particle strainer and the drain valve solenoid.
- c. Close the shut-off valve on the particle strainer, drain the down stream line of the particle strainer with the PUSH-TO-TEST button on the auto drain. Unscrew and clean out screen, replace screen and open shut-off valve.
- d. Remove lower bowl bracket by unfastening the two machine screws and nuts that hold the lower bracket to the back panel.
- e. Turn the separator bowl counterclockwise to remove. A pipe wrench may be necessary to remove the bowl.

 **NOTICE!**

When reinstalling the separator bowl, make sure the O-ring is in place on the top of the bowl and that the O-ring seats properly on the separator housing. Air leaks may occur if O-ring is not seated.

- f. Clean the bowl assembly with a mild soap solution and cold water.
- g. Inspect the drain hoses for any kinks. Remove the drain hose inside the air dryer system and the drain hose outside the unit and blow into the

line to clear any sediment or foreign material from the lines.

- h. Reinstall the moisture separator bowl, the lower filter bracket, the particle strainer assembly, and the two drain hoses. If the separator still will not drain, contact Quincy or your distributor to order a new separator assembly.

Condenser coil cleaning - Remove ambient filter (if equipped). Remove either the right or left side panel screws and panel. Using compressed air, blow collected dust and contamination off condenser from inside to outside.

Hot gas bypass valve adjustment - The hot gas bypass valve adjustment regulates the flow of refrigerant through the heat exchanger to maintain the proper suction pressure. The suction pressure must be maintained within the proper range for normal operation. The needle on the refrigerant suction pressure gauge should be in the blue zone.

- a. Hot gas bypass valve adjustments must be made while the unit is operating. **DO NOT TURN THE UNIT OFF.**
- b. Remove the left side panel on the cabinet. The hot gas bypass valve adjustment nut is located on the refrigerant discharge line near the compressor.
- c. If the suction pressure gauge indicator arrow is below 25 PSIG, turn the adjusting nut **CLOCKWISE**. If the suction pressure gauge indicator needle is above 33 PSIG, turn the adjusting nut **COUNTERCLOCKWISE**. Let the unit operate for a few minutes and read the suction pressure gauge again. Continue to adjust the valve until the indicator arrow is in the **BLUE ZONE** between 25 PSIG and 33 PSIG. Adjust only 1/4 of a turn at a time. **ALLOW 4 — 5 MINUTES BETWEEN ADJUSTMENTS.**

High Temperature Refrigerated Air Dryers

Troubleshooting

SYMPTOMS	CAUSE	REMEDY
MOISTURE DOWNSTREAM	REFRIGERATION COMPRESSOR NOT RUNNING SUCTION PRESSURE READS ABOVE THE BLUE ZONE MOISTURE SEPARATOR AUTO DRAIN MALFUNCTION	CHECK ELECTRIC POWER SUPPLY. IF RED LIGHT IS ON, CALL FOR FACTORY SERVICE. CLEAN THE AIR COOLED CONDENSER (SEE PAGE 12). ADJUST HOT GAS BYPASS VALVE (SEE PAGE 12). CHECK FOR DEFECTIVE FAN MOTOR AND REPLACE. CHECK THE AUTO DRAIN OPERATION (SEE PAGE 11). CHECK FOR CLOGGED DRAIN LINE FROM AUTO DRAIN OUTLET TO FLOOR DRAIN. CHECK THE ELECTRONIC TIMER FOR LOOSE WIRES OR EVIDENCE OF BURN OUT.
OIL DOWNSTREAM (ONLY APPLIES WITH OIL FILTER OPTION)	OIL FILTER MALFUNCTION FILTER ELEMENT DIRTY	CHECK THE DRAIN OPERATION. CLEAN THE DRAIN IF STUCK OR CLOGGED. CHECK THE DRAIN MANUAL VALVE FOR CLOGGING. REPLACE ELEMENT (SEE PAGE 11).
LOW AIR PRESSURE DOWNSTREAM	SUCTION PRESSURE BELOW THE BLUE ZONE. THIS CAUSES FREEZE-UP IN THE AIR SYSTEMS	ADJUST HOT GAS BYPASS VALVE (SEE PAGE 12). LOW ON REFRIGERANT. CALL FOR SERVICE. TO CONFIRM FREEZE-UP, SHUT OFF THE UNIT FOR 15 MINUTES. AIR PRESSURE SHOULD COME BACK TO LINE PRESSURE.
CONTINUOUS AIR FLOW THROUGH THE MOISTURE DRAIN LINE	FOREIGN MATERIALS LODGED ON THE VALVE SEAT SHORT-CIRCUITED TIMER BOARD SHORT-CIRCUITED PUSH-TO-TEST SWITCH DEFECTIVE SOLENOID VALVE	PRESS THE PUSH-TO-TEST SWITCH SEVERAL TIMES. DISCONNECT THE DRAIN LINES TO THE SOLENOID VALVE AND BLOW COMPRESSED AIR FROM OUTLET WHILE PRESSING THE PUSH-TO-TEST SWITCH. REPLACE. REPLACE. REPLACE.
MOISTURE IS NOT DRAINING	CLOGGED SOLENOID VALVE DEFECTIVE TIMER BOARD DEFECTIVE SOLENOID VALVE CLOGGED DRAIN LINES	PRESS THE PUSH-TO-TEST SWITCH SEVERAL TIMES. DISCONNECT THE DRAIN LINES TO THE SOLENOID VALVE AND BLOW COMPRESSED AIR FROM OUTLET WHILE PRESSING THE PUSH-TO-TEST SWITCH. REPLACE. REPLACE. CLEAN OR REPLACE.
OPTIONAL OIL FILTER NOT DRAINING. (OIL LEVEL SEEN ABOVE HALF WAY POINT THROUGH THE BOWL SIGHT GLASS.)	DEFECTIVE DRAIN VALVE PLUGGED DRAIN VALVE	REPLACE. CLEAN IN SOAP AND WATER OR REPLACE.

High Temperature Refrigerated Air Dryers

QPHT 25 Parts Lists

115V/1PH/60Hz		
PART DESCRIPTION	PART NO.	QTY.
REFRIGERANT CONDENSING UNIT 0.25 HP R-134A	QRF-001015	1
FAN MOTOR	QRF-001280	1
FAN BLADE	QRF-000538	1
RECEIVER	QRF-003224	1
CAPILLARY TUBE ASSEMBLY	QRF-001182	1
HOT GAS BYPASS VALVE	QVA-000579	1
POWER ON/OFF SWITCH	QRF-001983	1
SUCTION PRESSURE GAUGE	QGM-000318	1
DRAIN VALVE 2-WAY SOLENOID VALVE 0.375"	QVA-003757	1
DRAIN TIMER	QEC-000486	1
Y-STRAINER 0.375"	QRF-001210	1
Y-STRAINER SCREEN	QFT-003845	1
AMBIENT FILTER (OPTIONAL)	QRF-000811	2
COALESCING FILTER ELEMENT (OPTIONAL)	CSNE00030	1

230V/1PH/60Hz		
PART DESCRIPTION	PART NO.	QTY.
REFRIGERANT CONDENSING UNIT .25 HP R-134A	QRF-001226	1
FAN MOTOR	QRF-001277	1
FAN BLADE	QRF-000538	1
RECEIVER	QRF-003224	1
CAPILLARY TUBE ASSEMBLY	QRF-001182	1
HOT GAS BYPASS VALVE	QVA-000579	1
POWER ON/OFF SWITCH	QRF-001983	1
SUCTION PRESSURE GAUGE	QGM-000318	1
DRAIN VALVE 2-WAY SOLENOID VALVE 0.375"	QVA-000689	1
DRAIN TIMER	QEC-001040	1
Y-STRAINER 0.375"	QRF-001210	1
Y-STRAINER SCREEN	QFT-003845	1
AMBIENT FILTER (OPTIONAL)	QRF-000811	2
COALESCING FILTER ELEMENT (OPTIONAL)	CSNE00030	1

High Temperature Refrigerated Air Dryers

QPHT 50 Parts Lists

115V/1PH/60Hz		
PART DESCRIPTION	PART NO.	QTY.
REFRIGERANT COMPRESSOR 0.33 HP R-134A	QRF-004039	1
FAN MOTOR	QRF-000794	1
FAN BLADE	QRF-000774	1
RECEIVER	QRF-003224	1
EXPANSION VALVE	QVA-001784	1
HOT GAS BYPASS VALVE	QVA-000579	1
POWER ON/OFF SWITCH	QRF-001983	1
SUCTION PRESSURE GAUGE	QGM-000318	1
DRAIN VALVE 2-WAY SOLENOID VALVE 0.375"	QVA-003757	1
DRAIN TIMER	QEC-000486	1
Y-STRAINER 0.375"	QRF-001210	1
Y-STRAINER SCREEN	QFT-003845	1
AMBIENT FILTER (OPTIONAL)	QRF-002641	2
COALESCING FILTER ELEMENT (OPTIONAL)	CSNE00060	1

230V/1PH/60Hz		
PART DESCRIPTION	PART NO.	QTY.
REFRIGERANT COMPRESSOR 0.33 HP R-134A	1624 5007 31	1
FAN MOTOR	QRF-000795	1
FAN BLADE	QRF-000774	1
RECEIVER	QRF-003224	1
EXPANSION VALVE	QVA-001784	1
HOT GAS BYPASS VALVE	QVA-000579	1
POWER ON/OFF SWITCH	QRF-001983	1
SUCTION PRESSURE GAUGE	QGM-000318	1
DRAIN VALVE 2-WAY SOLENOID VALVE 0.375"	QVA-000689	1
DRAIN TIMER	QEC-001040	1
Y-STRAINER 0.375"	QRF-001210	1
Y-STRAINER SCREEN	QFT-003845	1
AMBIENT FILTER (OPTIONAL)	QRF-002641	2
COALESCING FILTER ELEMENT (OPTIONAL)	CSNE00060	1

High Temperature Refrigerated Air Dryers

QPHT 75 Parts Lists

115V/1PH/60Hz		
PART DESCRIPTION	PART NO.	QTY.
REFRIGERANT COMPRESSOR 0.5 HP R-134A	QRF-003108	1
FAN MOTOR	QRF-000794	1
FAN BLADE	QRF-000774	1
RECEIVER	QRF-003224	1
EXPANSION VALVE	QVA-001783	1
HOT GAS BYPASS VALVE	QVA-000579	1
FAN CYCLING SWITCH	QRF-002079	1
POWER ON/OFF SWITCH	QRF-001983	1
SUCTION PRESSURE GAUGE	QGM-000318	1
DRAIN VALVE 2-WAY SOLENOID VALVE 0.375"	QVA-003757	1
DRAIN TIMER	QEC-000486	1
Y-STRAINER 0.375"	QRF-001210	1
Y-STRAINER SCREEN	QFT-003845	1
AMBIENT FILTER (OPTIONAL)	QRF-002641	2
COALESCING FILTER ELEMENT (OPTIONAL)	CSNE00060	1

230V/1PH/60Hz		
PART DESCRIPTION	PART NO.	QTY.
REFRIGERANT COMPRESSOR 0.5 HP R-134A	QRF-003110	1
FAN MOTOR	QRF-000795	1
FAN BLADE	QRF-000774	1
RECEIVER	QRF-003224	1
EXPANSION VALVE	QVA-001783	1
HOT GAS BYPASS VALVE	QVA-000579	1
FAN CYCLING SWITCH	QRF-002079	1
POWER ON/OFF SWITCH	QRF-001983	1
SUCTION PRESSURE GAUGE	QGM-000318	1
DRAIN VALVE 2-WAY SOLENOID VALVE 0.375"	QVA-000689	1
DRAIN TIMER	QEC-001040	1
Y-STRAINER 0.375"	QRF-001210	1
Y-STRAINER SCREEN	QFT-003845	1
AMBIENT FILTER (OPTIONAL)	QRF-002641	2
COALESCING FILTER ELEMENT (OPTIONAL)	CSNE00060	1

High Temperature Refrigerated Air Dryers

QPHT 100 Parts Lists

115V/1PH/60Hz		
PART DESCRIPTION	PART NO.	QTY.
REFRIGERANT COMPRESSOR 0.75 HP R-134A	QRF-003109	1
FAN MOTOR	QRF-000794	1
FAN BLADE	QRF-000774	1
RECEIVER	QRF-003224	1
EXPANSION VALVE	QVA-001783	1
HOT GAS BYPASS VALVE	QVA-000579	1
FAN CYCLING SWITCH	QRF-002079	1
POWER ON/OFF SWITCH	QRF-001983	1
SUCTION PRESSURE GAUGE	QGM-000318	1
DRAIN VALVE 2-WAY SOLENOID VALVE 0.375"	QVA-003757	1
DRAIN TIMER	QEC-000486	1
Y-STRAINER 0.375"	QRF-001210	1
Y-STRAINER SCREEN	QFT-003845	1
AMBIENT FILTER (OPTIONAL)	QRF-002641	2
COALESCING FILTER ELEMENT (OPTIONAL)	CSNE00125	1

230V/1PH/60Hz		
PART DESCRIPTION	PART NO.	QTY.
REFRIGERANT COMPRESSOR 0.5 HP R-134A	QRF-003111	1
FAN MOTOR	QRF-000795	1
FAN BLADE	QRF-000774	1
RECEIVER	QRF-003224	1
EXPANSION VALVE	QVA-001783	1
HOT GAS BYPASS VALVE	QVA-000579	1
FAN CYCLING SWITCH	QRF-002079	1
POWER ON/OFF SWITCH	QRF-001983	1
SUCTION PRESSURE GAUGE	QGM-000318	1
DRAIN VALVE 2-WAY SOLENOID VALVE 0.375"	QVA-000689	1
DRAIN TIMER	QEC-001040	1
Y-STRAINER 0.375"	QRF-001210	1
Y-STRAINER SCREEN	QFT-003845	1
AMBIENT FILTER (OPTIONAL)	QRF-002641	2
COALESCING FILTER ELEMENT (OPTIONAL)	CSNE00125	1

High Temperature Refrigerated Air Dryers

QPHT 125 Parts Lists

115V/1PH/60Hz		
PART DESCRIPTION	PART NO.	QTY.
REFRIGERANT COMPRESSOR 0.75 HP R-134A	QRF-003109	1
FAN MOTOR	QRF-000794	1
FAN BLADE	QRF-000774	1
RECEIVER	QRF-003224	1
EXPANSION VALVE	QVA-001783	1
HOT GAS BYPASS VALVE	QVA-000579	1
FAN CYCLING SWITCH	QRF-002079	1
POWER ON/OFF SWITCH	QRF-001983	1
SUCTION PRESSURE GAUGE	QGM-000318	1
DRAIN VALVE 2-WAY SOLENOID VALVE 0.375"	QVA-003757	1
DRAIN TIMER	QEC-000486	1
Y-STRAINER 0.375"	QRF-001210	1
Y-STRAINER SCREEN	QFT-003845	1
AMBIENT FILTER (OPTIONAL)	QRF-002641	2
COALESCING FILTER ELEMENT (OPTIONAL)	CSNE00125	1

230V/1PH/60Hz		
PART DESCRIPTION	PART NO.	QTY.
REFRIGERANT COMPRESSOR 0.5 HP R-134A	QRF-003111	1
FAN MOTOR	QRF-000795	1
FAN BLADE	QRF-000774	1
RECEIVER	QRF-003224	1
EXPANSION VALVE	QVA-001783	1
HOT GAS BYPASS VALVE	QVA-000579	1
FAN CYCLING SWITCH	QRF-002079	1
POWER ON/OFF SWITCH	QRF-001983	1
SUCTION PRESSURE GAUGE	QGM-000318	1
DRAIN VALVE 2-WAY SOLENOID VALVE 0.375"	QVA-000689	1
DRAIN TIMER	QEC-001040	1
Y-STRAINER 0.375"	QRF-001210	1
Y-STRAINER SCREEN	QFT-003845	1
AMBIENT FILTER (OPTIONAL)	QRF-002641	2
COALESCING FILTER ELEMENT (OPTIONAL)	CSNE00125	1

High Temperature Refrigerated Air Dryers

QPHT 25 Dimensional

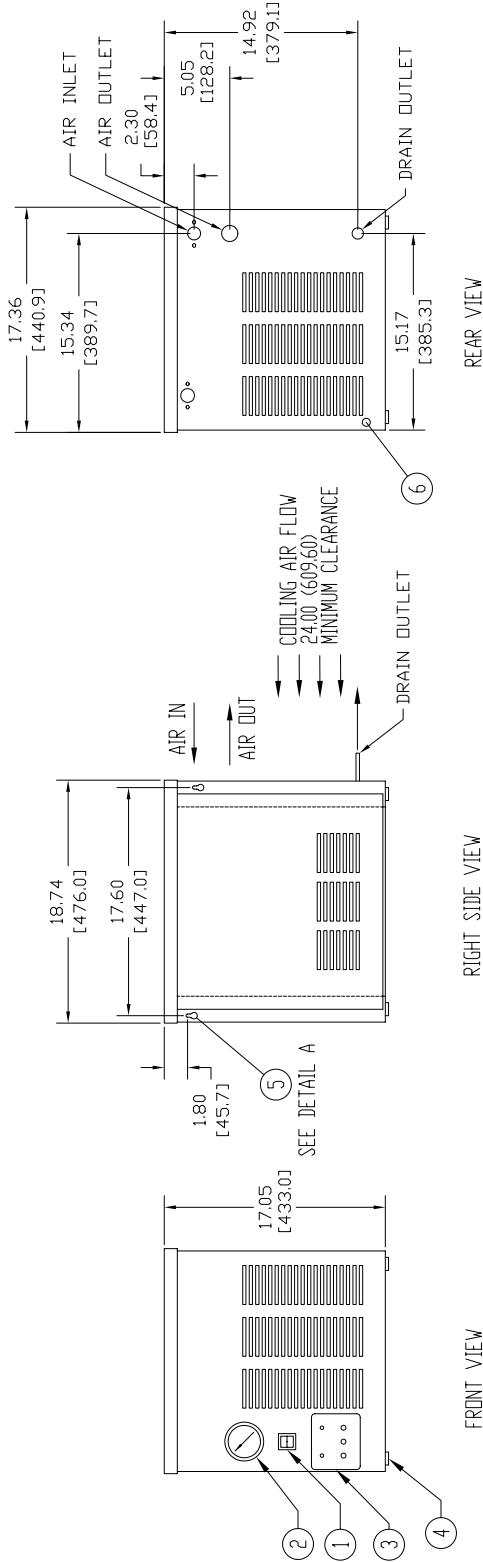

OPERATING CONDITIONS:

- CAPACITY: 25 SCFM (42 NM3/HR)
- MAX. INLET TEMP: 180°F (82°C)
- MAX. AMBIENT TEMP: 100°F (38°C)
- MIN. AMBIENT TEMP: 40°F (4°C)
- INLET PRESSURE: 175 PSIG (12.3 KG/SQ.CM)
- MAX. PRESSURE: 200 PSIG (14.1 KG/SQ.CM)
- OUTLET TEMP: 50°F±2° (10°C±1)
- REFRIGERANT HP: 1/4
- ELECTRICAL POWER: 115V-1PH-60HZ or 110V-1PH-50HZ or 230V-1PH-60HZ or 220V-1PH-50HZ
- AIR CONNECTIONS: 1/2" NPT (F)
- DRAIN LINE: 1/4" O.D. PLASTIC TUBING
- REFRIGERANT: R-134a
- AUTOMATIC DRAIN: ELECTRONIC
- WEIGHT: 86 LBS (39KG)

STANDARD ACCESSORIES:

1. POWER ON/OFF SWITCH
2. HIGH TEMPERATURE LIGHT
3. REFRIGERANT SUCTION PRESSURE GAUGE
4. ELECTRONIC DRAIN VALVE CONTROLS
5. RUBBER MOUNTS (4X)
6. ELECTRICAL SUPPLY CORD 6.0' (1829mm)

OPTIONAL ACCESSORIES:

- A - LOW AMBIENT HEADMASTER CONTROL
 - B - AMBIENT FILTERS
- ALL DIMENSIONS ARE IN INCHES (MILLIMETERS)
GENERAL TOLERANCE: 1/8" (3.2mm)

High Temperature Refrigerated Air Dryers

QPHT 50 Dimensional

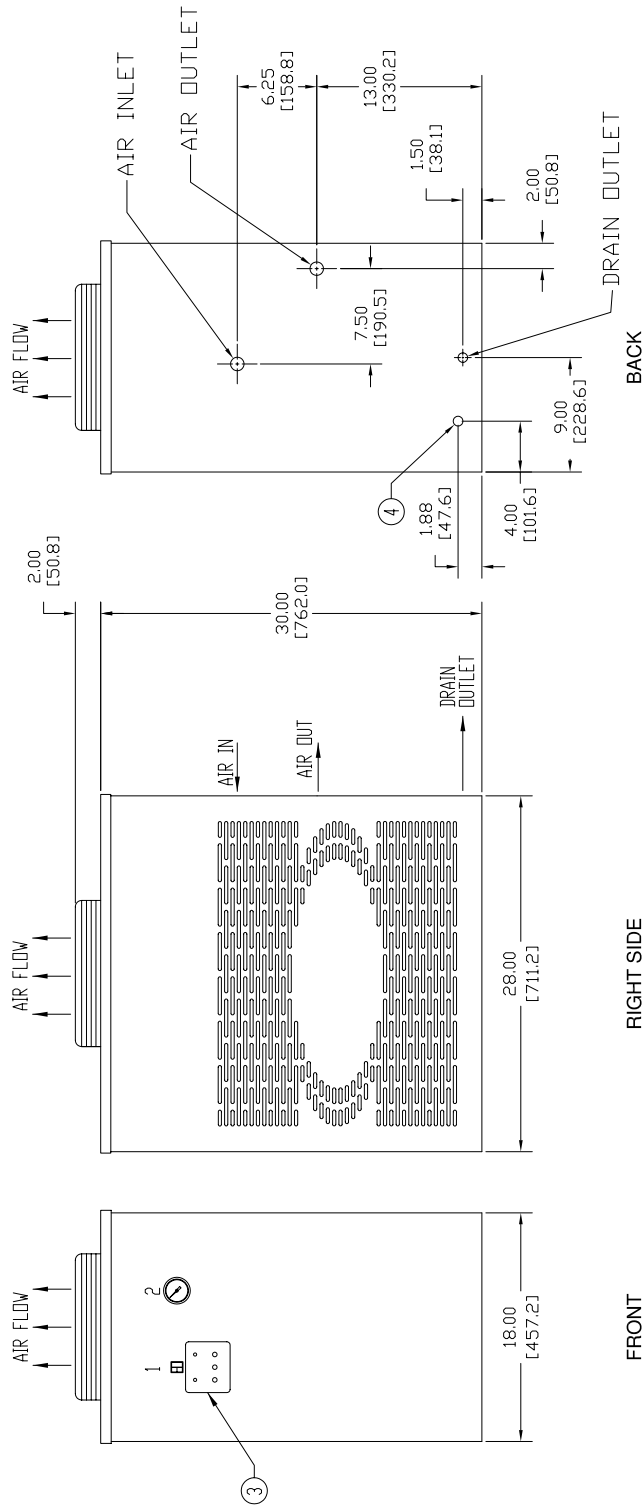

STANDARD ACCESSORIES

- 1 - POWER ON / OFF SWITCH
- POWER ON LIGHT
- HIGH TEMPERATURE LIGHT
- 2 - REFRIGERANT SUCTION PRESSURE GAUGE
- 3 - ELECTRONIC DRAIN VALVE CONTROLS
- 4 - ELECTRICAL SUPPLY CORD - 6' (1829mm)

OPTIONAL ACCESSORY

- A - LOW AMBIENT HEADMASTER CONTROL

ALL DIMENSIONS ARE IN INCHES (MILLIMETERS)
GENERAL TOLERANCE: 1/8" (3.2mm)

OPERATING CONDITIONS

- CAPACITY: 50 SCFM (85 NM3/HR)
- MAX. INLET TEMPERATURE: 180°F (82°C)
- MAX. AMBIENT TEMPERATURE: 100°F (38°C)
- MIN. AMBIENT TEMPERATURE: 40°F (4°C)
- INLET PRESSURE: 175 PSIG (12.3 KG/SQ.CM)
- MAX. PRESSURE: 200 PSIG (14.06 KG/SQ.CM)
- OUTLET TEMPERATURE: 50 ± 2°F (10 ± 1°C)
- REFRIGERATION HP: 1/2
- ELECTRICAL POWER: 115V-1PH-60HZ or 230V-1PH-60HZ or 230V-1PH-50HZ

- AIR CONNECTIONS: 1/2" NPT
- DRAIN LINE: 3/8" NPT
- REFRIGERANT: R-134a
- AUTOMATIC DRAIN: 135 LBS (61 KGS)
- WEIGHT: 135 LBS (61 KGS)

High Temperature Refrigerated Air Dryers

QPHT 75/100/125 Dimensional

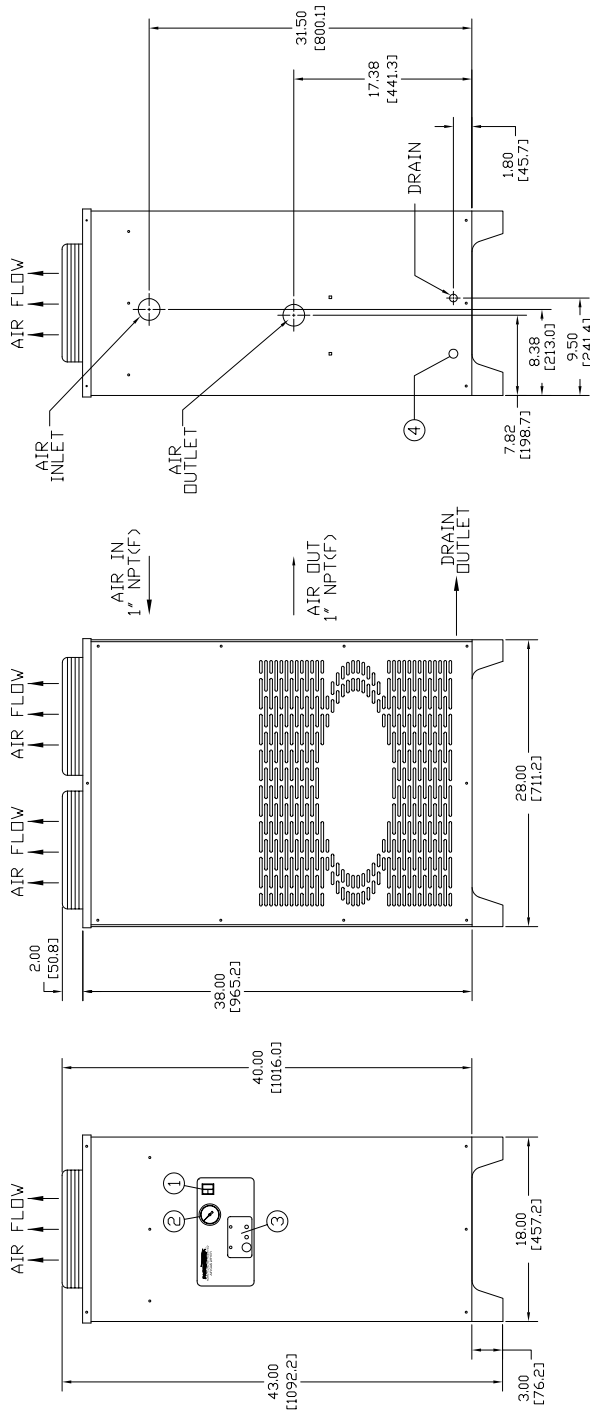

BACK

RIGHT SIDE

FRONT

OPERATING CONDITIONS

MAX. INLET TEMPERATURE: 180°F (82°C)
 MAX. AMBIENT TEMPERATURE: 100°F (38°C)
 MIN. AMBIENT TEMPERATURE: 40°F (4°C)
 DESIGN PRESSURE: 200 PSIG (14.1 KG/SQ.CM)
 INLET PRESSURE: 175 PSIG (12.3 KG/SQ.CM)
 DRY POINT TEMPERATURE: 50 ± 2°F (10 ± 1°C)
 AIR CONNECTIONS: 1" NPT
 REFRIGERANT: R-134a
 AUTOMATIC DRAIN: ELECTRONIC
 DRAIN LINE: 3/8" NPT

STANDARD ACCESSORIES

- 1 - POWER ON / OFF SWITCH
- POWER ON LIGHT
- HIGH TEMPERATURE LIGHT
- 2 - REFRIGERANT SUCTION PRESSURE GAUGE
- 3 - ELECTRONIC DRAIN VALVE CONTROLS
- 4 - ELECTRICAL SUPPLY CORD - 6' (1829mm)

OPTIONAL ACCESSORY

- A - LOW AMBIENT HEADMASTER CONTROL

MODEL	CAPACITY	HP	ELECTRIC POWER SUPPLY	APPROX. WEIGHT	
				LBS.	KG
QPHT-75	75 SCFM (127 NM ³ /HR)	1/2	115V-1PH-60HZ or 110V-1PH-50HZ	186	84
QPHT-75	75 SCFM (127 NM ³ /HR)	1/2	230V-1PH-60HZ or 220V-1PH-50HZ	186	84
QPHT-100	100 SCFM (170 NM ³ /HR)	3/4	115V-1PH-60HZ or 110V-1PH-50HZ	232	105
QPHT-100	100 SCFM (170 NM ³ /HR)	3/4	230V-1PH-60HZ or 220V-1PH-50HZ	232	105
QPHT-125	125 SCFM (212 NM ³ /HR)	3/4	115V-1PH-60HZ or 110V-1PH-50HZ	244	111
QPHT-125	125 SCFM (212 NM ³ /HR)	3/4	230V-1PH-60HZ or 220V-1PH-50HZ	244	111

QPHT 25 Wiring Diagram

ITEM	DESCRIPTION	STD.	DPT.
SW	POWER ON/OFF SWITCH		
L1	POWER ON LIGHT (AMBER)		
L2	HIGH TEMPERATURE LIGHT (RED)		
SOL1	DRAIN SOLENOID VALVE		
CR	CURRENT RELAY		
DL	OVERLOAD		
FM	FAN MOTOR		
PC	FAN MOTOR		
G	POWER GROUND		
TM	SOLID STATE TIMER		
	INTERNALLY WIRED COMPONENTS:		
L3	DRAIN POWER LIGHT (GREEN)		
L4	DRAIN ON LIGHT (RED)		
DT	DRAIN TIME ADJUSTMENT KNOB		
CT	CYCLE TIME ADJUSTMENT KNOB		
PTS	PUSH TO TEST SWITCH		

STD: STANDARD DPT: OPTIONAL

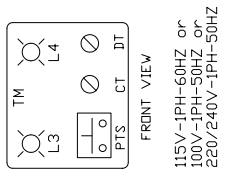
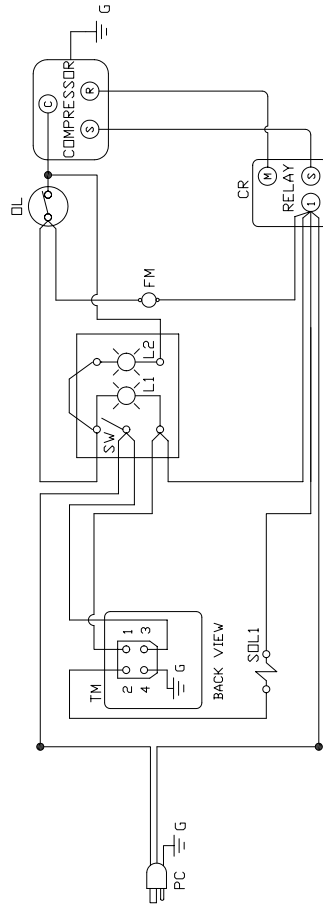

- NOTES:
- CAUTION: ELECTRIC SHOCK HAZARD. DISCONNECT THE REMOTE ELECTRIC POWER SUPPLY OR SUPPLIES BEFORE SERVICING.
 - MAIN DISCONNECT & BRANCH CIRCUIT PROTECTION IS TO BE PROVIDED BY OTHERS. SIZE IN ACCORDANCE TO LOCAL AND NEC CODE(S).
 - CAUTION: USE TIME DELAY FUSES.
 - USE COPPER, 75°C (167°F) WIRE INSULATION FOR FIELD WIRING.
 - CUSTOMER POWER SUPPLY MUST MATCH DRYER NAMEPLATE VOLTAGE, PHASE, AND FREQUENCY.
 - COMPRESSOR IS PROTECTED WITH INTERNAL OVERLOAD WHICH RESETS AFTER 15 MINUTES.
 - TURBOUE SCREWS TO 20 IN. LBS.

POWER SUPPLY	REFRIGERATION COMPRESSOR		FAN MOTOR		MAXIMUM DISCONNECT FUSE	MCA
	HP	RLA	HP	RLA		
115V-1PH-60HZ	1/4	5.4	6	0.50	15 AMP.	7.3
100V-1PH-50HZ	1/4	2.4	6	0.19	15 AMP.	3.2

MCA = MINIMUM CIRCUIT AMPACITY

NEMA CLASS: 1

ITEM	DESCRIPTION	STD.	DPT.
SW	POWER ON/OFF SWITCH		
L1	POWER ON LIGHT (AMBER)		
L2	HIGH TEMPERATURE LIGHT (RED)		
SOL1	DRAIN SOLENOID VALVE		
CR	CURRENT RELAY		
DL	OVERLOAD		
FM	FAN MOTOR		
PC	FAN MOTOR		
G	POWER GROUND		
TM	SOLID STATE TIMER		
	INTERNALLY WIRED COMPONENTS:		
L3	DRAIN POWER LIGHT (GREEN)		
L4	DRAIN ON LIGHT (RED)		
DT	DRAIN TIME ADJUSTMENT KNOB		
CT	CYCLE TIME ADJUSTMENT KNOB		
PTS	PUSH TO TEST SWITCH		

STD: STANDARD DPT: OPTIONAL

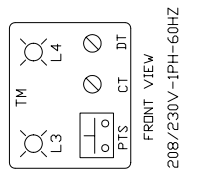
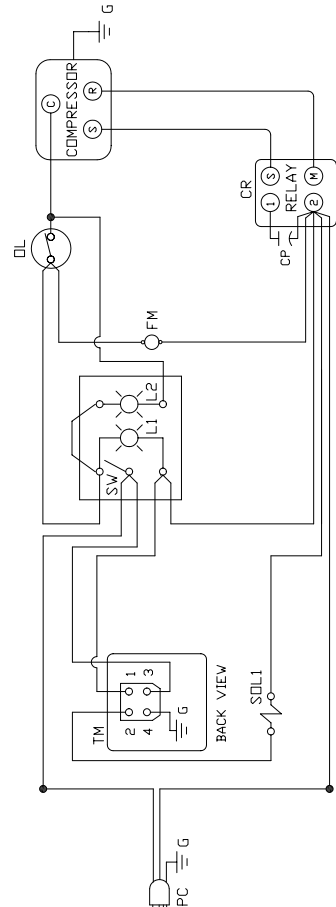

- NOTES:
- CAUTION: ELECTRIC SHOCK HAZARD. DISCONNECT THE REMOTE ELECTRIC POWER SUPPLY OR SUPPLIES BEFORE SERVICING.
 - MAIN DISCONNECT & BRANCH CIRCUIT PROTECTION IS TO BE PROVIDED BY OTHERS. SIZE IN ACCORDANCE TO LOCAL AND NEC CODE(S).
 - CAUTION: USE TIME DELAY FUSES.
 - USE COPPER, 75°C (167°F) WIRE INSULATION FOR FIELD WIRING.
 - CUSTOMER POWER SUPPLY MUST MATCH DRYER NAMEPLATE VOLTAGE, PHASE, AND FREQUENCY.
 - COMPRESSOR IS PROTECTED WITH INTERNAL OVERLOAD WHICH RESETS AFTER 15 MINUTES.
 - TURBOUE SCREWS TO 20 IN. LBS.

POWER SUPPLY	REFRIGERATION COMPRESSOR		FAN MOTOR		MAXIMUM DISCONNECT FUSE	MCA
	HP	RLA	HP	RLA		
208/230V-1PH-60HZ	1/4	2.8	14.4	0.19	15 AMP.	3.7

MCA = MINIMUM CIRCUIT AMPACITY

NEMA CLASS: 1

High Temperature Refrigerated Air Dryers

QPHT 50 Wiring Diagram

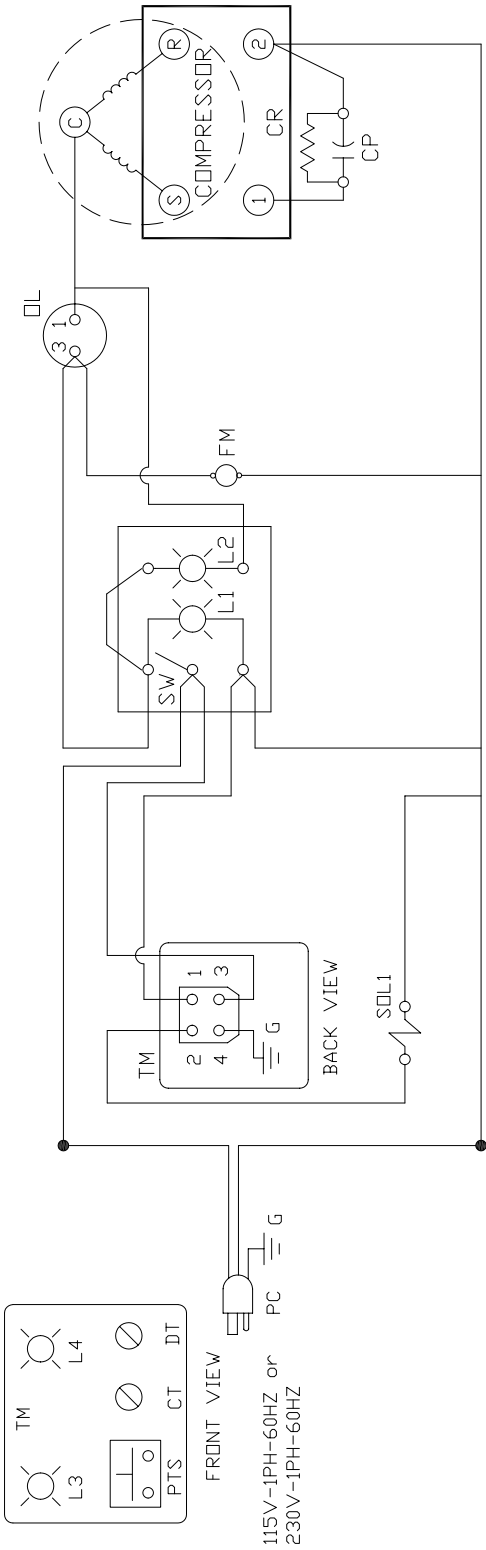

- NOTES:**
1. CAUTION: ELECTRIC SHOCK HAZARD. DISCONNECT THE REMOTE ELECTRIC POWER SUPPLY OR SUPPLIES BEFORE SERVICING.
 2. MAIN DISCONNECT & BRANCH CIRCUIT PROTECTION IS TO BE PROVIDED BY OTHERS. SIZE IN ACCORDANCE TO LOCAL AND NEC CODE(S).
 3. CAUTION: USE TIME DELAY FUSES.
 4. USE COPPER, 75°C (167°F) WIRE INSULATION FOR FIELD WIRING.
 5. CUSTOMER POWER SUPPLY MUST MATCH DRYER NAMEPLATE VOLTAGE.
 6. COMPRESSOR IS PROTECTED WITH INTERNAL OVERLOAD WHICH RESETS AUTOMATICALLY.
 7. TORQUE SCREWS TO 20 IN LBS.

ITEM	DESCRIPTION	
SW	POWER ON/OFF SWITCH	STD.
L1	POWER ON LIGHT (AMBER)	STD.
L2	HIGH TEMPERATURE LIGHT (RED)	STD.
SOL1	DRAIN SOLENOID VALVE	STD.
CR	CURRENT RELAY	STD.
CP	START CAPACITOR	STD.
DL	OVERLOAD	STD.
FM	FAN MOTOR	STD.
PC	POWER CORD	STD.
G	GROUND	STD.
TM	SOLID STATE TIMER	STD.
	INTERNALLY WIRED COMPONENTS:	
L3	DRAIN POWER LIGHT (GREEN)	
L4	DRAIN ON LIGHT (RED)	
DT	DRAIN TIME ADJUSTMENT KNOB	
CT	CYCLE TIME ADJUSTMENT KNOB	
PTS	PUSH TO TEST SWITCH	

STD: STANDARD OPT: OPTIONAL

POWER SUPPLY	REFRIGERATION COMPRESSOR		FAN MOTOR		MAXIMUM DISCONNECT FUSE	MCA		
	HP	RLA	LRA	HP			RLA	
115V-1PH-60HZ	R-134a	1/3	7.1	37.5	16 WATT	.8	15 AMP.	9.7
230V-1PH-60HZ	R-134a	1/3	3.9	23.8	16 WATT	.4	15 AMP.	5.3
220V-1PH-50HZ	R-134a	1/3	3.9	17.4	16 WATT	.4	15 AMP.	5.3

NEMA CLASS: 1 MCA = MINIMUM CIRCUIT AMPACITY

115V-1PH-60HZ EMBRACO NE6210Z1 COMPRESSOR
 230V-1PH-60HZ EMBRACO NE6210Z2 COMPRESSOR
 220V-1PH-50HZ EMBRACO NE6210Z3 COMPRESSOR

High Temperature Refrigerated Air Dryers

QPHT 75 (115V) Wiring Diagram

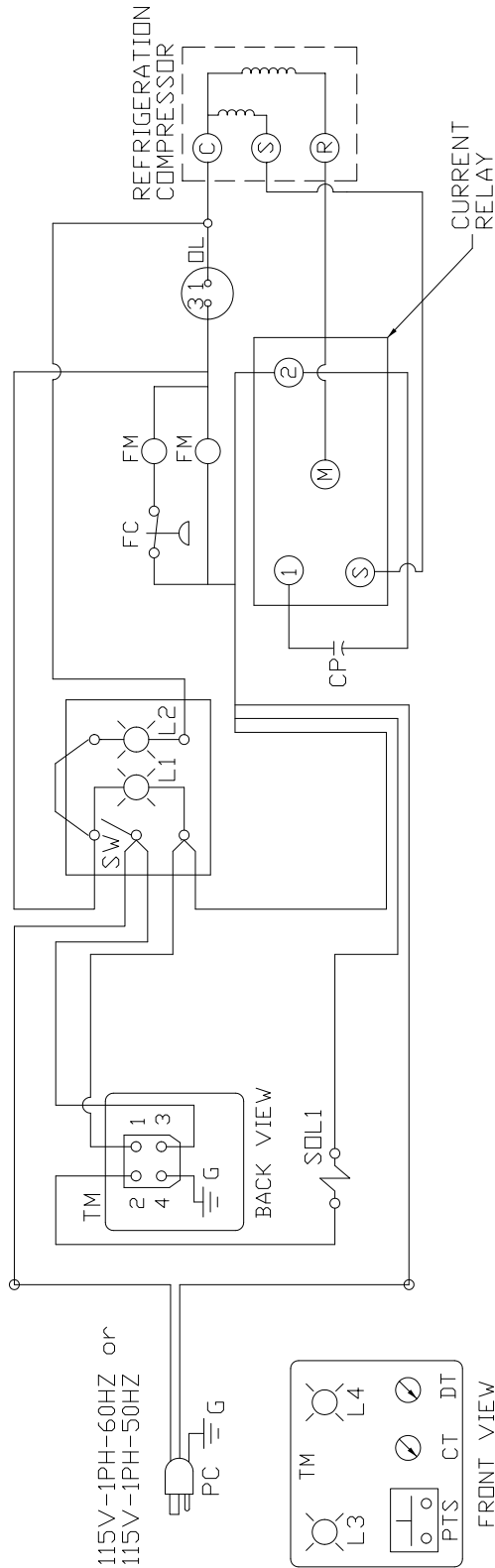

ITEM	DESCRIPTION	STD.
SW	POWER ON/OFF SWITCH	STD.
L1	POWER ON LIGHT (AMBER)	STD.
L2	HIGH TEMPERATURE LIGHT (RED)	STD.
SOL1	DRAIN SOLENOID VALVE	STD.
CP	START CAPACITOR	STD.
OL	OVERLOAD	STD.
FM	FAN MOTOR	STD.
PC	POWER CORD (14 GAUGE)	STD.
FC	CYCLING FAN CONTROL	OPT.
G	GROUND	STD.
TM	SOLID STATE TIMER INTERNALLY WIRED COMPONENTS:	STD.
L3	DRAIN POWER LIGHT (GREEN)	
L4	DRAIN ON LIGHT (RED)	
DT	DRAIN TIME ADJUSTMENT KNOB	
CT	CYCLE TIME ADJUSTMENT KNOB	
PTS	PUSH TO TEST SWITCH	

- NOTES:**
- CAUTION: ELECTRIC SHOCK HAZARD. DISCONNECT THE REMOTE ELECTRIC POWER SUPPLY OR SUPPLIES BEFORE SERVICING.
 - MAIN DISCONNECT & BRANCH CIRCUIT PROTECTION IS TO BE PROVIDED BY OTHERS. SIZE IN ACCORDANCE TO LOCAL AND NEC CODE(S).
 - CAUTION: USE TIME DELAY FUSES.
 - USE COPPER, 75°C (167°F) WIRE INSULATION FOR FIELD WIRING.
 - CUSTOMER POWER SUPPLY MUST MATCH DRYER NAMEPLATE VOLTAGE.
 - COMPRESSOR IS PROTECTED WITH INTERNAL OVERLOAD WHICH RESETS AUTOMATICALLY.
 - TORQUE SCREWS TO 20 IN LBS.

EMBRACO T6213Z COMPRESSOR

POWER SUPPLY	REFRIGERATION COMPRESSOR		FAN MOTOR		MAXIMUM DISCONNECT FUSE	MINIMUM CIRCUIT AMPACITY
	HP	RLA	LRA	HP		
115V-1PH-60HZ 115V-1PH-50HZ	R-134a	1/2	9.3	36	(2) 16 WATT EA. EA.	13.6

NEMA CLASS: 1

High Temperature Refrigerated Air Dryers

QPHT 75 (230V) Wiring Diagram

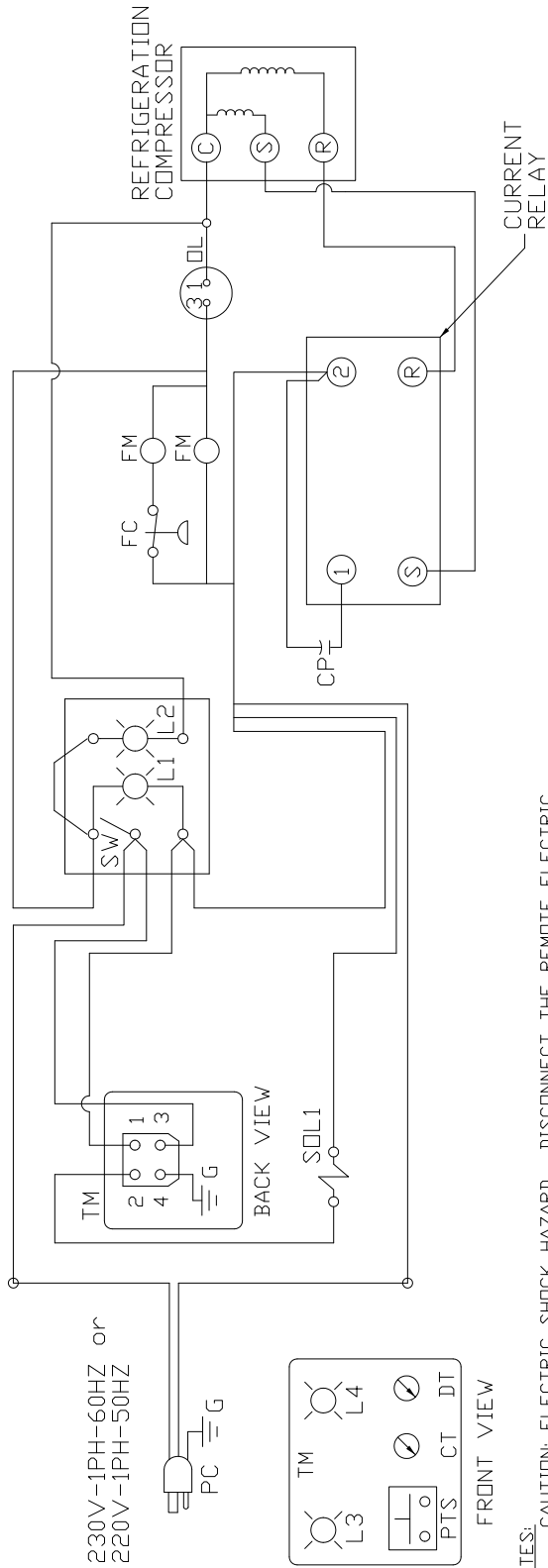

NOTES:

1. CAUTION: ELECTRIC SHOCK HAZARD. DISCONNECT THE REMOTE ELECTRIC POWER SUPPLY OR SUPPLIES BEFORE SERVICING.
2. MAIN DISCONNECT & BRANCH CIRCUIT PROTECTION IS TO BE PROVIDED BY OTHERS. SIZE IN ACCORDANCE TO LOCAL AND NEC CODE(S).
3. CAUTION: USE TIME DELAY FUSES.
4. USE COPPER, 75°C (167°F) WIRE INSULATION FOR FIELD WIRING.
5. CUSTOMER POWER SUPPLY MUST MATCH DRYER NAMEPLATE VOLTAGE.
6. COMPRESSOR IS PROTECTED WITH INTERNAL OVERLOAD WHICH RESETS AUTOMATICALLY.
7. TORQUE SCREWS TO 20 IN LBS.

EMBRACO T6213Z COMPRESSOR

POWER SUPPLY	REFRIG-ERANT	REFRIGERATION COMPRESSOR			FAN MOTOR		MAXIMUM DISCONNECT FUSE	MINIMUM CIRCUIT AMPACITY
		HP	RLA	LRA	HP	RLA		
230V-1PH-60HZ	R-134a	1/2	4.7	30	(2) 16 WATT EA.	.4 EA.	15 AMP.	6.7
220V-1PH-50HZ	R-134a	1/2	3.8	20	(2) 16 WATT EA.	.4 EA.	15 AMP.	5.6

NEMA CLASS: 1

ITEM	DESCRIPTION	STD.
SW	POWER ON/OFF SWITCH	STD.
L1	POWER ON LIGHT (AMBER)	STD.
L2	HIGH TEMPERATURE LIGHT (RED)	STD.
SOL1	DRAIN SOLENOID VALVE	STD.
CP	START CAPACITOR	STD.
DL	OVERLOAD	STD.
FM	FAN MOTOR	STD.
PC	POWER CORD (14 GAUGE)	STD.
FC	CYCLING FAN CONTROL	OPT.
G	GROUND	STD.
TM	SOLID STATE TIMER INTERNALLY WIRED COMPONENTS:	STD.
L3	DRAIN POWER LIGHT (GREEN)	
L4	DRAIN ON LIGHT (RED)	
DT	DRAIN TIME ADJUSTMENT KNOB	
CT	CYCLE TIME ADJUSTMENT KNOB	
PTS	PUSH TO TEST SWITCH	

High Temperature Refrigerated Air Dryers

QPHT 100/125 (115V) Wiring Diagram

POWER SUPPLY	REFRIG-COMPRESSOR ERANT	REFRIG-COMPRESSOR HP	RLA	LRA	FAN MOTOR HP	RLA	MINIMUM CIRCUIT AMPACITY
115V-1PH-60HZ 100V-1PH-50HZ	R-134a	3/4	13.3	72.0	(2) 16	.8	30 AMP.

EMBRACO T6220Z COMPRESSOR
NEMA CLASS: 1

CR	CURRENT RELAY
RC	REFRIGERATION COMPRESSOR
SW	POWER ON/OFF SWITCH
L1	POWER ON LIGHT (AMBER)
L2	HIGH TEMPERATURE LIGHT (RED)
SOL	DRAIN SOLENOID VALVE
CP	START CAPACITOR
OL	OVERLOAD
FM1	FAN MOTOR
FM2	FAN MOTOR
PC	POWER CORD (12 GAGE)
GND	GROUND
TM	SOLID STATE TIMER
L3	DRAIN POWER LIGHT (GREEN)
L4	DRAIN ON LIGHT (RED)
DT	DRAIN TIME ADJUST KNOB
CT	CYCLE TIME ADJUST KNOB
PTS	PUSH TO TEST BUTTON
FC	CYCLING FAN CONTROL

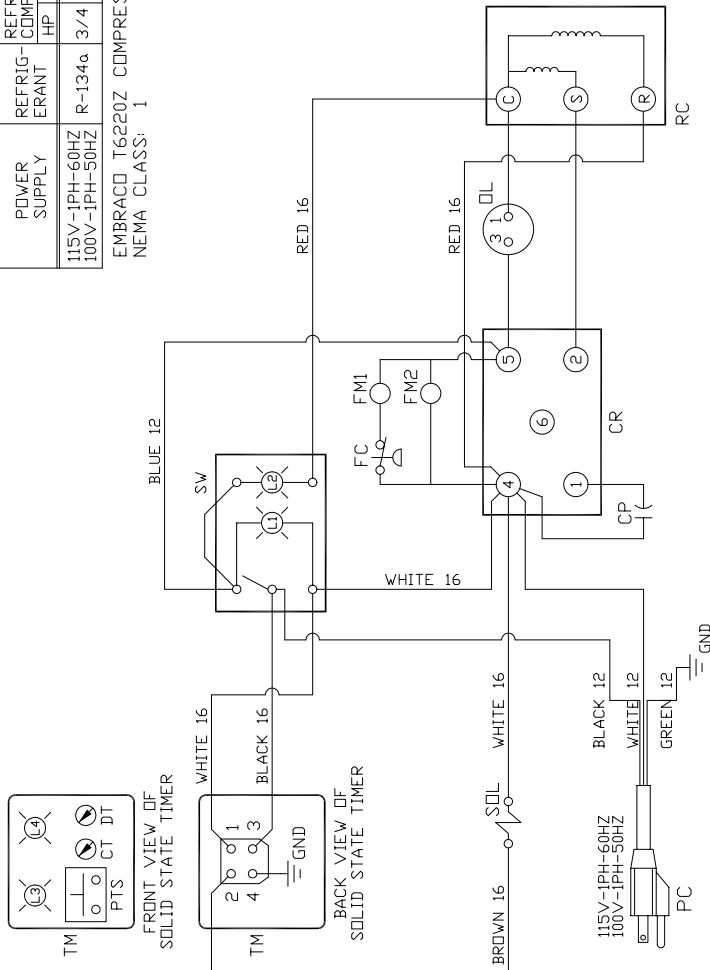

- NOTES:
1. CAUTION: ELECTRIC SHOCK HAZARD. DISCONNECT THE REMOTE ELECTRIC POWER SUPPLY OR SUPPLIES BEFORE SERVICING.
 2. MAIN DISCONNECT & BRANCH CIRCUIT PROTECTION IS TO BE PROVIDED BY OTHERS. SIZE IN ACCORDANCE TO LOCAL AND NEC CODE(S).
 3. CAUTION: USE TIME DELAY FUSES.
 4. USE COPPER, 75°C (167°F) WIRE INSULATION FOR FIELD WIRING.
 5. CUSTOMER POWER SUPPLY MUST MATCH DRYER NAMEPLATE VOLTAGE.
 6. COMPRESSOR IS PROTECTED WITH INTERNAL OVERLOAD WHICH RESETS AUTOMATICALLY.
 7. TORQUE SCREWS TO 20 IN LBS.

High Temperature Refrigerated Air Dryers

QPHT 100/125 (230V) Wiring Diagram

POWER SUPPLY	REFRIG-ERANT		REFRIGERATION COMPRESSOR		FAN MOTOR		MAXIMUM DISCONNECT FUSE	MINIMUM CIRCUIT AMPACITY
	HP	RLA	HP	RLA	HP	RLA		
230/208V-1PH-60HZ	R-134a	3/4	7.4	42.0	(2) 1/4 WATT EA.	.4 EA.	15 AMP.	10.1
220/240V-1PH-50HZ	R-134a	3/4	6.4	36.0	(2) 1/4 WATT EA.	.4 EA.	15 AMP.	8.8

EMBRACO T6220Z COMPRESSOR
NEMA CLASS: 1

CR	CURRENT RELAY
RC	REFRIGERATION COMPRESSOR
SW	POWER ON/OFF SWITCH
L1	POWER ON LIGHT (AMBER)
L2	HIGH TEMPERATURE LIGHT (RED)
SOL	DRAIN SOLENOID VALVE
CP	START CAPACITOR
DL	OVERLOAD
FM1	FAN MOTOR
FM2	FAN MOTOR
GND	GROUND
TM	SOLID STATE TIMER
L3	DRAIN POWER LIGHT (GREEN)
L4	DRAIN ON LIGHT (RED)
DT	DRAIN TIME ADJUST KNOB
CT	CYCLE TIME ADJUST KNOB
PTS	PUSH TO TEST BUTTON
FC	CYCLING FAN CONTROL

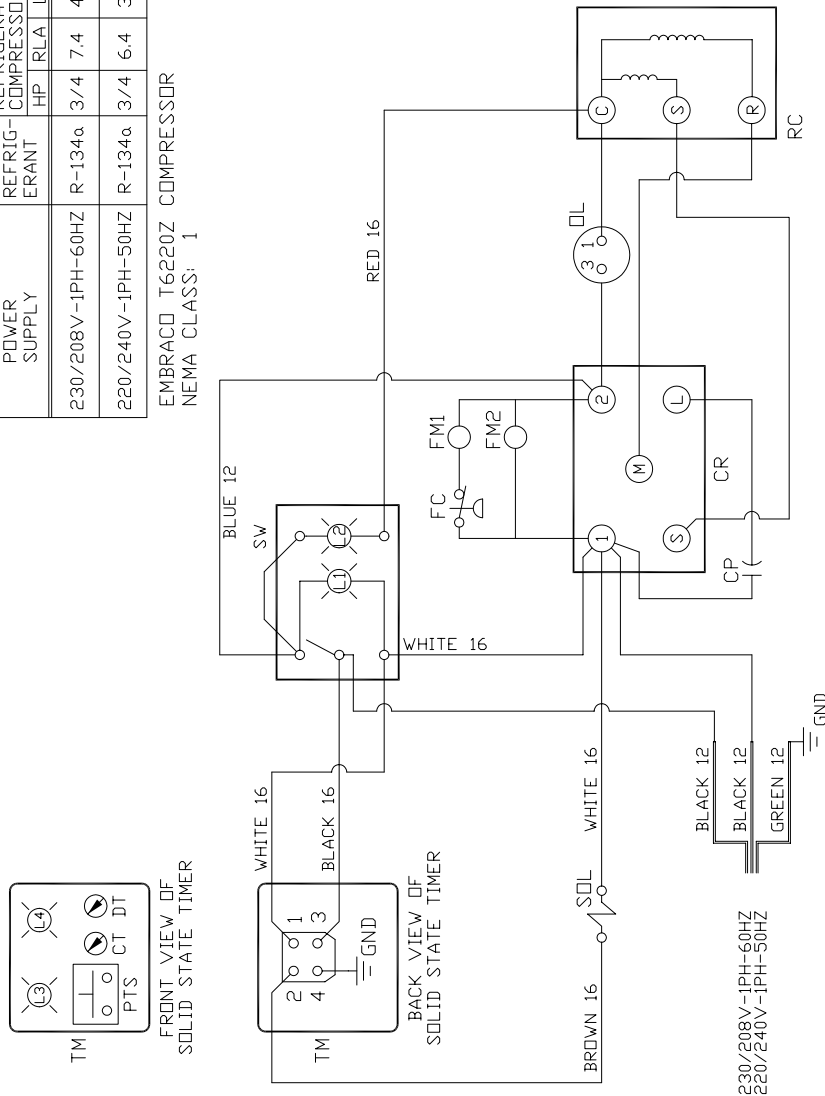

230/208V-1PH-60HZ
220/240V-1PH-50HZ

NOTES:

1. CAUTION: ELECTRIC SHOCK HAZARD. DISCONNECT THE REMOTE ELECTRIC POWER SUPPLY OR SUPPLIES BEFORE SERVICING.
2. MAIN DISCONNECT & BRANCH CIRCUIT PROTECTION IS TO BE PROVIDED BY OTHERS. SIZE IN ACCORDANCE TO LOCAL AND NEC CODE(S).
3. CAUTION: USE TIME DELAY FUSES.
4. USE COPPER, 75°C (167°F) WIRE INSULATION FOR FIELD WIRING.
5. CUSTOMER POWER SUPPLY MUST MATCH DRYER NAMEPLATE VOLTAGE.
6. COMPRESSOR IS PROTECTED WITH INTERNAL OVERLOAD WHICH RESETS AUTOMATICALLY.
7. TORQUE SCREWS TO 20 IN LBS.

STANDARD TERMS AND CONDITIONS

QUINCY COMPRESSOR AND ORTMAN FLUID POWER DIVISIONS

LEGAL EFFECT: Except as expressly otherwise agreed to in writing by an authorized representative of Seller, the following terms and conditions shall apply to and form a part of this order and any additional and/or different terms of Buyer's purchase order or other form of acceptance are rejected in advance and shall not become a part of this order.

The rights of Buyer hereunder shall be neither assignable nor transferable except with the written consent of Seller.

This order may not be canceled or altered except with the written consent of Seller and upon terms which will indemnify Seller against all loss occasioned thereby. All additional costs incurred by Seller due to changes in design or specifications, modification of this order or revision of product must be paid for by Buyer.

In addition to the rights and remedies conferred upon Seller by this order, Seller shall have all rights and remedies conferred at law and in equity and shall not be required to proceed with the performance of this order if Buyer is in default in the performance of such order or of any other contract or order with seller.

TERMS OF PAYMENT: Unless otherwise specified in the order acknowledgment, the terms of payment shall be net cash within thirty (30) days after shipment. These terms shall apply to partial as well as complete shipments. If any proceeding be initiated by or against Buyer under any bankruptcy or insolvency law, or in the judgment of Seller the financial condition of Buyer, at the time the equipment is ready for shipment, does not justify the terms of payment specified, Seller reserves the right to require full payment in cash prior to making shipment. If such payment is not received within fifteen (15) days after notification of readiness for shipment, Seller may cancel the order as to any unshipped item and require payment of its reasonable cancellation charges.

If Buyer delays shipment, payments based on date of shipment shall become due as of the date when ready for shipment. If Buyer delays completion of manufacture, Seller may elect to require payment according to percentage of completion. Equipment held for Buyer shall be at Buyer's risk and storage charges may be applied at the discretion of Seller.

Accounts past due shall bear interest at the highest rate lawful to contract for but if there is no limit set by law, such interest shall be eighteen percent (18%). Buyer shall pay all cost and expenses, including reasonable attorney's fees, incurred in collecting the same, and no claim, except claims within Seller's warranty of material or workmanship, as stated below, will be recognized unless delivered in writing to Seller within thirty (30) days after date of shipment.

TAXES: All prices exclude present and future sales, use, occupation, license, excise, and other taxes in respect of manufacture, sales or delivery, all of which shall be paid by Buyer unless included in the purchase price at the proper rate or a proper exemption certificate is furnished.

ACCEPTANCE: All offers to purchase, quotations and contracts of sales are subject to final acceptance by an authorized representative at Seller's plant.

DELIVERY: Except as otherwise specified in this quotation, delivery will be F. O. B. point of shipment. In the absence of exact shipping instruction, Seller will use its discretion regarding best means of insured shipment. No liability will be accepted by Seller for so doing. All transportation charges are at Buyer's expense. Time of delivery is an estimate only and is based upon the receipt of all information and necessary approvals. The shipping schedule shall not be construed to limit seller in making commitments for materials or in fabricating articles under this order in accordance with Seller's normal and reasonable production schedules.

Seller shall in no event be liable for delays caused by fires, acts of God, strikes, labor difficulties, acts of governmental or military authorities, delays in transportation or procuring materials, or causes of any kind beyond Seller's control. No provision for liquidated damages for any cause shall apply under this order. Buyer shall accept delivery within thirty (30) days after receipt of notification of readiness for shipment. Claims for shortages will be deemed to have been waived if not made in writing within ten (10) days after the receipt of the material in respect of which any such shortage is claimed. Seller is not responsible for loss or damage in transit after having received "In Good Order" receipt from the carrier. All claims for loss or damage in transit should be made to the carrier.

STANDARD TERMS AND CONDITIONS

QUINCY COMPRESSOR AND ORTMAN FLUID POWER DIVISIONS

TITLE & LIEN RIGHTS: The equipment shall remain personal property, regardless of how affixed to any realty or structure. Until the price (including any notes given therefore) of the equipment has been fully paid in cash, Seller shall, in the event of Buyer's default, have the right to repossess such equipment.

PATENT INFRINGEMENT: If properly notified and given an opportunity to do so with friendly assistance, Seller will defend Buyer and the ultimate user of the equipment from any actual or alleged infringement of any published United States patent by the equipment or any part thereof furnished pursuant hereto (other than parts of special design, construction, or manufacture specified by and originating with Buyer), and will pay all damages and costs awarded by competent court in any suit thus defended or of which it may have had notice and opportunity to defend as aforesaid.

STANDARD WARRANTY: Seller warrants that products of its own manufacture will be free from defects in workmanship and materials under normal use and service for the period specified in the product instruction manual. Warranty for service parts will be ninety (90) days from date of factory shipment. Electric Motors, gasoline and diesel engines, electrical apparatus and all other accessories, components and parts not manufactured by Seller are warranted only to the extent of the original manufacturer's warranty.

Notice of the alleged defect must be given to the Seller, in writing with all identifying details including serial number, type of equipment and date of purchase within thirty (30) days of the discovery of the same during the warranty period.

Seller's sole obligation on this warranty shall be, at its option, to repair or replace or refund the purchase price of any product or part thereof which proves to be defective. If requested by Seller, such product or part thereof must be promptly returned to seller, freight prepaid, for inspection.

Seller warrants repaired or replaced parts of its own manufacture against defects in materials and workmanship under normal use and service for ninety (90) days or for the remainder of the warranty on the product being repaired.

This warranty shall not apply and Seller shall not be responsible or liable for:

- (a) Consequential, collateral or special losses or damages;
- (b) Equipment conditions caused by fair wear and tear, abnormal conditions of use, accident, neglect or misuse of equipment, improper storage or damage resulting during shipping;
- (c) Deviation from operating instructions, specifications or other special terms of sale;
- (d) Labor charges, loss or damage resulting from improper operation, maintenance or repairs made by person(s) other than Seller or Seller's authorized service station.

In no event shall Seller be liable for any claims whether arising from breach of contract or warranty or claims of negligence or negligent manufacture in excess of the purchase price.

THIS WARRANTY IS THE SOLE WARRANTY OF SELLERS AND ANY OTHER WARRANTIES, WHETHER EXPRESS OR IMPLIED IN LAW OR IMPLIED IN FACT, INCLUDING ANY WARRANTIES OF MERCHANTABILITY AND FITNESS FOR PARTICULAR USE ARE HEREBY SPECIFICALLY EXCLUDED.

LIABILITY LIMITATIONS: Under no circumstances shall the Seller have any liability for liquidated damages or for collateral, consequential or special damages or for loss of profits, or for actual losses or for loss of production or progress of construction, whether resulting from delays in delivery or performance, breach of warranty, negligent manufacture or otherwise.

ENVIRONMENTAL AND OSHA REQUIREMENTS: At the time of shipment of the equipment from the factory, Quincy Compressor / Ortman Fluid Power will comply with the various Federal, State and local laws and regulations concerning occupational health and safety and pollution. However, in the installation and operation of the equipment and other matters over which the seller has no control, the Seller assumes no responsibility for compliance with those laws and regulations, whether by the way of indemnity, warranty or otherwise.



an EnPro Industries company

Quincy Compressor Products: 217.222.7700

E-mail: info@quincycompressor.com

Website: www.quincycompressor.com



© 2008 Quincy Compressor, an EnPro Industries company
All Rights Reserved. Litho in U.S.A.