

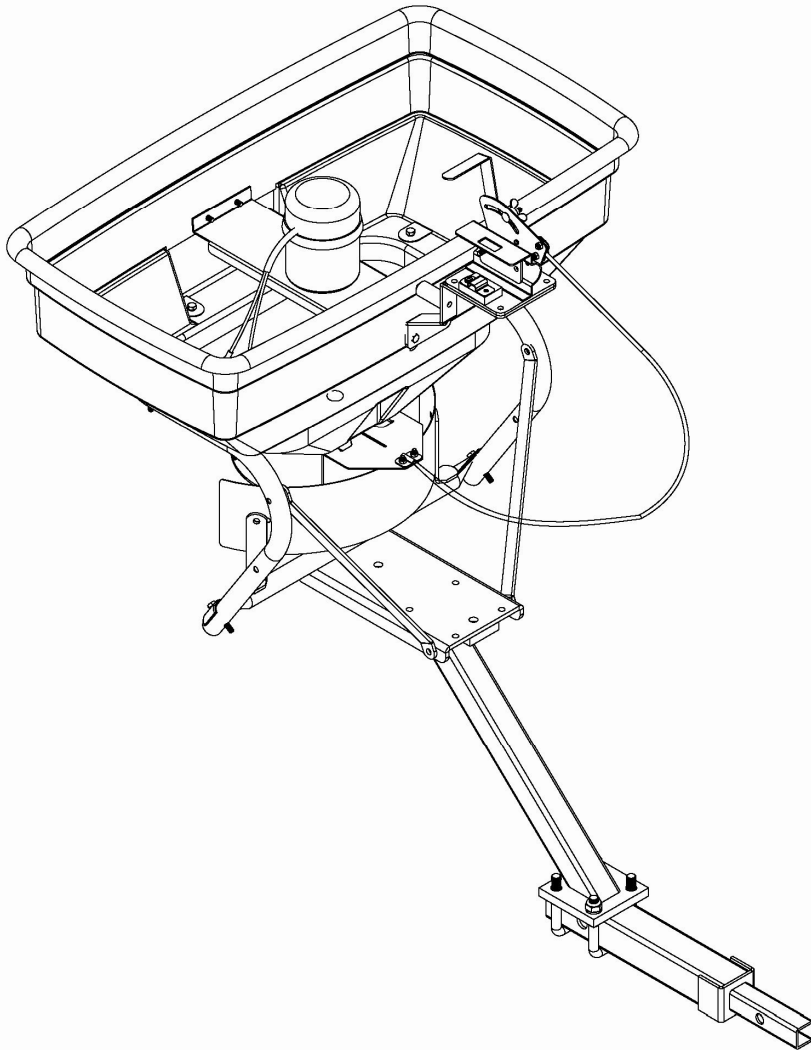

125LB ATV RECEIVER MOUNT SPREADER



12112012

Model AS-125ATV12

SAFETY PRECAUTIONS

1. Be sure to wear safety glasses, a dust mask, and proper clothing to prevent coming in contact with any chemicals or dangerous materials that are being applied by this spreader.
2. Make sure to remove any contents that are in the spreader's hopper before attaching, detaching, or lifting this unit.
3. Avoid attaching and detaching this unit alone. To avoid damage to this unit and injury always have someone help attach and detach due to shape and weight of this unit.
4. Always refer to the load rating for the vehicle which is located in the vehicle's owners manual. Make sure that the unit weight of 37lbs plus the weight of the contents in the hopper do not exceed that of the vehicle's recommended load rating.
5. To avoid damage to this unit and injury NEVER overload the hopper.
6. Stay clear of all moving and spinning parts or objects of this unit
7. Always follow directions on the package of whatever you are applying with this unit.

Operation Instructions

1. After assembly attach to front or rear receiver of vehicle.
2. Read and follow directions on the package of the material being spread by this unit.
3. Fill hopper with desired material to be spread by this unit not exceeding maximum load of 125lbs.
4. Adjust the handle on the gauge assembly so that it is at the desired setting. Then tighten the wing nut on the gauge assembly to set the desired opening. This allows the driver to set the opening to the same place every time while driving the vehicle. See page 3 for spread calculations.
5. Adjust handle on the gauge assembly until desired amount of spreading material is flowing out of the hopper onto the turning plate.
6. Flip rocker switch on cable assembly to on position and begin spreading.
7. Turn Rocker switch off when wanting to stop or pause spreading.
8. Empty and clean hopper when finished.

Note: Settings for this product need to be determined by user since factors such as coarseness and density of “material used” affect the spread rates. See page 3 “rate worksheet” to calculate approximate spread rates.

When Rate settings are not available, follow these guidelines to calculate spread rates:

On the bag of material to spread, you will find recommended spread rates, usually in terms to the effect of: so many pounds will cover so many sq. ft.

Read these steps, then refer to the guide (worksheet page 3)

- 1. Determine how much material to apply per 1,000 sq. ft.**
- 2. Measure off a distance of 50ft, preferably on a paved area (ie: parking lot)**
- 3. Weigh out enough material from bag to fill hopper ½ full (recommend at least ½ full hopper)
Record weight for later.**
- 4. Set the stop at position with opening of hopper at position you feel appropriate.**
- 5. Now with hopper ½ full, bring vehicle to desired speed before start line of your 50 ft test area.
When you arrive at start line, turn on spreader, then off at finish line**
- 6. Stop the vehicle and note the width of spread path from your test run.**
- 7. Repeat if necessary; Then empty remaining material from hopper back to your weighing device and record new weight.**
- 8. Be sure to record your results, see below guide on page 3.**

On the bag of material to spread, you will find recommended spread rates, usually in terms to the effect of: so many pounds will cover so many sq. ft.

Find your Desired Application (spread) Rate

Example: To find your desired rate, divide the area (sq. ft.) that bag of material covers by the weight of the bag of material itself. Then multiply by 1,000.

Example: 25lb bag / 2000 sq ft coverage = .0125
.0125 x 1,000 = 12.5 (12.5 is your desired lbs per 1,000 sq. feet)

Record Desired Rate = (lbs per 1,000 sq. ft.) _____

TEST RUN to DETERMINE SPREAD RATE:

- **Determine lbs (weight) of Material in Hopper for Test Area**
_____ **Weight of Material put into Hopper**
(Example: pour a 25lb bag into spreader)
(-) _____ Subtract Weight of Material in Hopper (After Test Area is spread)
(=) _____ Weight of Material Used (will be used below)
- **Test Area Measurements**
_____ **Length of Test Area (Recommend: 50 ft)**
(x) _____ Width of Spread Area
(=) _____ Total Spread Area
Determine Rate of Spread
Divide the Weight of Material Used in #2, by your Total Spread Area in #3.
Weight of Material Used/Total Spread Area = lbs per sq. ft.
Example: 2 lbs / 500 ft = .004
Multiply lbs per sq ft (x)1000 = _____ lbs per 1000 sq ft
Example: .004 x 1000 = 4
Compare these results to your desired application rate in #1.
Adjust the rate setting stop on the spreader accordingly and run test area again.
Example: Adjust 2 times more open to achieve double the rate of test.
Now you should approx. match your desired application in #1.
Repeat the process if necessary until you achieve your desired application rate.

Settings and guidelines furnished on this Rate Worksheet are intended as a guide only. Variations in materials applied, ground roughness, speed of operator, may affect rate. There is no warranty as to the rate of coverage derived from above guidelines.

Carton Contents

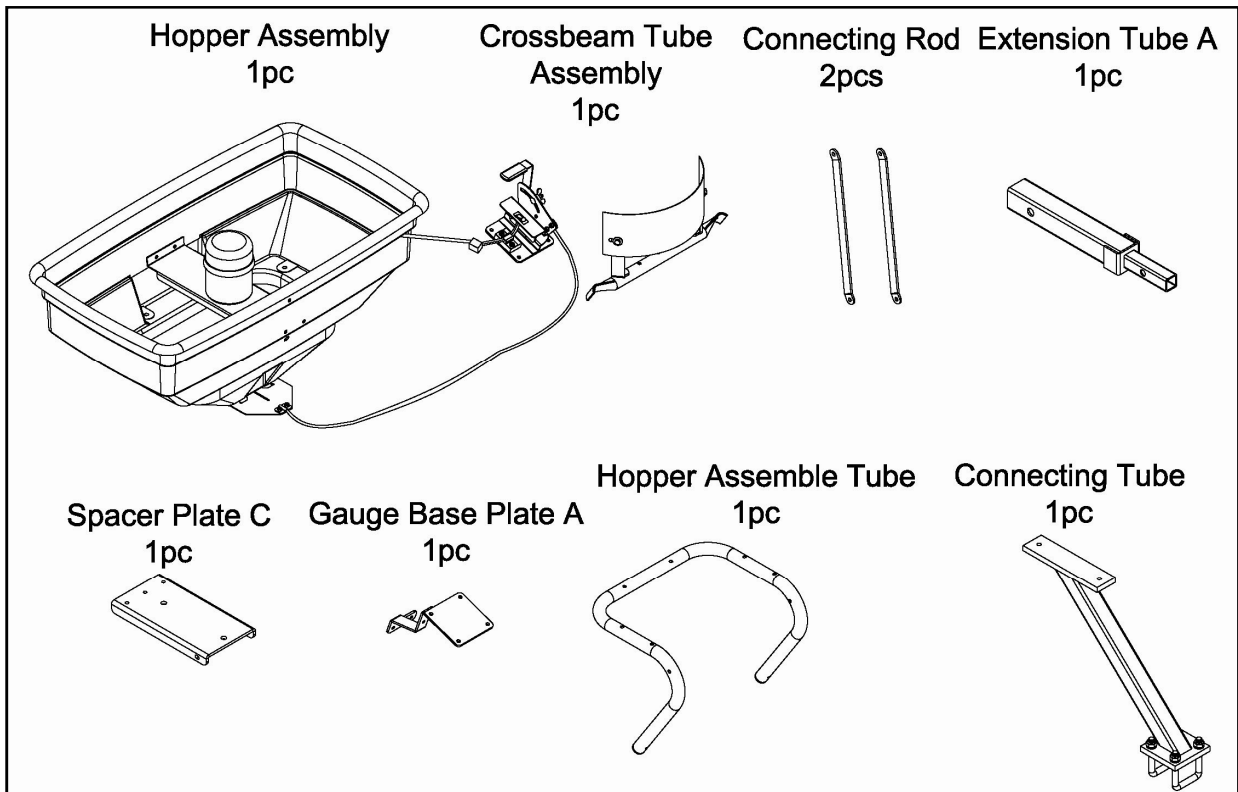
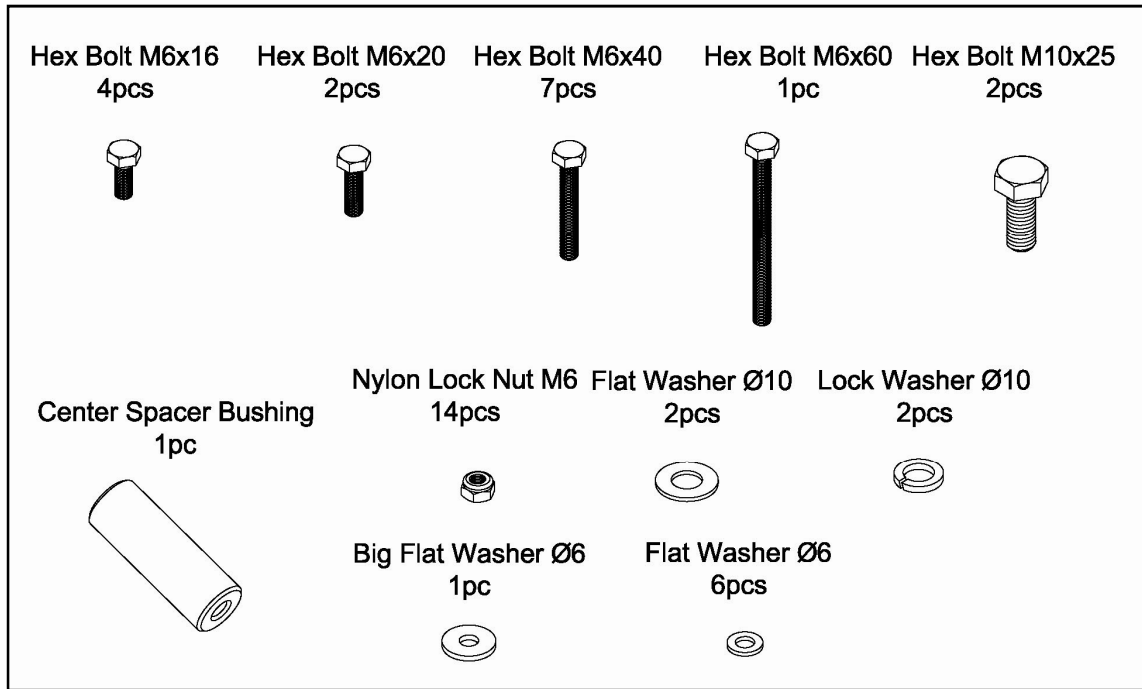

NOTE: If you have questions, problems, or missing parts please call our customer service before returning to your retailer. Contact us at 218-943-6296 ,8 a.m.-5 p.m., Monday-Friday CST.

Assembly Instructions

Step 1:

1. Connect the deflector plate (#16) to the crossbeam tube (#17) using hex bolt M6x16 (#5), hex lock nut M6 (#15) and big flat washer $\text{\O}6$ (#4). And then tighten them.
2. Connect the crossbeam tube (#17), connecting rod (#18) and hopper assemble tube (#14) using hex bolt M6x40 (#3), hex lock nut M6 (#15) and flat washer $\text{\O}6$ (#50). Don't tighten them.

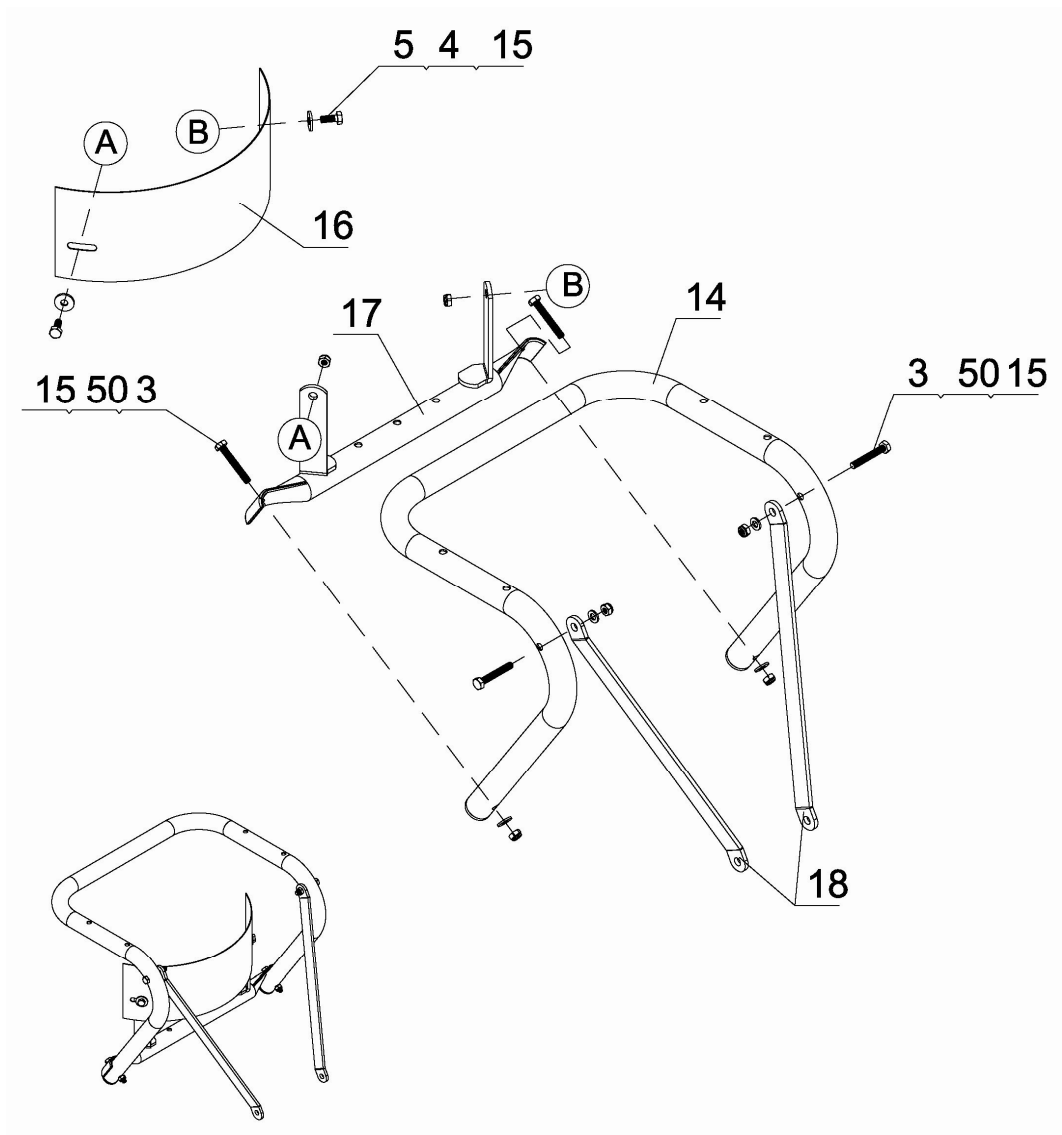

Step 2:

Assemble the connecting tube assembly (#25) and extension tube (#28) using “U” bolt (#29), lock washer Ø12 (#26) and hex lock nut M12 (#27), then tighten it. NOTE: extension tube (#28) can be reversed to fit 1.25” or 2” receiver (see step 7 for more detail.)

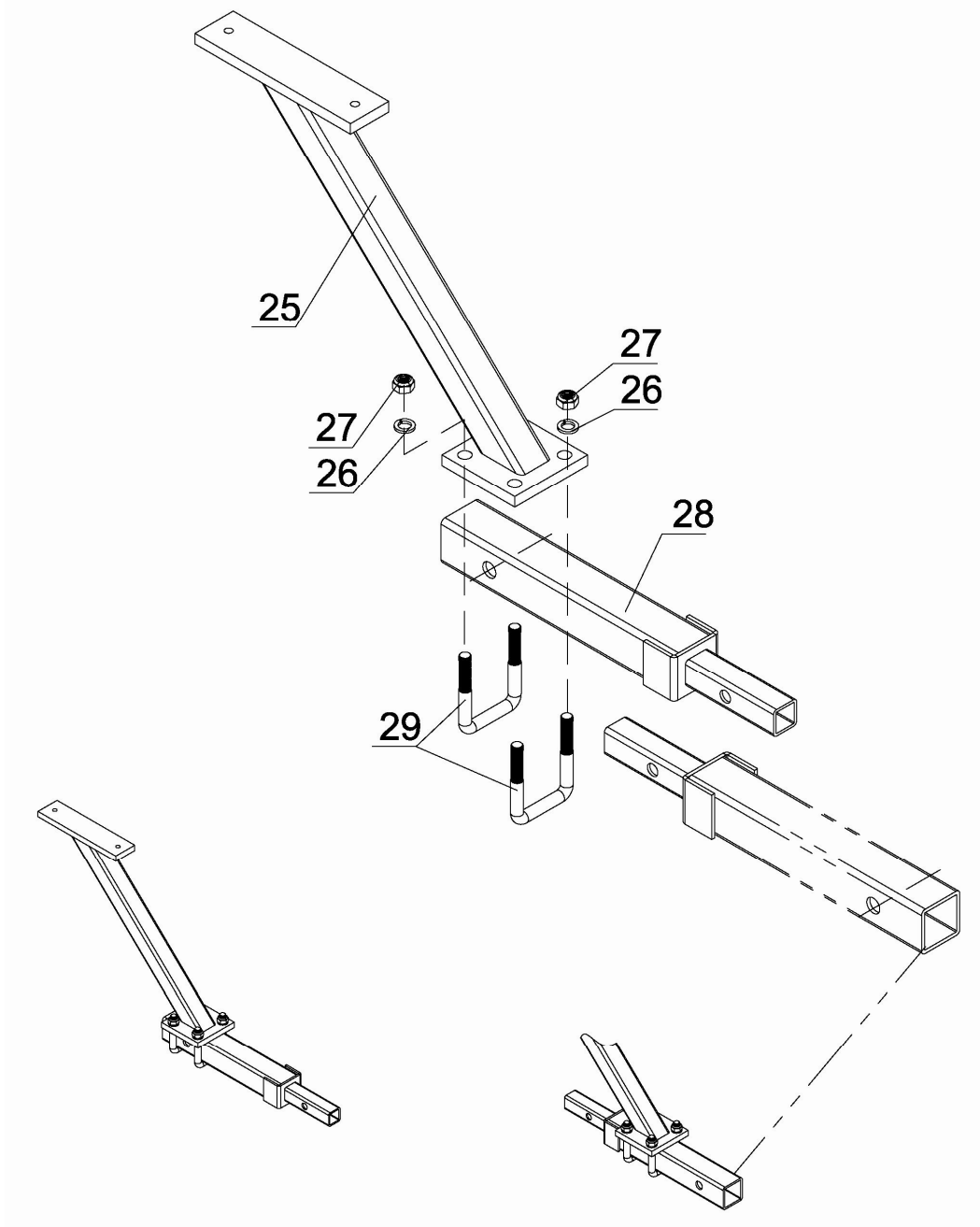

Step 3:

Connect the hopper assembly tube (#14) and spacer plate(#21) using hex bolt M6x40 (#3), hex bolt M6x20 (#20) ,hex lock nut M6 (#15) and flat washer Ø6 (#50). Fully tighten.

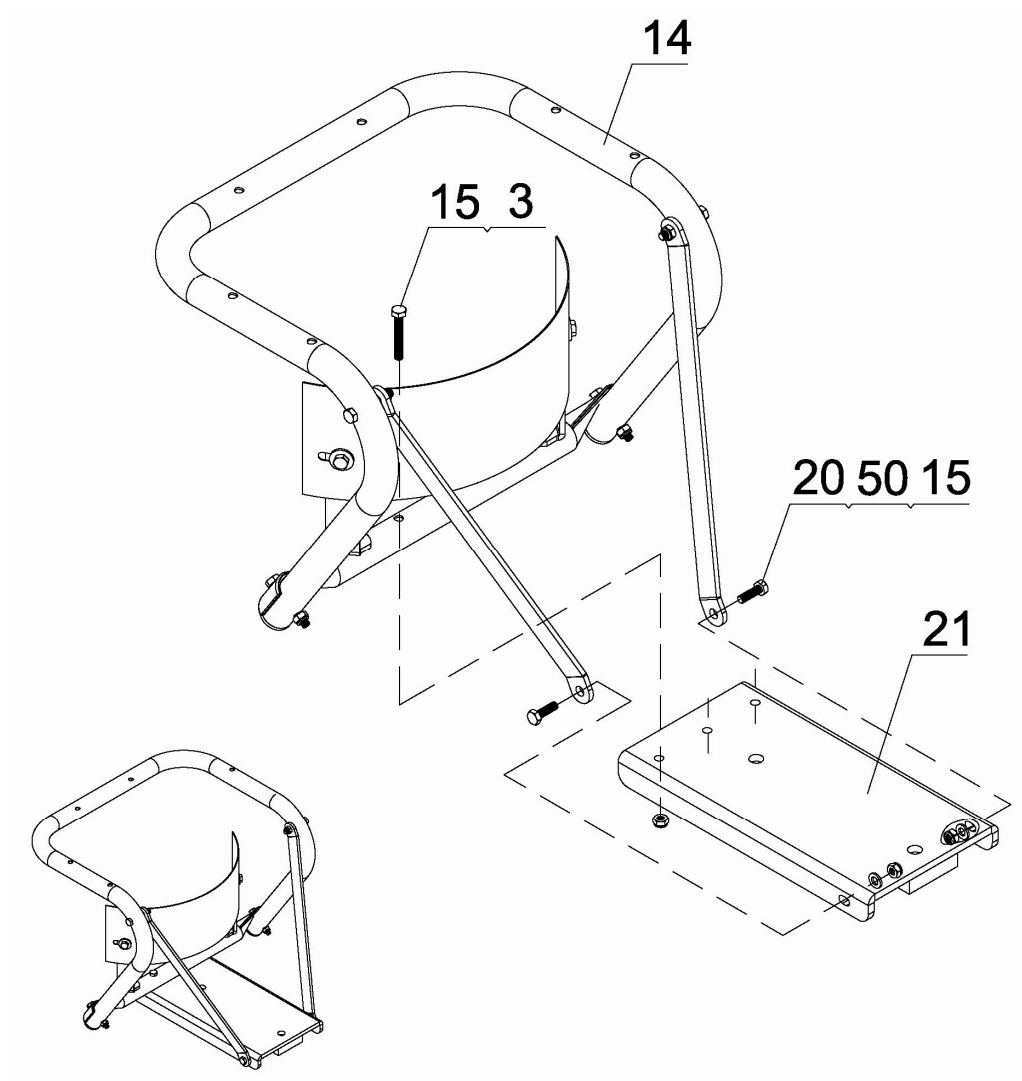

Step 4:

Assemble the connecting tube assembly (#25) and hopper tube assembly (#14) using hex bolt M10x25 (#22), lock washer Ø10 (#23) and flat washer Ø10 (#24). Fully tighten.

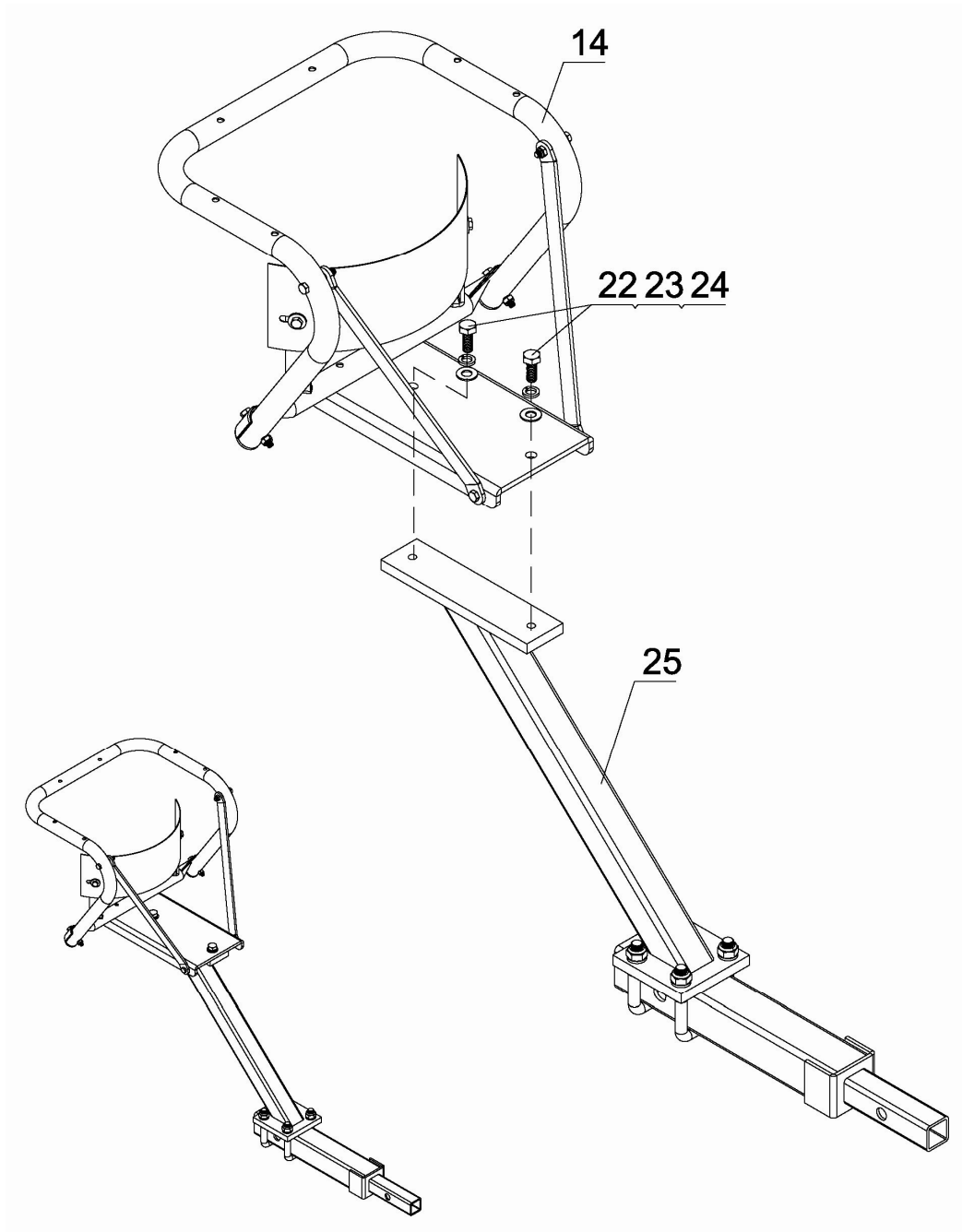

Step 5:

1. Pull out the switch box on the cable assembly , insert switch into the hole on the gauge base plate , then plug-in the cable, and connect the other end of the cable with the cable on the motor.
2. Secure the gauge base plate(#34) and cable assembly (#57) using screw M5x12 (#11), Spring washer Ø5 (#63) mounting the clamp press plate (#64).

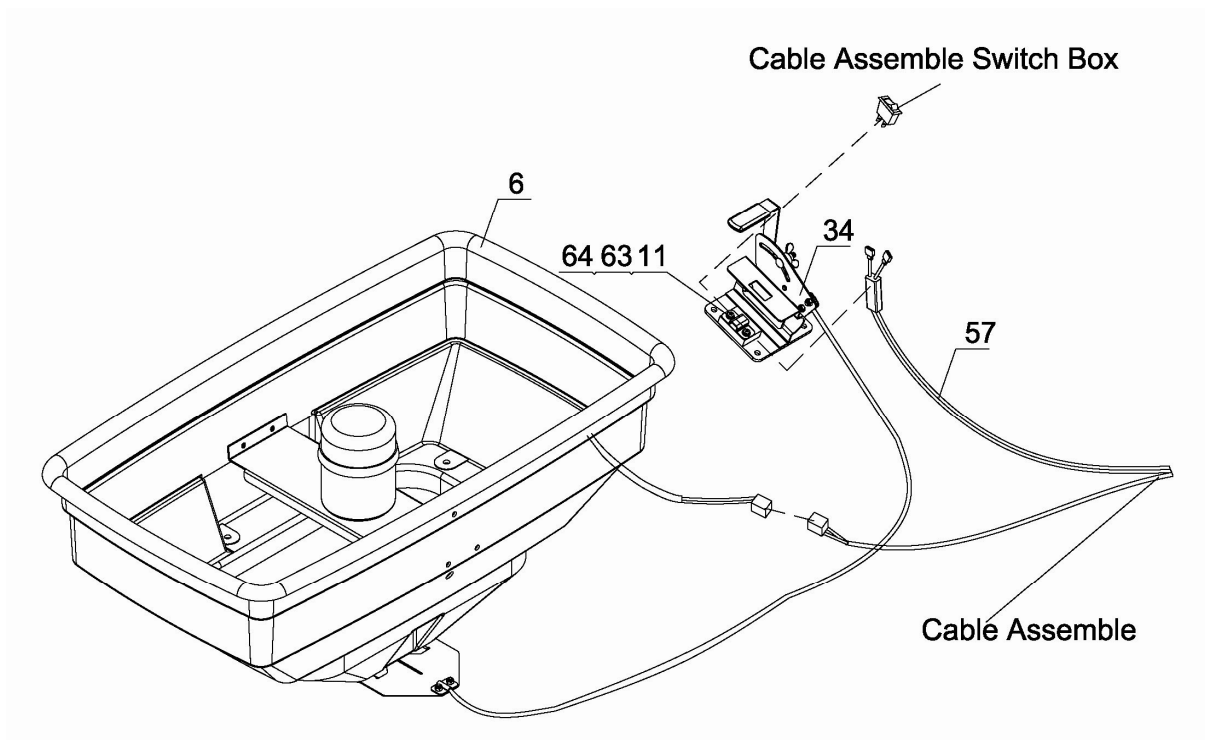

Step 6:

1. Connect the hopper assembly (#6) and hopper assemble tube (#14) using hex bolt M6x40 (#3), big flat washer $\varnothing 6$ (#4) and hex lock nut M6 (#15), then tighten.
2. Connect the gauge base plate (#31) center spacer busing(#30) and hopper assembly (#6) using hex bolt M6x60(#60), big flat washer $\varnothing 6$ (#4) and hex lock nut M6 (#15), then Connect the lower hole of gauge base plate (#31) and hopper assembly (#6) using hex bolt M6x16(#5) and hex lock nut M6 (#15). Then tighten all the bolts.
3. Attach the gauge base plate assembly (#34) onto gauge base plate (#31) using hex bolt M6x16(#5) and hex lock nut M6 (#15). Then tighten.

Please note: don't disassemble the bolts and nuts here firstly. Insert the bolts and nuts on the other side, then tighten here.

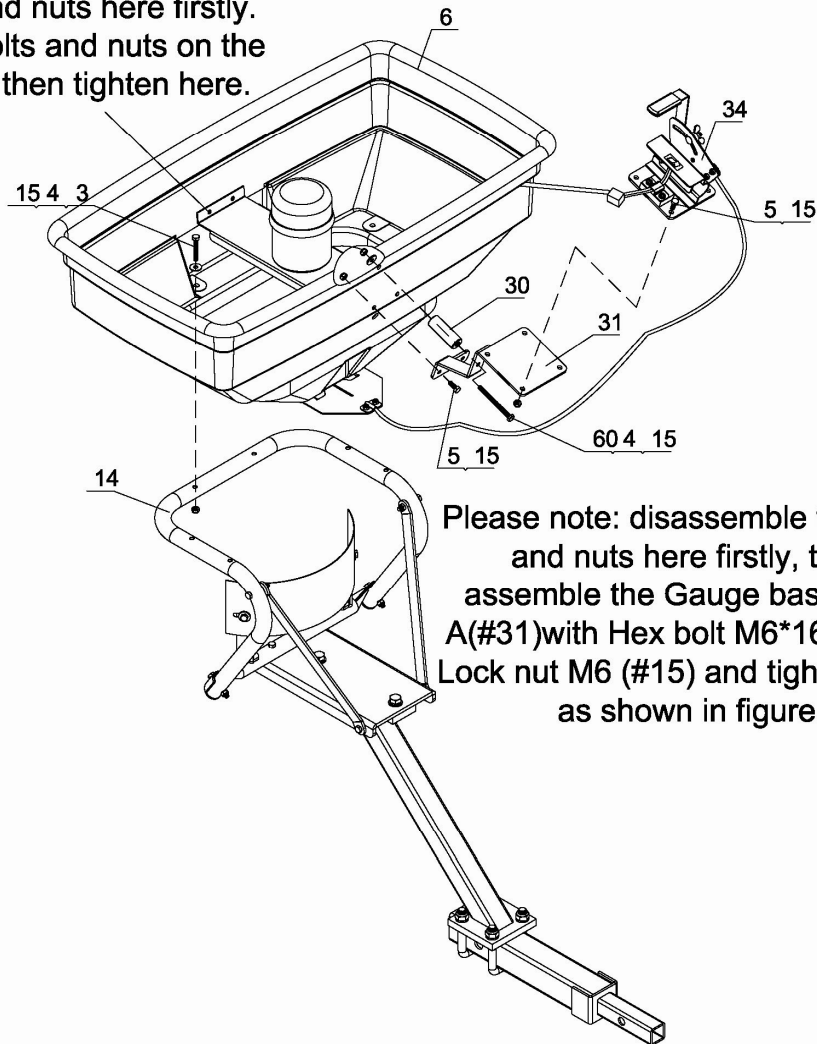

Step 7:
Tighten all the nuts and bolts.

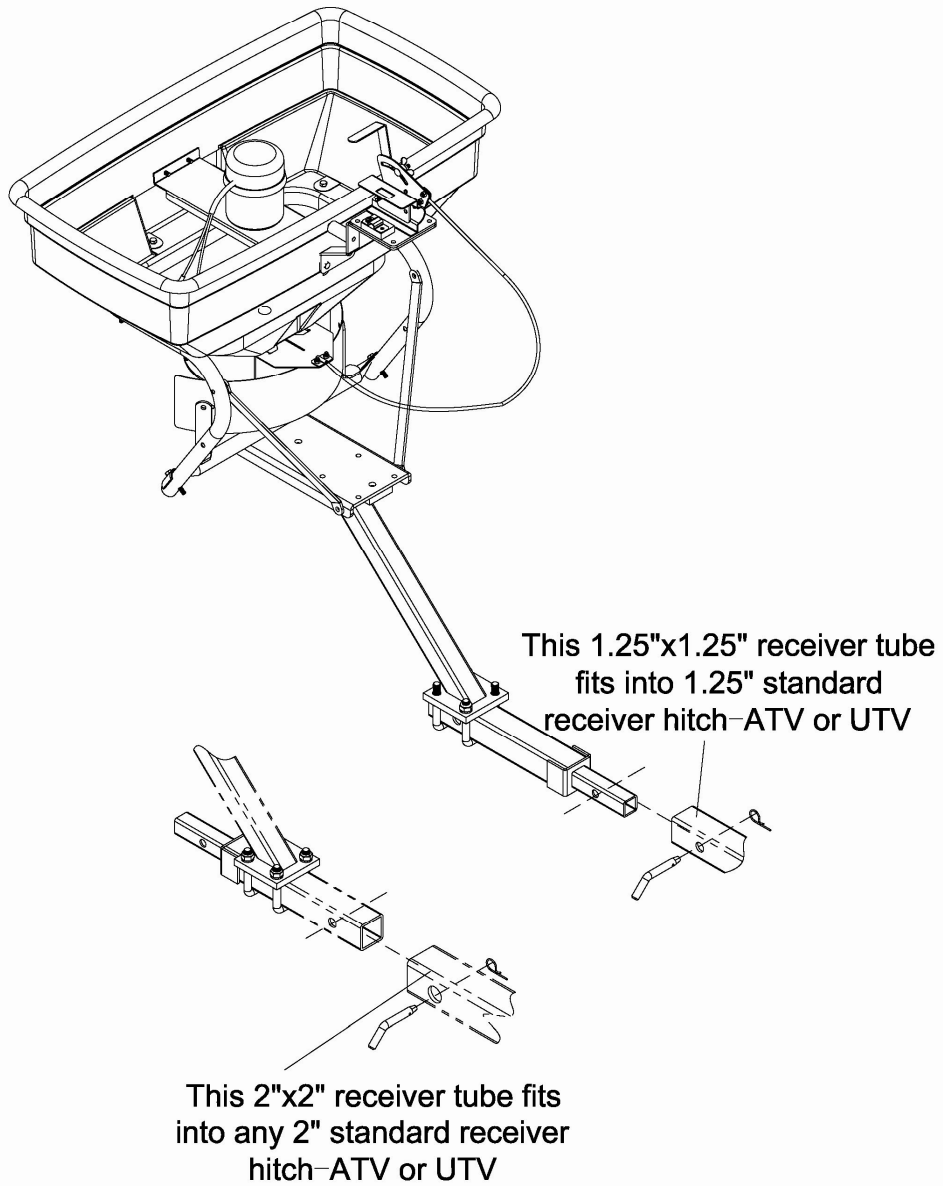

Exploded Diagram

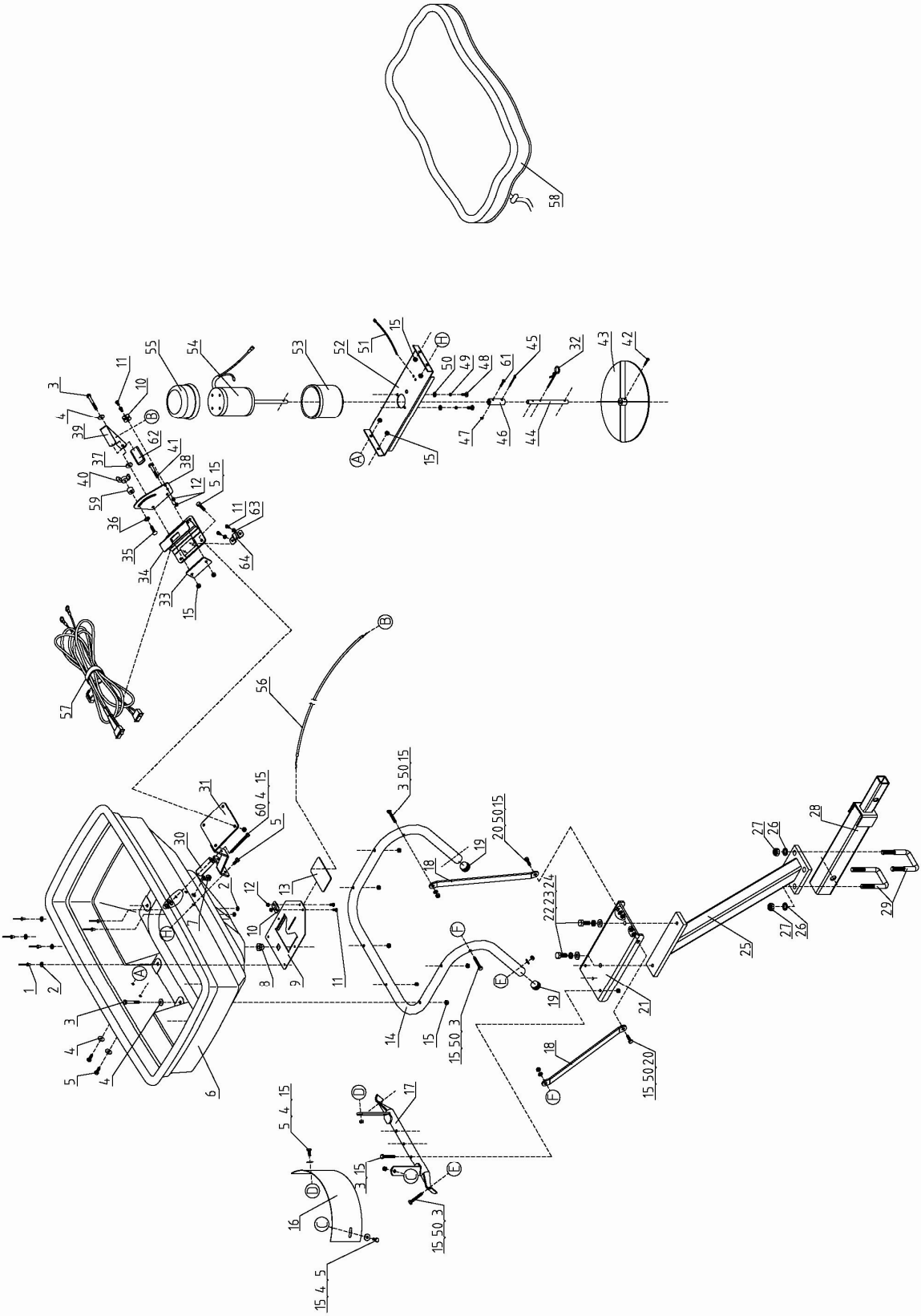

Part List

REF#	DESCRIPTION	QTY	REF#	DESCRIPTION	QTY
1	RivetΦ5x13	6	33	Fixed Plate	1
2	Big Flat WasherΦ5	6	34	Gauge Base Plate	1
3	Hex Bolt M6x40	14	35	Step Bolt M6X25	1
4	Big Flat WasherΦ6	12	36	External Teeth Lock Washer Φ8	1
5	Hex Bolt M6x16	10	37	Nylon Washer	1
6	Hopper Assembly	1	38	Gauge & Level Assembly	1
7	Wire Clamp	1	39	Adjustable Handle	1
8	Shaft Bushing	1	40	Wing Nut	1
9	Fixed Adjustable Plate	1	41	Hex Bolt M6x35	1
10	Link Clamp Press Plate	2	42	Screw M4X20	1
11	Screw M5x12	6	43	Impeller	1
12	Nylon Lock Nut M5	4	44	Shaft Φ10x135	1
13	Active Adjustable Plate	1	45	Cotter Pin Φ4x30	1
14	Hopper Assemble Tube	1	46	Shaft Connecting Tube	1
15	Nylon Lock Nut M6	28	47	Nylon Lock Nut M4	1
16	Deflector A	1	48	Screw M6x16	2
17	Crossbeam Tube Assembly	1	49	Lock Washer Φ6	2
18	Connecting Rod	2	50	Flat Washer Φ6	8
19	Tube End CapΦ25X13	2	51	Ribbon	1
20	Hex Bolt M6X20	2	52	Motor Assemble Plate	1
21	Spacer Plate C	1	53	Motor Cover	1
22	Hex Bolt M10x25	2	54	Motor	1
23	Lock Washer Φ10	2	55	Motor Cap	1
24	Flat Washer Φ10	2	56	Adjustable Rod Assembly	1
25	Connecting Tube Assembly	1	57	Cable Assembly	1
26	Lock Washer Φ12	4	58	Rain Cover	1
27	Hex Lock Nut M12	4	59	Spacer Bushing	1
28	Extension Tube A	1	60	Hex Bolt M6x60	1
29	"U"Bolt	2	61	Screw M4x25	1
30	Center Bushing	1	62	Handle Grip	1
31	Gauge Base Plate A	1	63	Spring Washer Φ5	2
32	R Pin	1	64	Link Clamp Press Plate A	1

For replacement parts and technical questions, please call 1-218-943-6296.

WARRANTY

One-year limited warranty



TG
PO Box 203
Miltona, MN 56354
Made in CHINA