

IF YOU ARE EXPERIENCING TROUBLE WITH THIS PRODUCT,
OR MISSING PARTS, PLEASE CALL 800-954-3310 FOR ASSISTANCE
DO NOT RETURN TO STORE

Max LINE

M7580 3/4" MASTER KIT 300 FT

INSTALLATION INSTRUCTIONS

PLANNING/LAYOUT

Before beginning the installation, create a plan as to the location of the air compressor and where you are going to mount the compressed air outlets. On the plan locate outlets, tees, and elbows if needed.

AIR COMPRESSOR

Use a flexible jumper hose from the air compressor to the filter regulator unit to reduce vibration to the Maxline tubing.

FILTER REGULATOR

Maxline tubing is resistant to most common petroleum based compressor oils. Some new synthetic oils will reduce the life of the tubing. A high quality filter regulator is recommended to catch oils entering the air system.

RATINGS

200 psi at 73°F • 160 psi at 140°F • ASTM F1282

BENDING THE TUBING

The Maxline tubing can be bent to hold any shape. Care should be taken not to kink the tubing, but rather bend the tubing in a sweeping radius around corners and obstacles. Elbow fittings are available for sharp corners.

ASSEMBLY OF THREADED COMPONENTS

Assemble all NPT threads with two wraps of teflon tape and then PIPE SEALANT which prevents thread galling.

TUBING INSTALLATION

Maxline tubing will expand and contract slightly with changes in temperature. Use supplied wall clips spaced every 5 ft.

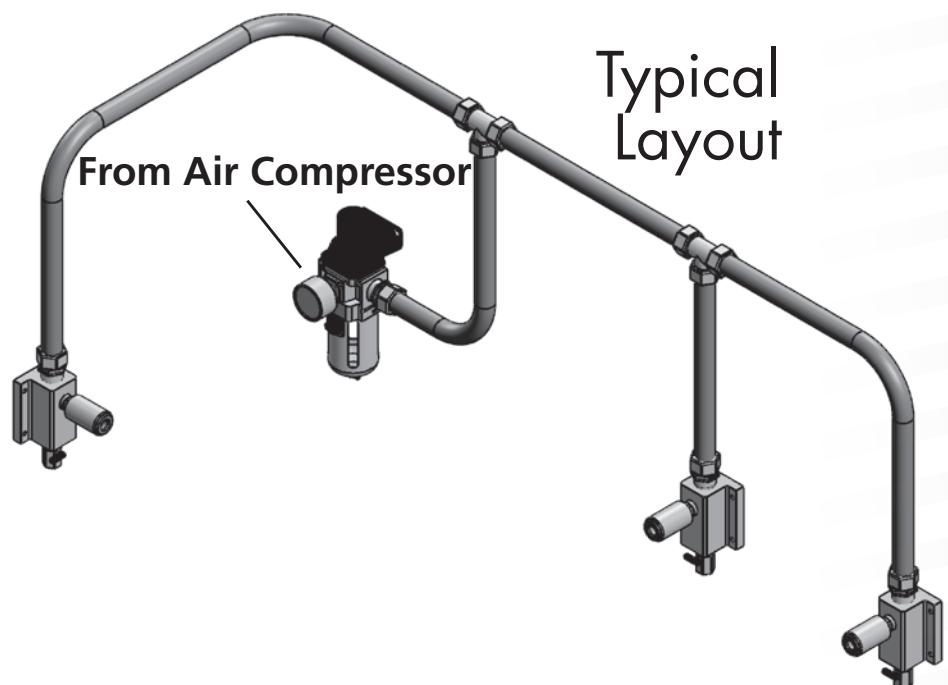

Tools and installation



1) CUT the tubing square with the cutter, ROTATING wrist while cutting



2) BEVEL the inside of the tubing by inserting the reaming tool and rotating it at least 3 full turns
- Use peg #25 for 3/4" tubing
Remove nut and split ring from fitting and place on tubing



3) PUSH the fitting onto the tubing and fully against the shoulder of the fitting (soapy water will help this process)



4) TURN the nut finger tight
Put a reference mark on the nut and fitting body

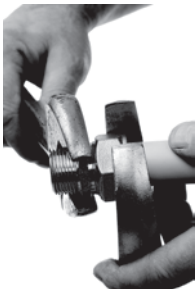

5) TIGHTEN nut with wrench a minimum 3/4 of a turn or until tight



M7580 MASTER KIT PARTS LIST

- 300ft 3/4" Maxline Tubing
- (3) M81010 Aluminum Blocks
- (3) M8005 3/4" Tubing x 1/2" NPT fittings
- (3) 50136 1/2" npt Plugs
- (3) 50120 3/8" npt Drain Valves
- (1) M8003 3/4" Tubing x 3/4" NPT Fitting
- (2) M8011 Tee Fittings
- (20) Tubing Clips
- Cutter and Bevel Tool



Front of block is ported
1/2" NPT Female
Coupler Not Included



no paste or teflon tape
required on fitting nuts

WARNINGS

- Regulate system pressure to a maximum of 200 psi.
 - Pressurize system slowly
 - Turn off air compressor when not in use
- Check local building codes before installation.
- Compressed air is dangerous if not used properly.
- Do not point compressed air source at any part of your body or at any person.
 - Always use eye protection when using compressed air.
- CA PROP 65: This product contains chemicals, including lead, known to the State of California to cause birth defects or other reproductive harm. **Wash hands after handling.**

CONTAINS LEAD: MAY BE HARMFUL IF EATEN OR CHEWED. MAY GENERATE DUST CONTAINING LEAD. KEEP OUT OF THE REACH OF CHILDREN.

Engineered Specialties, LLC • Auburndale, WI • 800-954-3310
For installation tips and warranty information, please visit www.RapidAirproducts.com