



READ  
CAREFULLY  
BEFORE USE

# Portable Winch Co.

**PORTABLE CAPSTAN GAS-POWERED PULLING WINCH™  
PCW3000**

## USER MANUAL

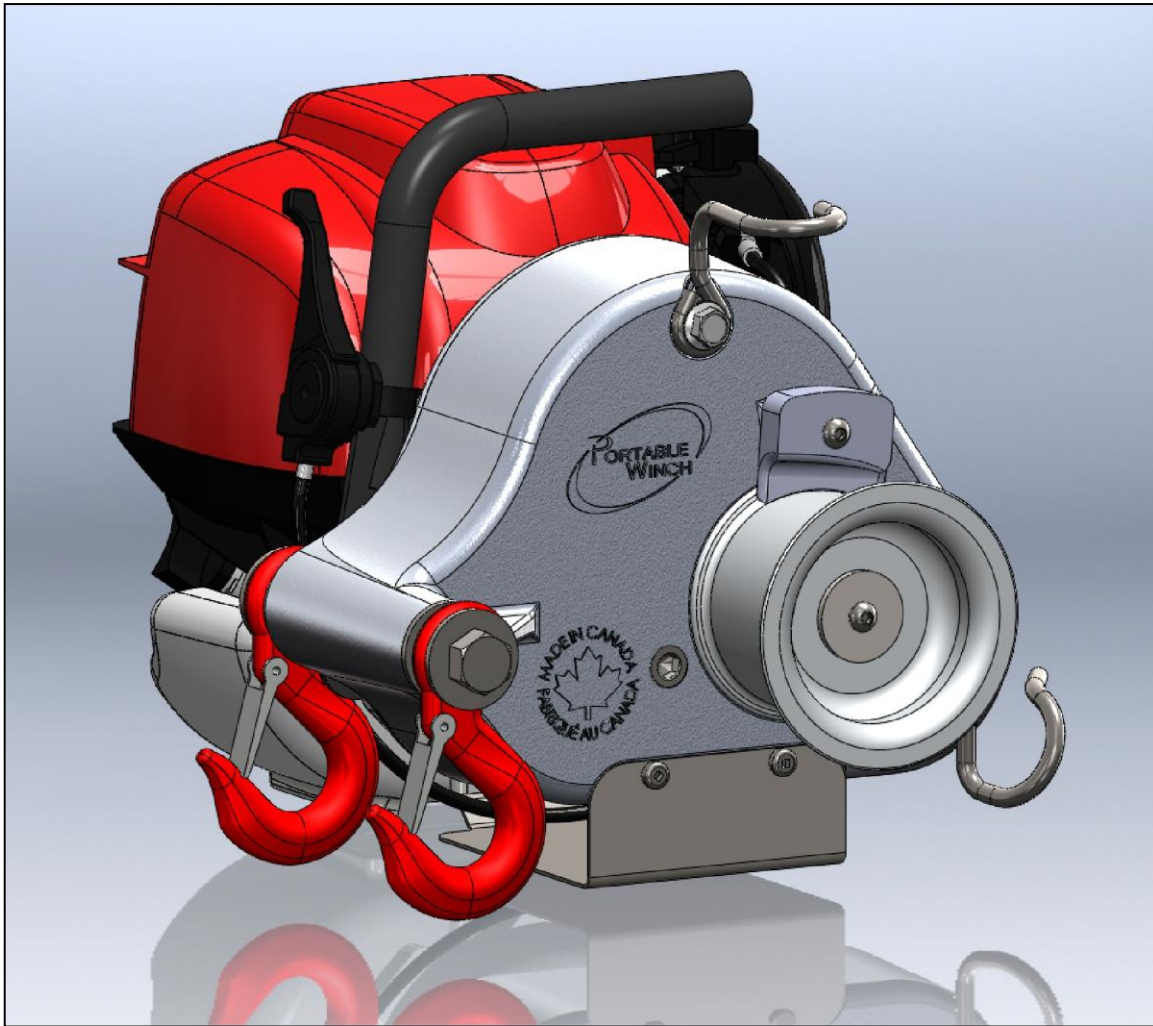

**Maximum pulling capacity (single line): 700 kg (1550 lb)**



facebook

[www.portablewinch.com](http://www.portablewinch.com)

© 2012 Portable Winch Co. - All Rights Reserved  
English version

## **Summary**

### **Introduction – p. 3**

#### **1.0 Safety guidelines – p. 3**

- 1.1 Safety messages – p. 3
- 1.2 Label – p. 3
  - 1.2.1 Serial number and warning label – p. 3
- 1.3 Safety information – p. 4

#### **2.0 Before first use – p. 5**

- 2.1 Upon receiving the winch – p. 5
- 2.2 Is the engine ready to work? – p. 5
  - 2.2.1 Engine oil – p. 5
  - 2.2.2 Gas (petrol) – p. 5
  - 2.2.3 Engine start-up – p. 5
  - 2.2.4 Capstan drum – p. 6
  - 2.2.5 Spark arrestor – p. 6

#### **3.0 Winch usage – p. 6**

- 3.1 Rope – p. 6
  - 3.1.1 Rope type – p. 6
  - 3.1.2 Rope maintenance – p. 7
- 3.2 At the end of the rope – p. 7
  - 3.2.1 Recommended knots – p. 7
  - 3.2.2 Recommended hooks – p. 7
- 3.3 Winch anchor – p. 8
  - 3.3.1 Using the polyester sling (included with the winch) – p. 8
  - 3.3.2 Using the hitch plate winch anchor for tow balls up to 50 mm (2") diameter – p. 9
  - 3.3.3 Using the winch support plate with square tubing 50 mm (2") – p. 9
  - 3.3.4 Using the winch support plate with Heck-Pack system for 50 mm European balls and winch support plate adaptor – p. 10
  - 3.3.5 Using the tree/pole mount with anchor strap – p. 11
    - 3.3.5.1 With the winch support plate – p. 12
    - 3.3.5.2 With the vertical pull winch support – p. 12
- 3.4 Rope installation – p. 13
  - 3.4.1 Rope – p. 13
  - 3.4.2 Pulley – p. 13
  - 3.4.3 Direction – p. 14
  - 3.4.4 On a hill – p. 14
- 3.5 Pulling a load – p. 14
  - 3.5.1 Wrapping the rope on the capstan drum – p. 14
  - 3.5.2 Winching – p. 15
    - 3.5.2.1 If the rope slips – p. 15
    - 3.5.2.2 To "rock" the load – p. 15
    - 3.5.2.3 How to pause while winching – p. 15
    - 3.5.2.4 If your rope is too short – p. 16
  - 3.5.3 Stopping the winch – p. 16

#### **4.0 Maintenance – p. 16**

- 4.1 Cleaning – p. 16
- 4.2 Lubrication – p. 17
- 4.3 Honda engine – p. 17
- 4.4 Storage – p. 17
- 4.5 Spark arrestor – p. 17

#### **5.0 Complementary information – p. 17**

- 5.1 Accessories – p. 17
- 5.2 Warranty – p. 18
- 5.3 Serial number localization – p. 18
- 5.4 CE Declaration of conformity – p. 19
- 5.5 Exploded view and parts list – p. 20
- 5.6 Technical data – p. 22
- 5.7 Manufacturer – p. 22

## Introduction

Portable Winch Co. wishes to thank you for purchasing a *Portable Capstan Winch™*. This manual was written to help you make the best use of your new winch and to use it in the most secure way. **READ IT CAREFULLY BEFORE USING THE WINCH.** For any problems or questions please refer to an authorized Portable Winch Co. dealer or contact us directly.

## 1.0 Safety guidelines

This *Portable Capstan Winche™* is designed to pull **non-rolling objects**, usually at a plus or minus 45 degree angle from the horizontal. The use of a pulling device implies serious risks of injuries, property damage or even death. **Do not underestimate its potential danger.**

### 1.1 Safety messages

Your safety and the safety of others are very important. You will find important safety messages in this manual. **Read them carefully.**

These security messages are warning you of potential injuries to either you or others. Every safety message is preceded by a warning symbol and one of the following terms: DANGER, WARNING or CAUTION.

**These indicator words mean:**

**DANGER** You WILL be MORTALLY or SEVERELY INJURED if you do not follow these instructions.

**WARNING** You COULD be MORTALLY or SEVERELY INJURED if you do not follow these instructions.

**CAUTION** You COULD be INJURED if you do not follow these instructions.

### 1.2 Label

#### 1.2.1 Serial number and warning label

The *serial number and warning label* is positioned on the right side of the winch housing. See the meaning of all four icons in the figure 1.

1. Read this instruction manual and Honda engine user's manual prior to using the winch.
2. Only use low-stretch rope. Minimum diameter: 10 mm (3/8"). Maximum diameter: 16 mm (5/8").
3. Never place your hands near the drum while the engine is running.
4. Never use the winch for lifting people.

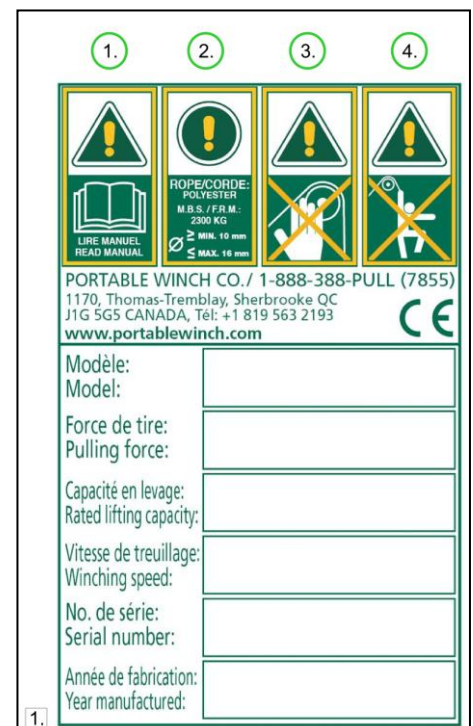

### 1.3 Safety information

**⚠ WARNING** DO NOT LET CHILDREN USE THE *PORTABLE CAPSTAN WINCH™*. KEEP CHILDREN AND ANIMALS AWAY FROM THE WORK AREA.

**⚠ WARNING** NEVER LET SOMEONE WITHOUT TRAINING USE THE *PORTABLE CAPSTAN WINCH™*. MAKE SURE THE USER KNOWS ABOUT THE SAFETY AND USAGE PROCEDURES AND HAS READ THIS MANUAL AND THE HONDA ENGINE USER MANUAL.

**⚠ WARNING** INFORM ALL USERS OF THE SAFETY GUIDELINES AND USAGE PROCEDURES.

**⚠ WARNING** FAMILIARIZE YOURSELF WITH THE PRODUCT AND THE SAFETY GUIDELINES BEFORE WORKING WITH THE *PORTABLE CAPSTAN WINCH™*.

**⚠ WARNING** MAKE SURE THAT YOUR CLOTHES ARE NOT GOING TO GET CAUGHT INTO THE *PORTABLE CAPSTAN WINCH™* MOBILE PARTS.

**⚠ DANGER** THE EXHAUST GAS CONTAINS TOXIC CARBON MONOXIDE. NEVER RUN THE ENGINE IN A CLOSED AREA WITHOUT PROPER VENTILATION.

**⚠ CAUTION** REPLACE ANY SAFETY LABELS THAT ARE DAMAGED, ILLEGIBLE OR MISSING.

**⚠ WARNING** NEVER PUT YOUR HANDS ON THE CAPSTAN DRUM OR NEAR THE ROPE GUIDE ROPE ENTRY HOOK WHEN THE ENGINE IS RUNNING.

**⚠ WARNING** ALWAYS KEEP BYSTANDERS OUTSIDE THE WORKING AREA.

**⚠ DANGER** NEVER PULL ROLLING OBJECTS THAT MIGHT ROLL OUT OF YOUR CONTROL.

**⚠ WARNING** THE *PORTABLE CAPSTAN WINCH™* IS NOT INTENDED FOR LIFTING PURPOSES.

**⚠ WARNING** NEVER USE THE *PORTABLE CAPSTAN WINCH™* TO LIFT PEOPLE.

**⚠ CAUTION** ALWAYS WEAR GLOVES.

**⚠ CAUTION** WE RECOMMEND WEARING HEARING PROTECTION.

**⚠ CAUTION** DO NOT TOUCH THE CAPSTAN DRUM IMMEDIATELY AFTER OPERATION AS IT WILL GET HOT AND BURN BARE SKIN.

## **2.0 Before first use**

### **2.1 Upon receiving the winch**

Inspect the box to detect any apparent damage. If there is damage or missing parts, inform the carrier immediately.

### **2.2 Is the engine ready to work?**

#### **2.2.1 Engine oil**

Fill the Honda engine with 10 centiliters of SAE 10W-30 API SJ oil. For special usage or conditions such as extreme weather, refer to the Honda engine user manual. Check the oil level on a horizontal surface. The oil level should be up to the edge of the opening.

#### **2.2.2 Gas (petrol)**

Fill the gas (petrol) tank with **UNLEADED PETROL**. Do not use oil/gas (petrol) mixture; your *Portable Capstan Winch™* is equipped with a 4-stroke engine. Refer to the Honda engine user manual.

#### **2.2.3 Engine start-up**

Refer to the Honda engine user manual for start-up instructions.

**FIRST USE: LET THE ENGINE RUN FIVE (5) MINUTES AT IDLE BEFORE FIRST PULL.**

The engine on/off switch is located on the winch engine, to the left of the gas (petrol) tank (figure 1).



Make sure to pull on the recoil starter in the axis of the rope outlet (figure 1 below). If you pull diagonally (figure 2 below) the friction of the rope on the plastic cover might damage the rope and/or the cover.

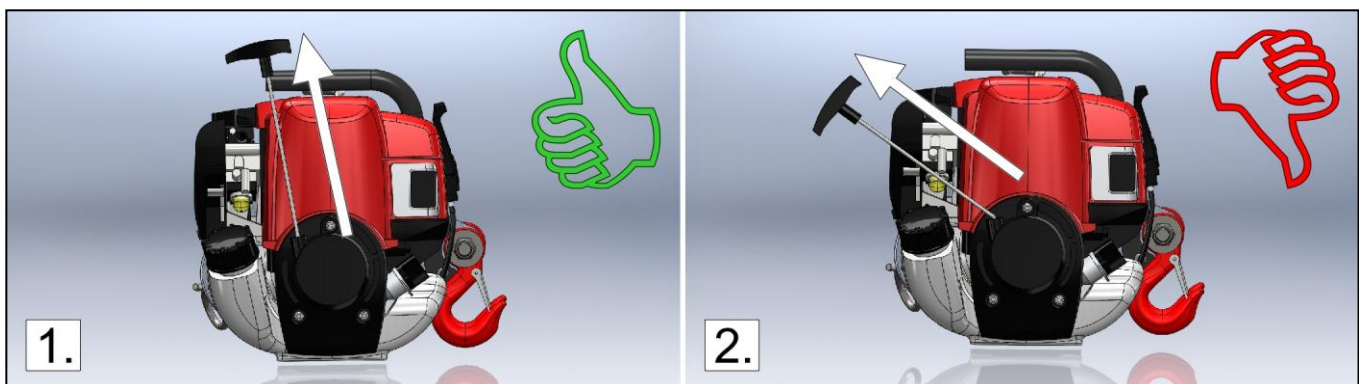

### 2.2.4 Capstan drum

Your *Portable Capstan Winch™* is equipped with a 76 mm (3") capstan drum. Only one (1) size drum fits this winch.

### 2.2.5 Spark arrestor

In certain areas, it is forbidden to use a gas (petrol) engine without a spark arrestor. Your *Portable Capstan Winch™* is equipped with an internal spark arrestor. Therefore, there is no need to worry about local regulation.

## 3.0 Winch usage

**⚠ WARNING** MOST WINCHING SITUATIONS PRESENT **POTENTIAL DANGERS!**

### 3.1 Rope

**⚠ WARNING** STAY OUT OF THE WINCH LINE'S PATH.

#### 3.1.1 Rope type

Use only **low stretch** rope. We recommend using double-braided polyester rope with a minimum diameter of 10 mm (3/8"). Maximum rope diameter is 12-13 mm (1/2"). Please contact us for other rope types suitability.

**⚠ WARNING** DO NOT USE 3-STRAND POLYPROPYLENE YELLOW ROPE!

- ⚠ Polypropylene and polyethylene ropes are dangerous for winching because of their great elasticity and low melt point.
- ⚠ Make sure the rope is not damaged and that it offers an adequate resistance to pull the load.

**⚠ WARNING** STRETCH EQUALS DANGER!

- ⚠ A stretched rope can recoil and cause serious burns as the rope leaves your hand.
- ⚠ All ropes stretch: a longer one more than a shorter one. The more you pull, the more it stretches.
- ⚠ A stretched rope can also move the load in an unpredictable or dangerous way.
- ⚠ A stretched rope can recoil and bring your hand towards the winch causing severe injuries. **NEVER WRAP THE ROPE AROUND YOUR HAND.**

**⚠ CAUTION** ALWAYS WEAR **GLOVES.**

### 3.1.2 Rope maintenance

**⚠ CAUTION** VISUALLY INSPECT YOUR ROPE **BEFORE EACH USAGE**. IF IT SHOWS ANY SIGN OF DETERIORATION (CUT STRANDS, EXCESSIVE ABRASION) REPLACE IT.

**⚠ CAUTION** IF YOUR ROPE IS DIRTY, WASH IT. DIRTY ROPES DETERIORATE FASTER AND CAUSE PREMATURE WEAR ON PARTS WHICH ARE IN CONTACT WITH THE ROPE.

### 3.2 At the end of the rope

#### 3.2.1 Recommended knots

You have to attach the load to the end of the rope. Even if a simple knot can do the job, we recommend the installation of a hook with the bowline knot (figure 1 on the right) because it can be easily undone if you need to change the hook. Moreover, it retains about 70% of the rope's capacity while most knots will reduce it by more than 50%.

Even better, the double bowline knot (figure 2) will keep about 75% of your rope's capacity.

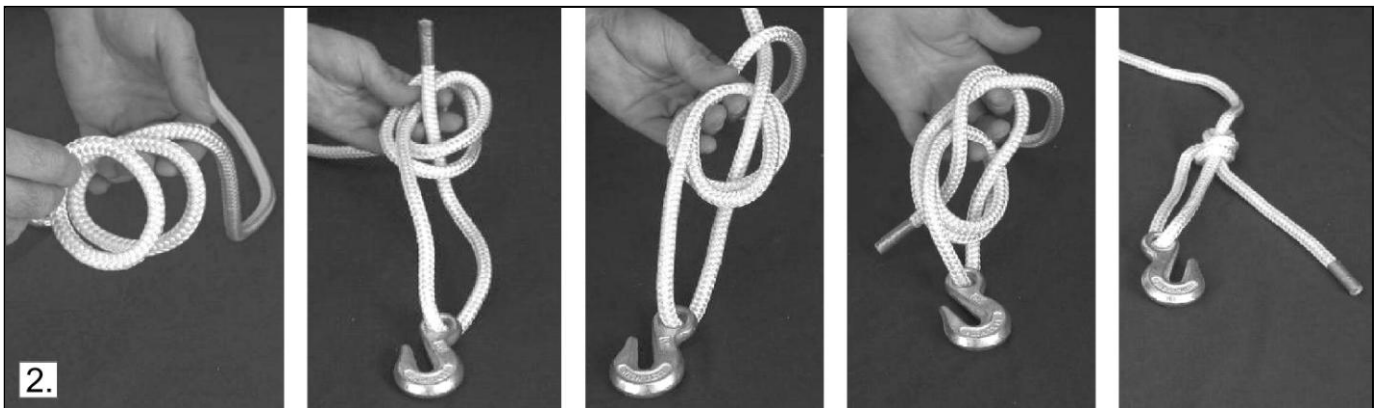
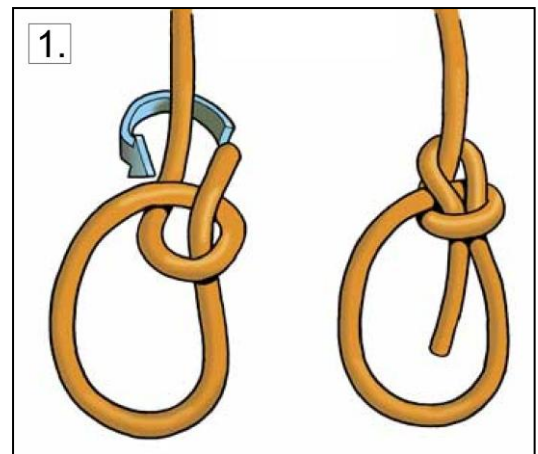

#### 3.2.2 Recommended hooks

If you usually pull with a choker chain, use a grab hook (figure 1) or grab hook with latch (figure 2). If you usually pull a sling or a ring, use a safety hook with latch (figure 3) or shackle (figure 4).



### 3.3 Winch anchor

**OPTION 1:** In most cases, the winch is anchored to a fixed point using the included polyester sling or with optional anchoring devices and the rope end is tied to the object you want to move. The load is moving towards the winch when you pull the rope.

**OPTION 2:** Alternately, the winch can be anchored to the load that needs to be moved and the rope end is tied to a fixed point. The winch and the load are therefore pulled toward the fixed point where the rope end is tied. This method is useful when you need to guide the load while you operate the winch.

#### 3.3.1 Using the polyester sling (included with the winch)

Go around the anchor point with the sling. Insert each end of the sling in one of the safety hooks located on the winch (figure 1 below).

Position the winch in line with the load. When the winch is under tension, it will try to align itself with the load. The friction of the sling against the anchor point could prevent correct alignment. If that is the case, release the tension on the rope and position the sling on the anchor point so that the tension is equally distributed on both winch anchor hooks.

**⚠ CAUTION** **DON'T DO THIS!** WHEN YOU ANCHOR THE WINCH, MAKE SURE THAT YOU **DO NOT** DO A COMPLETE WRAP AROUND THE ANCHOR POINT (FIGURE 2 BELOW). THIS SET-UP WILL PREVENT PROPER ALIGNMENT OF THE WINCH WITH THE LOAD AND WILL PUT UNEVEN TENSION ON THE WINCH ANCHOR HOOKS.

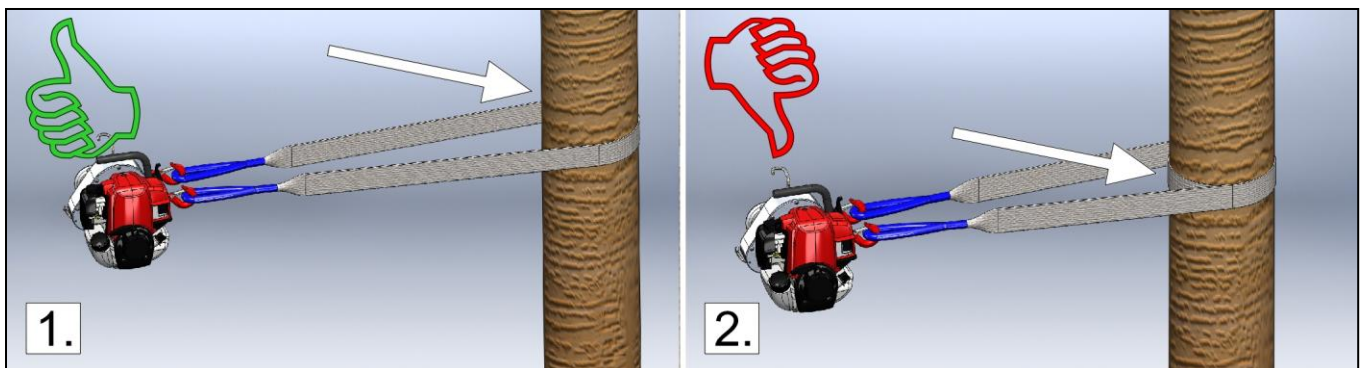

**⚠ CAUTION** AVOID INSTALLING THE SLING ON SHARP EDGES THAT MIGHT DAMAGE IT. WHETHER YOU ARE USING A POST, A TREE OR A STUMP, ALWAYS INSTALL THE SLING NEAR THE ANCHOR'S BASE.

**⚠ CAUTION** USING A STUMP AS AN ANCHOR POINT MEANS PAYING SPECIAL ATTENTION IN ORDER TO PREVENT THE SLING FROM SLIPPING OVER IT.

**⚠ WARNING** MAKE SURE THE ANCHOR POINT IS STRONG ENOUGH TO RESIST THE PULL WITHOUT BREAKING OR BEING DAMAGED.

### 3.3.2 Using the hitch plate winch anchor (PCA-1261) for tow balls up to 50 mm (2") diameter

- 1) Figure 1: Push the safety hooks in the rectangular openings of the hitch plate. The rubber plate must be under the winch;
- 2) Figure 2: Start the winch engine;
- 3) Figure 3: Slide the plate on the ball hitch and pull the winch forward;
- 4) Figure 4: Wrap the rope around the drum and start winching. The winch will align itself automatically with the load.

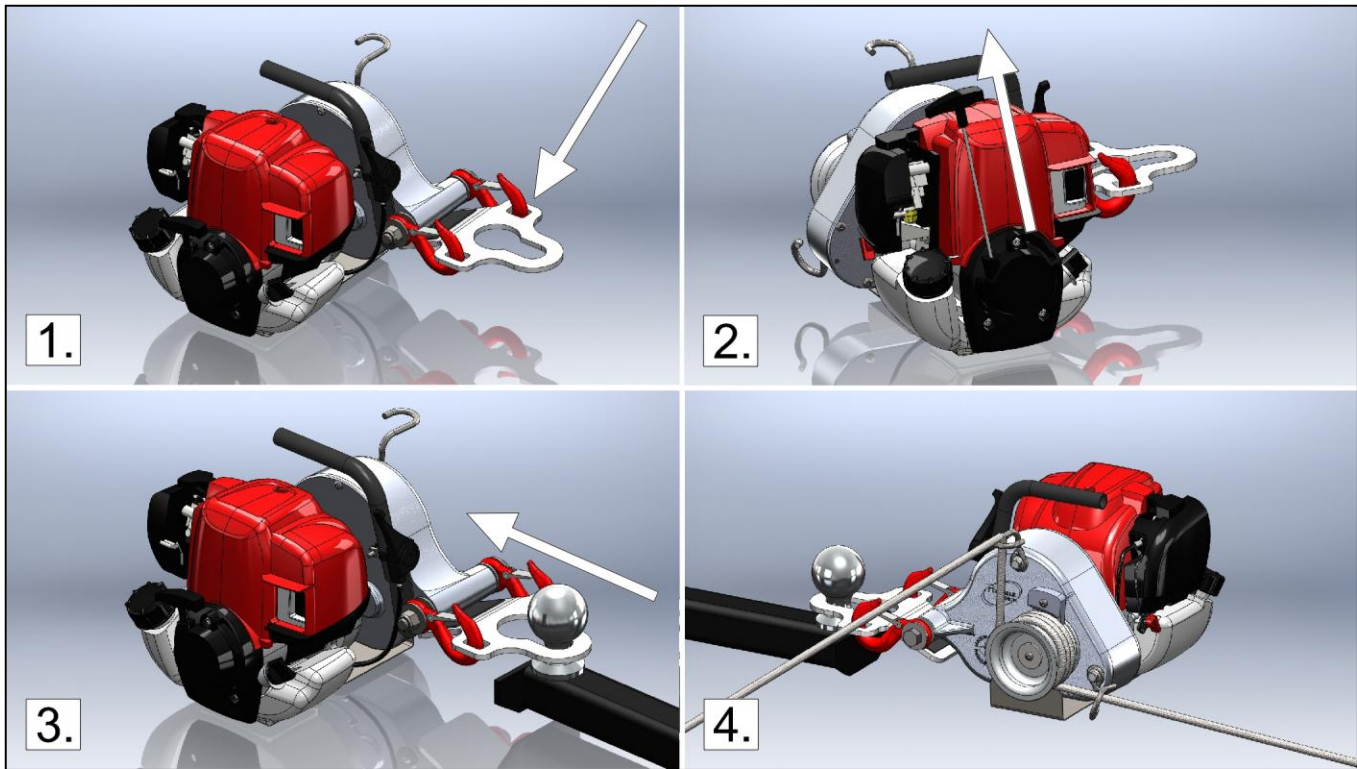

**⚠ CAUTION** USE THE HITCH PLATE ONLY WITH CATEGORY II BALL HITCH (1500 KG (3300 LB)) OR HIGHER. MAKE SURE THE ANCHORING VEHICLE'S HAND BRAKE IS ON AND WORKING PROPERLY. POSITION BLOCKS BEHIND THE WHEELS TO PREVENT ROLL BACK.

### 3.3.3 Using the winch support plate (PCA-1268) with square tubing 50 mm (2") (PCA-1267)

- 1) Figure 1, no. 1: Slide the square tubing (PCA-1267) into the vehicle's receiver and secure it with both the hitch pin and the "R" pin;
- 2) Figure 1, no. 2: Slide the winch support plate (PCA-1268) onto the square tubing and secure it with both the hitch pin and the "R" pin;  
**Note:** Its lateral movement can be adjusted by positioning the bolts into the square holes;
- 3) Figure 2: Attach the winch anchor hooks to the eye bolts;
- 4) Figure 2: Wrap the rope around the drum and start winching. The winch will align itself automatically with the load.

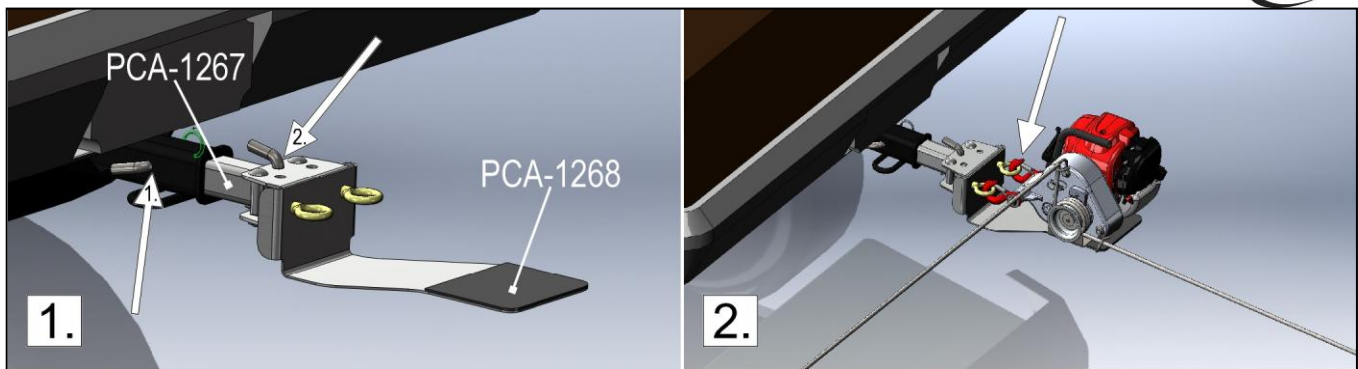

**⚠ CAUTION** IF YOU NEED TO PULL DOWNWARD, YOU WILL NEED TO INSTALL EITHER A PULLEY OR A ROLLER TO PREVENT DAMAGE TO THE WINCH SUPPORT PLATE.

**⚠ CAUTION** MAKE SURE THE ANCHORING VEHICLE'S HAND BRAKE IS ON AND WORKING PROPERLY. POSITION BLOCKS BEHIND THE WHEELS TO PREVENT ROLL BACK.

**3.3.4 Using the winch support plate (PCA-1268) with Heck-Pack system for 50 mm European balls (PCA-1266) and winch support plate adaptor (PCA-1265)**

- 1) Figure 1: Bolt the winch support plate adaptor (PCA-1265) onto the Heck-Pack system (PCA-1266) with the 4 bolts provided;
  - 2) Figure 2: Insert the Heck-Pack on the ball and fasten it down with the lever;
  - 3) Figure 2: Slide the winch support plate (PCA-1268) onto the square tubing and secure it with both the hitch pin and the "R" pin;
- Note:** Its lateral movement can be adjusted by positioning the bolts into the square holes;
- 4) Attach the winch anchor hooks to the eye bolts (as shown in section 3.3.3);
  - 5) Wrap the rope around the drum and start winching. The winch will align itself automatically with the load.

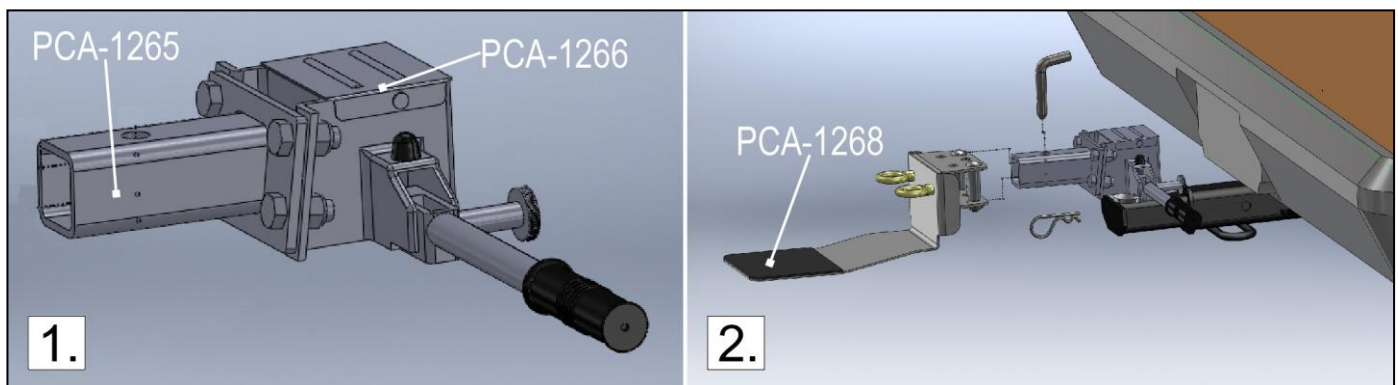

**⚠ CAUTION** IF YOU NEED TO PULL DOWNWARD, YOU WILL NEED TO INSTALL EITHER A PULLEY OR A ROLLER TO PREVENT DAMAGE TO THE WINCH SUPPORT PLATE.

**⚠ CAUTION** MAKE SURE THE ANCHORING VEHICLE'S HAND BRAKE IS ON AND WORKING PROPERLY. POSITION BLOCKS BEHIND THE WHEELS TO PREVENT ROLL BACK.

### **3.3.5 Using the tree/pole mount with anchor strap (PCA-1263)**

The tree/pole mount is intended to use with either the winch support plate (PCA-1268) or the vertical pull winch support (PCA-1264). Therefore, you must first install the tree/pole mount. To do this, follow these steps:

- 1) Figure 1: Place the tree/pole mount at the base of the tree or pole. Insert the sling's hook into the anchor point on the left; then feed the sling's end through the ratchet system;
- 2) Figure 2: Slide the whole set-up upward to the desired height and remove the supplied wrench;
- 3) Figure 3: Tighten the sling with the wrench while making sure the rubber pads are properly positioned. The pads should offer maximum contact surface with the tree or pole.

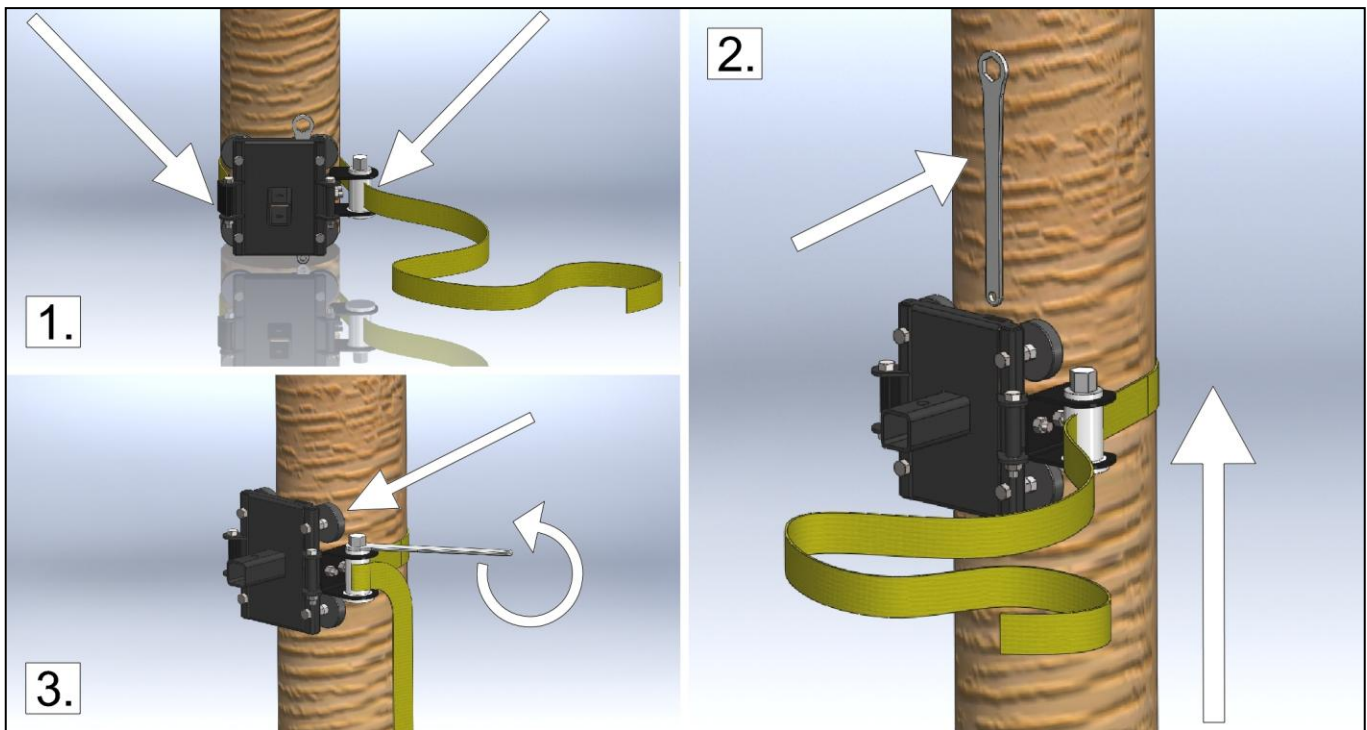

### **3.3.5.1 With the winch support plate (PCA-1268)**

After the installation of the tree/pole mount (section 3.3.5), follow these steps:

- 1) Figure 1: Insert the winch support plate onto the square tubing of the tree/pole mount (PCA-1263) and fasten it down with the hitch pin and “R” pin;
- 2) Figure 2: Attach the winch anchor hooks to the eye bolts of the winch support plate;
- 3) Figure 3: Wrap the rope around the drum and start winching. The winch will align itself automatically with the load.

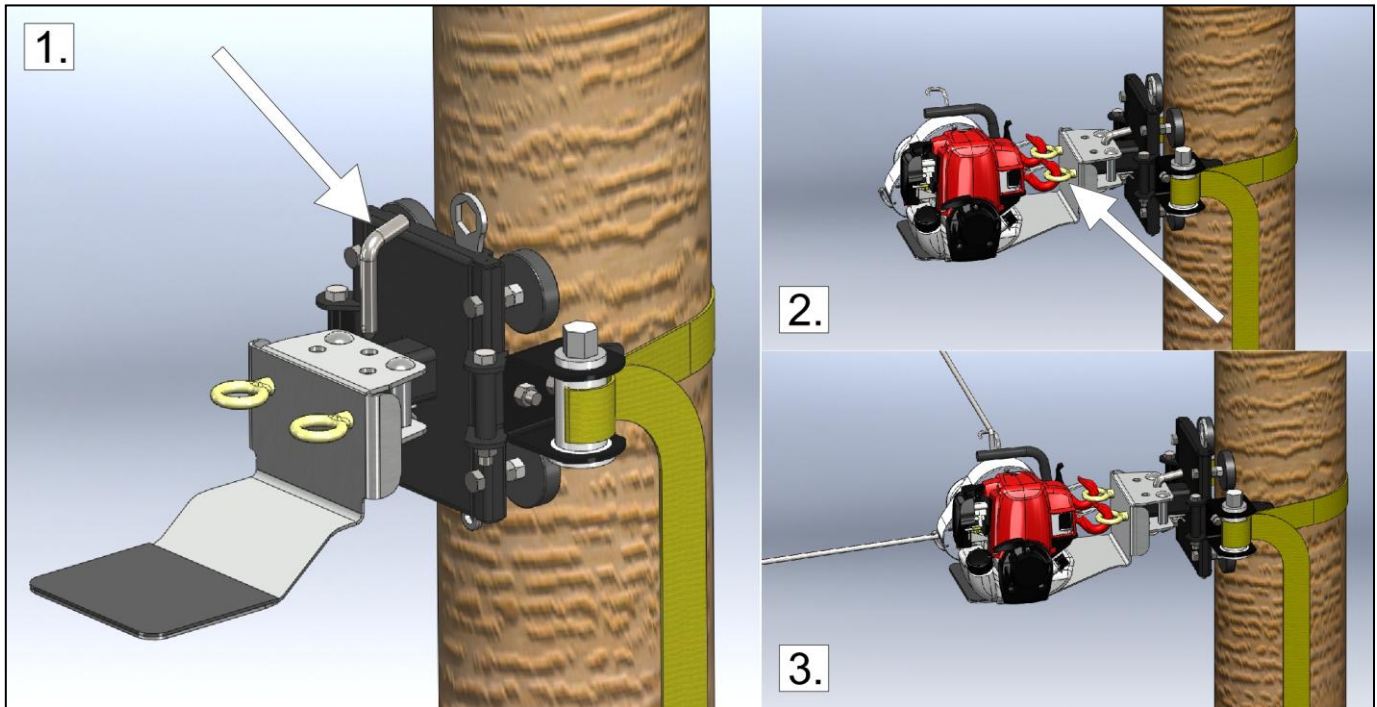

**⚠ CAUTION** IF YOU NEED TO PULL DOWNWARD, YOU WILL NEED TO INSTALL EITHER A PULLEY OR A ROLLER TO PREVENT DAMAGE TO THE WINCH SUPPORT PLATE.

**⚠ WARNING** AFTER PULLING FOR A FEW SECONDS WITH THE TREE/POLE MOUNT, RELEASE THE TENSION OFF THE *PORTABLE CAPSTAN WINCH™*. CHECK THE SOLIDITY OF THE INSTALLATION AND TIGHTEN THE SLING AGAIN.

### **3.3.5.2 With the vertical pull winch support (PCA-1264)**

After the installation of the tree/pole mount (section 3.3.5), follow these steps:

- 1) Figure 1: Insert the vertical pull winch support onto the square tubing of the tree/pole mount (PCA-1263), align the holes and insert the pulley;
- 2) Figure 2: Tighten the nut with your fingers until it touches the support. Then reinforce it with the “R” pin;
- 3) Figure 3: Attach the winch anchor hooks to the eye bolts of the vertical pull winch support;
- 4) Figure 4: Wrap the rope around the drum and align the vertical support pulley with the rope axe and start to pull;

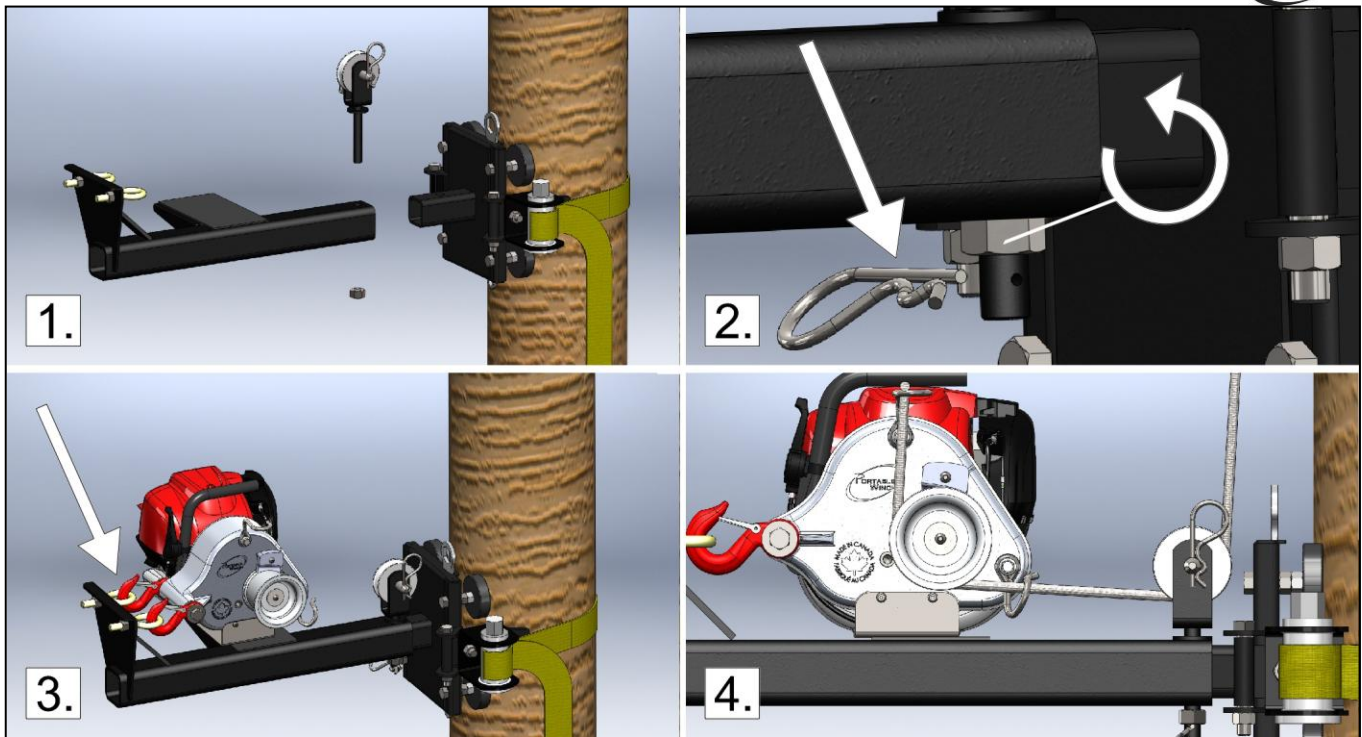

**⚠ WARNING** THE *PORTABLE CAPSTAN WINCH™* IS NOT INTENDED FOR LIFTING PURPOSES.

**⚠ WARNING** IMPORTANT: AFTER PULLING FOR A FEW SECONDS, RELEASE THE TENSION AND CHECK THE SOLIDITY OF THE INSTALLATION AND TIGHTEN THE SLING OF THE TREE/POLE MOUNT AGAIN.

### **3.4 Rope installation**

**⚠ WARNING** USING COMMON SENSE WHILE INSTALLING THE ROPE IS THE KEY TO A SECURE WINCH USAGE.

The great variety of situations encountered when winching prevents us from providing specific instructions; however you need to consider the following points:

#### **3.4.1 Rope**

Use a low stretch rope, in good condition, with a minimum diameter of 10 mm (3/8") and a maximum diameter of 12-13 mm (1/2"), with good knots. We strongly suggest the bowline knot (see section 3.2.1). Use pulleys to redirect the rope and to multiply the pulling capacity when the load is near or over the pulling capacity of the winch.

#### **3.4.2 Pulley**

Using a pulley at some distance in front of the winch offers many advantages:

- Pulling angle 'lifts' the load and reduces friction;
- The winch is maintained at a relatively horizontal position;
- Winch and operator are away from the load's path.

### 3.4.3 Direction

Install the rope in such a way that it does not rub against other objects. Try to set-up the rope so that the front of the load is slightly lifted. Do not pull downwards or through an obstruction.

**⚠ Generally, if the rope touches the ground while pulling, your installation is incorrect.**

### 3.4.4 On a hill

**⚠ WARNING** DO NOT PULL A LOAD DIRECTLY TOWARD THE WINCH IN A DOWNWARD SLOPE SINCE IT COULD SLIDE WITHOUT YOU BEING ABLE TO STOP IT. IN THAT SITUATION, USE A PULLEY AT THE BOTTOM OF THE HILL AND POSITION THE WINCH OUTSIDE OF THE LOAD'S PATH.

### 3.5 Pulling a load

**⚠ WARNING** CHECK WINCH POSITION, ROPE CONDITION, SOLIDITY OF THE ANCHOR POINT, KNOTS, CARABINERS OR SHACKLES IN ORDER TO PREVENT INJURIES OR MATERIAL DAMAGE.

#### 3.5.1 Wrapping the rope on the capstan drum

**⚠ WARNING** NEVER PUT YOUR HANDS ON THE CAPSTAN DRUM, THE ROPE GUIDE OR THE ROPE ENTRY HOOK WHEN THE ENGINE IS RUNNING.

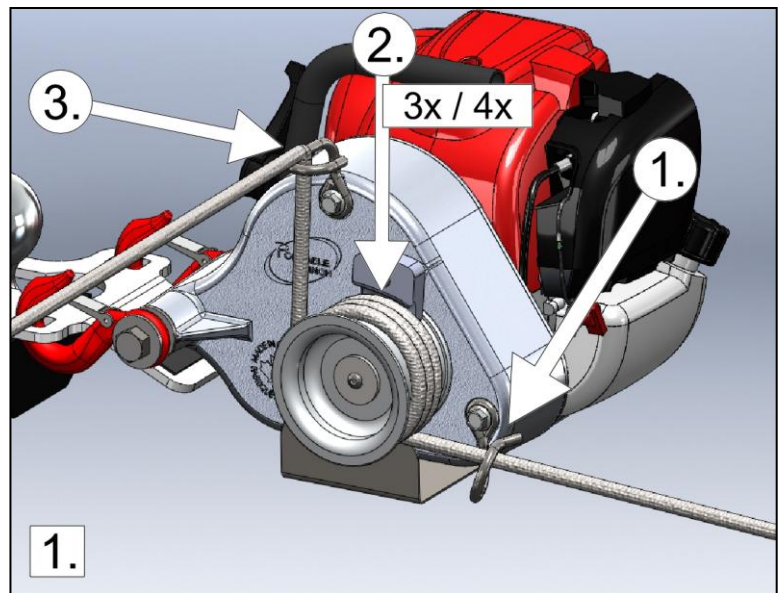

- 1) Start the engine and let it idle for 30 seconds to warm-up;
- 2) Run the rope into the rope entry hook and under the drum (figure 1, no. 1);
- 3) Wrap the rope around the drum (3 or 4 turns) (figure 1, no. 2);
- 4) Bring the rope in the rope exit hook (figure 1, no. 3);
- 5) Stand about 1 m (3') from the winch and pull gently and horizontally on the rope to get the slack until you feel the tension rising on the rope;
- 6) Look at your set-up to make sure that the winch anchor and the rope entry hook are aligned with the rope;
- 7) Check that the rope does not rub against objects along the path;
- 8) Pull the throttle up and start winching.

### **3.5.2 Winching**

While winching, position yourself away from the winch in order to see both the winch and the load. Pull **HORIZONTALLY** on the rope. The tension you exert on the rope will keep the winch level.

**⚠ DANGER** DO NOT WRAP THE ROPE AROUND YOUR HANDS OR YOUR BODY! ALSO BEWARE OF THE ROPE ACCUMULATING IN FRONT OF YOU; MAKE SURE YOUR FEET DO NOT GET TANGLED IN IT.

**⚠ WARNING** CAREFULLY WATCH THE CAPSTAN DRUM DURING THE OPERATION AND MAKE SURE THAT THE ROPE DOES NOT CROSS OVER ON IT. IF IT HAPPENS, RELEASE THE TENSION ON THE ROPE AND STOP THE ENGINE WHILE UNDOING THE CROSS OVER.

#### **3.5.2.1 If the rope slips**

If the rope slips on the drum while winching, add a fourth wrap of rope on the drum. When the winch reaches its maximum capacity, the engine stalls. You then have to redo your set-up (add pulleys) or "rock" the load (see section 3.5.2.2).

#### **3.5.2.2 To "rock" the load**

Pull the rope until the engine comes close to stalling and release the tension. Pull again on the rope to put tension and repeat as needed.

**⚠ CAUTION** BE CAREFUL WITH THIS METHOD SINCE IT GENERATES HEAT AND CAN WEAR THE ROPE QUICKLY.

**⚠ WARNING** IF THE WINCH IS PULLING THE ROPE BUT THE LOAD DOES NOT MOVE (OFTEN THE CASE WHEN USING A VERY LONG ROPE), IT'S BECAUSE YOUR ROPE IS STRETCHING AND COULD REACH THE BREAKING POINT AND RECOIL TOWARDS YOU. SLOWLY RELEASE THE TENSION ON THE ROPE BUT BEWARE OF THE ACCUMULATED TENSION. YOU COULD GET BURNED FROM THE ROPE EXITING YOUR HANDS QUICKLY OR BE PULLED TOWARDS THE WINCH.

#### **3.5.2.3 How to pause while winching**

**SLOWLY** release the tension on the rope and let it slip on the capstan drum.

**⚠ CAUTION** DO NOT LET THE ROPE SLIP FOR MORE THAN A FEW SECONDS ON THE DRUM WHILE IN TENSION – THE HEAT CREATED BY THE FRICTION COULD MELT OR DAMAGE THE ROPE.

### 3.5.2.4 If your rope is too short

If your rope is too short, you will have to link two ropes together:

- 1) Figure 1, no. 1: Using the bowline knot (section 3.2.1), link your two ropes together;
- 2) Figure 1, no. 2: **IMPORTANT:** Leave about 1 m (3') of rope tailing out of the knot on the rope holding the load. You will need it to resume winching after undoing the knots;
- 3) Figure 2, no. 1: Stop the winch **BEFORE** the knot reaches the rope entry hook of the winch since it **CANNOT GO THROUGH** it;
- 4) Release tension off the rope. If necessary, attach the load to a fixed object;
- 5) Undo the knots and use the remaining length (1 m or 3') of the second rope to wrap around the capstan drum and start winching again.

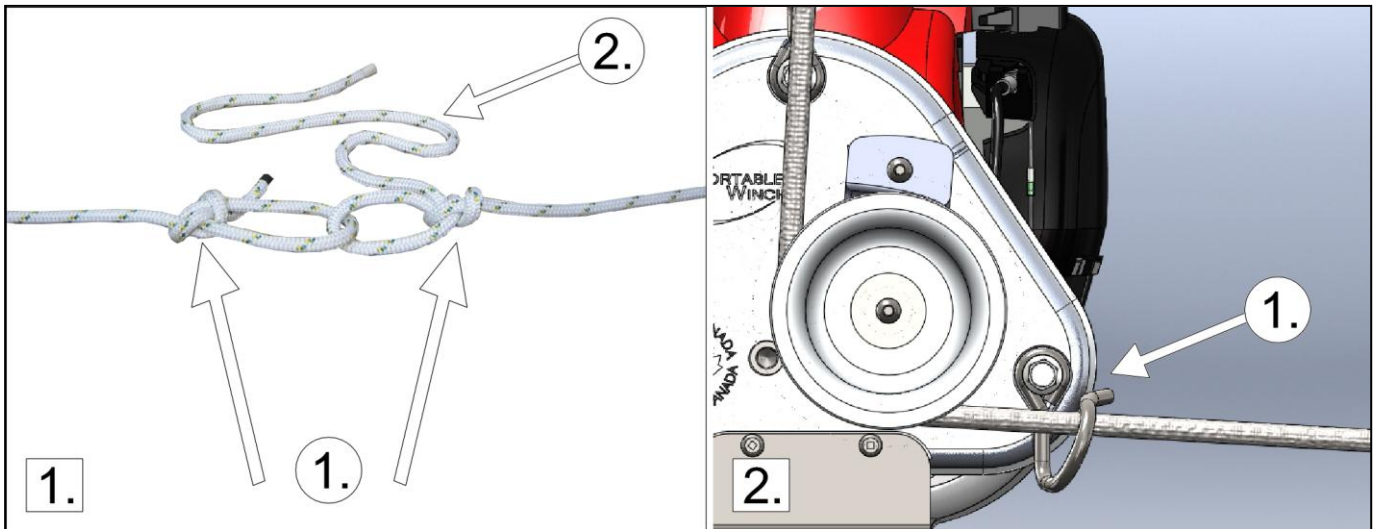

### 3.5.3 Stopping the winch

- 1) Release tension gradually to lower the winch gently to the ground;
- 2) Bring throttle down to idle;
- 3) Turn ignition switch off.

## 4.0 Maintenance

### 4.1 Cleaning

Once your job is done, you should clean and dry your winch.

**CAUTION** INSPECT THE WINCH, HOOKS, ROPE, KNOTS AND POLYESTER SLING TO DETECT ANY DAMAGE OR SIGNS OF WEAR.

Periodically, remove the capstan drum and clean around the shaft (figure 1). Accumulated debris can damage the shaft seal. Apply oil to prevent corrosion.

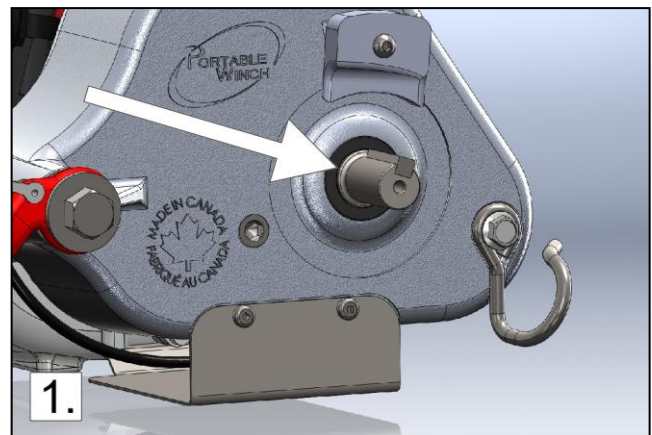

## **4.2 Lubrication**

The gearbox is lubricated at the factory and should not require additional lubrication or maintenance. If there is appearance of a leak, check oil level by placing the winch on a level surface and remove the oil plug (figure 1). Use an 8 mm hex key.

Lean it toward you; some oil should leak out of the hole. If needed, you can add type SAE80W90EP gear box oil.

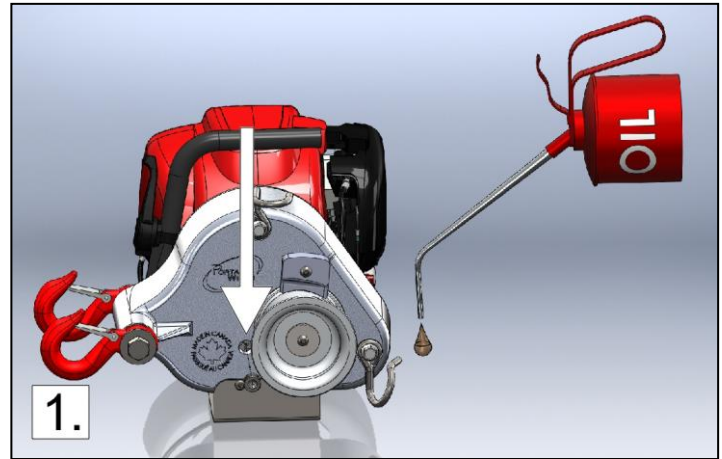

## **4.3 Honda engine**

Maintain the engine according to the instructions found in the Honda engine user manual provided.

## **4.4 Storage**

Always store your *Portable Capstan Winch™* seated on its protection plate. Refer to the Honda engine user manual for engine storage instructions.

## **4.5 Spark arrestor**

Since your *Portable Capstan Winch™* is equipped with the optional spark arrestor, you must clean it every one hundred (100) hours. Refer to the Honda engine user manual for cleaning instructions.

## **5.0 Complementary information**

### **5.1 Accessories**

A complete line of accessories is available. You will find the list on our website at [www.portablewinch.com](http://www.portablewinch.com).

## **5.2 Warranty**

Portable Winch Co. products are warranted against defects in materials and workmanship while owned by the "*original purchaser*" as defined below.

The "*original purchaser*" is defined as the party or entity which purchases the winch and/or accessories from an authorized Portable Winch Co. retailer as shown by the original sales receipt. The warranty ownership is transferable, provided the end-user has a copy of the original purchaser's invoice. This warranty does not apply to "*wear parts*" defined as being in contact with the rope while winching.

The PCW3000 *Portable Capstan Winch* is covered as follows:

- Winch components:
  - Private use: One (1) year warranty (service by Portable Winch Co. and/or its retailers);
  - Commercial use: Three (3) months warranty (service by Portable Winch Co. and/or its retailers);
- Engine: The Honda engine is warranted by Honda Motor Corporation and the duration varies according to country and usage. All Honda service centers can repair the winch engine under warranty. Hang on to your proof of purchase (invoice with serial number). It will be used to establish the beginning of the warranty period.

Portable Winch Co. will replace or repair, at its option, any defective product. All other *Portable Winch™* accessories are covered by a complete one (1) year warranty. Please refer to the Portable Winch Co. complete warranty on [www.portablewinch.com](http://www.portablewinch.com) if you have any questions.

### **Extend your warranty for free**

We would like to thank you for your purchase. By doing so we would like to offer you ONE (1) EXTRA YEAR WARRANTY for FREE! It's simple, simply register your winch on [www.portablewinch.com](http://www.portablewinch.com) or by phone at 1-888-388-PULL (7855) or +1 819 563-2193.

## **5.3 Serial number localization**

The winch serial number is indicated on the safety warning label located on the right side of the winch housing and is also engraved on the cover of the winch, to the left of the capstan drum.

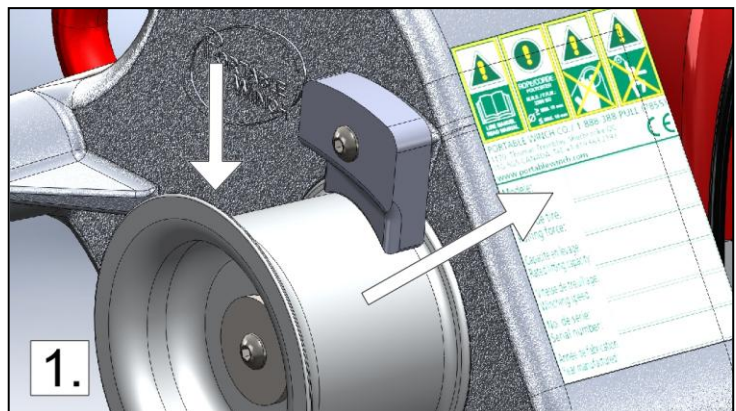

5.4 CE Declaration of conformity



**DECLARATION OF CONFORMITY**

We  
of

**PORTABLE WINCH CO.**  
1170 Thomas-Tremblay St.  
Sherbrooke, QC J1G 5G5  
CANADA  
Tel: +1 819 563-2193  
www.portablewinch.com

Declare that the product

**Portable Capstan Winch**  
Model PCW3000

For intended purpose

Pulling non-rolling objects at angles  $\pm 45^\circ$  from  
horizontal plane

Fulfills all relevant provisions of Machinery Directive 2006/42/EC

And also fulfills all relevant provisions of

- 2004/108/EC      Electromagnetic Compatibility Directive

Mr. Gerold Vonblon,  
Landstrasse 28, A-6714 Nuziders  
Is authorized to compile the technical file.

Signed by:



Name: Pierre Roy  
Position: Managing Director



Done at Sherbrooke, QC, Canada  
On April 18<sup>th</sup>, 2012.



ITEM NO.	PART NUMBER	DESCRIPTION	QTY
1	31-0010	HCS 1/2-13 X 6 - GR5 - ZN	1
2	35-0004	FLAT WASHER 1/2 - ZN	4
3	10-0098	BUSHING FOR SAFETY HOOK	2
4	PCA-1281	SAFETY HOOK 3/4 TON	2
5	32-0008	HEX FLANGE SERRATED BOLT M8-1.25 X 16MM - ZN	2
6	10-0135	ROPE EXIT HOOK	1
7	32-0004	BHCS M6-1 X 16 MM - SS	9
8	10-0131	ROPE GUIDE FOR CAPSTAN DRUM 76 MM	1
9	10-0137	WINCH HANDLE (PCW3000)	1
10	44-0002	THROTTLE LEVER	1
11	10-0134	THROTTLE CABLE ASSEMBLY	1
12	33-0005	NYLON LOCKNUT 1/2-13 - ZN	1
13	32-0009	SHCS M5-0.8 X 10MM	1
14	45-0002	ON/OFF SWITCH (PCW3000)	1
15	10-0130	GUARD PLATE (PCW3000)	1
16	39-0007	METAL SCREW #10 X 1/2 - ZN	4
17	10-0136	ROPE ENTRY HOOK	1
18	10-0129	CAPSTAN DRUM 76 MM	1
	43-0023	SHAFT KEY FOR CAPSTAN DRUM 76 MM	1
19	10-0102	DRUM RETAINING WASHER	1
20	44-0001	UNIVERSAL SERIAL NUMBER & WARNING LABEL	1
21	44-0025	ROPE INSTALLATION LABEL PCW3000	1
22	44-0023	DECIBEL WARNING 93 dB LABEL	1

## **5.6 Technical data**

- Engine: 4-stroke all positions Honda GX-35 cc
- Maximum pulling force (single line): 700 kg (1550lb)
- Speed: 8 m/min (26 ft/min)
- Capstan drum: 76 mm (3") diameter
  - Up to 4 wraps of 10 mm (3/8") rope
- Gear box: Aluminum alloy; Gear ratio 200:1
- Unit weight: 9,5 kg (20 lb)
- Dimensions (overall): 35 cm Length x 29 cm Width x 26 cm Height (13-3/4" x 11-3/8" x 10-1/8")
- Rope: Double braided polyester (not included) – Unlimited rope length
  - Minimum diameter: 10 mm (3/8")
  - Maximum diameter: 12-13 mm (1/2")



## **5.7 Manufacturer**

The *Portable Capstan Winches* are manufactured by:

**Portable Winch Co.**

1170, Thomas-Tremblay Street

Sherbrooke, Quebec, J1G 5G5

CANADA

Phone: +1 819 563-2193

Toll free (Canada & USA): 1-888-388-PULL (7855)

Fax: +1 514 227-5196 - Email: [info@portablewinch.com](mailto:info@portablewinch.com) - [www.portablewinch.com](http://www.portablewinch.com)