



M296020Q

MODEL NUMBER: 296020

SERIAL NUMBER: _____

Owner's Manual

Instructions for Operation, Maintenance

Stump and Root Grinder

Your NorthStar grinder is intended for outdoor-use only and can be used to remove many tree stumps and exposed root systems close to ground level. By moving the wheel in sweeping movements laterally over the top and front of the stump, you can gradually grind it away. Make sure you completely read and understand this manual before using the grinder for the first time.

⚠ WARNING

READ and UNDERSTAND this manual completely before using the grinder! Failure to properly operate, and maintain this grinder could result in *serious injury or death* to the operator or bystanders.

All machines have hazards associated with their operation. This stump grinder has certain special hazards, which you must be aware of. As an operator or owner you have a duty to be aware of these hazards and know preventive measures to take to avoid them. When reading this manual pay particular attention to avoiding these hazards.

In particular, be aware of the following:

- **Know location of buried electrical and other utility lines.**
- **Do not allow children or untrained adults to operate.**
- **Wear eye protection and other personal protection against flying rocks and debris.**
- **Check that cutter wheel teeth are secured, sharp and not missing.**
- **Do not operate if operator presence bar fails to stop engine upon release.**
- **Make sure no children or bystanders are within 75' (feet) of stump grinding operation.**
- **Protect cars, windows and other objects within 75' from flying debris.**
- **Be prepared for machine “kickback” when initially contacting the stump.**
- **Be aware of potential for carbon monoxide (CO) poisoning.**
- **Prevent fires/explosions from fueling.**
- **Do not attempt to perform adjustments, declog or clean unit while engine is running.**
- **Avoid burns from engine or hot exhaust.**
- **Avoid using in wet or icy conditions where falls may occur.**

Details about these hazards are found throughout the manual and are summarized at the end of the manual under “Important Safety Information.”

STOP!

ADD ENGINE OIL: Your stump grinder comes fully assembled and requires only that you add engine oil to crankcase and fuel to tank.

INSPECT COMPONENTS: Closely inspect to make sure no components are missing or damaged. See the “Receiving Your Unit” section for instructions on whom to contact to report missing or damaged parts.

Any Questions, Comments, Problems, or Parts Orders
Call your dealer or NorthStar Product Support 1-800-270-0810

Hazard Signal Word Definitions





	<p>This is the safety alert symbol. It is used to alert you to potential personal injury hazards. Obey all safety messages that follow this symbol to avoid possible injury or death.</p>
	<p>DANGER (red) indicates an imminently hazardous situation which, if not avoided, will result in death or serious injury.</p>
	<p>WARNING (orange) indicates a potentially hazardous situation which, if not avoided, could result in death or serious injury.</p>
	<p>CAUTION (yellow) indicates a potentially hazardous situation which, if not avoided, may result in minor or moderate injury.</p>
	<p>CAUTION (yellow) used without the safety alert symbol indicates a potentially hazardous situation which, if not avoided, may result in property damage.</p>

fig01453

Table of Contents

Part I. Introduction

About Your Grinder	4
Safety Decal Locations	5
Safety Decals	6
Transporting & Receiving:	
1. Receiving Your Unit	7
2. Towing Instructions	7
Machine Component Identification	8

Part II. Operation

Operation:	
1. Pre-Start Check List & Procedures	9
2. Starting the Grinder	11
3. Stopping Engine	13
4. Grinding Stump	13
5. Refueling	15
6. Storing Machine	16

Part III. Maintenance and Repair

Maintenance (To be done by owner or rental dealer)	18
1. Belt Tension Adjustment	20
2. Stop-Switch Adjustment	21
3. Setting & Sharpening Teeth	21
4. Schedule	24
Specifications	25

Part IV: Important Safety Information

Summary of Important Safety Information for Operation	26
Special Safety Information on Static Electricity	29

Parts Explosion	30
------------------------------	----

Wiring Diagram	32
-----------------------------	----

Warranty	33
-----------------------	----

California Proposition 65 Information	34
----------------------------------------------------	----

About Your Grinder

Thank you for purchasing or renting your NorthStar grinder!

Owner/Operator/Renter Training

Read and follow all instructions and safety precautions presented throughout this manual. A summary of important safety information can be found at the end of the manual. Keep this manual for reference and review. **If the owner of this unit is different than the operator, give a copy of this manual to any operator to read.**

Rental Companies

All persons to whom you rent/loan this grinder must have access to this manual and read it. Check the tube on the side of the unit to make sure a manual is inside. Advise all persons who will operate the machine to read it. You should also provide personal instruction on how to safely operate the grinder and remain available to answer any questions a renter/borrower might have. If videos are available, have renter watch training video.

Engine Instructions

For detailed Engine operation and maintenance information, always refer to the engine Owner's Manual furnished with the grinder.

Product Suitability

Before using, the user shall determine the suitability of this product for this intended use and assumes liability therein.

Your NorthStar grinder can be used to remove many tree stumps and exposed root systems close to ground level. By moving the wheel in sweeping movements laterally over the top and front of the stump, you can gradually grind it away. Make sure you completely read and understand this manual before using the grinder for the first time. If you have any questions, contact your retail or rental dealer or NorthStar Product Support at 1-800-270-0810.

▲ WARNING: Never attempt to cut on a slope exceeding 15°.

Exercise caution when cutting stumps on an incline, as the machine may shift or slide unpredictably. Never attempt to cut with the machine uphill or downhill from you as it may slide toward you or you may fall toward the machine. Cut only on a slope from the side.

NorthStar is constantly improving its products. The specifications outlined herein are subject to change without prior notice or obligation. The purchaser and/or user shall assume liability for any modification and/or alterations of this equipment from original design and manufacture.

Contact NorthStar Product Support at 1-800-270-0810 for any questions about the appropriate use of this grinder or about optional accessories.

Warranty Registration

Please fill out and submit the warranty registration card so that we have your contact information for any future product literature or replacement parts you may need.

Safety Decal Locations

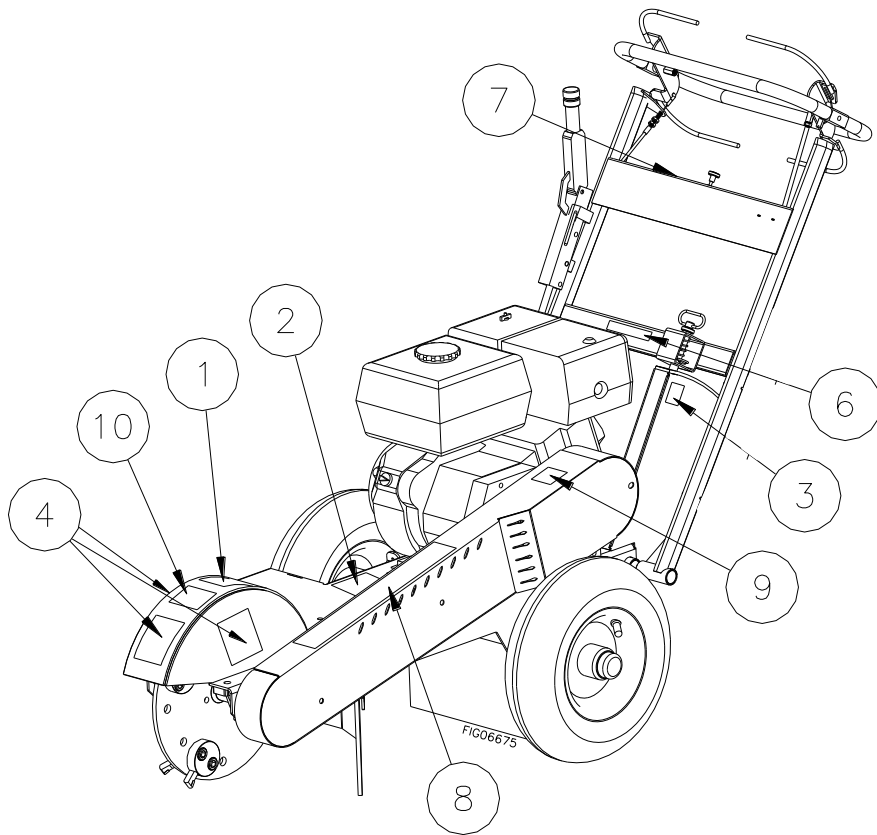

Reference #	Part #	Description
2	784291	Flying Debris Hazard (direction)
3	784079	Tow Position
7	783540	Control Panel
1	799611 decal kit	Flying Debris Hazard (person)
4		Amputation and Entanglement Hazard
--		---
6		Poisonous Gas Hazard
8		Personal Injury / Fire, Explosion / Entanglement Hazards
9	786635	Burn Hazard
10	799952	Spark-Strike Warning

⚠ WARNING

ALWAYS make sure safety labels are in place and in good condition. If a safety label is missing or not legible, order new labels.

Safety Decals

CAUTION		WARNING	
Personal Injury Hazard Never attempt to use this machine without proper personal protection. When using this machine, you must wear the following: • Eye protection • Ear and hearing protection • Heavy duty work gloves • Heavy duty, tight fitting clothing		Fire / Explosion Hazard Gasoline is highly flammable and explosive. - NEVER fuel a running or hot engine. - ALWAYS turn engine off and let cool for at least two minutes before refueling. - Clean up fuel spills immediately. - Ensure there are no fuel leaks before starting. - DO NOT pump fuel directly into engine at gas station.	
Entanglement Hazard NEVER remove guards or shields. NEVER operate this machine when wearing loose clothing, scarves, or gloves with large loose cuffs or flaps. ONLY operate with proper guarding of power transmission system, including all rotating shafts, pulleys, belts, and couplings.		Fire Hazard Hot exhaust fumes from engine can cause fire. Position muffler at least 7feet from combustible objects, including vegetation and clothing. Do not change or add to exhaust system, fuel tanks, or fuel lines. Fire can result.	

8

Precautions Before Starting:

1. Check gas and oil levels.
2. If unfamiliar with operation, training information (an Operator's Manual) can be obtained from your rental firm. Your rental firm may also have a video which demonstrates proper use.
3. Wear eye, face, and hearing protection as well as long pants and non-slip footwear.
4. Call 811 for utility marking 3 days before stump grinding. Trees can grow on top of & around utility lines.
5. Use of the stump grinder requires considerable strength and endurance. It should be operated only by an adult who has adequate physical capability.
6. Keep children away.
7. Replace worn or unrecognizable labels.

ENGINE SWITCH

PUSH TO STOP

PULL TO RUN

SPECIAL Operator Hazards:

1. Read & follow operator's manual before using.
2. Before adding fuel, stop the engine. Allow engine to cool for 5 minutes before refueling.
3. Do not pump fuel directly into engine at gas station.
4. Blows created at speeds similar to a rotary lawn mower can cause serious injury. Do not operate 75 ft away from windows, autos or any object which might be damaged by the rock type projectiles the machine will throw.
5. Never operate without shields and covers in place.

10 Start Your Stump Grinder:

1. Pull Engine Switch to RUN position.
2. Put cold engine cover back over fuel filler to half choke or to RUN position.
3. Grip Operator presence Bar & handle together in front of the engine.
4. Turn the key switch to the START position and hold until the engine starts.
5. Release the key switch after 5 seconds wait 10 seconds before attempting to start again.
6. Release the key when the engine starts.
7. When engine starts, move CHOKE lever to RUN position.

BRAKE LEVER

OFF ON

KEEP BRAKE ENGAGED
 (except when changing locations, STOP engine & SET Brake before leaving operator's position)

7

WARNING

Poisonous Gas Hazard

This product gives off carbon monoxide, a poisonous gas that can kill you.

- NEVER use in enclosed spaces EVEN if you run a fan or open doors and windows.
- Only use OUTSIDE and far away from windows, doors, and vents.

See product manual for more details.

10

WARNING

FIRE HAZARD

Sparks can occur if flammable strikes rocks, Do NOT use in high/very high fire hazard severity zones.
 -Operation of this equipment may create sparks which may be sufficient to ignite nearby combustibles. Contact local fire agencies for laws and regulations relating to fire prevention requirements.

1

WARNING

Flying Debris Hazard

Flying debris can travel up to 75 feet.
 Flying debris can also bounce off of this shield and the nearby objects.
 NEVER allow anyone in DANGER ZONE while grinding.
 ALWAYS position machine to protect property (such as buildings and vehicles) from flying debris.
 Rubber shielding is intended to direct discharge to protect operator's lower extremities.
 Wear long pants and closed shoes, as well as eye and face protection.
 Replaces if shielding is worn or damaged.

2

WARNING

Flying Debris Hazard

Stones, chips, and debris can cause serious injury or property damage.
 Primary chip discharge is in the direction of the arrow.
 However debris can fly 75 ft in any direction out the chute and bounce off objects and the operator or bystanders.

3

Towing and Transport Position

4

WARNING

Amputation & Entanglement Hazard

Rotating Cutter

Keep hands and feet away.
 Contact with rotating teeth will cause serious personal injury.
 NEVER operate without guards and covers in place.

9

WARNING

BURN HAZARD

Do not touch hot muffler.

To order replacement safety labels, call NorthStar Product Support at 1-800-270-0810. All grinder units can be transported via trailers or with the purchase of an optional towing kit package can be towed behind the vehicle.

Transporting and Receiving

1. Receiving Your Unit

For all Units	<p>You should inspect the grinder immediately after you receive delivery. See the “Machine Component Identification” section of this manual for a diagram of the grinder and its components.</p> <p>If you have missing or damaged components, please contact NorthStar Product Support at 1-800-270-0810.</p>
New Unit: Truck Delivery	<p>Depending on your unit and model, it may have been shipped on a wooden skid, cardboard container or other appropriate method.</p> <p>◆ If any assembly is required. Separate assembly instructions will be included.</p>
New Unit: From a Dealer	<p>Your unit should have been delivered completely assembled and ready to run. Read the “Operation: Preparing for Operation” section (page 9), and verify that the unit has been properly “prepped” before initial use.</p>
Factory Delivery	<p>In these cases, your unit has been completely assembled, tested and pre-run. It should be ready for usage. See “Pre-Start Checklist and Procedures”.</p>

2. Towing Instructions

<p>On Towable Models</p> <p>Optional tow package: Item # 296022</p>	<p>Each state has legal requirements for towing equipment and trailers (such as lighting and licensing). Be sure receiver on towing vehicle is bolted tightly. Towing vehicle capability must be matched to trailer weight and type of hitch arrangement.</p> <ol style="list-style-type: none"> 1. Review towing safety instructions in your vehicle manual. 2. Attach grinder to vehicle hitch using only a 2" ball. 3. Be sure the tow bar is bolted tightly to the towing vehicle receiver. 4. Position tow bar into socket, then insert lock pin with safety clip. 5. Be sure that the stump grinder safety chains are hooked, closed and locked to the towing vehicle by using the coupling links. 6. Make sure the grinder wheel lug nuts are fastened tightly, tires are fully inflated and in good repair. <div style="background-color: #e0e0e0; padding: 5px; margin-top: 10px;"> <p>⚠ WARNING: Do not tow over 45 mph unless a higher speed rated trailer is being used.</p> </div>
---------------------------------------------------------------------------------------	------------------------------------------------------------------------------------------------------------------------------------------------------------------------------------------------------------------------------------------------------------------------------------------------------------------------------------------------------------------------------------------------------------------------------------------------------------------------------------------------------------------------------------------------------------------------------------------------------------------------------------------------------------------------------------------------------------------------------------------------------------------------------------------------------------------------------------------------------------------------------------------------------------------------------------------------------------------------------------------------------------------------------------------------------------------------

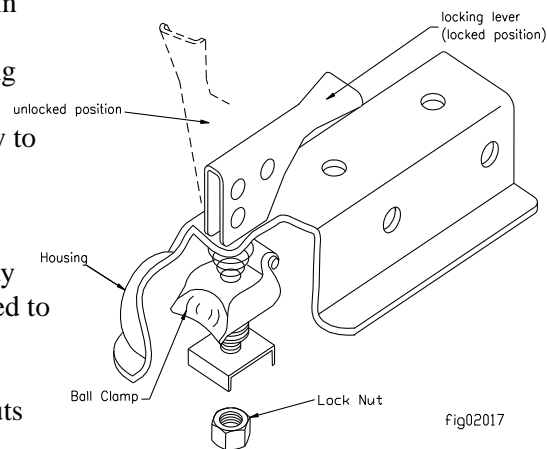

Machine Component Identification

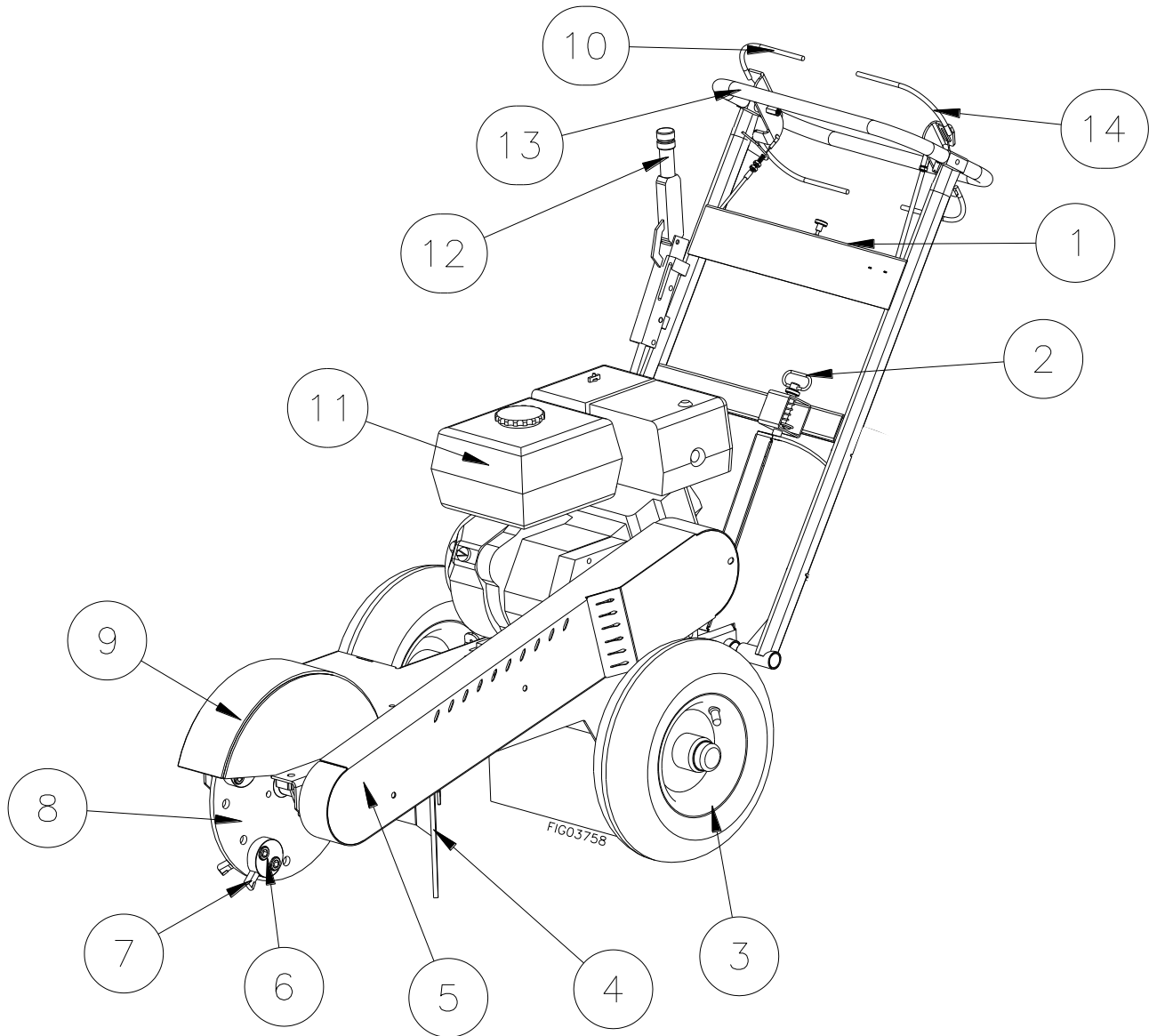

Reference #	Description
1	Control Panel
2	Pin Adjustment Handle Bar
3	Tire and Hub
4	Discharge Flap
5	Belt Guard
6	Tooth Pocket
7	Cutting Tooth
8	Cutter Wheel Disc
9	Cutter Guard
10	Throttle Control Lever
11	Engine
12	Adjustable Brake Lever
13	Handle Bar
14	Operator Presence Handle Bar

Operation

1. Pre-start Check List & Procedures

⚠ CAUTION:

Add engine crankcase oil. A new engine is shipped without oil. You must add the correct amount of oil to engine crankcase or engine will be damaged beyond repair.

Before starting the engine you will want to make sure you have completed the following:

1. **Marking Underground Utilities**
2. **Checking Controls**
3. **Checking/Adding Oil**
4. **Filling Stump Grinder Gasoline Tank**
5. **Inspecting Fuel System for Leaks**
6. **Adjusting Handle Bar**
7. **Wearing Personal Protection**
8. **Trimming Stump with Saw**
9. **Clearing Area of People and Objects**
10. **Working During Daylight**

Each of these procedures is discussed in detail below.

Marking Underground Utilities	Call 811 or your local utility company to request marking utilities 3 days before stump grinding. Trees can grow on top of and around underground wiring that was installed many years before a tree was planted.
Check controls.	<p>Check that:</p> <ul style="list-style-type: none"> • All guards are in place and tight • Operator presence bar switch is free moving. • Inspect tires and rims for looseness, damage, and tire inflation.
Check cutting teeth	Inspect cutting teeth for tightness and sharpness. Only use factory-approved parts for repair.
Check/add oil	<p>Check the oil level using the dipstick and add oil as needed daily.</p> <p>Using a funnel, add oil up to the FULL mark on the dipstick with the recommended oil type for your engine and expected ambient conditions. (See engine Owner's Manual for oil type and capacity, and more detailed oil check/fill instructions.)</p> <p>⚠ WARNING: Burn hazard Never open oil fill port while engine is running. Hot oil can spray over face and body.</p>

Operation (cont'd)

<p>Fill stump grinder gasoline tank</p>	<p>Check the gasoline level in the grinder's fuel tank. If needed, fill tank with fresh unleaded gasoline from a portable container, after first reading the warnings and instructions below.</p> <ul style="list-style-type: none"> - Do NOT fill the gas tank to the top. Gasoline may spill when operating on a slope. - Do NOT overfill the gasoline tank. Allow at least 1" of empty space below the fill neck to allow for fuel expansion. <p>⚠WARNING: Gasoline fire/explosion hazard Gasoline is highly flammable and explosive. Heat, sparks, and flames can ignite gasoline vapors, which can become widespread during fueling. A flash fire ignition and/or explosion could result and cause serious injury or death. The following conditions could result in gasoline ignition/explosion:</p> <ul style="list-style-type: none"> • gas vapor collection inside enclosures • static electric sparks • sparks from electric wiring, batteries, or running engines • sources of heat (such as a hot engine or exhaust) • open flames, including pilot lights
<p>Inspect Fuel System / Check for Leaks</p>	<p>Inspect fuel system & check for leaks BEFORE starting grinder.</p> <p>⚠WARNING: Fuel leak hazard A leaking fuel line no matter how small can be the source of a fire or explosion when starting or operating the engine.</p> <ul style="list-style-type: none"> • Inspect the entire fuel system. <i>Look for:</i> Signs of leaks or deterioration, chafed or spongy fuel hose, loose connections, loose or missing fuel hose clamps, damaged gasoline tank, or defective gasoline shut-off valve. <p>If grinder is in an enclosed area and you smell gas, DO NOT start engine! DO NOT light a match. DO NOT flip on an electrical switch. Exit area immediately leaving doors open and call fire department.</p>
<p>Adjust Handle Bar</p>	<p>Handle bar may have to be adjusted to accommodate for the height of stump or desired depth. When grinding above or below ground level, adjust handle bar for better control and comfort. <i>Note: Your stump grinder should not be used more than 10 inches maximum below ground</i></p>
<p>Personal Protection</p>	<p>Use approved protective clothing and approved protective equipment when using the machine.</p> <ol style="list-style-type: none"> 1) Always wear ANSI-approved and OSHA-compliant safety glasses with side shields and a full-face shield. 2) The use of ear plugs or other hearing protection device is also recommended for persons working within 15-20 feet of the running grinder for longer than a few minutes. Hearing can be damaged from

Operation (cont'd)

	<p>prolonged, close-range exposure to the type of noise produced by this grinder.</p> <p>3) Wear long pants to protect legs from sparks, hot engine and flying debris.</p> <p>4) Never wear jewelry or loose-fitting clothing when starting or operating the grinder or any mechanical device. Loose or dangling apparel, jewelry or hair can become entangled in moving parts.</p>
Trim Stump with Saw	Cut or trim the stump preferably to ground level using a power saw.
Clear Area	Dig away the earth and remove any stones near the tree stump or roots that may interfere with your work.
Work During Daylight Hours	Only use the machine in daylight or in well-lit conditions. Never operate the grinder after dark.

2. Starting the Grinder

After you have completed the pre-start checklist and procedures, you are ready to start the grinder.

The following directions detail how to start the engine of your grinder.

⚠ WARNING:

Never attempt to use the grinder without proper protective equipment, particularly eye protection and a full-face shield.

To start the grinder:

Note: For additional engine starting instructions see your Honda engine manual.

- 1) Before starting you should raise or lower the handle bar to a comfortable position to accommodate the height of the stump you will be grinding.
- 2) Place stump machine into position with cutting wheel near the front-top edge of the stump.
- 3) Use lever on handle to lock the one wheel brake.

Note: For tighter brake adjustment, turn knob on top of brake lever. (See Maintenance and Repair section for instructions.)

⚠ WARNING:

Stay in the OPERATOR POSITION while actuating controls. Never leave grinder unattended.

- 4) Pull Engine Switches to the ON/RUN position on engine and on the control panel.
- 5) Pull choke if engine is cold. If engine is hot, do not use choke.
- 6) Grip Operator presence bar & Grinder handle bar together in left hand.

Operation (cont'd)

⚠ WARNING:

A rotating cutting wheel is very dangerous. Stay at the controls and keep others away until you are sure the wheel has come to a complete stop.

- 7) Rapidly pull "Start" cord (recoil starter) with right hand several times until engine starts. Allow starter cord to return slowly.
- 8) If engine does not start, repeat steps 5-7.
- 9) Press down handle bar to lift cutter wheel off the ground.
- 10) Grip throttle lever and grinder handle bar together in right hand. Centrifugal clutch will engage and cutter wheel will begin to rotate.

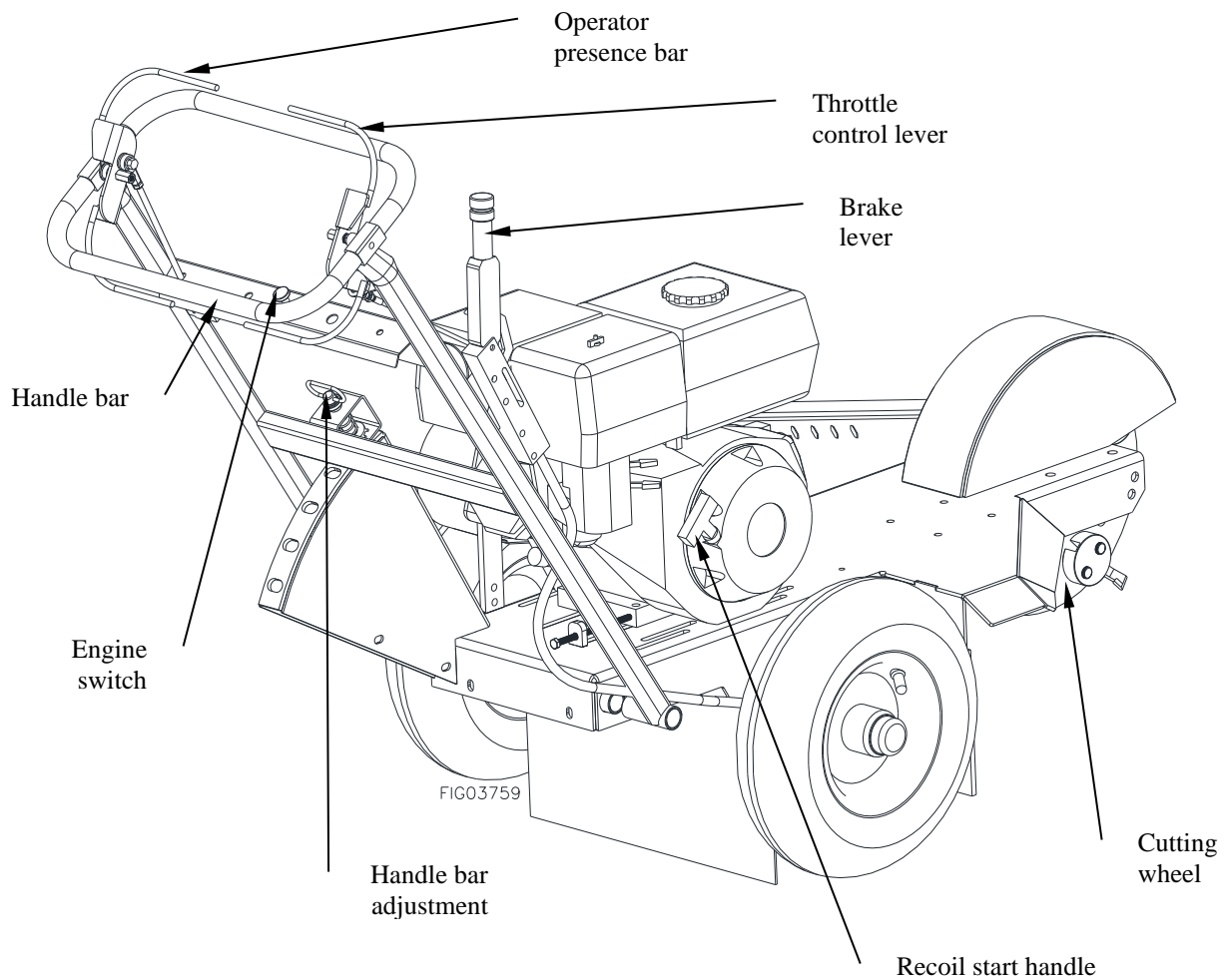

Operation (cont'd)

3. Stopping the Engine

Stop the engine using the following steps:

1. While holding cutting wheel off ground, release the operator presence bar. Wait until the cutting wheel completely stops. Lower the cutting wheel so it is resting against the ground.
2. Make sure brake is set before leaving the controls, particularly if you are on an incline.
3. Turn engine switch to OFF position.
4. Allow the engine to cool for at least 5 minutes before releasing brake and moving to storage or transporting. A hot engine can be a fire hazard.

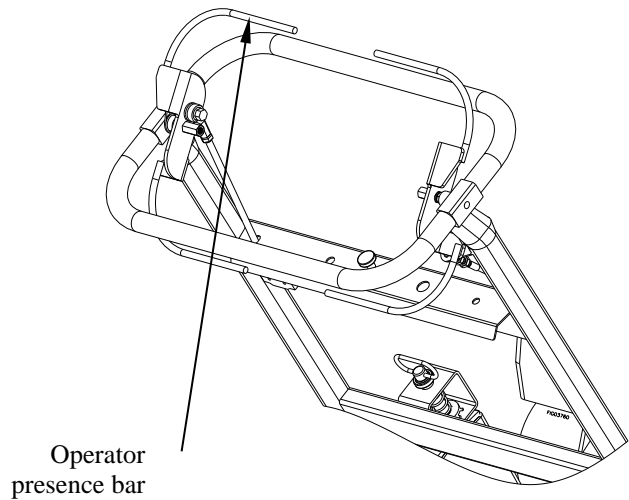

4. Grinding the Stump

⚠ WARNING: Flying Debris Hazard

Stones, chips, and debris can cause serious injury or property damage. Debris can fly 75 ft. in any direction out of the chute. They can bounce off any fixed objects as well and hit operator, bystanders or breakable objects.

1. Set/engage the brake.

Note: Always make sure the cutting teeth are not in contact with anything before operating the throttle lever. Damage can occur to clutch if the cutting wheel is not free to rotate when the throttle is activated.

2. Pivot the grinder toward the side of the stump with the cutter wheel off the ground, and not touching the stump. Hold down throttle control lever and allow the cutting wheel to begin turning. Once the cutting wheel has reached full speed, lower it approximately 1/2" to 1" into the front-top corner of the stump. Slowly pivot the cutting wheel back and forth, lowering the cutting wheel approximately 1/2" to 1" before each sweep, until you have removed the front portion of the stump to ground level.

⚠ WARNING: Rotating cutter wheel.

Keep hands and feet away. Contact with cutter wheel rotating teeth will cause serious personal injury.

Note: If the engine bogs down at any point while grinding, move the cutter wheel away from stump and allow cutter wheel to come back up to full speed before you resume grinding.

3. Raise cutting wheel until center of wheel is just above top of stump.
4. With cutting wheel off to one side, advance the machine horizontally by releasing and resetting the brake. Advance the machine forward to engage the cutting wheel into the stump so that when swept across the stump it will remove 1/2" to 1" of stump with each sweep.

Operation (cont'd)

5. Sweep the cutting wheel across the stump, cutting away 1/2" to 1" of stump.
6. Advance cutting wheel 1/2" to 1", and sweep again across stump in opposite direction.
7. Continue sweeping cutting wheel left and right across stump, advancing it before each sweep, cutting 1/2" to 1" depth of stump with each sweep.
8. Cut complete stump flush with ground, then go back and cut to further depth, if desired.

Chip Build-up

9. When grinding larger stumps, chips may begin to build up under the wheels.
 - Release brake and pull machine towards you so that the "chip pile" is directly under the cutting wheel.
 - Drop cutter wheel down on "chip pile", material will be discharged from machine area.

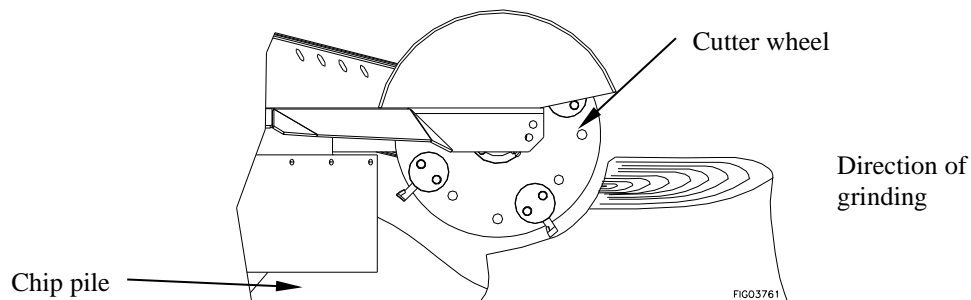

▲ WARNING: Flying Debris Hazard

Stones, chips, and debris can cause serious injury or property damage. Debris can fly 75 ft. in any direction out of the chute and bounce off objects and hit operator, bystanders or breakable objects.

- On these larger stumps, DO NOT allow grinder wheels to drop into stump hole. If a hole is in the way of your progress, fill it with chips or change position.

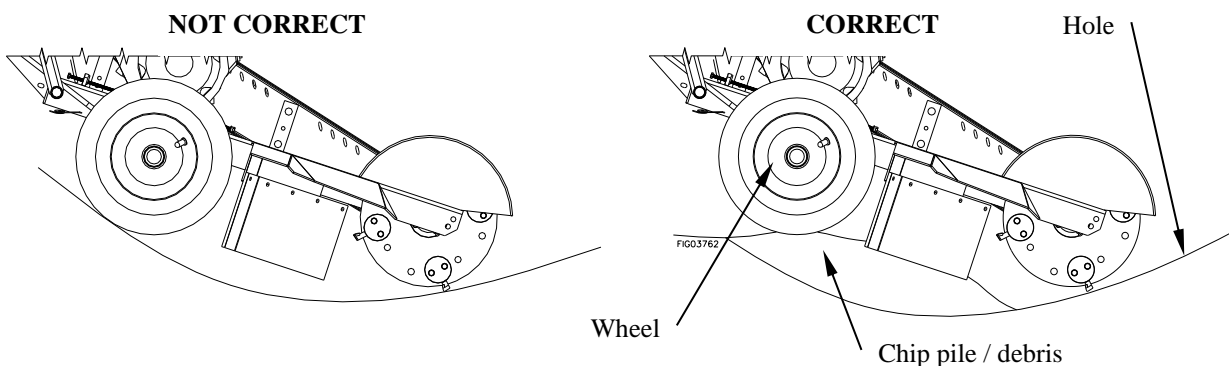

▲ WARNING:

Stop engine and set brake before leaving operator's position. **KEEP BRAKE ENGAGED** except when changing locations.

10. When finished, stop the machine.
11. Pull machine away from stump, and rake chips away from stump.

Operation (cont'd)

5. Refueling

1) Before removing gas cap, turn engine off and allow to cool for at least two minutes.

Note: A running or hot engine can ignite fuel.

2) Remove grinder gasoline cap.

3) Add gasoline through the fill opening:

- Use only an UL-approved portable gasoline container to transfer the gasoline to the grinder's tank.
- Be aware of safety warning and instructions below for avoiding static electric caused fires.

⚠ WARNING:

Static electric spark hazard

A static electric spark can explosively ignite gasoline vapor, resulting in a flash fire that could cause serious injury or death. See "Special Safety Information on Static Electricity" at end of this manual.



4) Clean up gasoline spills /splashes immediately.

- If possible, move the grinder away from spilled gasoline on the ground.
- Wipe up spilled gasoline, and wait 5 minutes for excess gasoline to evaporate before starting engine.
- Gasoline soaked rags are flammable and should be disposed of properly.
- If gasoline is spilled on your skin or clothes, change clothes and wash skin immediately.

5) Replace gasoline cap securely before starting engine.

6) Store extra gasoline in a cool, dry place in an UL-approved, tightly sealed container.

7) Filling towable units or portable containers at service stations:

Even if you have a towable unit, avoid static electric sparking while filling the gasoline tank:

- Never fill the grinder's gas tank directly from the fuel pump. The grinder's tank is not grounded and high velocity flow from the pump can cause static electricity build-up. Use an approved portable container to transfer gas to the grinder's tank.
- Use a portable container made of metal or conductive plastic. This is preferred because it dissipates static charge to ground more readily.
- Never fill a portable gas container while it is sitting inside a vehicle, trailer, trunk, or pick-up truck bed. ALWAYS place container on the ground to be filled.
- Keep nozzle in contact with container while filling. Do not use a nozzle lock-open device.

Operation (cont'd)

6. Storing the Grinder

When you are finished using the grinder and it has cooled, you must:

- Cool engine before storage.
- Clean the grinder.
- Inspect for worn or damaged parts.
- Choose covered storage location.
- Prevent accidental starting.
- Plan on exercising the engine at least monthly unless the grinder is prepared for long-term storage.

Detailed instructions are provided below.

Cool engine	Let engine cool for at least five minutes before storing. A hot engine can be a fire hazard.
Clean grinder	Clean all grease, dirt, mud and other foreign matter from the machine. Touch up paint damage to prevent rust.
Inspect grinder	Inspect the machine for worn or damaged parts and tighten any nuts or screws that may have become loose. Pay particular attention to the cutting teeth.
Choose a storage location	Store the grinder in a location that is: <ul style="list-style-type: none"> ○ Clean and dry ○ Away from sources of heat, open flames, sparks, or pilot lights, even if the grinder's gas tank is empty. Residual gasoline could ignite. ○ Away from extreme high or low temperatures. ○ Cover it for extra protection
Remove key	Remove key from starter and secure key in a safe location, or remove spark plug, in order to ensure the grinder cannot be started in a storage location or by untrained persons or children.
Start grinder every 4 weeks	The grinder should be started regularly. At least every four weeks, start the engine and let it run for 10 to 15 minutes. Monthly exercising of the grinder will dry out any moisture that has accumulated, lubricate cylinders, and clean out old gas in the carburetor. Moisture, old gas, and dry mechanical parts cause deterioration in stored engines.

Operation (cont'd)

Prepare engine for long term (seasonal) storage if needed

If you will not be able to start the grinder regularly, you must prepare the engine for long term storage to prevent gum deposits from forming and causing malfunction of the engine.

Prepare engine for long term storage by:

- **Removing all gasoline** from the tank and carburetor
- OR
- **Adding fuel stabilizer** to the gasoline (following manufacturer's instructions)

Fuel stabilizer steps:

1. Ensure gas tank is full.
2. Add fuel stabilizer to fuel tank.
3. Run engine at least 10 minutes after adding stabilizer to allow it to enter the fuel system.
4. Shut off engine
5. Disconnect spark plug wire and remove spark plug
6. Add one teaspoon oil through spark plug hole
7. Place rag over spark plug hole and turn starter (or pull the recoil) a few times to lubricate the combustion chamber.
8. Replace spark plug, but do not reconnect the spark plug wire.

⚠ WARNING: Gasoline fire/explosion hazard

Gasoline is highly flammable and explosive. Drain the fuel into an approved container OUTDOORS and far away from open flame. NEVER store an engine with fuel in the tank indoors or in poorly ventilated spaces where fuel vapor can come in contact with

- static electric sparks
- sparks from electric wiring, batteries, or running engines
- sources of heat (such as a hot engine or exhaust)
- open flames, including pilot lights

Maintenance & Repair

⚠ WARNING

ALWAYS shut off the engine, make sure the engine is cool, and disconnect the spark plug before cleaning, adjusting, or servicing the grinder. Make sure all guards and shields are replaced before using.

Maintenance	
Perform regular maintenance	Perform periodic maintenance as directed in this manual to keep the grinder in safe working condition.
Follow safety rules	<p>Read and follow these safety rules whenever you will be servicing the grinder:</p> <ul style="list-style-type: none"> • Turn off grinder. Always turn off grinder and remove spark plug or spark plug wire, and disconnect battery on electric start models before working on the engine or grinder to prevent accidental starting. • Replace guards/shields. Make sure all guards and shields are replaced after servicing the grinder. • Burns. Muffler will be hot even after unit is stopped. Allow unit to cool before servicing. • Repair. Major service, including the installation or replacement of parts, should be performed only by a qualified electrical service technician. Obtain factory approved parts from NorthStar Service at 1-800-270-0810. • Replacement parts. If a part needs replacement, only use factory approved repair parts. Replacement parts that do not meet specifications may result in a safety hazard or poor operation of the grinder and will void the warranty.
Perform engine maintenance	<p>Perform engine maintenance as specified in the engine owner's manual.</p> <p>Engine maintenance items include:</p> <ol style="list-style-type: none"> 1. Oil and oil filter changing 2. Air filter check/replacement 3. Spark plug cleaning and replacement 4. Fuel filter check/replacement 5. Fuel tank cleaning.
Inspect fuel system / check for leaks	<p>Inspect the fuel system and check for leaks on a regular basis.</p> <p>Look for: signs of leaks or deterioration, chafed or spongy fuel hose, loose connections, loose or missing fuel hose clamps, damaged gasoline tank, or defective gasoline shut-off valve.</p>
Lubricate	<p>Cutter shaft bearings and wheel bearings should be greased.</p> <p>The cutter shaft bearing is greased by pumping grease into zerks located on the housing of the bearing.</p>

Maintenance & Repair (cont'd)

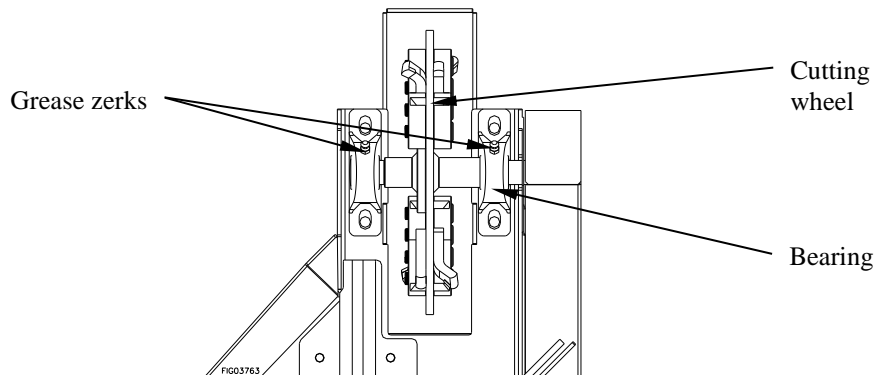

The wheels should be greased by repacking the bearings inside the wheel hub with grease.

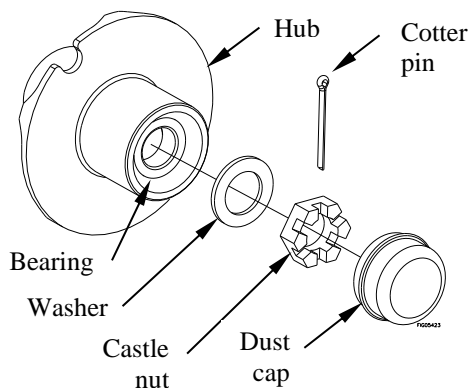

1. Remove existing cap, cotter pin, castle nut, washer, and hub off spindle.
2. Inspect inner and outer bearing and pack with grease.
3. Slide hub and washer back onto spindle.
4. Using a torque wrench, tighten the castle nut 30-40 foot-lbs.
5. Loosen the castle nut until loose enough to turn the castle nut with your fingers.
6. Re-tighten the castle nut finger tight.
7. Reinstall cotter pin and dust cap.

Grease Specification	
Soap Type	Lithium Complex
NLGI Grade	#2
Dropping Point	230°C (446°F)
Additives	Corrosion and Oxidation inhibitors, EP optional
Viscosity Index	80 Minimum

Check and adjust brake

Check that the brake is functioning properly.

- Lock the brake, push down on handle bar so that cutter wheel is off the ground.
- Push or pull the grinder- if the brake is loose, the wheel will rotate.

To adjust braking tension:

- Unscrew set screw.
- Turn knob clockwise to increase tension or counter-clockwise to decrease tension.
- Once you have set the brake to the proper tension, tighten set screw to lock adjustment knob.

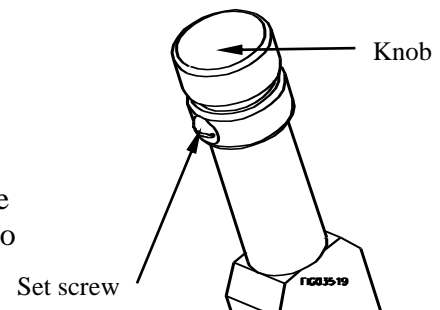

Maintenance & Repair (cont'd)

Belt Tension Adjustment

Note: Belt tension and alignment are inter-related. Do not adjust one without checking the other.

1. Remove belt guard.
2. Loosen (4) engine bolts.
3. With long socket extension drive, move engine forward with rear adjusting bolt.
4. When belt tension is proper 11 to 14 ft/lbs of tension, or 3/16" deflection, retighten all loosened bolts.
5. Reassemble belt guard.

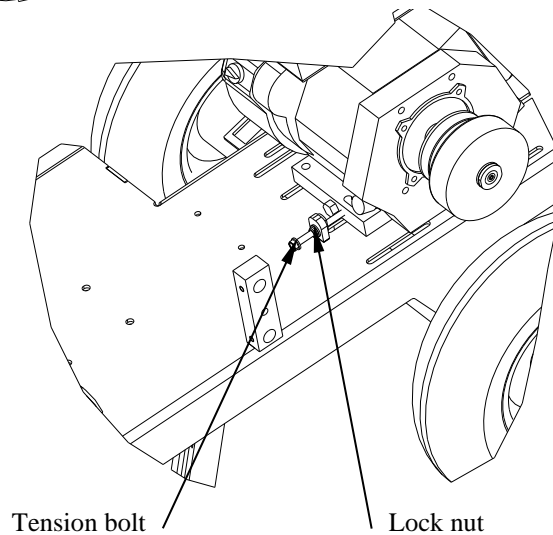
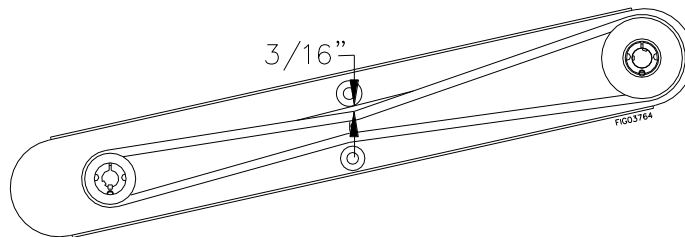
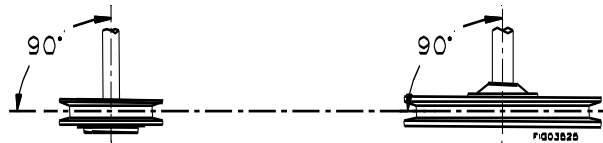

Note: New belts require a “break-in” period of approximately 10 hours. Readjustment may be necessary after “break-in.”

Note: Use only factory recommended belts. Contact your NorthStar dealer.

Maintenance & Repair (cont'd)

Stop-Switch Adjustment

⚠ CAUTION:

Never attempt to alter, modify or override this switch.

If Stop switch ever needs to be replaced or adjusted follow the below directions.

1. Loosen Hex Nut.
2. Turn the Linkage Bolt clockwise to lower or counter-clockwise to raise the point of interaction with Stop Switch. To set the proper interaction distance, grip the Operator Presence Bar & Handle Bar together and lower the Linkage Bolt onto the Switch Button until the switch button cannot be depressed any further. Then raise the linkage bolt one turn (counterclockwise).
3. Tighten Hex Nut.
4. Verify operability of stop switch before operating machine by releasing the operator presence bar next to the handle bar. You should hear a "CLICK", signifying that the Linkage Bolt has been adjusted properly.

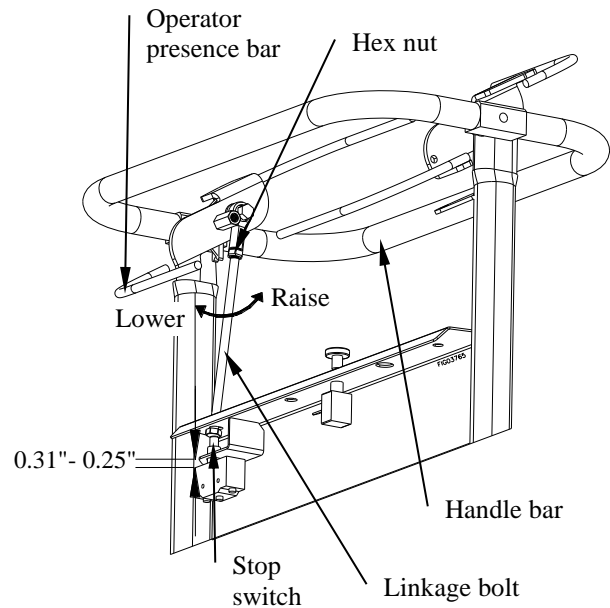

Setting & Sharpening Teeth

Among the most critical elements of the stump grinder is the cutting wheel. It is also the most subject to damage and wear. In the course of grinding stumps it not only makes contact with the wood, but also encounters numerous abrasives and objects in the stump's environment, such as dirt, stones, large rocks and buried scrap.

The loss and wear of cutting teeth can significantly impair the efficiency and performance of the stump grinder. Therefore, it is important to make frequent inspections of the condition of all the cutting teeth and to sharpen or replace any damaged or worn teeth. Sharpening the teeth before excessive wear will result in longer lasting teeth and better performance.

Sharpening Teeth

NorthStar cutting teeth are tipped with heavy-duty carbide. Carbide retains its sharpness longer; cuts faster and smoother, and can withstand heat better. Though carbide is tremendously hard, it is also reasonably brittle. Sharpen the teeth before excessive wear or if a chip is noticed. Less material will have to be removed and the teeth will last longer with more frequent sharpenings.

Maintenance & Repair (cont'd)



A properly sharpened carbide edge undergoes very little pressure in cutting. A thin, sharp edge slices its way through the material, minimizing resistance.



A rounder dull edge creates high cutting pressures because it must force its way through the material.

⚠ WARNING:

Carbide dust is harmful if inhaled. A respirator and safety glasses must be worn while sharpening.

Grinding Equipment

Existing grinding equipment plus a special grinding wheel is all that is needed to grind the teeth.

Items needed:

- Any type bench or pedestal grinder.
- Coarse grinding wheel.
- "Green wheel" for carbide grinding.

General Grinding Tips

1. Teeth can be ground freehand since precision is not important. Any variance between teeth will not be noticed and a tooth that is ground shorter in length can be adjusted when mounting.
2. If possible, set the grinder up with a coarse wheel on one side, and the "Green Wheel" on the other side.
3. Using the "Green Wheel", grind the end of the carbide until the edge is once again sharp. Avoid grinding on the top of the carbide, which would reduce its thickness and weaken it, making it more susceptible to cracking and chipping.
4. As the end of the carbide is ground away, you will have to grind a relief on the square steel shank. The steel must be ground with the regular coarse grinding wheel and not the "Green Wheel".
5. Although the angle is not critical, always grind the tooth so that there is a relief under the carbide edge.

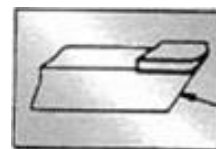

Maintenance & Repair (cont'd)

6. The tooth may be ground until the carbide until the carbide has approximately 3/16" remaining.

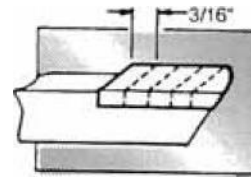

Installing Teeth

1. When installing teeth on the cutting wheel, be sure that all teeth are extended an equal length beyond the wheel. A tooth gauge (part # 793190) has been provided with the grinder for this purpose.

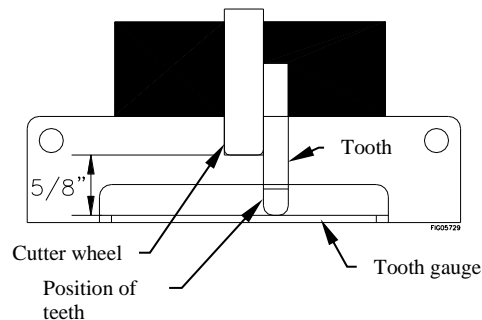

2. After teeth are located in position, lock by tightening the (2) bolts in each tooth pocket.

Tighten teeth 100 to 110 ft-lbs. torque.

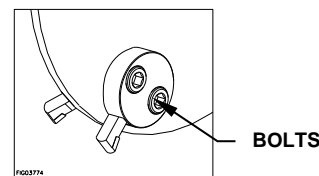

CAUTION:

Cutter wheel will be out of balance and should never be run with a tooth missing or a badly worn tooth.

Teeth should be alternated so that you have the following pattern:

SHOWN CARBIDE FACING DOWN

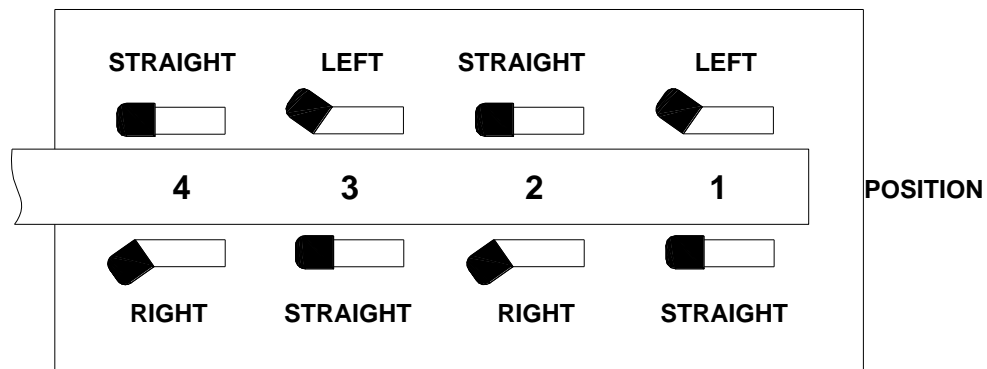

NorthStar stump grinders are equipped with reversible pockets. When reversing pockets, position them in the same exact location. This will ensure the cutter wheel will remain in balance.

Use only pockets and teeth recommended by NorthStar.

Maintenance & Repair (cont'd)

Maintenance Schedule

⚠ CAUTION:

Before attempting any maintenance, be sure that the engine is shut off, the key, the positive battery cable, and both spark plug wires are removed, and the engine is cool to the touch!

Item (What to check or action req'd)	Daily	Each Use	10 hours	20 hours	40 hours	2x/year
Bearings, Shaft - Grease				X		
Bearings, Wheel - Grease						X
Belt Tension - Tension					X	
Bolts - Tightness			X			
Engine – See manual						
Gasoline – Amount		X				
Safety Switches – Operation		X				
Warning Decals – Legible	X					
Tires, Flaps – Condition	X					
Wires, Cables – Condition		X				
Cutter Teeth - Sharpness		X				

IMPORTANT:

If a part needs replacement, only use parts that meet the manufacturer's specifications. Replacement parts that do not meet specifications may result in a safety hazard or poor operation of the grinder.

**Contact NorthStar Product Support at 1-800-270-0810
for any questions, problems, or parts orders.**

Specifications

ENGINE OPTIONS	
Make	Honda
Model	GX390UT1QAA2
CC Rating	390 cc
GENERAL	
Weight	300 lbs. (136kg)
Length	58" (147cm)
Height	51" (130cm)
Width	32" (81 cm)
RPM Operating	3600 RPM
Type of Fuel	Gasoline
Starting	Recoil
Oil Sensor	Yes
CUTTER WHEEL	
Diameter	14" (36cm)
Thickness	3/8" (.95cm)
Bearings (Dia.) (2)	1-3/16" (3cm)
Teeth Pockets	Reversible
Teeth (8)	Carbide tips
Disc RPM	3000 RPM
Drive	Direct belt drive
	Centrifugal clutch
	2 groove power band with idler bearing belt tensioners
CUTTING CAPACITY	
Above Grade	20" (51 cm)
Below Grade	16" (41 cm)
Stump Diameter	No Limit
GROUND TRAVEL	
Speed	Never exceed 45mph
Drive	Wheel Hub
	480 x 8" (480 x 20 cm)
Brake	Adjustable Brake Band
Optional tow package	296022

Summary of Important Safety Information

This section provides a summary of the various safety procedures and measures that have been presented throughout the manual. Keep this summary handy and refer to it to refresh your memory about how to safely use your grinder.

WARNING

Carefully read and make sure you understand the following safety information before using the grinder. Improper use or maintenance of the grinder can result in *serious injury or death* from *fire/explosion, carbon monoxide poisoning, lacerations, entanglement or burns*. Damage can also occur to windows, siding, vehicles, and bystanders from chips and debris which can become projectiles.

General

- **Read manual.** Read this Owner's Manual and the engine Owner's Manual completely before attempting to use and service the grinder. Serious injury or death can result if safety instructions are not followed.
- **Instruct operators.** The grinder owner or rental company must instruct all operators in safe grinder set-up and operation. Do not allow anyone to operate the grinder who has not read the Owner's Manual and been instructed on its safe use. Make sure Owner's manual is within the attached storage tube on the grinder.
- **Adults only.** Only trained adults should operate and service the grinder. Do not let children operate.
- **Under the influence.** Never operate, or let anyone else operate, the grinder while under the influence of alcohol, drugs, or medication.
- **Intended use.** Carefully read about and understand the intended use of this grinder. Do not use for other purposes, as unforeseen hazards or equipment damage may result.
- **Controls and safety labels.** Learn how to use the machine and its controls safely. Understand and follow all safety labels.
- **Weather.** Never use in foul, bad or questionable weather, which causes a slippery ground condition.

Prohibition Against Modifications

Never modify or alter the grinder in any way. Modifications can create serious safety hazards and will also void the warranty.

- **Fuel/exhaust system.** Never modify the exhaust system, fuel tanks, or fuel lines. Carbon monoxide poisoning, fire, or explosion could result.
- **Guards.** Do not operate grinder unless all guards and cover shields, which prevent access to moving parts and pinch points, are in place. Failure to guard the power transmission mechanisms *may result in serious injury or death*.

Safety – Before Use

Know how to operate

- **Review safety rules.** Before use of this grinder, review the “Rules for Safe Operation.”
- **Know how to operate.** Be thoroughly familiar with all controls and with the proper use of the equipment. Know how to stop the grinder quickly if needed.
- **Utility marking.** Call 811 for utility marking 3 days before stump grinding. Trees can grow on top of and around underground wiring that was installed many years before a tree was planted.

Getting Ready

- **Flying debris.** Clear area of objects such as stones, toys, steel wire, etc. that could become caught in moving machine parts and ejected as a projectile.
- **Operate OUTSIDE only – dangerous carbon monoxide exhaust!** Grinders give off carbon monoxide exhaust, a poisonous gas that can kill. You CANNOT smell it, see it, or taste it. ONLY run grinder OUTDOORS and at least 20 feet from the home, away from windows, vents and air intakes, to allow proper ventilation. If you start to feel sick, dizzy, or weak while using the grinder, shut off the engine and get to fresh air RIGHT AWAY. NEVER run grinder engine inside homes, garages, sheds, or other semi-enclosed spaces. These spaces can trap poisonous gases.

Summary of Important Safety Information (cont'd)

- **Cooling ventilation.** The grinder needs adequate, unobstructed flow of air to allow for proper cooling of engine and grinder head. Do not allow debris to accumulate and block airflow.
- **Transporting.** During transporting, take precautions to make sure stump grinder will not tip over and cause a fuel leak hazard.
- **Hot exhaust - fires.** Exhaust from engine can be extremely hot and cause fire. Position muffler at least 7 feet from combustible objects during operation.
- **Fire extinguisher.** Keep a fire extinguisher rated “ABC” by the National Fire Protection Association nearby is always recommended when using gasoline operated machinery. Keep it properly charged and be familiar with its use.

Personal protective equipment

- **Hearing protection.** The use of ear plugs or other hearing protection device is recommended for those in close proximity to the grinder while it is operating.
- **Eye protection.** Wear ANSI approved eye protection when operating the grinder.
- **Face protection.** A helmet with a full face visor or mesh visor with protective glasses is recommended.
- **Loose / dangling.** Loose or dangling apparel, jewelry or hair can become entangled in moving parts. Never wear jewelry or loose-fitting clothing when operating the grinder.
- **Long pants.** Wear long, heavy-duty pants to protect legs from ejected materials.

Gasoline Safety

Gasoline is highly flammable and explosive. You can be burned or seriously injured when handling fuel. Use extreme care when handling gasoline:

- **Fuel outdoors.** Fill fuel tank outdoors – never indoors. Gasoline vapors can ignite if they collect inside an enclosure. Explosion can result.
- **Use approved container.** Never pump fuel directly into engine at gas station. Static charge can build and ignite fuel. Use an UL approved fuel container to transfer gas to the engine.
- **Running / hot engine.** A running engine is hot enough to ignite fuel. Never add fuel or remove gas cap if engine is running or still hot. Stop the engine and allow to cool at least two minutes before adding fuel.
- **Heat / flames / sparks.** Keep sources of heat, flame, or sparks away while adding fuel.
- **Don't fill to the top** DO NOT overfill the gas tank. Allow at least 1" of empty space below the fill neck to allow for fuel expansion and operation on slopes.
- **Don't fill to the top.** Do not fill the gas tank to the top. Gasoline may spill when operating on a slope.
- **Replace cap.** Replace gas cap securely before starting engine.
- **Spills.** Clean up fuel spills immediately. Move grinder away from spilled fuel on the ground. Wipe fuel off engine and wait 5 minutes for excess fuel to evaporate before starting engine. Gas soaked rags should be disposed of properly.
- **On skin / clothes.** If gasoline is spilled on your skin or clothes, change clothes and wash skin immediately.
- **Inspect fuel system.** Check fuel system on a regular basis. Look for signs of leaks, deterioration, chafed or spongy fuel hose, loose or missing fuel hose clamps, damaged fuel tank, or a defective fuel shut-off valve. Do not start grinder until needed repairs have been completed.
- **Gasoline storage.** Store gasoline in a cool, dry place in an UL-approved, tightly sealed container away from children.

Safety – During Use

- **Safety equipment / controls.** Always operate the grinder with all safety covers, guards, and barriers in place and in good working order, and all controls properly adjusted for safe operation.
- **Controls.** Stay in the OPERATOR POSITION while actuating controls.
- **Know how to stop.** Know how to stop the grinder quickly if needed by releasing the operator presence bar. If this does not work, do the following in order until unit is stopped. 1. Push the stop button on the control panel. 2. Use on/off switch on engine (or ignition switch on electric start models). 3. Engage full choke by flooding the engine.
- **“Kickback”.** Machine can experience significant “kickback” when operating or first coming into contact with the stump.
- **Slipping/Falling.** Operating in wet or icy conditions could lead to losing your footing and slipping or falling.
- **Damaged.** Do not operate the grinder with damaged, missing, incorrectly adjusted, or broken parts.
- **Check for gas leak before starting.** After opening gasoline valve, smell for gas before starting engine. If you smell gas, DO NOT start engine. DO NOT light a match. DO NOT flip on an electrical switch. Exit area immediately and call fire department.

Summary of Important Safety Information (cont'd)

- **Carbon monoxide exhaust.** The running engine gives off carbon monoxide, a poisonous gas that can kill you. You CANNOT smell it, see it, or taste it. If you start to feel sick, dizzy, or weak while using the grinder, shut off the engine and get to fresh air RIGHT AWAY. See a doctor. You may have carbon monoxide poisoning.
- **Other exhaust dangers.** This product contains or emits chemicals known to the State of California to cause cancer, birth defects or other reproductive harm. Avoid inhalation of exhaust.
- **Smoking/sparks.** Never smoke near the running grinder, and never operate near sources of sparks or flames.
- **Hot muffler.** Never touch hot muffler or hot exhaust manifold. Exhaust and engine parts can be very hot and will burn you.
- **Machine's moving parts.** Keep hands, feet, and apparel away from drive belts, cutter wheel, and other moving parts. Never remove any drive belt or guard while the unit is operating. Contact with belt or rotating teeth will cause personal injury.
- **Refueling.** DO NOT refuel the engine until it has cooled at least two minutes.
- **Malfunction during operation.** Always shut the machine off if any unusual noise or vibration occurs.
- **Vibration.** Overexposure to machine vibration on a daily basis may lead to circulatory or nerve damage.
- **Adjusting / repairing.** Always turn off grinder and remove spark plug or spark plug wire before working on the grinder to prevent accidental starting.

Safety – After use

- **Cool engine before storing.** Let engine cool for at least five minutes before storing. A hot engine can be a fire hazard.
- **Shut off fuel supply.** Make sure gasoline shut-off valve is in the OFF position.
- **Prevent accidental starting.** When grinder is not in use, remove key from starter (electric start engines) and secure in a safe location, or remove spark plug in order to ensure that grinder cannot be started in a storage location or by untrained persons.
- **Storage location.** Store the grinder in a dry location away from sources of heat, open flames, sparks or pilot lights – such as water heaters, space heaters, furnaces, clothes dryers, or other gas appliances – EVEN IF the grinder's gas tank is empty. Residual gasoline could ignite.
- **Exercise regularly.** Exercise grinder every four weeks to dry out moisture that accumulates in the windings. If grinder cannot be exercised on a regular basis, prepare grinder for long term storage.

Safety - Inspection/Maintenance

Inspect and maintain your grinder on a regular basis and repair as needed to keep it in safe working condition:

- **Turn off grinder.** Always turn off grinder and remove spark plug or spark plug wire before working on the engine or grinder to prevent accidental starting.
- **Replace guards / shields.** Make sure all guards and shields are replaced after servicing the grinder.
- **Burns.** Do not touch hot muffler. Muffler will be hot even if unit is stopped. Allow unit to cool before servicing.
- **Replacement parts.** If a part needs replacement, only use parts that meet the manufacturer's specifications. Replacement parts that do not meet specifications may result in a safety hazard or poor operation of the grinder and will void the warranty.

Special Safety Information on Static Electricity

Static electricity and filling gasoline:

Static electricity can initiate from ungrounded gasoline tanks or containers, from flowing gasoline, and from persons carrying a static electric charge

Static electricity on numerous occasions has explosively ignited gasoline vapors that were present during fueling processes, resulting in serious burns to nearby persons. To avoid static electricity while fueling, certain steps must be followed before and during the fueling process in order to minimize and safely dissipate static charge build-up.

Filling Portable Containers at Service Stations:

Use a portable container to fill grinder tank. Never fill the grinder's gas tank directly from the service station's fuel dispenser pump – the grinder's tank is not grounded and the high velocity flow of gasoline from a fuel pump can cause static electric build-up. Use an approved portable container to transfer gasoline to the grinder's tank.

- **Use a portable container made of metal or conductive plastic.** It will dissipate charge to ground more readily.
- **Fill container on the ground.** Never fill the portable gas container while it is sitting inside a vehicle, trailer, trunk, or pick-up truck bed. ALWAYS place container on the ground to be filled.
- **Touch a grounded metal object before starting.** Always dissipate static charge from your body before beginning the fueling process by touching a grounded metal object at a safe distance away from fuel sources.
- **Keep nozzle in contact with container.** Keep fuel dispenser nozzle in contact with the portable container at all times while filling at a service station. Do not use the nozzle lock-open device on the dispenser hose.

About static electricity and fueling

Many common objects can accumulate and retain a static electric charge. Objects made of non-conductive materials (e.g. plastics) easily accumulate and retain static electric charge, as can objects made of conductive material (e.g. metal, water) if they are not electrically grounded. The static electric charge on an object, such as a human body or plastic fuel tank/container, can reach as high as several thousand volts!

A static electric spark can be generated if the static electric charge stored on an object “jumps” to another, less charged object. Such a spark can ignite invisible gasoline vapors that are present during fueling situations.

Typical sources of static electric hazards during fueling

The following objects can accumulate a static electric charge and cause an ignition spark in typical fueling situations:

- **Ungrounded tanks/containers.** Any ungrounded fuel tank or container can accumulate a static electric charge as a result of contact with other objects or friction during transportation. This static electricity can discharge as a spark to the grounded gasoline dispenser nozzle, as the nozzle is first brought close to the tank/container at the beginning of the fueling process.
- **Flowing gasoline.** Most people are not aware that gasoline accumulates static electric charge while flowing through a hose or pipe. This charge then transfers to and accumulates in the gas tank or container that is being filled. The total amount of charge accumulation depends on the amount of gas pumped into the container, the speed with which it is pumped, and whether or not the tank/container is grounded. If sufficient static electric charge accumulates in the fuel tank or container during the fueling process, the tank/container may discharge a spark to the grounded gasoline dispenser nozzle.
- **Persons.** A person dispensing the gasoline can carry a static electric charge on their body, typically resulting from contact with their car seat or electronics. The static electricity can discharge as a spark between that person's hand and either the grounded dispenser nozzle or the fuel tank opening.

M296020 Exploded View- Rev Q

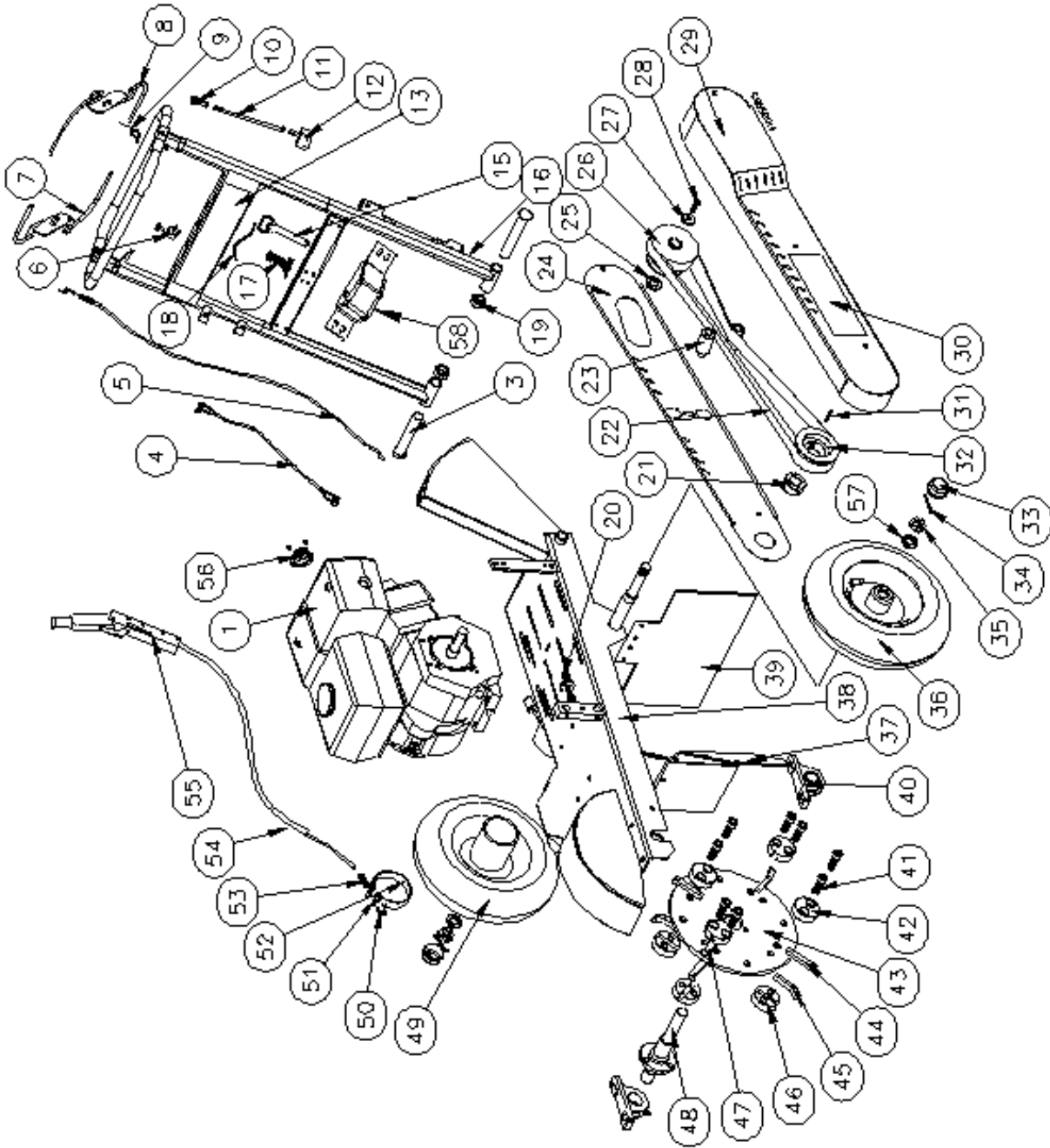

M296020 Parts List – Rev Q

Item	Part #	Description	Qty	Item	Part #	Description	Qty
1	601091	GX390 Honda engine	1	30	783544	Stump grinder decal	1
2	-	-	-	31	82143	1/4" x 1-3/4" key	1
3	37878	1" x 6" clevis pin	2	32	785368	Cutter shaft sheave	1
4	786072	Wire Harness	1	33	124A	Dust cap	2
5	791221	Throttle cable	1	34	82140	Cotter pin	2
6	786073 786074	On/off switch Black knob	1	35	777124	1" Slotted nut	2
7	785247	Throttle lever	1	36	791875	Wheel	1
8	785243	Operator presence handle	1	37	783551	Chute flap	1
9	783924	Spring	1	38	802896	Frame	1
10	782399	Ball joint rod	1	39	801705	End flap	1
11	82392	5/16"-24 x 7-1/2" linkage	1	40	783556	Pillow block bearing	2
12	783545 783769	Microswitch Microswitch bracket	1	41	82376	5/8"-18 x 1-3/4" pocket bolt	8
13	784822	NorthStar decal	1	42	784066	Counter sunk pocket	4
15	783774	4" Hitch pin	1	43	783480	Cutter wheel	1
16	797314	Handle	1	44	786475	Straight teeth	4
17	783539	2" Spring	1	45		Left hand teeth	2
18	783285	8" Lead wire, green	1	47	784067	Right hand teeth	2
19	803313	Lock collar	2	46		Threaded pocket	4
20	82304	5/16"-18 x 3" bolt	1	48	785079	Cutter shaft	1
21	783565	1-3/16" bushing	1	49	803588	Wheel & brake drum	1
22	785543	2/B71 banded belt	1	50	783570	Cable clamp	1
23	783552	Idler bearing	2	51	783568	Floating pin	2
24	785365	Inner belt guard	1	52	783567	4" Brake band	1
25	785536	Clutch spacer	1	53	783569	1.5" Spring	1
26	785542	Clutch	1	54	783295	Brake cable	1
27	785445	Shaft washer	1	55	783547	Brake lever assembly	1
28	82413	3/8"-24 x 1-3/4" HHCS	1	56	785508	Exhaust deflector w/ screws	1
29	785360	Outer belt guard	1	57	778844	Axle Washer	2
				58	794702	Lock Bracket	1

Wiring Diagram

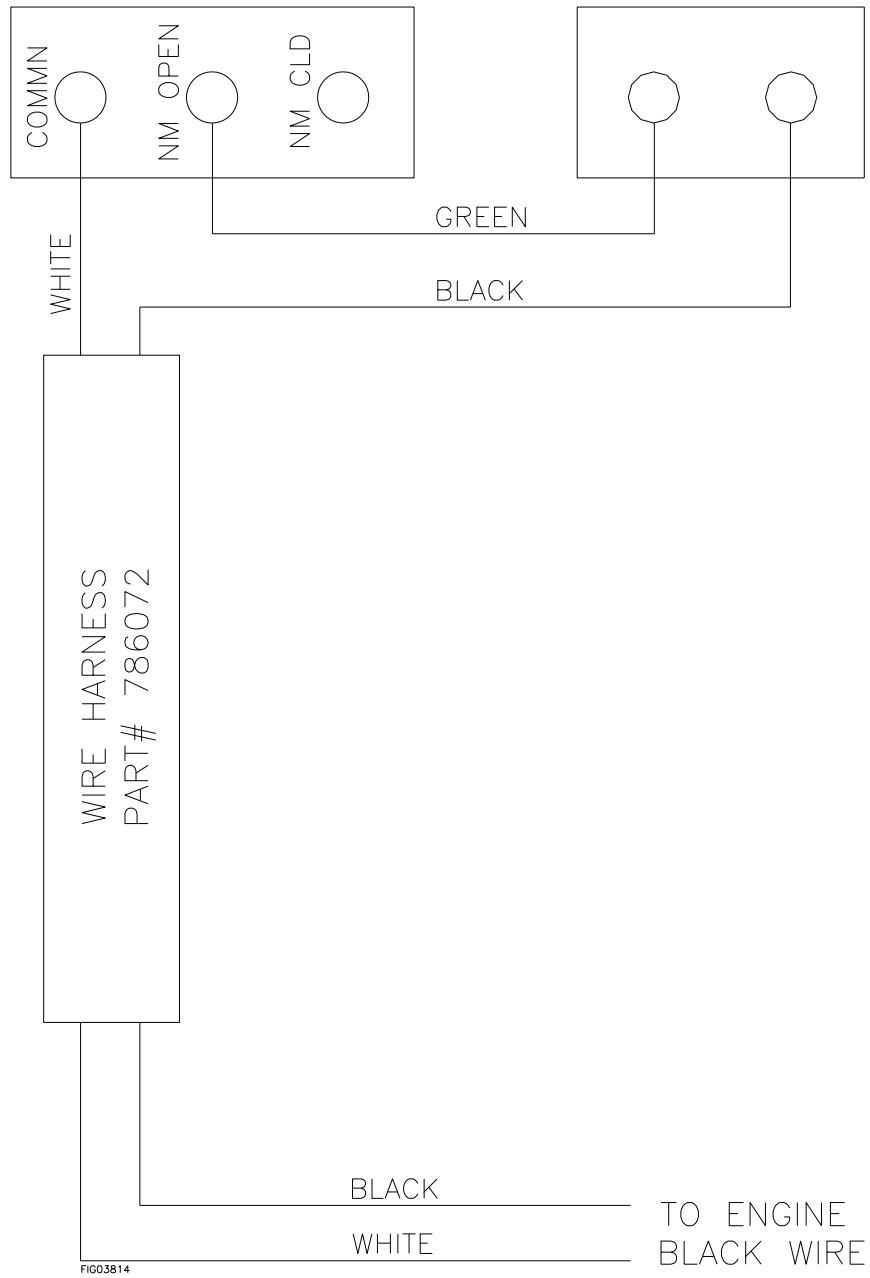

Limited Warranty Policy

Dear Valued Customer:

The NorthStar Product you just purchased is built with the finest material and craftsmanship. Use this product properly and enjoy the benefits from its high performance. By purchasing a NorthStar product, you show a desire for quality and durability.

Like all mechanical equipment this unit requires a due amount of care. Treat this unit like the high quality piece of machinery it is. Neglect and improper handling may impair its performance. Please thoroughly read the instructions and understand the operation before using your product.

Limited Warranty

NorthStar shall warranty any piece of equipment manufactured, or parts of equipment manufactured, to be free from defects in material or workmanship for a period of 2 years from the date of purchase by user. This warranty applies to the original purchaser of the equipment and is non-transferable. Verification of purchase is the responsibility of the buyer. Parts will be replaced or repaired at no charge, except when the equipment has failed due to lack of proper maintenance. Any misuse, abuse, alteration or improper installation or operations will void warranty. Determining whether a part is to be replaced or repaired is the sole decision of NorthStar.

NOTE: Some services performed by parties other than NorthStar may void warranty.

This warranty covers parts only. It will not provide for replacement of complete products due to defective parts. Components not manufactured by NorthStar such as engines are guaranteed by their manufacturer and can be serviced at factory-authorized locations near you. Any costs incurred due to replacement or repair of items outside of a NorthStar approved facility is the responsibility of the buyer and not covered under warranty. NorthStar can supply you with the service center location in your area.

This warranty specifically excludes the following; failure of parts due to damage caused by accident, fire, flood, windstorm, acts of God, applications not approved by NorthStar in writing, corrosion caused by chemicals, use of replacement parts which do not conform to manufacturer's specifications, and damage caused by vandalism. Additional exclusions: loss of running time, inconvenience, loss of income, or loss of use, including any implied warranty of merchantability of fitness for a specific use.

Warranty does not cover items subject to normal wear such as tires, receptacles or any part subject to direct physical contact by the public. This warranty does not cover any personal injury or damage to surrounding property caused by failure of any part.

This warranty is in lieu of any other warranty expressed or implied and NorthStar assumes no other responsibility or liability outside that expressed within this warranty.

Please fill in the following information and have it on hand when you call in a warranty claim.

Customer Number: _____

Date of Purchase: _____

NorthStar Serial Number: _____

Item Number: _____

⚠ WARNING: This product can expose you to chemicals including gasoline engine exhaust, which is known to the State of California to cause cancer, and carbon monoxide, which is known to the State of California to cause birth defects or other reproductive harm.

For more information go to www.P65Warnings.ca.gov.



Manufactured by
Northern Tool + Equipment Co., Inc.
Burnsville, MN 55306
NorthernTool.com
Made in the USA