

# TOPAZ®

Portable Air Conditioners

## Owner's Manual

Models: TZ-12AB - TZ-60AB4

1-800-836-7432

### Warning!

Improper installation, adjustment, alteration, service, or maintenance can cause injury or property damage. Please read instructions before installing, operating or servicing the *TOPAZ* unit.

### Avertissement !

Le fait de modifier ou de mal installer, régler, réparer ou entretenir cet appareil peut entraîner des blessures ou des dommages matériels. On doit lire attentivement les directives d'installation, d'utilisation et d'entretien avant de manipuler l'unité TOPAZ

This manual is the property of the owner. Leave with the unit when set-up and start-up are complete. TEMP-AIR Inc. reserves the right to change design and specifications without prior notice.

Unit Specifications .....	3
Rating Information .....	3
Inspection .....	4
General Description .....	4
General Requirements .....	4
Standard Features .....	4
Optional Features .....	5
Installation Instructions .....	6
Unit Operation .....	6
Preventative Maintenance .....	7
Troubleshooting Guide .....	8
Installing Replacement Parts .....	10
Accessories .....	11
Replacement-Parts List .....	12
Wiring Schematic, TZ-12AB, TZ-24AB and TZ-36AB .....	14
Wiring Schematic, TZ-18AB .....	15
Wiring Schematic, TZ-60AB .....	16
Wiring Schematic, TZ-60AB4 .....	17

**Are you equipped to  
handle the heat?**

## Unit Specifications

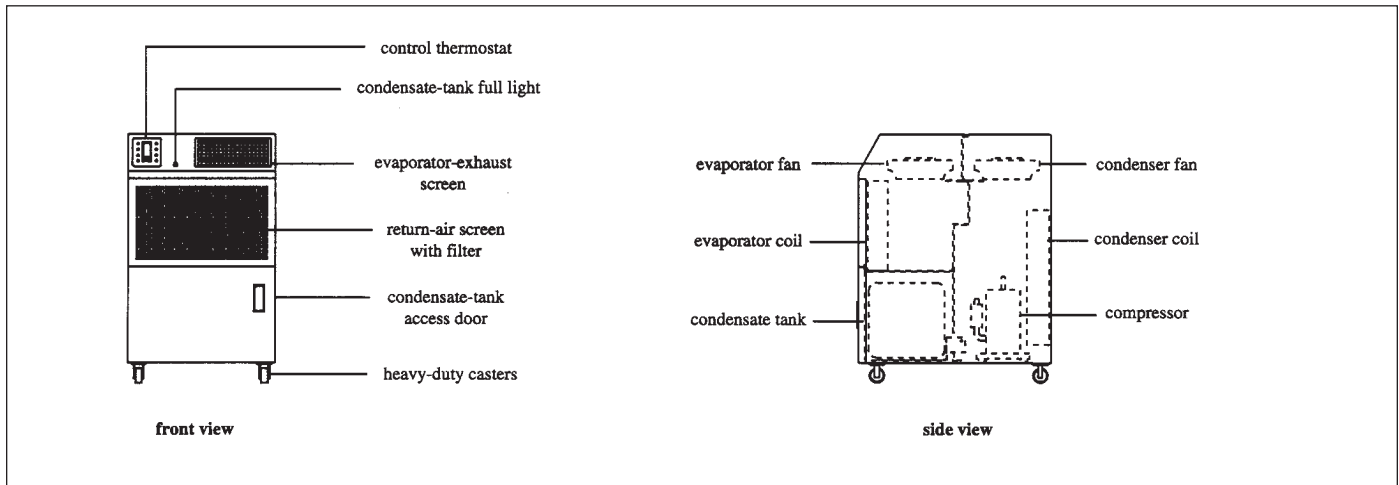

## Rating Information

SPECIFICATIONS	TZ-12AB	TZ-18AB	TZ-24AB	TZ-36AB	TZ-60AB	TZ-60AB4
<b>Cooling Capacity, BTU/hr<sup>1</sup></b>	11,900	17,200	28,300	41,000	76,500	77,500
<b>Power Supply<sup>2</sup> Volts/Ph/Hz/Amps</b>	115/1/60/15	115/1/60/15	208-230/1/60/20	208-230/1/60/30	208-230/1/60/60	460/3/60/20
<b>Thermostat Control</b>	Mechanical	Mechanical	Mechanical <sup>3</sup>	Mechanical <sup>3</sup>	Mechanical <sup>3</sup>	Mechanical <sup>3</sup>
<b>Metering Device</b>	TX Valve	TX Valve	TX Valve	TX Valve	TX Valve	TX Valve
<b>Total Power Consumption, kW</b>	1.4	1.4	3.0	4.5	8.9	11.1
<b>Current Consumption, amps</b>	11.9	12	13.2	19.7	38.7	14.0
<b>Recommended Circuit Amps</b>	15.0	15.0	20.0	30.0	60.0	20.0
<b>NEMA Plug Type</b>	5-15P	5-15P	6-20P	6-30P	wired	wired
<b>CER Rating</b>	10.4	12.8	10.3	10.0	8.9	8.3
<b>Evaporator CFM, free discharge</b>	350	600	750	1,200	2,300	2,300
<b>Condenser CFM</b>	500	1,000	1,000	1,500	3,900	3,900
<b>Maximum ESP, in wc</b>	0.10	0.10	0.10	0.10	0.50	0.50
<b>Maximum Duct Length, ft</b>	40	40	40	40	40	40
<b>Condensate-Pump Head, ft</b>	15	15	15	15	15	15
<b>Operating Limits, (min-max) °F</b>	65-105	65-110	65-105	65-105	65-110	65-110
<b>Sound Level, dB</b>	57	63	63	67	71	71
<b>R-410A Charge, oz</b>	28	46	56	70	97	97
<b>L x W x H, in</b>	26 x 20 x 34	29 x 28 x 41	29 x 28 x 41	30 x 28 x 51	42 x 30 x 70	42 x 30 x 70
<b>Weight, net wt/shipping wt, lb</b>	163/205	232/286	251/305	336/395	650/685	650/685

1. Rating conditions: 90° F at 60% RH

2. Electrical ratings based on UL 484

3. Electronic/Programmable Thermostat available

## Inspection

1. Inspect unit on delivery.
2. Report any damage to the delivery carrier.
3. Request a written inspection report from the Claims Inspector to substantiate claim.
4. File claims with the delivery carrier.
5. Compare unit received with description of product ordered.

## General Description

Topaz Portable Air Conditioners are designed to spot cool industrial, commercial, institutional, and construction sites. Six models provide 11,900 to 77,500 BTU/hr. Options include discharge nozzles to direct conditioned air precisely where needed, and flexible duct to transfer condenser hot air either outside or to an adjacent area.

Topaz Portable Air Conditioners are completely self-contained and housed within an insulated cabinet. The unit's exterior is constructed of galvanized steel and protected with a tough powder-coated, polyester finish. All models are equipped standard heavy-duty casters for portability.

## General Requirements

Topaz Portable Air Conditioners are designed for ease of operation and rugged dependability. Follow installation and maintenance instructions completely. Fill out and return the warranty registration card within 30 days of purchase to register the warranty.

## Standard Features

### Serviceability

Topaz Portable Air Conditioners have removable side panels for easier servicing from all sides.

The interior of the unit is divided into four sub-compartments. The upper right encloses the evaporator coil and fan, and provides access to the thermostat and fan switch. The lower right contains the condensate tank and access to the high-pressure switch.

The condenser fan on air-cooled models can be found in the upper left compartment. The lower left compartment

encases the condenser coil, compressor, and most electrical components.

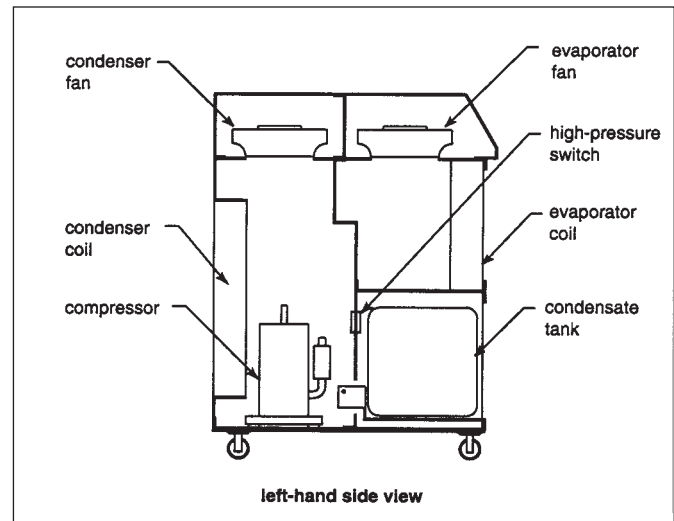

### High-Pressure Safety Switch

All models feature a manual reset, high-pressure switch. If refrigeration circuit pressure exceeds control limits, power shuts off to protect the compressor and other critical components.

**Note:** Wait four minutes to restart unit after high-pressure safety switch trips.

### Freeze Protection Control

The TZ-12AB, 24AB, 36AB, 60AB and 60AB4 models are equipped with an automatic freeze protection control. This control turns the compressor off if moisture on the evaporator coil freezes and blocks the coil. Normal cooling operation resumes when the temperature of the coil rises and the ice melts.

### Short Cycle Protection Timer

The TZ-12AB, 24AB, 36AB, 60AB and 60AB4 models are equipped with a short cycle protection timer. The timer provides a five-minute delay before the refrigerant compressor restarts. Under normal conditions, no adjustments are necessary.

## Manual Temperature-Control System

The manual temperature control system allows you to set the desired temperature by simply rotating the WARMER/COOLER dial either left or right. The supply air fan can be set to run continuously whether the cooling circuit cycle is on and off, or can be set to cycle on and off with the cooling circuit.

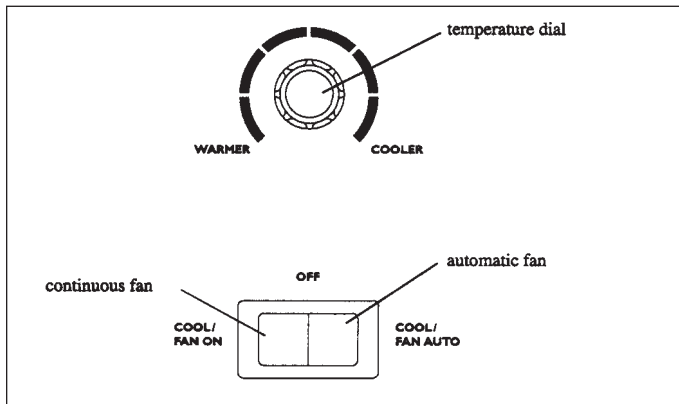

## Filter

All units are equipped with removable, washable, aluminum-mesh air filters. Located behind the return-air and discharge-air grilles, these can be removed and easily cleaned.

## Condensate Tank

A five-gallon, polyethylene tank in the lower-front compartment of the unit collects evaporator-coil condensate moisture. When full, the weight of the tank activates a cutout switch, turning the refrigeration circuit OFF and illuminating the condensate tank-full light on the unit's front. The tank is readily accessible behind a hinged door. Simply remove, drain, replace, and restart.

**Note:** The unit will not operate unless the tank is drained periodically. An optional condensate pump is available for continuous operation.

## Optional Features

### Condenser Duct

Condenser discharge air can be removed from the conditioned space with flexible duct. Use 40-ft maximum for all models. Allow six feet for every 90° bend. Do not exceed 0.10-in wc external static pressure at the condenser.

### Ceiling-Panel Duct Kit

A ceiling-panel duct kit comes complete with flexible duct and a 2-ft by 2-ft ceiling-tile adapter which allows condenser air to be vented to the plenum area above a suspended ceiling.

### Discharge Nozzle Kit

A dual-nozzle, discharge-air assembly optimizes the ability to direct cool air precisely where needed. The flexible nozzles are attached to a mounting plate that fits over the evaporator-air grille. See Accessory Information on page 11 for proper sizing.

### Condensate Pump

A condensate pump automatically drains the condensate pan by removing evaporator-coil water allowing continuous operation. The pump is connected to the condensate drain and to the air conditioner's power supply. A hose runs from the unit to a convenient drain or outdoor location.



### Cord Kit (LCDI) (TZ-12AB, 18AB, 24AB, 36AB)

The LCDI cord set provides both personal shock as well as cord arcing and fire protection. Use the LCDI cord kit provided by TEMP-AIR Inc.

## Installation Instructions

### Before Installing

Check unit for damage. Air conditioners are inspected at the factory. If any damage has occurred, save the packaging and file a claim with the delivering carrier within fifteen working days. *TOPAZ* requires minimal installation. Plug unit in proper NEMA receptacle, and it begins to cool immediately.

Model	Plug Configuration		
TZ-12AB TZ-18AB 115V		15A/115V NEMA 5-15P	NEMA 5-15R
TZ-24AB 208-230V		20A/230V NEMA 6-20P	NEMA 6-20P
TZ-36AB 208-230V		30A/230V NEMA 6-30P	NEMA 6-30P

### Electrical Supply

Determine the proper power by checking unit's rating plate. Refer to the Specifications section on page 3 for voltage and fuse requirements. Use wall outlets and receptacles found in the table below.

Operating unit on improper voltages voids the warranty.

**Note:** Extension cords may be used if rated at a minimum 120-V, 20-amp for models TZ-12AB and TZ-18AB or 230-V, 20-amp for model TZ-24AB, or 230-V, 30-amp for model TZ-36AB. Extension cords can not be used with the TZ-60AB or TZ-60A4B. Extension cords must be fitted with the appropriate grounding-type attachment plug. Use 25-ft maximum length extension.

### TZ-60AB4 — 3 Phase Wiring Instructions

The rotation of a three-phase AC motor/compressor depends on the phase sequence of the incoming power supply. Reversing any two of the three power supply leads will reverse the rotation of the motor/compressor. Improper rotation of the motor/compressor can lead to damage of the equipment.

## Unit Operation

### Fan

1. Place unit on level surface.
2. Plug unit in.
3. Press the COOL/FAN on switch for continuous fan operation. The cooling circuit will cycle on and off. Press the COOL/FAN AUTO switch for cycling the fan operating on and off with the cooling circuit.

### Cooling Cycle

1. Set the desired temperature by adjusting the WARMER-COOLER dial from 68°-115°

**Note:** Wait 4 minutes between turning cooling mode off and on.

### Preventative Maintenance

*TOPAZ* provides maximum performance and reliability with minimum maintenance. The refrigeration and electrical circuits of the system should be serviced by qualified technicians only. To prolong the life of the unit, perform regular maintenance as described below.

### Blower Motors

The blower motor has permanently lubricated ball bearings and require no relubrication. Inspect fan for buildup of dirt on blades. Clean as needed.

### Filters

A clogged filter causes the unit to operate at reduced efficiencies. Inspect filter every six weeks, or more, if operating in a dirty environment. The evaporator's washable-aluminum filter is located behind the return-air grille, and can be easily removed by pulling out the grille, opening the return-air grille and slowly lift towards hinge.

The condenser's washable aluminum filter is located in the lower back of the unit. Remove by releasing the retaining clip and pull out. Wash filters periodically by placing them in a dishwasher, or soak in a solution of warm water and detergent for ten minutes. Rinse clean with hot water, shaking excess moisture from filter to dry.

### Coil Cleaning

Evaporator and condenser coils can be cleaned using compressed air.

## **Condensate Pump**

1. Disconnect unit from power source before attempting to service or remove any component.
2. Be sure floats move freely. Clean as necessary.
3. Remove floats and check for obstructions. Clean as needed.
4. Clean tank with warm water and mild soap when mineral deposits are visible.
5. Check inlet and outlet piping. Clean as necessary. Be sure there are no kinks in the lines that can inhibit flow.
6. Exterior of the unit can be cleaned with a damp cloth. Do not allow water to enter condenser fan outlet or the thermostat.

## **Belt Tension, (models TZ-60AB and TZ-60AB4 only)**

Topaz models TZ-60AB and TZ-60AB4 are equipped with adjustable sheaves on the evaporator and condenser fans. Conditioned-air and condenser-air are controlled using double-inlet, forward-curved fans driven by belt and sheave combinations.

Adjust belt tension for 3/16-in deflection, with 2 lbs force.

## **Sheave Adjustment**

The evaporator-fan and condenser-fan sheaves are factory pre-set and should not be adjusted. Periodically check that sheaves are securely fastened to blower shafts by tightening the set screw on the stationary half of sheave.

If necessary, adjust pitch by loosening the set screw on the adjustable half of the sheave. Turn sheave clockwise until it touches the stationary half.

### **To adjust evaporator motor sheave:**

Turn sheave counterclockwise 3 1/2-turns and tighten set screw.

### **To adjust condenser motor sheave:**

Turn sheave counterclockwise 4-turns and tighten set screw.

## Troubleshooting Guide

Service, other than routine maintenance, should be performed by a qualified electrical and refrigeration professional.

Problem	Cause	Remedy
Unit does not run	Power interruption	Check external power supply. Look for blown fuses or tripped circuit breakers. Reset or replace.
	Thermostat inoperable	Setting may be too high. Check and reset. Thermostat may be out of calibration or defective. Replace.
	Electrical Panel -24-Volt transformer defective (TZ-12AB, 18AB, 24AB, 36AB and 60AB only) -Contactor coil defective -Contacts stuck open, burned or dirty -Wires loose	Check output of transformer. If not supplying 24 volts, replace.  Replace. Correct or change. Tighten connections.
Evaporator fan runs, but compressor and condenser fan does not start	Low voltage	Check power supply for voltage outside the range of 106 to 126-V on 115-V units and 187 to 253-V 208/230- V units.
	Thermostat	Examine control unit for loose wires and tighten. Wait four minutes before re-starting.
	High-pressure control switch turning unit off	Clean condenser coil filter. Clean condenser discharge screen. Check for defective condenser fan motor. Replace if necessary. Restricted duct.
	Short cycle timer not timed out (TZ-12A, 18AB, 24AB, 36AB, and 60AB only)	Wait 5 min for timer to allow compressor to restart.
	Compressor contactor open or burned	Replace.
	Refrigerant leak - no freon	Locate leak and repair. Evacuate unit and recharge.
	Loose or defective wires,	Check for loose or shorted conductors. Secure contact between wires and connectors. Repair or replace as necessary.
	Defective compressor	Check for shorts, opens, and grounds. Compressor replacement should be done by a service technician.
	Condensate tank-full	Empty tank and replace. (See pg. 5 - condensate tank)
	Red indicator light defective	Check tank, if full, remove tank, empty and replace. If unit comes back on replace defective light. (See pg. 10)
Compressor runs, but fan does not run	Shorted or open run capacitor(s)	Replace.
	Condensate jumper plug or condensate pump not installed	Unit must have either condensate pump or condensate jump plug installed to operate unit.
	Open fan motor coil circuit	Replace fan motor.
	Shorted or open fan-motor capacitor	Replace capacitor.
	Loose or defective wires	Trace and repair.
	Overload relay tripped (TZ-60AB only)	Open rear access cover, push in red manual reset button on overload relay, wait 5 min for compressor to restart.

Problem	Cause	Remedy
Insufficient cooling	Insufficient airflow through evaporator coil due to: -Dirty air filter in unit -Dirty evaporator coil -Ice on evaporator coil -Obstructed air intake -Low refrigerant -Improper Motor Rotation (TZ-60AB4 only)	See Preventive Maintenance section of this manual.  -Clean filter. -Clean filter with a vacuum cleaner and hose. -Defrost. Run on fan only. -Remove obstruction. -Repair leak in system. Reverse two of the three power supply leads (See TZ-60AB4. Phase wiring instructions pg. 6)
	Unit improperly sized	Check to assure unit is sized for load. Add supplemental unit if required.
Noisy operation	Copper tubing vibrating	Adjust by bending slightly to firm position. Segregate tubes touching cabinet or each other.
	Loose cabinet or internal component Machine vibrating - out of level Blower motor bearing defective	Check and tighten loose screws. Level unit base. Replace blower motor.
Water leaks from pan	Leaky drain pan	Replace pan.
	Drain plugged	Check and clear obstruction.
	Loose evaporator, drain, or condensate pump hose	Tighten connections.
	Defective condensate pump or excessive lift on pump	If elevation exceeds 20-ft, a larger pump is required. Pump does not operate properly if combination of lift height and length of drain line exceeds 20-ft. Change pump, if defective.
Evaporator coil freezing and shuts unit down	Unit not on level surface.	Level.
	Evaporator exhaust screen obstructed	Remove obstruction.
	Freeze protection control not operating correctly (TZ-12AB, 24AB, 36AB, 60AB and 60AB4 only)	Check that control is securely attached to evaporator coil's outlet and that insulation is in place. Check wiring connections to freeze protection control.
Unit not delivering proper air flow TZ-60AB4 only	Drive belt damaged or not adjusted correctly	Check condition and adjustment of evaporator and condenser fan belts and sheaves. Adjust belts for 3/16-in deflection. (See pg. 7)

## Installing Replacement Parts

### Ceiling-Panel Duct Kit

1. Secure one end of the duct to the ceiling-panel adapter and the other end over the unit's duct collar.
2. Place the ceiling-panel adapter under suspended ceiling panel's framework directly above unit.

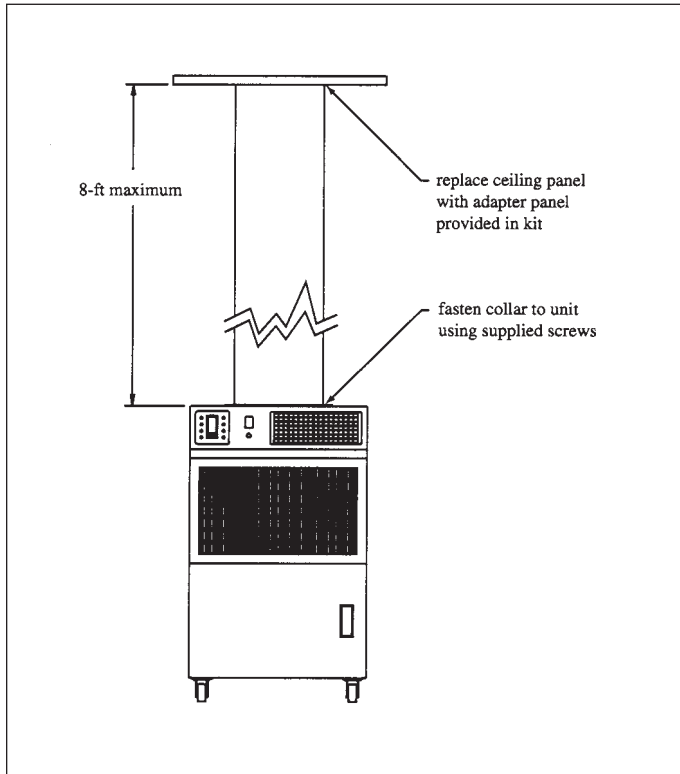

### Condensate Pump

1. Unplug unit from power source. Remove condensate tank and hose from drain pan.
2. Place condensate pump on condensate-tank shelf. Align holes in shelf with mounting slots in molded tank. Secure pump to condensate-tank shelf using two supplied sheet metal screws.
3. Remove electrical plug and jumper wire from receptacle located on bulkhead next to the service fittings.
4. Connect condensate pump's power plug to receptacle.
5. Install hose from drain pan to the pump inlet.
6. Remove plug from hole in side of unit.

7. Install drain hose from condensate-pump outlet through hole in side of unit to a convenient drain or outdoor location.

### Fan Motors (TZ-12AB through TZ-36AB)

1. Remove cabinet's side panels.
2. Disconnect evaporator-motor wires at the connector plug.
3. Disconnect condenser-motor wires at the connector plug.
4. Remove unit's top and disconnect thermostat at connector plug.
5. Remove screws securing blower mounts. All screws are external and visible.
6. Remove motors and blower and assemblies.
7. Remove blower and fan assembly.
8. Install new motors, reversing the removal procedure.

### Fan Motors (TZ-60AB and TZ-60AB4)

1. Disconnect power from unit
2. Remove cabinet's side panels.
3. Disconnect wires from motor that needs to be replaced.
4. Disconnect belt from drives.
5. Remove bolts holding motor onto motor mount.
6. Remove sheave from motor.
7. Install new motor, reversing the removal procedure.
8. Adjust sheave and belt tension as outlined in preventative maintenance.

### Red Indicator Light

1. To replace pilot light, disconnect wires from control panel, bend tinnerman clip holding light, and pull out.
2. Install new light, reversing the procedure.

## Accessories

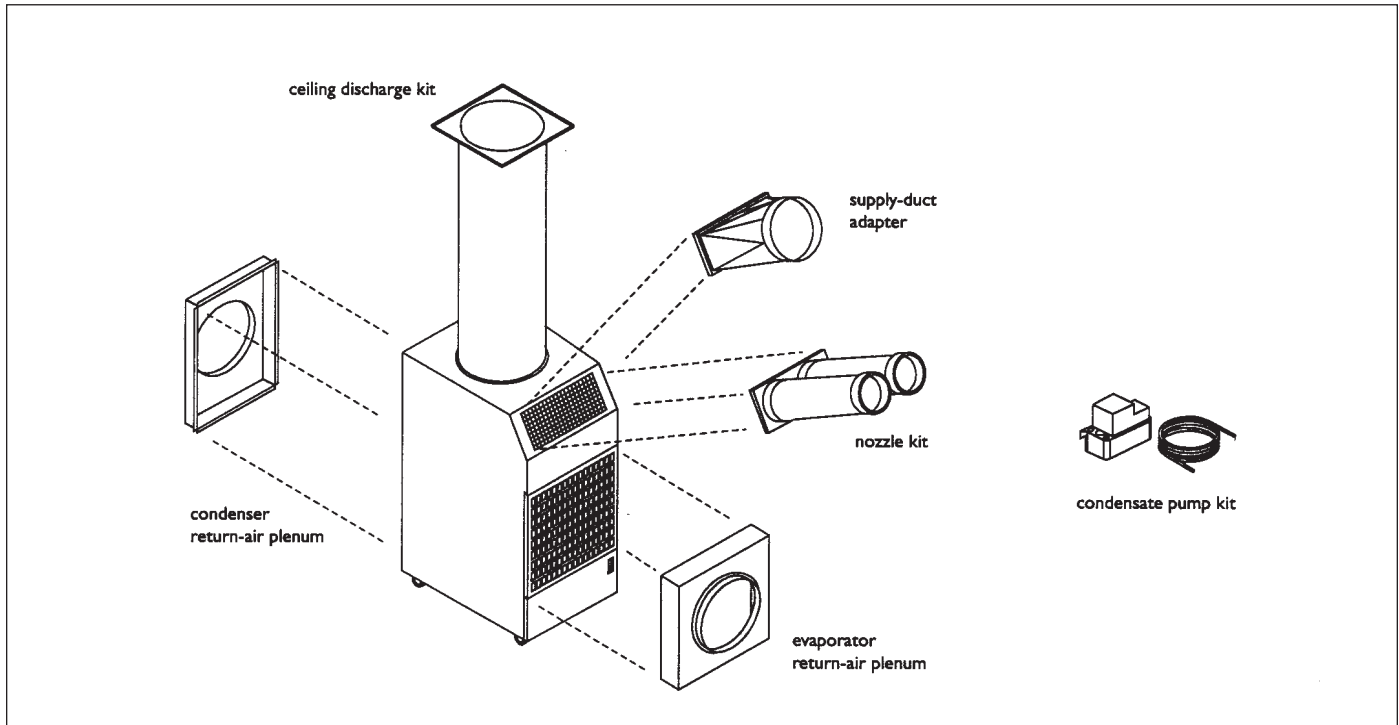

Part	Description
NK-1	two, 4-in nozzles with attachment kit, TZ-12AB
NK-2	two, 6-in nozzles with attachment kit, TZ-18AB, TZ-24AB and TZ-36AB
NK-3	two, 8-in nozzles with attachment kit, TZ-60AB and TZ-60AB4
CK-1	10-in ceiling discharge kit, TZ-12AB
CK-3	14-in ceiling discharge kit, TZ-18AB, TZ-24AB and TZ-36AB
CK-4	20-in ceiling discharge kit, TZ-60AB and TZ-60AB4
PC-1	condensate pump, 115 volt, TZ-12AB and TZ-18AB
PC-2	condensate pump, 208/230 volt, TZ-24AB, TZ-36AB and TZ-60AB, TZ-60AB4
PT-1	programmable thermostat, TZ-12AB, TZ-24AB, TZ-36AB, TZ-60AB and TZ-60AB4
CP-1	10-in condenser return-air plenum, TZ-12AB
CP-2	14-in condenser return-air plenum, TZ-18AB and TZ-24AB
CP-3	14-in condenser return-air plenum, TZ-36AB
CP-4	20-in condenser return-air plenum, TZ-60AB and TZ-60AB4
CS-1	condenser screen, TZ-12AB
CS-2	condenser screen, TZ-18AB and TZ-24AB
CS-3	condenser screen, TZ-36AB
CS-4	condenser screen, TZ-60AB and TZ-60AB4
EP-1	10-in evaporator return-air plenum, TZ-12AB
EP-2	14-in evaporator return-air plenum, TZ-18AB and TZ-24AB
EP-3	14-in evaporator return-air plenum, TZ-36AB
EP-4	20-in evaporator return-air plenum, TZ-60AB and TZ-60AB4
DA-6	6-in cold-air supply duct adapter, TZ-12AB
DA-10	10-in cold-air supply duct adapter, TZ-18AB, TZ-24AB and TZ-36AB
DA-14	14-in cold-air supply duct adapter, TZ-60AB and TZ-60AB4
CD-60	14-60P plug kit with 6' cord

## Replacement parts List

Description	Part Number	TZ-12AB	TZ-18AB	TZ-24AB	TZ-36AB	TZ-60AB	TZ-60AB4
service valve, 5/16-in	88400.284		•	•			
service valve, 3/8-in	88400.249	•					
service valve, 1/2-in	88400.250	•	•	•	•	•	•
service valve, 5/8-in	88400.251						
service valve, 3/4-in	88400.252				•		
service valve, 7/8-in	88400.256					•	•
filter drier	83201.043	•	•	•			
	83201.044				•		
	83200.169					•	•
expansion valve	88400.477	•					
	88400.478		•				
	88400.479			•	•		
	88400.480					•	•
evaporator blower & motor assembly	83100.102	•					
	83100.159		•				
	83100.117			•			
	83100.118				•		
evaporator blower	80500.138					•	•
evaporator motor	85600.1.21					•	
condenser blower & motor assembly	85600.101						•
	83100.116	•					
	85400.160		•				
	83100.118			•			
	83100.119				•		
condenser blower	80500.137					•	•
condenser motor	85600.2.17					•	
	85600.101						•
compressor	82200.023	•					
	82200.028		•				
	82200.061			•			
	82200.060				•		
	82200.065					•	
	82200.066						•
evaporator-motor capacitor	85601.713	•			•		
	85601.724		•				
	85601.714		•				
	85601.723			•			
	85601.727					•	
condenser-motor capacitor	85601.724	•					
	85601.021		•		•(2)		
	85601.713			•			
compressor-motor capacitor	85601.716	•		•			
	85601.722		•		•		
	83100.211					•	
supply cordset	82900.254	•	•				
	82900.255			•			
	82900.257				•		
control transformer	88000.043	•		•	•		
	88000.044					•	•(2)
	88000.014						•
fan contactor	87300.242	•	•	•	•	•(2)	
compressor contactor	87300.258					•	
	86300.050		•				
red indicator light	80700.112		•				
	80700.051	•		•	•	•	•
filter door latch	84900.044	•	•	•	•		

Description	Part Number	TZ-12AB	TZ-18AB	TZ-24AB	TZ-36AB	TZ-60AB	TZ-60AB4
door handle	83800.004					•	•
condensate-pan switch	87500.128	•	•	•	•	•	•
evaporator filter	83200.171	•					
	83200.172		•	•			
	83200.173				•		
	83200.174					•	•
condenser filter	83200.160	•					
	83200.161		•	•			
	83200.162				•		
	83200.175					•	•
evaporator coil	81400.301	•					
	81400.303		•	•			
	81400.305				•		
	81400.298					•	•
condenser coil	81400.302	•					
	81400.304		•	•			
	81400.306				•		
	81400.299					•	•
2-in caster, (2) per unit	81000.031	•					
2-in swivel caster, (2) per unit	81000.039	•					
3-in caster, (2) per unit	81000.040		•	•	•		
3-in swivel caster, (2) per unit	81000.035		•	•	•		
3 1/4-in caster, (2) per unit	81000.041					•	•
3 1/4-in swivel caster, (2) per unit	81000.042					•	•
high pressure switch	87500.424	•	•	•	•	•	•
manual thermostat	87800.102	•	•	•	•	•	•
condensate tank	99900.299	•	•	•	•	•	•
condensate pan adjusting spring	88600.104	•	•	•	•	•	•
lower spring	88600.107	•	•	•	•	•	•
remote indoor sensor	86700.024	•	•	•	•	•	•
spring clip, 3/8-in	81300.030	•	•	•	•	•	•
door - snap-in switch	84900.054	•	•	•	•	•	•
freeze protection control	87800.090	•					
	87800.091			•	•		
	87800.092					•	•
remote thermostat probe	87800.087	•		•	•	•	•
drain pan	99900.302	•					
	99900.303		•	•	•	•	•
evaporator motor sheave	86900.033					•	•
evaporator blower sheave	86900.553					•	•
condenser motor sheave	86900.029					•	•
condenser blower sheave	86900.544					•	•
condensate jumper plug	88800.165	•	•	•	•	•	•
3-amp fuse	83500.035						•(4)
20-amp 3 pole contactor	87300.416						•(2)

# Wiring Schematic, TZ-12AB, TZ-24AB and TZ-36AB

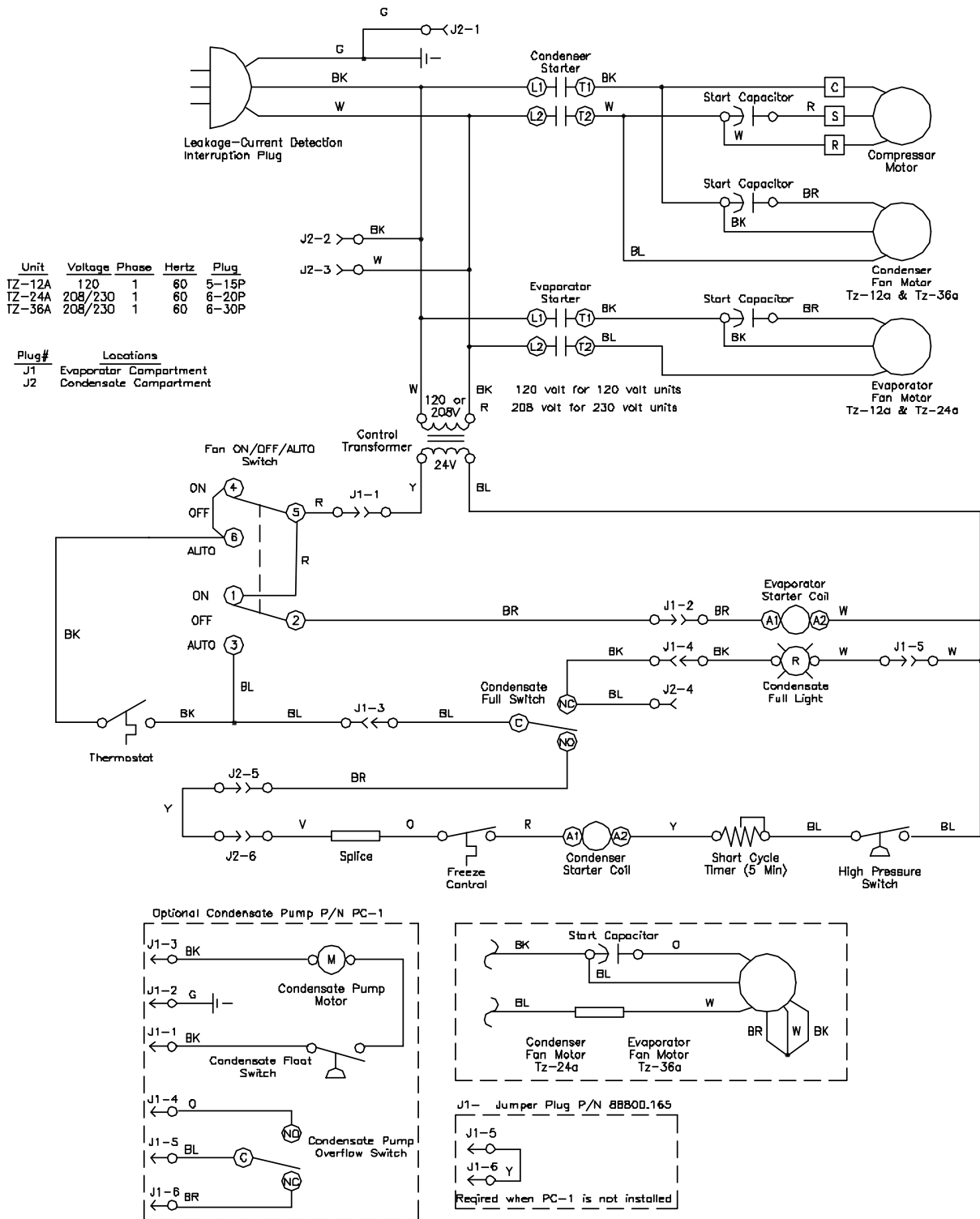



# Wiring Schematic, TZ-60AB

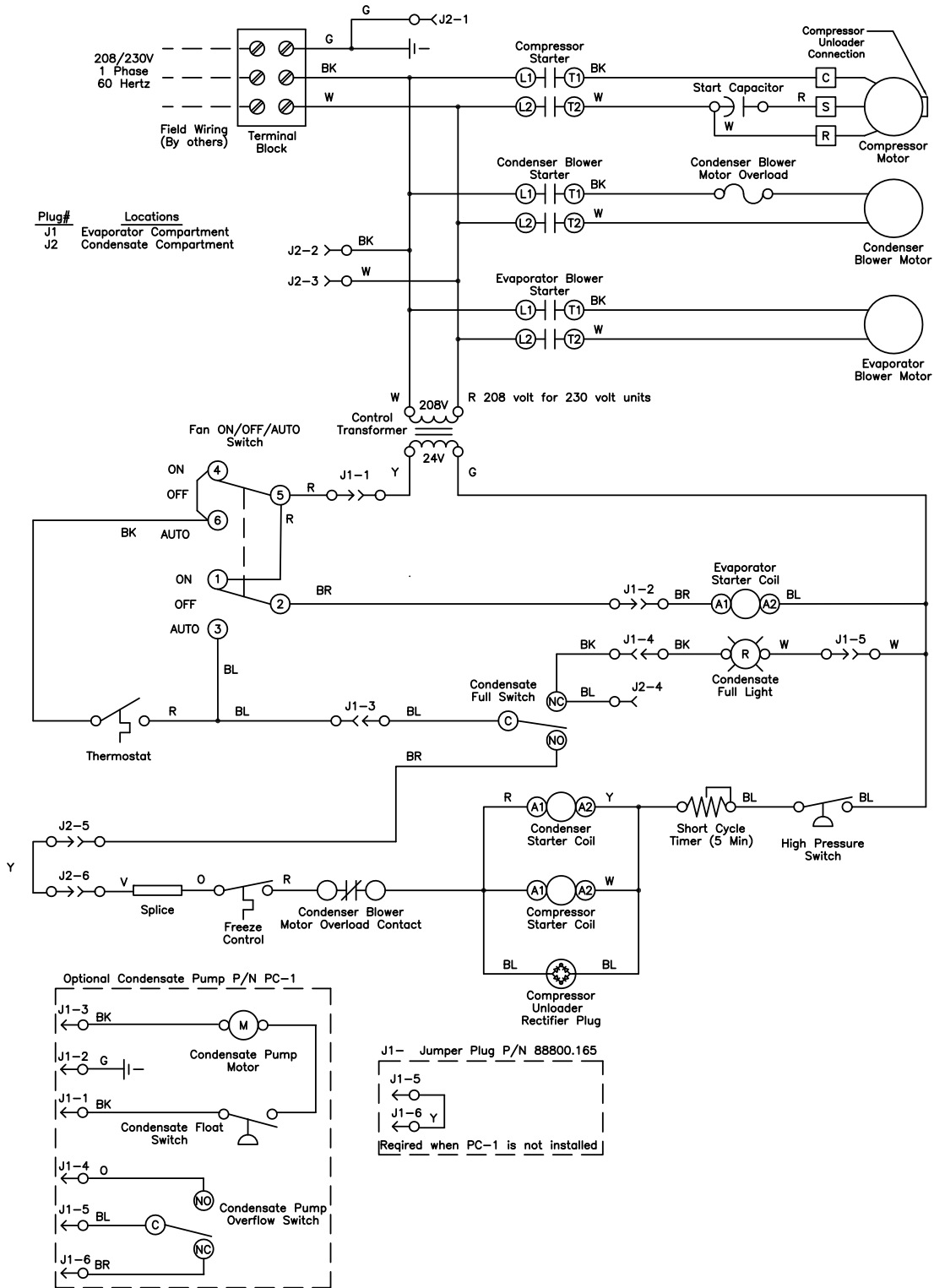

# Wiring Schematic, TZ-60AB4

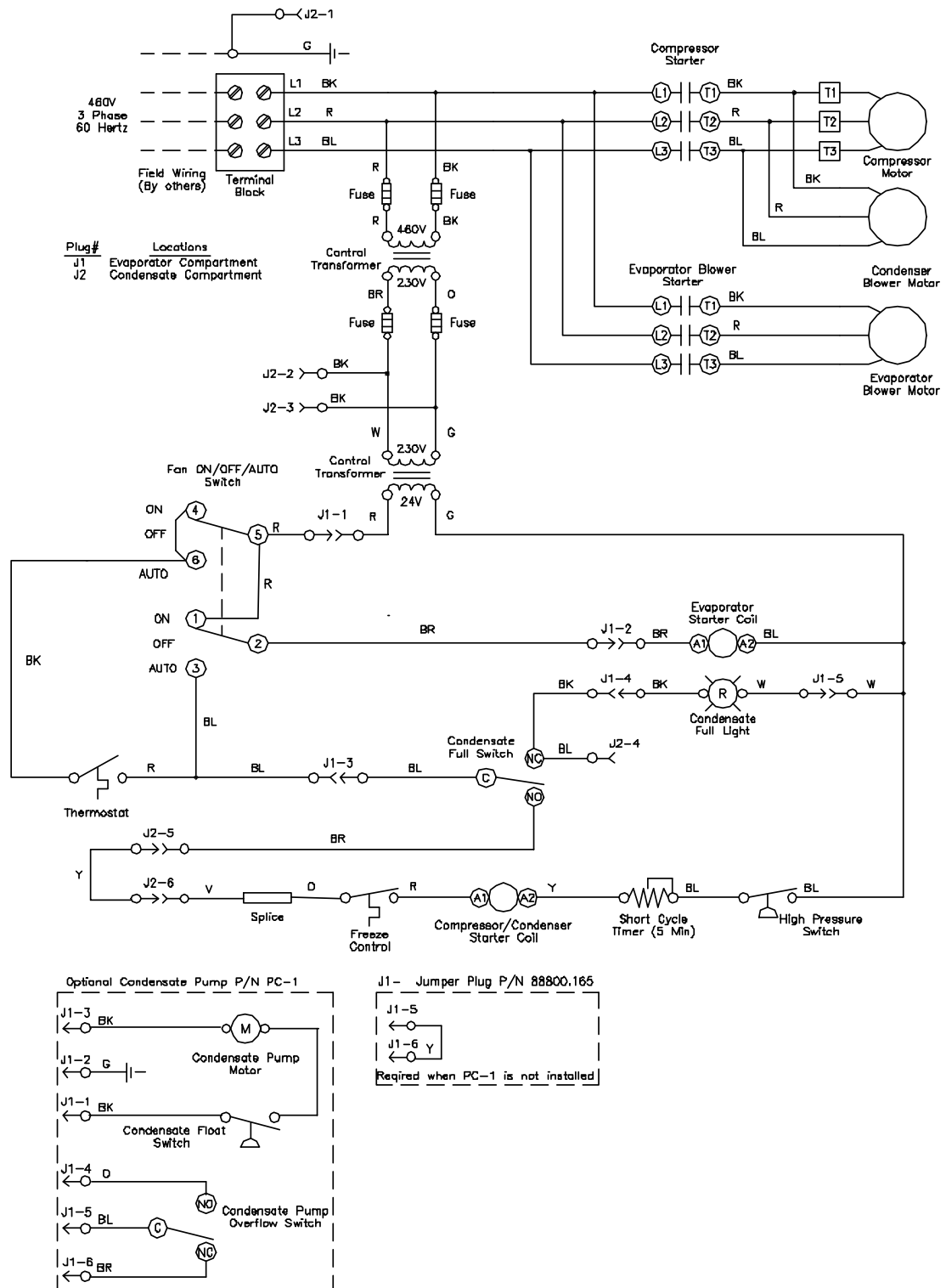

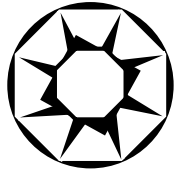

**TOPAZ<sup>®</sup>**

Portable Air Conditioners

TEMP-AIR  
3700 West Preserve Boulevard  
Burnsville, Minnesota 55337-7746

**1-800-836-7432**

89500.316

© 2010 TEMP-AIR, Inc.

Printed in USA