

# QP Series Model QP-7.5

Parts Manual  
Record of Change 203

This manual contains important safety information and must be carefully read in its entirety and understood prior to installation by all personnel who install, operate and/or maintain this product.

*On-line product registration, parts ordering and warranty information is available at [www.quincycompressor.com](http://www.quincycompressor.com)*

Manual No. 2022201401

July 2014 Edition

# TABLE OF CONTENTS

|   |       |
|---|-------|
| Serial Number Identification.....       | 2     |
| Ordering Replacement Parts .....        | 2     |
| Crankcase Lubricant Capacity .....      | 2     |
| Quin-Cip-D & Quin-Cip Lubricant .....   | 2     |
| Crankshaft Group.....                   | 3     |
| Crankcase Group.....                    | 4     |
| Sterling Blue Oil & Filters Kit .....   | 4     |
| Sterling Blue Ring Kit.....             | 5     |
| Connecting Rod & Piston Groups .....    | 5-6   |
| Cylinder & Head Groups .....            | 7-8   |
| Gasket Set.....                         | 8     |
| Sterling Blue Valve Kit .....           | 7     |
| Control Piping Schematics.....          | 9     |
| Pilot Valves.....                       | 10    |
| Differential Setting Chart .....        | 10    |
| Overhaul Kit .....                      | 10    |
| Suction Valve Unloader Assemblies ..... | 11    |
| Decals .....                            | 11    |
| Typical Unit Repair Parts List.....     | 12-14 |

# INTRODUCTION

This manual provides information for the Model QP-7.5 reciprocating compressor, per Record of Change 203.

The Model QP-7.5 is an aircooled, two stage, two cylinder, pressure lubricated compressor, with up to 175 PSI continuous pressure capability. It has a 4.5" low pressure bore and a 2.50" high pressure bore, with a 3" stroke. This compressor can be run at 500-1060 RPM.

# CHANGES

*Since previous printing dated December 2011:*

The bearing carrier is now equipped with a new oil filter.

## SERIAL NUMBER IDENTIFICATION

The unit serial number identification tag is located on the air tank top plate. The basic compressor serial number decal is located on the side of the crankcase opposite the oil fill side. *Fill in the numbers from your compressor unit and basic compressor in the corresponding spaces provided here, and reference this page when ordering replacement parts.*

|                     |
|---------------------|
| Unit Serial Number  |
| _____               |
| Basic Serial Number |
| _____               |

All replacement parts are to be ordered through an authorized Quincy distributor. Insist on genuine Quincy parts only! Failure to do so may void warranty.

## ORDERING REPLACEMENT PARTS

Prompt service can be rendered on repair parts orders if the following information is given:

- Item 1)** the model number, record of change number, & serial number.
- Item 2)** the exact part number needed. (Do not order by item numbers.)
- Item 3)** the exact quantity needed.
- Item 4)** the preferred type of transportation.

## CRANKCASE LUBRICANT CAPACITY

| Model  | Capacity                   |
|--------|----------------------------|
| QP-7.5 | 1 qt. - 26 oz. (1.72 lit.) |

## QUIN-CIP LUBRICANT

Refer to the chart below to order Quin-Cip-D or Quin-Cip lubricant from your local authorized Quincy distributor.

| <b>Quin-Cip-D<br/>Lubricant<br/>(synthetic)</b> |            |
|---|------------|
| <b>SAE 30 (ISO 100)</b>                         |            |
| Quart   | 115468Q    |
| Case (12 Qts.)                                  | 115468C    |
| <b>Quin-Cip Lubricant</b>                       |            |
| <b>SAE 10W (ISO 32)</b>                         |            |
| Quart   | 112541Q032 |
| Case (12 Qts.)                                  | 112541C032 |
| <b>SAE 20 (ISO 68)</b>                          |            |
| Quart   | 112542Q068 |
| Case (12 Qts.)                                  | 112542C068 |
| <b>SAE 30 (ISO 100)</b>                         |            |
| Quart   | 112543Q100 |
| Case (12 Qts.)                                  | 112543C100 |

**CAUTION !**  
Refer to the QP Industrial / Air Master Series instruction manual for vital lubrication information.

**CAUTION !**  
Follow all safety precautions outlined in the QP Industrial / Air Master Series instruction manual.

**WARNING !**  
Do not operate this compressor without a totally enclosed belt guard or any other required safety equipment.

**DANGER !**  
Air used for breathing or food processing must meet OSHA 1910.134 or FDA 21 CFR 178.3570 regulations. Failure to do so may cause severe injury or death.

# CRANKSHAFT GROUP 113684-009

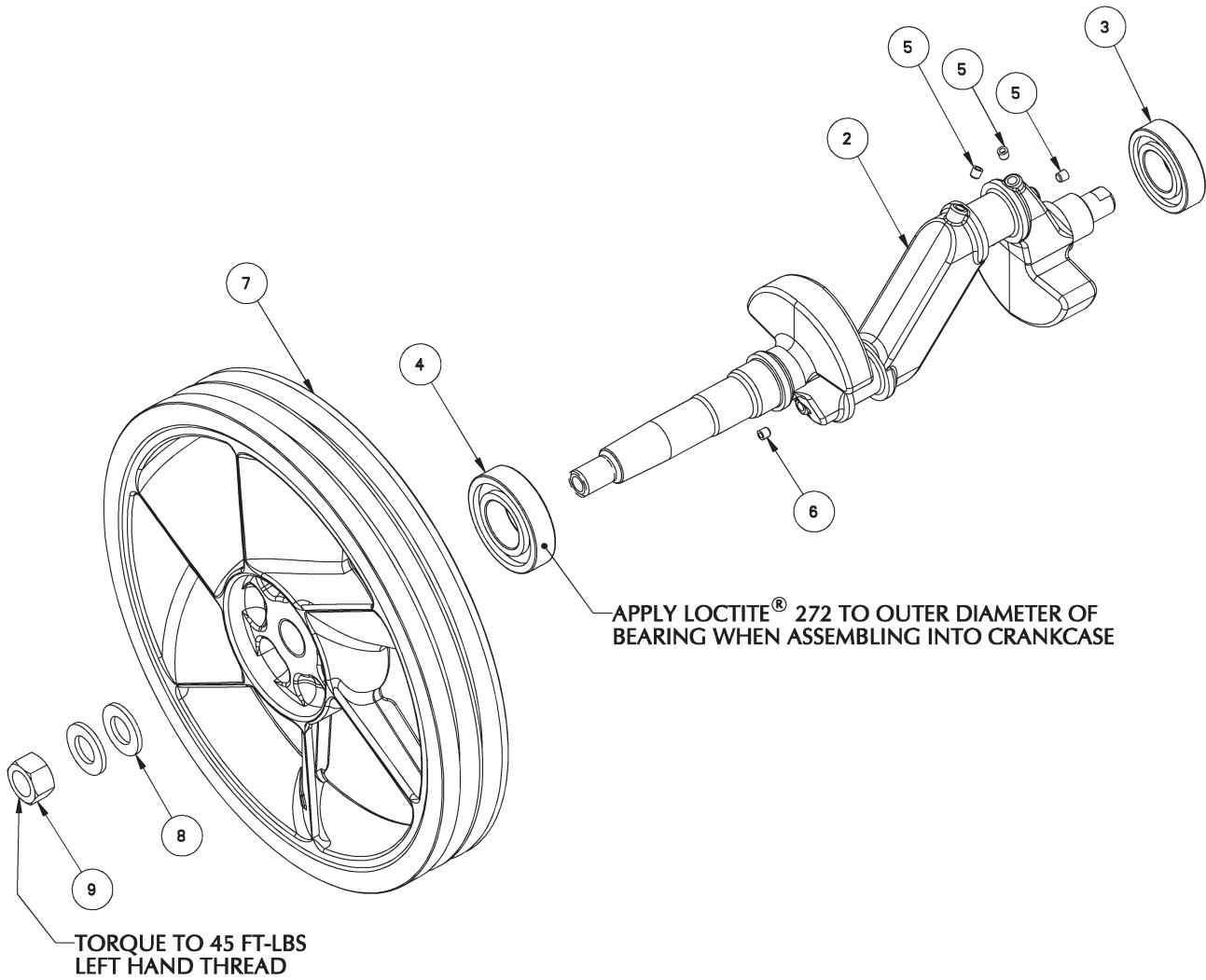

| ITEM | PART NUMBER | QTY | DESCRIPTION                                       |
|------|-------------|-----|---|
| 1    | 113602X005  | 1   | CRANKSHAFT ASSEMBLY (INCLUDES SHAFT AND BEARINGS) |
| 2    | 113602-005  | 1   | CRANKSHAFT (N.S.S. - ORDER CRANKSHAFT ASSEMBLY)   |
| 3    | 111107      | 1   | BALL BEARING                                      |
| 4    | 111780      | 1   | BALL BEARING                                      |
| 5    | 6565        | 3   | HOLE PLUG   |
| 6    | 6565-001    | 1   | ORIFICE, .031                                     |
| 7    | 113944-001  | 1   | SHEAVE, 14.15 O.D., 2 GROOVE, B SECT. CCW         |
| 8    | 110428N075  | 2   | FLAT WASHER, 3/4                                  |
| 9    | 114041      | 1   | HEX NUT, 3/4-16 UNF, L.H. THREAD                  |

N.S.S. = NOT SOLD SEPARATE

# CRANKCASE GROUP 2021060809

## Sterling Blue Oil & Filters Kit 2022103401

| Item # | Qty.  | Part Number | Description                    |
|--------|-------|-------------|--------------------------------|
| 1      | 1     | 110377E100  | air filter element             |
| 1      | 1     | 2023400100  | oil filter                     |
| 2 qt.  | 2 qt. | 115468Q     | Quin-Cip-D synthetic lubricant |

| ITEM | PART NUMBER | QTY | DESCRIPTION                       |
|------|-------------|-----|-----------------------------------|
| 1    | 113940-003  | 1   | CRANKCASE                         |
| 2    | 2276        | 1   | PIPE PLUG, 3/4 NPT                |
| 3    | 2057        | 2   | PIPE PLUG                         |
| 4    | 113736-050  | 1   | SIGHTGLASS, 1/2 NPT               |
| 5    | 113755      | 1   | BEARING CARRIER GASKET            |
| 6    | 113942-001  | 1   | BEARING CARRIER                   |
| 7    | 2755S       | 2   | PIPE PLUG, 1/8 NPT                |
| 8    | 115037-L14  | 5   | SCREW, CAP HEX, SEALANT, GRADE 5  |
| 9    | 113947      | 1   | BREATHER TUBE                     |
| 10   | 111333      | 1   | FILTER                            |
| 11   | 40825       | 1   | HOLE PLUG                         |
| 12   | 111106-001  | 1   | OIL SEAL, VITON                   |
| 13   | 110766      | 1   | OIL PUMP GEROTOR                  |
| 14   | 22749-012   | 1   | O-RING, VITON                     |
| 15   | 22749-152   | 1   | O-RING, VITON                     |
| 16   | 116366      | 1   | COVER PLATE                       |
| 17   | 110511-K12  | 4   | TAPITIE SCREW, 5/16-18 UNC X 1.00 |
| 18   | 2023400201  | 1   | FILTER ADAPTER STUD               |
| 19   | 2023400100  | 1   | OIL FILTER                        |
| 20   | 111151-002  | 1   | ADAPTER, 1/4M X 1/4F              |
| 21   | 110822      | 1   | OIL PRESSURE GAUGE                |
| 22   | 6882        | 1   | WASHER                            |
| 23   | 6579        | 1   | NUT, ADJUSTMENT SCREW             |
| 24   | 6578        | 1   | ADJUSTMENT SCREW                  |
| 25   | 22749-110   | 1   | O-RING, VITON                     |
| 26   | 111017      | 1   | SPRING                            |
| 27   | 1281        | 1   | BALL, OIL PUMP                    |
| 28   | 3100        | 1   | GASKET, OIL INLET FILTER          |
| 29   | 6517        | 1   | SCREW, OIL FILTER                 |
| 30   | 6576        | 1   | OIL INLET TUBE                    |
| 31   | 6518        | 1   | SCREEN, OIL INLET FILTER          |

| MAINTENANCE PARTS |   |
|-------------------|---|
| 111160            | OIL PUMP REPAIR KIT INCLUDES OIL PUMP GEROTOR AND O-RINGS |

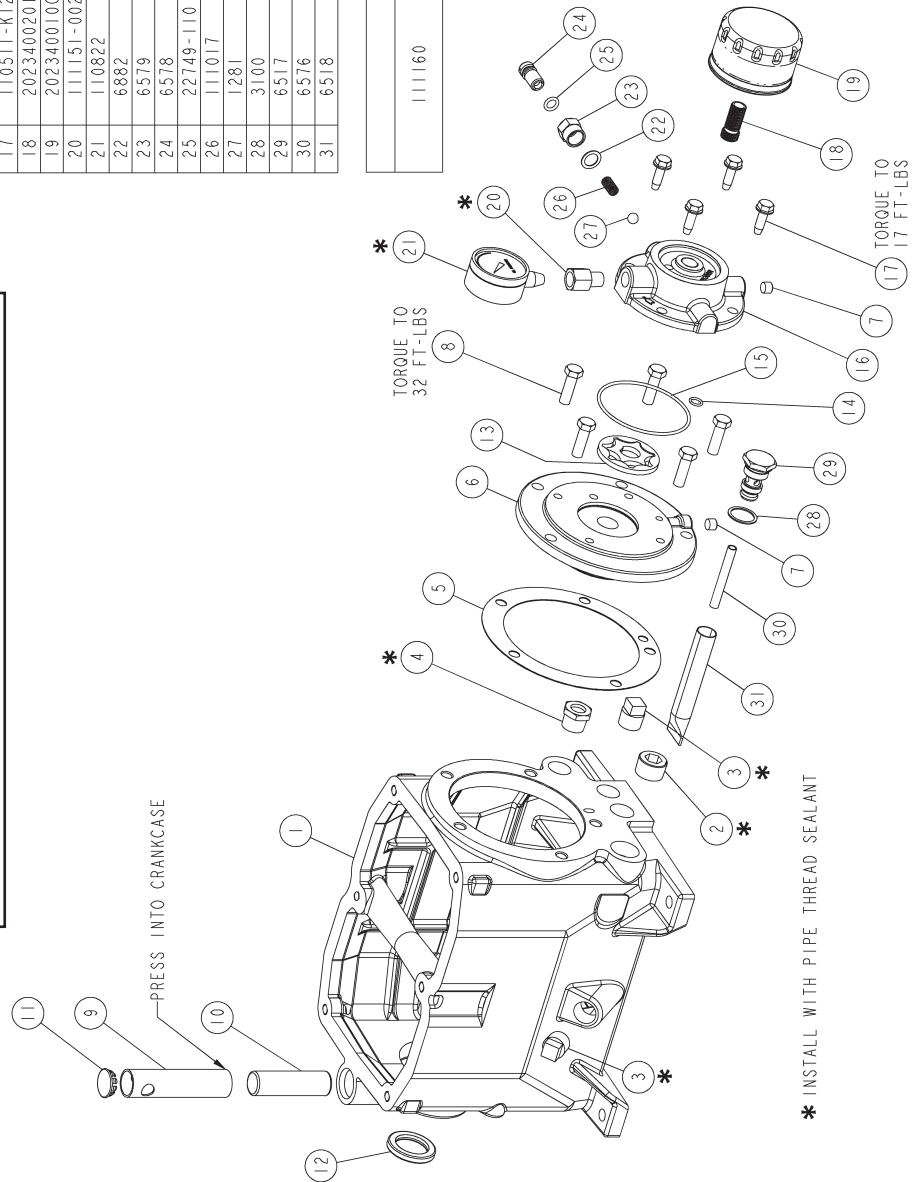

# CONNECTING ROD & PISTON GROUP 114192-002

(low pressure)

RING GAPS TO BE STAGGERED WHEN ASSEMBLED.  
PIP MARKS INDICATE TOP SURFACE OF RING.

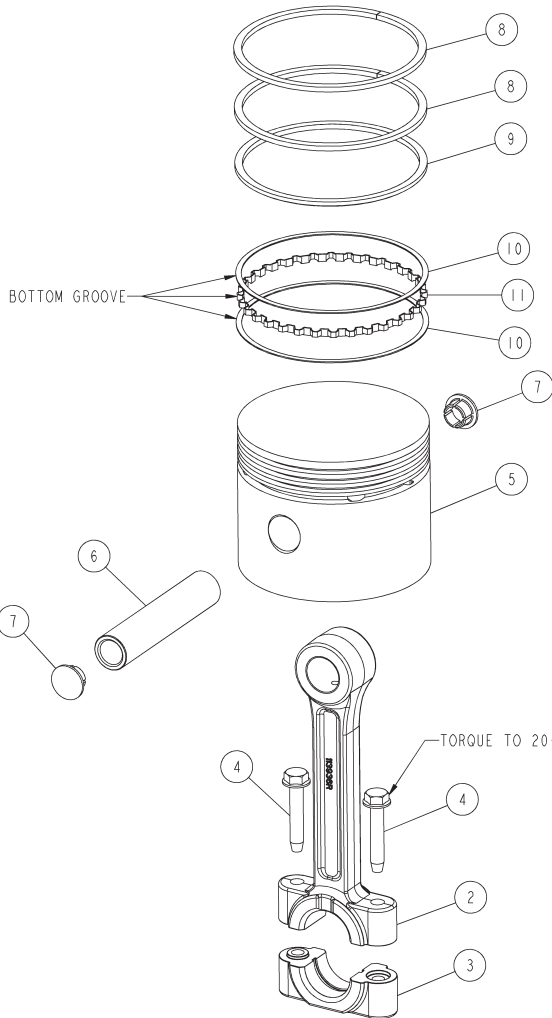

| LOW PRESSURE PISTON AND ROD GROUP 114192-002 BILL OF MATERIALS |             |   |   |
|--|-------------|---|---|
| ITEM   | PART NUMBER | QTY   | DESCRIPTION                                       |
| 1  | 113936-002  | 1   | CONNECTING ROD ASSEMBLY (INCLUDES ROD,CAP,SCREWS) |
| 2  | 113936      | 1   | CONNECTING ROD, N.S.S., ORDER ROD ASSEMBLY        |
| 3  | 113937      | 1   | CONNECTING ROD CAP, N.S.S., ORDER ROD ASSEMBLY    |
| 4  | 115388-K16  | 2   | HEX. SCREW, 5/16-18 UNC X 1.75, GRADE 8           |
| 5  | 8643        | 1   | PISTON, LP  |
| 6  | 110190-016  | 1   | PISTON PIN  |
| 7  | 111105-001  | 2   | PISTON PIN PLUG                                   |
| 8  | 2584        | 2   | RING, COMPRESSION, STANDARD                       |
| 9  | 7351        | 1   | PISTON RING                                       |
| 10   | 112781      | 2   | OIL RING RAIL                                     |
| 11   | 112780      | 1   | OIL RING EXPANDER                                 |
| MAINTENANCE PARTS  |             |   |   |
| PART NUMBER  | QTY         | DESCRIPTION   |   |
| 114209   | 1           | PISTON RING SET, LP   |   |
| 114208X  | 1           | PISTON ASSEMBLY, LP<br>INCLUDES PISTON, RING SET, PISTON PIN AND PISTON PIN PLUGS |   |

N.S.S. = NOT SOLD SEPARATE

| Sterling Blue Ring Kit<br>2022104500 |      |             |                 |
|--------------------------------------|------|-------------|-----------------|
| Item #                               | Qty. | Part Number | Description     |
| 1                                    |      | 114418      | gasket set      |
| 1                                    |      | 114209      | piston ring set |
| 1                                    |      | 114210      | piston ring set |
| 2                                    |      | 111105-001  | piston pin plug |
| 2                                    |      | 111105-002  | piston pin plug |



# CYLINDER & HEAD GROUP 2021061003

(less head unloaders)

| ITEM | PART NUMBER | QTY | DESCRIPTION                                      |
|------|-------------|-----|--|
| 1    | 113990      | 1   | CYLINDER   |
| 2    | 114005      | 1   | GASKET, VALVE PLATE TO CYLINDER                  |
| 3    | 113946X1    | 1   | VALVE PLATE ASSEMBLY                             |
| 4    | 113946M     | 1   | VALVE PLATE (N.S.S., ORDER VALVE PLATE ASSEMBLY) |
| 5    | 112380      | 1   | REED VALVE (N.S.S., ORDER V.P. ASSEMBLY)         |
| 6    | 112378-1    | 1   | BUMPER (N.S.S., ORDER V.P. ASSEMBLY)             |
| 7    | 112359-1    | 1   | REED VALVE (N.S.S., ORDER V.P. ASSEMBLY)         |
| 8    | 112381-1    | 1   | BUMPER (N.S.S., ORDER V.P. ASSEMBLY)             |
| 9    | 112359-2    | 2   | REED VALVE (N.S.S., ORDER V.P. ASSEMBLY)         |
| 10   | 112379      | 1   | BUMPER (N.S.S., ORDER V.P. ASSEMBLY)             |
| 11   | 112381-2    | 1   | BUMPER (N.S.S., ORDER V.P. ASSEMBLY)             |
| 12   | 112728-J12  | 4   | FLATHEAD SCR., 1/4-20UNC X 1.00, GR 8            |
| 13   | 112373-J02  | 4   | HEX NUT, 1/4-20 UNC                              |
| 14   | 113618-003  | 1   | GASKET, VALVE PLATE TO HEAD                      |
| 15   | 113613M001  | 1   | CYLINDER HEAD, PLAIN                             |
| 16   | 114595N038  | 7   | FLAT WASHER, 3/8                                 |
| 17   | 114440-L22  | 6   | HEX. SCREW, 3/8-16 UNC X 3.25, GRADE 9           |
| 18   | 113843      | 1   | GASKET, CYLINDER TO CRANKCASE                    |
| 19   | 2961-100    | 1   | PRESSURE RELIEF VALVE                            |
| 20   | 115037-L14  | 6   | SCREW, CAP HEX, SEALANT, GRADE 5                 |
| 21   | 110919-024  | 2   | TUBE FITTING, 90° ELBOW, 3/4"x3/4"AMP            |
| 22   | 113606      | 1   | INTERCOOLER (N.S.S., ORDER REPLACEMENT KIT)      |
| 23   | 112225-2    | 1   | INTERCOOLER CLAMP                                |
| 24   | 123478-L10  | 1   | HEX SCREW, 3/8-16 UNC X .75, GRADE 5             |

| MAINTENANCE PARTS |  |
|-------------------|--|
| PART NUMBER       | DESCRIPTION  |
| 114419-001        | VALVE ASSEMBLY REPLACEMENT KIT<br>INCLUDES ITEMS 2, 3, 14, 16, 17 AND INSTRUCTIONS |
| 113606K           | INTERCOOLER REPLACEMENT KIT<br>INCLUDES INTERCOOLER AND NUT/SLEEVE FITTINGS        |
| K0775HA           | HEAD REPLACEMENT KIT<br>INCLUDES REPLACEMENT VALVE ASSEMBLY AND AIR FILTER ELEMENT |
| 110375I00         | AIR FILTER / SILENCER  |
| 110375I01         | AIR FILTER / SILENCER (FOR ENGINE DRIVEN MODELS)                                   |
| 110375I00         | ELEMENT, AIR FILTER  |

N.S.S. = NOT SOLD SEPARATE  
 \* INSTALL WITH TEFLON TAPE

| Sterling Blue Valve Kit<br>2022103800 |      |             |             |
|---------------------------------------|------|-------------|-------------|
| Item #                                | Qty. | Part Number | Description |
|                                       | 1    | 110258B061  | drive belt  |
|                                       | 1    | 114419-001  | valve kit   |

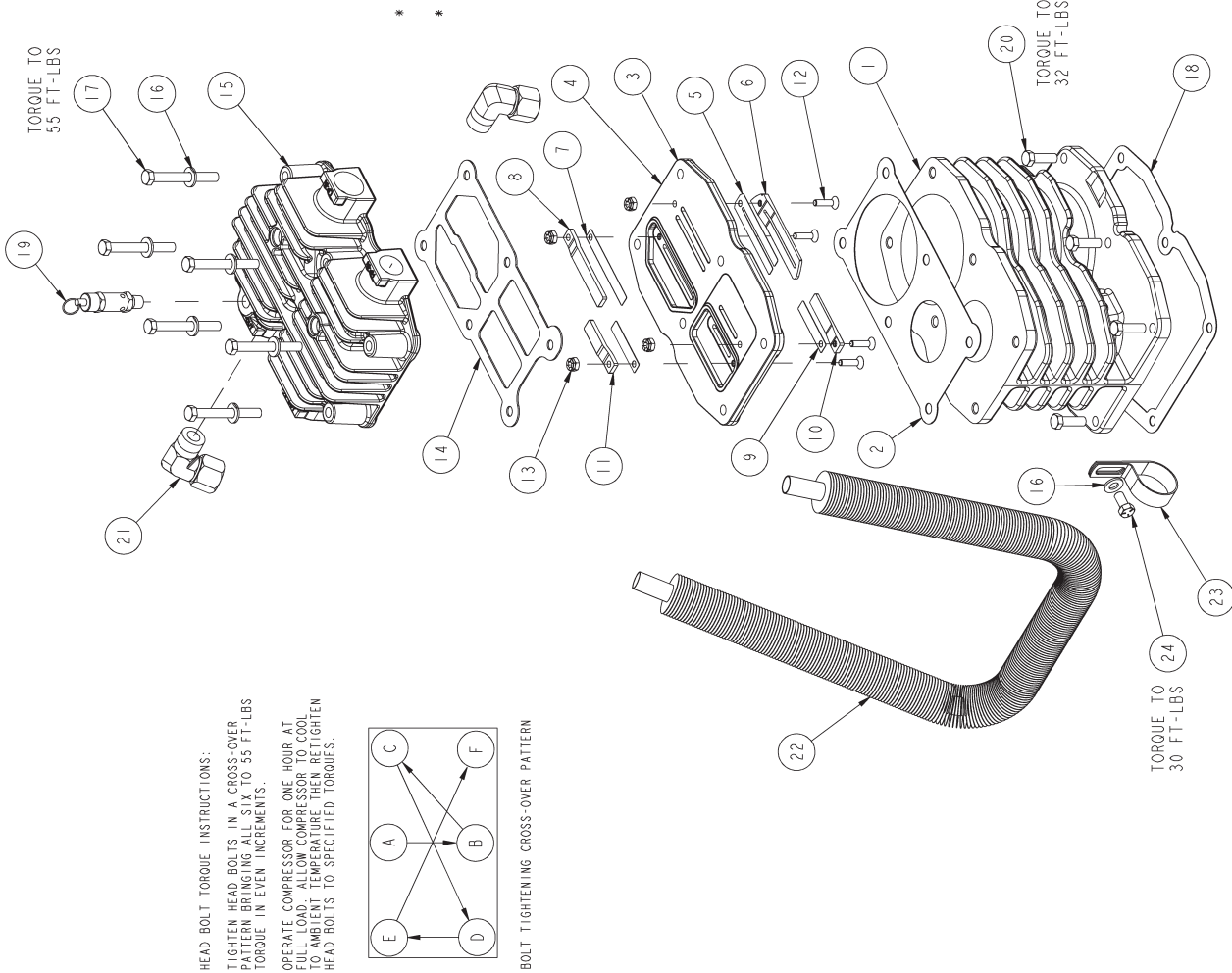

# CYLINDER & HEAD GROUP 2021061004

(with head unloaders)

| UNLOADER HEAD AND CYLINDER GROUP 113685-003 BILL OF MATERIALS |             |     |  |
|---|-------------|-----|--|
| ITEM  | PART NUMBER | QTY | DESCRIPTION                                      |
| 1   | 113990      | 1   | CYLINDER   |
| 2   | 114005      | 1   | GASKET, VALVE PLATE TO CYLINDER                  |
| 3   | 113946X1    | 1   | VALVE PLATE ASSEMBLY                             |
| 4   | 113946M     | 1   | VALVE PLATE (N.S.S., ORDER VALVE PLATE ASSEMBLY) |
| 5   | 112380      | 1   | REED VALVE (N.S.S., ORDER V.P., ASSEMBLY)        |
| 6   | 112378-1    | 1   | BUMPER (N.S.S., ORDER V.P., ASSEMBLY)            |
| 7   | 112359-1    | 1   | REED VALVE (N.S.S., ORDER V.P., ASSEMBLY)        |
| 8   | 112381-1    | 1   | BUMPER (N.S.S., ORDER V.P., ASSEMBLY)            |
| 9   | 112359-2    | 2   | REED VALVE (N.S.S., ORDER V.P., ASSEMBLY)        |
| 10  | 112379      | 1   | BUMPER (N.S.S., ORDER V.P., ASSEMBLY)            |
| 11  | 112381-2    | 1   | BUMPER (N.S.S., ORDER V.P., ASSEMBLY)            |
| 12  | 112728-J12  | 4   | FLATHEAD SCR, 1/4"-20UNC X 1.00, GR 8            |
| 13  | 112728-J02  | 4   | HEX NUT, 1/4"-20 UNC                             |
| 14  | 113618-003  | 1   | GASKET, VALVE PLATE TO HEAD                      |
| 15  | 113613-001  | 1   | CYLINDER HEAD, UNLOADER                          |
| 16  | 114595N038  | 7   | FLAT WASHER, 3/8"                                |
| 17  | 114440-L22  | 6   | HEX. SCREW, 3/8"-16 UNC X 3.25, GRADE 9          |
| 18  | 113943      | 1   | GASKET, CYLINDER TO CRANKCASE                    |
| 19  | 2961-100    | 1   | PRESSURE RELIEF VALVE                            |
| 20  | 115037-L14  | 6   | SCREW, CAP HEX, SEALANT, GRADE 5                 |
| 21  | 111591X1    | 1   | UNLOADER, INTAKE, LP                             |
| 22  | 111591X2    | 1   | UNLOADER, INTAKE, HP                             |
| 23  | 112708-908  | 2   | "O"RING, SILICONE                                |
| 24  | 2708        | 1   | TUBE FITTING, 90° ELBOW, 1/4"x1/4"AMP            |
| 25  | 124351-004  | 1   | MALE BRANCH TEE, 1/4" X 1/4"                     |
| 26  | 110919-024  | 2   | TUBE FITTING, 90° ELBOW, 3/4"x3/4"AMP            |
| 27  | 113606      | 1   | INTERCOOLER (N.S.S., ORDER REPLACEMENT KIT)      |
| 28  | 112225-2    | 1   | INTERCOOLER CLAMP                                |
| 29  | 123478-L10  | 1   | HEX SCREW, 3/8"-16 UNC X .75, GRADE 5            |

| MAINTENANCE PARTS |     |  |
|-------------------|-----|--|
| PART NUMBER       | QTY | DESCRIPTION  |
| 114419-001        | 1   | VALVE ASSEMBLY REPLACEMENT KIT<br>INCLUDES ITEMS 2, 3, 14, 16, 17 AND INSTRUCTIONS |
| 113606K           | 1   | INTERCOOLER REPLACEMENT KIT<br>INCLUDES INTERCOOLER AND NUT/SLEEVE FITTINGS        |
| R0775HA           | 1   | HEAD REPLACEMENT KIT<br>INCLUDES REPLACEMENT VALVE ASSEMBLY AND AIR FILTER ELEMENT |
| 110377S100        | 1   | AIR FILTER / SILENCER  |
| 110377S101        | 1   | AIR FILTER / SILENCER (FOR ENGINE DRIVEN MODELS)                                   |
| 110377E100        | 1   | ELEMENT, AIR FILTER  |

N. S. S. = NOT SOLD SEPARATE  
 \* INSTALL WITH TEFLON® TAPE

| Gasket Set 114418 |      |  |
|-------------------|------|--|
| Item #            | Qty. | Part Number Description                |
| 1                 | 1    | 113618-003 gasket, valve plate to head |
| 1                 | 1    | 113618-002 gasket, valve plate to head |
| 1                 | 1    | 114005 gasket, cylinder to valve plate |
| 1                 | 1    | 113943 gasket, crankcase to cylinder   |
| 1                 | 1    | 113755 gasket, bearing carrier         |
| 1                 | 1    | 111106-001 oil seal                    |

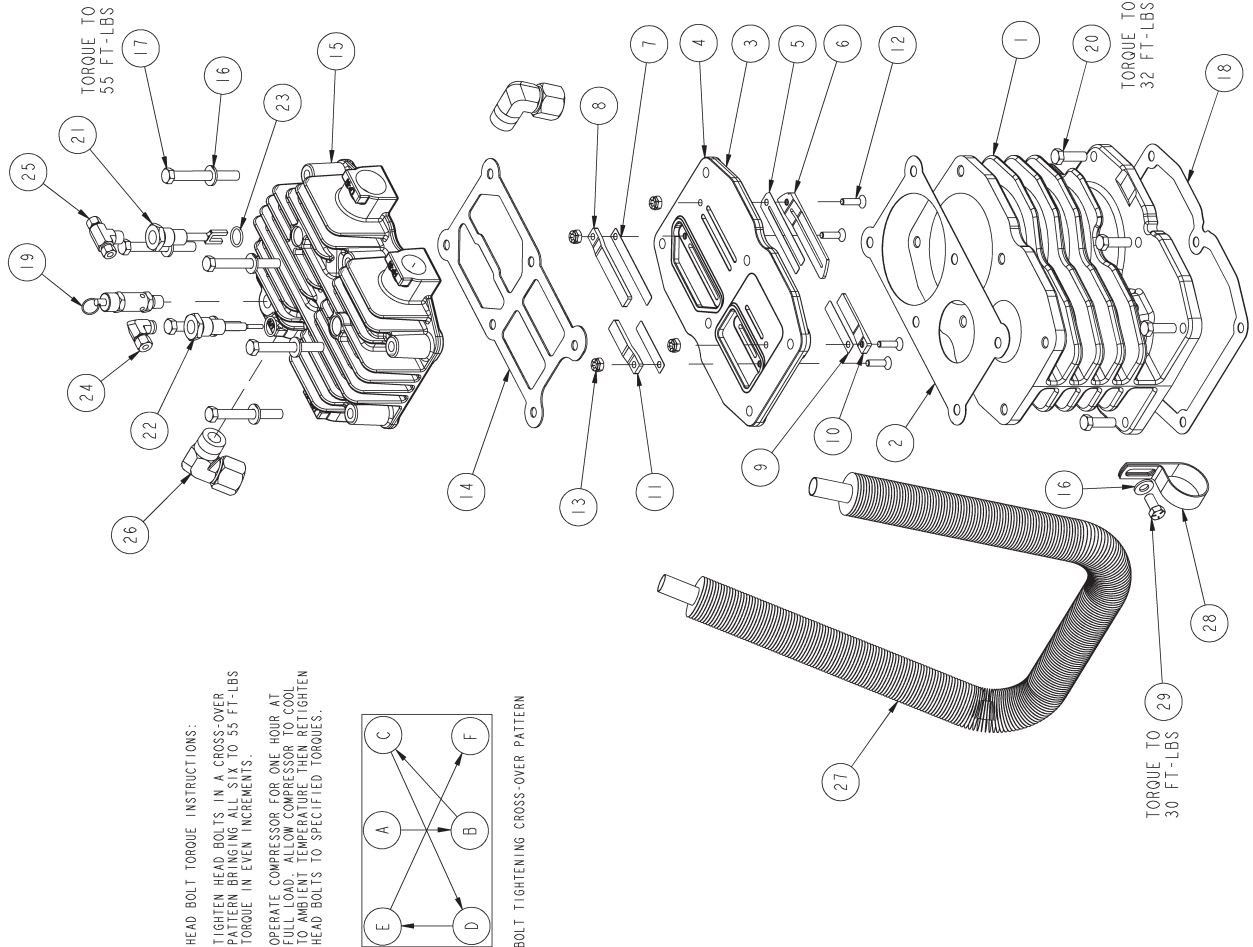

**HEAD BOLT TORQUE INSTRUCTIONS:**  
 TIGHTEN HEAD BOLTS IN A CROSS-OVER PATTERN BRINGING ALL SIX TO 55 FT-LBS TORQUE IN EVEN INCREMENTS.  
 OPERATE COMPRESSOR FOR ONE HOUR AT FULL OPERATING PRESSURE. ALLOW TO AMBIENT TEMPERATURE THEN RETIGHTEN HEAD BOLTS TO SPECIFIED TORQUES.

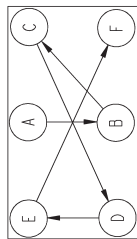

BOLT TIGHTENING CROSS-OVER PATTERN

# CONTROL PIPING SCHEMATICS

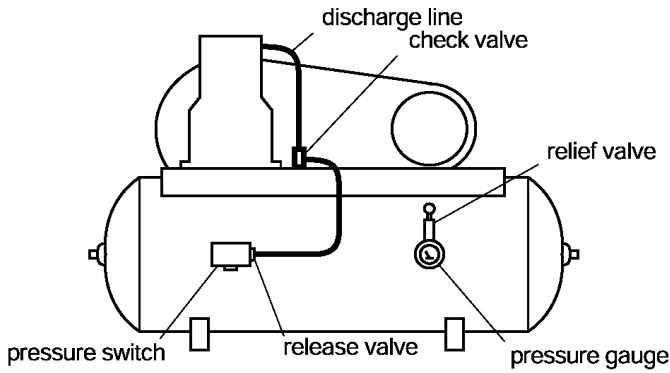

**Control Piping  
For Automatic Start/Stop**

*(with loadless starting)*

**Control Piping  
For Continuous Run**

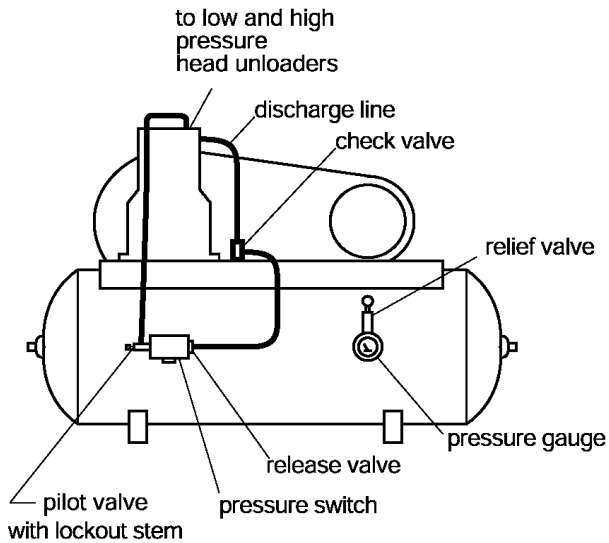
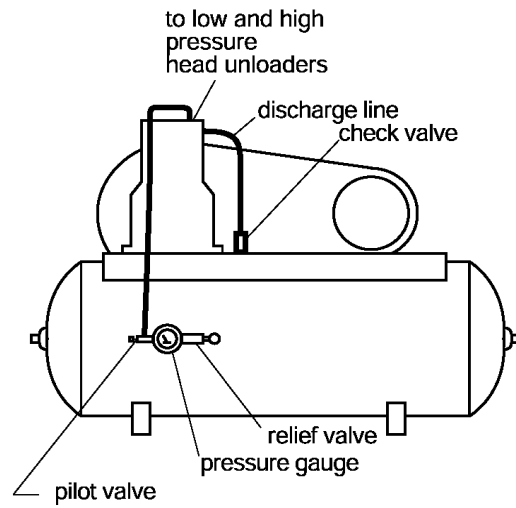

**Control Piping  
For Dual Control**

*For Start / Stop operation  
the pilot valve is open  
(stem screwed out)*

*For Continuous Run operation  
the pilot valve is closed  
(stem screwed in)*

# PILOT VALVES

**113708 Series Pilot Valve (continuous run operation)**  
 Add dash # listed below to 113708 (per pressure setting) to obtain correct pilot valve.

| Dash # | Load PSI | Unload PSI |
|--------|----------|------------|
| -050   | 40       | 50         |
| -075   | 65       | 75         |
| -100   | 80       | 100        |
| -100A  | 90       | 100        |
| -110   | 100      | 110        |
| -125   | 105      | 125        |
| -140   | 130      | 140        |
| -150   | 135      | 150        |
| -175   | 165      | 175        |

**110998 Series Pilot Valve (dual control operation)**  
 Add dash # listed below to 110998 (per pressure setting) to obtain correct pilot valve.

| Dash # | Load PSI | Unload PSI |
|--------|----------|------------|
| -045   | 35       | 45         |
| -070   | 50       | 70         |
| -085   | 75       | 85         |
| -095   | 75       | 95         |
| -100   | 90       | 100        |
| -110   | 100      | 110        |
| -115   | 100      | 115        |
| -140   | 125      | 140        |
| -140A  | 130      | 140        |
| -150   | 135      | 150        |
| -165   | 150      | 165        |
| -165A  | 155      | 165        |
| -175   | 165      | 175        |

**Differential Setting Chart**  
 Applies to 113708 & 110998 series pilot valves.

| Unload (PSI) | Min. Dif. (PSI) | Max. Dif. (PSI) |
|--------------|-----------------|-----------------|
| 40           | 2               | 5               |
| 60           | 3               | 10              |
| 100          | 4               | 20              |
| 150          | 5               | 30              |
| 175          | 5               | 45              |

**Overhaul Kit 2022101100**

| Item # | Qty. | Part Number | Description                 |
|--------|------|-------------|-----------------------------|
|        | 1    | 2022111301  | piston ring set, LP         |
|        | 1    | 2022111401  | piston ring set, HP         |
|        | 1    | 2022106800  | gasket set                  |
|        | 1    | 2024403751  | valve plate assembly        |
|        | 1    | 2023400852  | air filter element          |
|        | 1    | 2025024610  | piston pin                  |
|        | 1    | 2025024616  | piston pin                  |
|        | 1    | 2023402501  | breather filter             |
|        | 1    | 2024408303  | connecting rod assembly, LP |
|        | 1    | 2024408357  | connecting rod assembly, HP |
|        | 2    | 2025027201  | piston pin plug             |
|        | 2    | 2025027202  | piston pin plug             |
|        | 4    | 0147310022  | tapscrew                    |
|        | 4    | 5530605800  | capscrew                    |

**WARNING !**  
 Not all pilots are for use with all compressor systems. Make sure that the pilot you order is set within the safe operating limits of your compressor. Failure to heed this warning could result in an explosion.

# SUCTION VALVE UNLOADER ASSEMBLIES

## Description

The Quincy suction valve unloader assembly consists of unloading assemblies on the suction valves, having a plunger to contact the suction valve reed and an unloader pilot valve (113708 or 110998 series) to automatically regulate the passing of air tank pressure to the unloading arrangement.

## Continuous Run Operation

Suction valve unloader assemblies are recommended for use on Quincy compressors where the compressor is to run continuously and a constant pressure is to be maintained. The purpose is to automatically unseat the suction valve of the compressor when the air supply is greater than the demand.

Unloading occurs when air tank pressure is sufficient to overcome pilot valve spring pressure. The check ball is then unseated, allowing air tank pressure to pass to the unloader assemblies. The compressor will run unloaded until the air tank pressure drops to a predetermined level. At this time, the action of the ball is reversed, shutting off air tank pressure to the unloader assemblies and venting the unloader to atmosphere. This allows the compressor to load. The drive, either electric motor or engine, runs continuously and must be started and stopped manually. 113708 series pilot valves feature a toggle lever which can be flipped to provide manual unloading.

## Dual Control Operation

Dual control operation is designed to provide a choice between "start/stop" or "continuous run" operation. The 110998 series pilot valve can be set for "start/stop" operation by turning the knurled knob at the end of the pilot valve (refer to illustration for 110998 series pilot valve) clockwise until it stops. Under these circumstances, a pressure switch is required to stop the motor. Failure to use a pressure switch, with the pilot valve locked out, will result in unsafe conditions.

**WARNING !**

A pressure switch must be incorporated whenever 110998 series pilot valve is employed as part of the control system.

The compressor will operate in the continuous run mode if the knurled knob is turned counterclockwise until it stops.

## Installation

The pilot valve is mounted directly into the air tank. Compressors in the field, not equipped with these controls, can be converted. Consult your local Quincy distributor for assistance with conversion procedures.

## Service

If a change in pilot valve operation is detected, remove the pilot valve from the air tank and check the screen in the inlet of the pilot valve for obstructions. Clean the screen if necessary.

## Adjustment

The unloading pressure is adjustable and is regulated by turning the unload adjustment hex nut (refer to pilot valve illustrations). Turn the hex nut clockwise to increase and counterclockwise to decrease the unloading pressure.

The differential (difference between unloading and loading pressure) is set by turning the differential adjustment hex nut (refer to pilot valve illustrations). Increase the differential pressure by turning the hex nut clockwise - decrease by turning counterclockwise. Make all adjustments in small increments. Tighten the locknuts after adjustment.

## DECALS

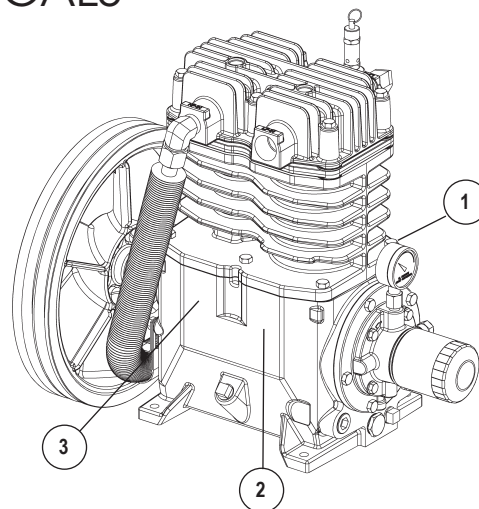

| Decals |      |             |                                    |
|--------|------|-------------|------------------------------------|
| Item # | Qty. | Part Number | Description                        |
| 1      | 1    | 110831      | serial number & nameplate          |
| 2      | 1    | 127889-A    | decal, CAUTION!, MANUAL            |
| 3      | 1    | 127889-B    | decal, DANGER!, "Air from this..." |

# TYPICAL UNIT REPAIR PARTS LIST

The parts listed here are for *standard* QP-7.5 (up to 175 PSI) units and may or may not be applicable to custom built units. Check with your local authorized Quincy distributor for parts that can be used for custom built units. Make sure the components you order are rated within the safe operating limits of your system. If you are doubtful about which components to order, contact your local Quincy distributor.

(QP-7.5 simplex - horizontal tank - electric motor)

| Qty | Part Number         | Part Number       | Part Number         | Description  |
|-----|---------------------|-------------------|---------------------|--|
|     | <b>80 gal.</b>      | <b>120 gal.</b>   |                     |  |
| 1   | 113268P200          | 113271P200        |                     | tank (200 PSI maximum operating pressure)          |
| 1   | 2713                | 111136-050        |                     | tank drain valve                                   |
| 1   | 111136-075          | 111136-100        |                     | service valve                                      |
| 1   | 110514-300          | 110514-300        |                     | pressure gauge                                     |
| 1   | 110512-005          | 110512-005        |                     | pressure switch                                    |
| 1   | 110513-200          | 110513-200        |                     | pressure relief valve (in tank; 200 PSI)           |
| 1   | 111089-215          | 111089-215        |                     | pressure relief valve (in discharge line; 215 PSI) |
| 1   | 111491              | 111491            |                     | check valve  |
| 1   | 114559-001          | 114559-001        |                     | discharge tube                                     |
| 2   | 110948-075          | 110948-075        |                     | tube fitting, nut with sleeve                      |
| 1   | <i>110945K017</i>   | <i>110945K017</i> |                     | belt guard assembly                                |
|     | <b>7.5 h.p.</b>     |                   |                     |  |
| 1   | <i>110258B061</i>   |                   |                     | drive belt   |
| 1   | <i>110828</i>       |                   |                     | motor pulley                                       |
| 1   | 8930                |                   |                     | motor bushing                                      |
|     | <b>115/230v, 1Ø</b> | <b>200v, 3Ø</b>   | <b>230/460v, 3Ø</b> |  |
| * 1 | <i>127466J018</i>   | <i>8393</i>       | <i>127466J029</i>   | 7.5 h.p. motor (ODP)                               |

\* 230 volt only

Part numbers shown in italics apply to tank mounted units and base mounted units.

(QP-7.5 duplex - horizontal tank - electric motor)

| Qty | Part Number         | Part Number       | Part Number         | Description  |
|-----|---------------------|-------------------|---------------------|--|
|     | <b>120 gal.</b>     | <b>200 gal.</b>   |                     |  |
| 1   | 113467P200          | 113469P200        |                     | tank (200 PSI maximum operating pressure)                  |
| 2   | 113281              | <i>113281</i>     |                     | top plate  |
| 1   | 111136-050          | 111136-050        |                     | tank drain valve   |
| 1   | 111136-100          | 111136-100        |                     | service valve  |
| 1   | 110514-300          | 110514-300        |                     | pressure gauge   |
| 2   | 110512-005          | 110512-005        |                     | pressure switch, 135-175 PSI                               |
| 1   | 110513-200          | 110513-200        |                     | pressure relief valve (in tank; 200 PSI)                   |
| 2   | 111089-215          | 111089-215        |                     | pressure relief valve (in discharge line; 215 PSI)         |
| 2   | 111491              | 111491            |                     | check valve  |
| 2   | 114559-001          | 114559-001        |                     | discharge tube (3/4" copper tube to be formed by customer) |
| 2   | 110948-075          | 110948-075        |                     | tube fitting, nut with sleeve                              |
| 2   | <i>110945K017</i>   | <i>110945K017</i> |                     | belt guard assembly  |
|     | <b>7.5 h.p.</b>     |                   |                     |  |
| 2   | <i>110258B061</i>   |                   |                     | drive belt   |
| 2   | <i>110828</i>       |                   |                     | motor pulley   |
| 2   | 8930                |                   |                     | motor bushing  |
|     | <b>115/230v, 1Ø</b> | <b>200v, 3Ø</b>   | <b>230/460v, 3Ø</b> |  |
| * 1 | <i>127466J018</i>   | <i>8393</i>       | <i>127466J029</i>   | 7.5 h.p. motor (ODP)                                       |

\* 230 volt only

Part numbers shown in italics apply to tank mounted units and base mounted units.

# TYPICAL UNIT REPAIR PARTS LIST

The parts listed here are for standard QP-7.5 (up to 175 PSI) units and may or may not be applicable to custom built units. Check with your local authorized Quincy distributor for parts that can be used for custom built units. Make sure the components you order are rated within the safe operating limits of your system. If you are doubtful about which components to order, contact your local Quincy distributor.

## (QP-7.5 vertical tank - electric motor)

| Qty | Part Number         | Part Number     | Part Number         | Description                               |
|-----|---------------------|-----------------|---------------------|---|
|     | <b>80 gal.</b>      | <b>120 gal.</b> |                     |   |
| 1   | 114949P200          | 114119P200      |                     | tank (200 PSI max. working pressure)      |
| 1   | 110425-025          | 110425-050      |                     | tank drain valve                          |
| 1   | 111136-075          | 111136-075      |                     | ball valve                                |
| 1   | 110514-300          | 110514-300      |                     | pressure gauge                            |
| 1   | 110512-005          | 110512-005      |                     | pressure switch (135-175 PSI)             |
| 1   | 110513-200          | 110513-200      |                     | pressure relief valve (in tank; 200 PSI)  |
| 1   | 114559-001          | 114559-001      |                     | discharge tube                            |
| 2   | 110948-075          | 110948-075      |                     | tube fitting, nut with sleeve             |
| 1   | 111491              | 111491          |                     | check valve                               |
| 1   | 111089-215          | 111089-215      |                     | relief valve (in discharge line; 215 PSI) |
| 1   | 110945K017          | 110945K017      |                     | belt guard assembly                       |
|     | <b>7.5 h.p.</b>     |                 |                     |   |
| 1   | 110258B061          |                 |                     | drive belt                                |
| 1   | 110828              |                 |                     | motor pulley                              |
| 1   | 8930                |                 |                     | motor bushing                             |
|     | <b>115/230v, 1Ø</b> | <b>200v, 3Ø</b> | <b>230/460v, 3Ø</b> |   |
| 1   | 127466J018          | 8393            | 127466J029          | 7.5 h.p. motor (ODP)                      |

\* 230 volt only.

## (QP-7.5 gasoline engine driven)

| Qty | Part Number   | Part Number  | Part Number | Description                               |
|-----|---------------|--------------|-------------|---|
|     | <b>Kohler</b> | <b>Honda</b> |             |   |
|     | <b>14 hp</b>  | <b>13 hp</b> |             |   |
| 1   | 113727P200    | 113727P200   |             | tank (200 PSI maximum operating pressure) |
| 1   | 111136-025    | 111136-025   |             | tank drain valve                          |
| 1   | 111136-050    | 111136-050   |             | ball valve                                |
| 1   | 110514-300    | 110514-300   |             | pressure gauge                            |
| 1   | 110513-200    | 110513-200   |             | pressure relief valve (in tank; 200 PSI)  |
| 2   | 110357B070    | 110258B070   |             | drive belt                                |
| 1   | 5629          | 5629         |             | engine pulley                             |
| 1   | 8927          | 8927         |             | engine pulley bushing                     |
| 1   | 113702K016    | 113702-011   |             | belt guard assembly                       |
| 1   | 113143-003    | 115418-1     |             | throttle control (bullwhip cable)         |
| 1   | 116518        | 113701-3     |             | engine group, (includes throttle control) |
| 1   | 114559-001    | 114559-001   |             | discharge tube                            |
| 2   | 110948-075    | 110948-075   |             | tube fitting, nut with sleeve             |
| 1   | 111089-215    | 111089-215   |             | relief valve (in discharge line; 215 PSI) |
| 1   | 110921-177    | 110921-177   |             | check valve                               |
| 1   | 113708-175    | 113708-175   |             | pilot (165-175 PSI)                       |

# TYPICAL UNIT REPAIR PARTS LIST

The parts listed here are for standard QP-7.5 (up to 175 PSI) units and may or may not be applicable to custom built units. Check with your local authorized Quincy distributor for parts that can be used for custom built units. Make sure the components you order are rated within the safe operating limits of your system. If you are doubtful about which components to order, contact your local Quincy distributor.

(QP-7.5 diesel engine driven)

| Qty | Part Number      | Part Number      | Part Number | Description  |
|-----|------------------|------------------|-------------|--|
|     | <b>base unit</b> | <b>tank unit</b> |             |  |
| 1   |                  | 113727P200       |             | tank (200 PSI)   |
| 1   | 113764           |                  |             | top plate  |
| 1   |                  | 111136-025       |             | tank drain valve   |
| 1   |                  | 111136-050       |             | ball valve   |
| 1   |                  | 110514-300       |             | pressure gauge   |
| 1   |                  | 110513-200       |             | pressure relief valve (200 PSI)                          |
| 2   | 110258B070       | 110258B070       |             | drive belt   |
| 1   | 110622           | 110622           |             | engine pulley  |
| 1   | 110623           | 110623           |             | engine pulley bushing                                    |
| 1   | 113702K010       | 113702K010       |             | belt guard assembly                                      |
| 1   | 113143-001       | 113143-001       |             | throttle control   |
| 1   | 114080-001       | 114080           |             | Yanmar engine group, 10 h.p. (includes throttle control) |
| 1   |                  | 114559-001       |             | discharge tube   |
| 2   |                  | 110948-075       |             | tube fitting, nut with sleeve                            |
| 1   |                  | 111089-215       |             | pressure relief valve (in discharge line; 215 PSI)       |
| 1   |                  | 110921-177       |             | check valve (discharge line)                             |
| 1   | 113708-175       | 113708-175       |             | pilot (165-175 PSI)                                      |

# QUINCY COMPRESSOR

## STANDARD TERMS AND CONDITIONS

**LEGAL EFFECT:** Except as expressly otherwise agreed to in writing by an authorized representative of Seller, the following terms and conditions shall apply to and form a part of this order and any additional and/or different terms of Buyer's purchase order or other form of acceptance are rejected in advance and shall not become a part of this order.

The rights of Buyer hereunder shall be neither assignable nor transferable except with the written consent of Seller.

This order may not be canceled or altered except with the written consent of Seller and upon terms which will indemnify Seller against all loss occasioned thereby. All additional costs incurred by Seller due to changes in design or specifications, modification of this order or revision of product must be paid for by Buyer.

In addition to the rights and remedies conferred upon Seller by this order, Seller shall have all rights and remedies conferred at law and in equity and shall not be required to proceed with the performance of this order if Buyer is in default in the performance of such order or of any other contract or order with seller.

**TERMS OF PAYMENT:** Unless otherwise specified in the order acknowledgment, the terms of payment shall be 1% 15, net forty-five (45) days after shipment. These terms shall apply to partial as well as complete shipments. If any proceeding be initiated by or against Buyer under any bankruptcy or insolvency law, or in the judgment of Seller the financial condition of Buyer, at the time the equipment is ready for shipment, does not justify the terms of payment specified, Seller reserves the right to require full payment in cash prior to making shipment. If such payment is not received within fifteen (15) days after notification of readiness for shipment, Seller may cancel the order as to any unshipped item and require payment of its reasonable cancellation charges.

If Buyer delays shipment, payments based on date of shipment shall become due as of the date when ready for shipment. If Buyer delays completion of manufacture, Seller may elect to require payment according to percentage of completion. Equipment held for Buyer shall be at Buyer's risk and storage charges may be applied at the discretion of Seller.

Accounts past due shall bear interest at the highest rate lawful to contract for but if there is no limit set by law, such interest shall be eighteen percent (18%). Buyer shall pay all cost and expenses, including reasonable attorney's fees, incurred in collecting the same, and no claim, except claims within Seller's warranty of material or workmanship, as stated below, will be recognized unless delivered in writing to Seller within thirty (30) days after date of shipment.

**TAXES:** All prices exclude present and future sales, use, occupation, license, excise, and other taxes in respect of manufacture, sales or delivery, all of which shall be paid by Buyer unless included in the purchase price at the proper rate or a proper exemption certificate is furnished.

**ACCEPTANCE:** All offers to purchase, quotations and contracts of sales are subject to final acceptance by an authorized representative at Seller's plant.

**DELIVERY:** Except as otherwise specified in this quotation, delivery will be F. O. B. point of shipment. In the absence of exact shipping instruction, Seller will use its discretion regarding best means of insured shipment. No liability will be accepted by Seller for so doing. All transportation charges are at Buyer's expense. Time of delivery is an estimate only and is based upon the receipt of all information and necessary approvals. The shipping schedule shall not be construed to limit seller in making commitments for materials or in fabricating articles under this order in accordance with Seller's normal and reasonable production schedules.

Seller shall in no event be liable for delays caused by fires, acts of God, strikes, labor difficulties, acts of governmental or military authorities, delays in transportation or procuring materials, or causes of any kind beyond Seller's control. No provision for liquidated damages for any cause shall apply under this order. Buyer shall accept delivery within thirty (30) days after receipt of notification of readiness for shipment. Claims for shortages will be deemed to have been waived if not made in writing with ten (10) days after the receipt of the material in respect of which any such shortage is claimed. Seller is not responsible for loss or damage in transit after having received "In Good Order" receipt from the carrier. All claims for loss or damage in transit should be made to the carrier.

**TITLE & LIEN RIGHTS:** The equipment shall remain personal property, regardless of how affixed to any realty or structure. Until the price (including any notes given therefore) of the equipment has been fully paid in cash, Seller shall, in the event of Buyer's default, have the right to repossess such equipment.

**PATENT INFRINGEMENT:** If properly notified and given an opportunity to do so with friendly assistance, Seller will defend Buyer and the ultimate user of the equipment from any actual or alleged infringement of any published United States patent by the equipment or any part thereof furnished pursuant hereto (other than parts of special design, construction, or manufacture specified by and originating with Buyer), and will pay all damages and costs awarded by competent court in any suit thus defended or of which it may have had notice and opportunity to defend as aforesaid.

**STANDARD WARRANTY:** Seller warrants that products of its own manufacture will be free from defects in workmanship and materials under normal use and service for the period specified in the product instruction manual. Warranty for service parts will be Ninety (90) days from date of factory shipment. Electric Motors, gasoline and diesel engines, electrical apparatus and all other accessories, components and parts not manufactured by Seller are warranted only to the extent of the original manufacturer's warranty.

Notice of the alleged defect must be given to the Seller, in writing with all identifying details including serial number, type of equipment and date of purchase within thirty (30) days of the discovery of the same during the warranty period.

Seller's sole obligation on this warranty shall be, at its option, to repair or replace or refund the purchase price of any product or part thereof which proves to be defective. If requested by Seller, such product or part thereof must be promptly returned to seller, freight prepaid, for inspection.

Seller warrants repaired or replaced parts of its own manufacture against defects in materials and workmanship under normal use and service for ninety (90) days or for the remainder of the warranty on the product being repaired.

This warranty shall not apply and Seller shall not be responsible or liable for:

- (a) Consequential, collateral or special losses or damages;
- (b) Equipment conditions caused by fair wear and tear, abnormal conditions of use, accident, neglect or misuse of equipment, improper storage or damage resulting during shipping;
- (c) Deviation from operating instructions, specifications or other special terms of sale;
- (d) Labor charges, loss or damage resulting from improper operation, maintenance or repairs made by person(s) other than Seller or Seller's authorized service station.

In no event shall Seller be liable for any claims whether arising from breach of contract or warranty or claims of negligence or negligent manufacture in excess of the purchase price.

**THIS WARRANTY IS THE SOLE WARRANTY OF SELLERS AND ANY OTHER WARRANTIES, WHETHER EXPRESS OR IMPLIED IN LAW OR IMPLIED IN FACT, INCLUDING ANY WARRANTIES OF MERCHANTABILITY AND FITNESS FOR PARTICULAR USE ARE HEREBY SPECIFICALLY EXCLUDED.**

**LIABILITY LIMITATIONS:** Under no circumstances shall the Seller have any liability for liquidated damages or for collateral, consequential or special damages or for loss of profits, or for actual losses or for loss of production or progress of construction, whether resulting from delays in delivery or performance, breach of warranty, negligent manufacture or otherwise.

**ENVIRONMENTAL AND OSHA REQUIREMENTS:** At the time of shipment of the equipment from the factory, Quincy Compressor / Ortman Fluid Power will comply with the various Federal, State and local laws and regulations concerning occupational health and safety and pollution. However, in the installation and operation of the equipment and other matters over which the seller has no control, the Seller assumes no responsibility for compliance with those laws and regulations, whether by the way of indemnity, warranty or otherwise.

June 30, 2003





Reciprocating / Systems: 217.222.7700  
E-mail: [info@quincycompressor.com](mailto:info@quincycompressor.com)  
Website: [quincycompressor.com](http://quincycompressor.com)

