



M25653D.7

Owner's Manual

Electric Portable Air Compressor

(115V/15A or 230V/7.5A, Single Phase/20 gallon, 2 HP)
(115V/15.3A or 230V/7.8A, Single Phase/20 gallon, 2 HP, Two Stage)

Instructions for Installation/Set-up, Operation, Maintenance, & Storage

NorthStar® Models 25653 and 25654 belt-driven compressors have a single stage 2-cylinder pump, made with heavy-duty cast iron cylinders for long life, and a compact design rated for 135 maximum PSI. NorthStar® Models 106694 belt-driven compressors have a two stage 2-cylinder pump, made with heavy-duty cast iron cylinders for long life, and a compact design rated for 175 maximum PSI. Their continuous-duty rating ensures long-lasting performance, and its cast iron pump head ensures superior heat dissipation.

Read and understand this Owner's Manual completely before using. Keep this manual for future review. Failure to properly set up, operate and maintain the compressor in accordance with this manual could result in serious injury or death to operator or bystanders.

WARNING: SPECIAL HAZARDS

- **Injection Injury:** High-pressure air stream can pierce skin and underlying tissues, leading to serious injury and possible amputation. Such an injection injury can result in blood poisoning and/or severe tissue damage.
 - **Flying Debris:** High-pressure air stream can cause flying debris and possible surface damage.
 - **Not For Breathing Air:** NorthStar compressors are NOT designed, intended, or approved for supplying breathing air. No compressed air should be used for breathing unless air is treated in accordance with applicable standards.
 - **Fire/Explosion:** Sparks from air powered tool heads or attachments can ignite fuel or other flammable liquids or vapors in the vicinity. Exceeding the maximum pressure for air tools or attachments could cause them to explode. Keep a fire extinguisher rated "ABC" nearby.
 - **Burns:** Compressor pump, motor and discharge tubing are hot surfaces that can cause burn injuries.
 - **Electric Shock:** Operating equipment in wet conditions or where not properly grounded can cause electric shock.
- Detailed safety information about these hazards appears throughout this manual.

Equipment Protection Quick Facts

Inspect Upon Delivery: FIRST! Inspect for missing or damaged components. See "Initial Set-Up" section for where to report missing or damaged parts.

Add Pump Oil: Pump is NOT shipped with oil. Check the pump oil level before starting. See "Prepare for Operation" section of this Owner's Manual for capacity and viscosity.

Use Mechanical Lifting Equipment: Compressor may be too heavy to handle manually. Use proper lifting equipment for unloading and moving to installation site.

Ensure Air Compressor is Electrically Connected Correctly: All wiring, grounding, and electrical connections must be made by a competent electrician. Install according to local and national codes.

Run Pump Unloaded for Break-in Period: Before initial use, open drain valve and run compressor for 30 minutes to break in pump parts.

Follow Maintenance Schedule: Pump, air filter, and tank require periodic inspection and servicing to provide efficient function and long life. See "Maintenance & Repair" for frequency of servicing.

Table of Contents

Equipment Protection Quick Facts	1
Table of Contents	2
About Your Air Compressor	4
Specifications	5
Component Identification	6
Safety Signal Words	7
Hazard Signal Word Definitions.....	7
Safety Labeling	8
Safety Decal Locations	8
Safety Decals	9
Initial Set-Up	10
Step 1. Inspect & Unpack	10
Step 2. Assembly	10
Step 3. Select Suitable Location	11
Operation	12
Follow Operation Safety Rules	12
Prepare for Operation	12
Check/Add Oil to the Pump	12
Proper Air Hose and Tool Use	13
Pressure Control Related Devices.....	13
Compressor - Tool Requirements.....	13
Attaching/Disconnecting Air Hose and Tools.....	13
Using Compressor for Spraying	14
Flammable Materials	14
Moisture in Compressed Air	14
Shutdown	14
Procedure	14
For Malfunction During Operation.....	14
Maintenance & Repair	15
Maintenance Schedule Summary	15
Detailed Instructions – Maintenance & Repair	15
Inspect Safety/Relief Valve	15
Inspect Air Filter	15
Inspect Compressor for Air Leaks	15
Change Pump Oil	16
Drain Receiver Tank and Inspect Tank.....	16
Check Drive Belt for Tension and Alignment.....	16
Keep Compressor Clean.....	17
Cylinder Head Bolt Torque Specification.....	17
Troubleshooting	18
Parts Explosions – Model 25653 Rev D.7	19
Parts List – Model 25653 Rev D.7	20
Parts Explosions – Model 25654 Rev D.7	21

Parts List – Model 25654 Rev D.7	22
788876 Pump Explosion Rev D.7	23
788876 Pump Parts List Rev D.7	24
788876 Pump Kits Rev D.7	24
Parts Explosions-Model #106694	25
Parts List – Model #106694	26
Parts Explosions- Pump for Model #106694	27
Parts List - Model #106694	28
Appendix A: Lubricants and Compatibility.....	29
Alternate Lubricants.....	29
Limited Warranty.....	30

About Your Air Compressor

Thank you for purchasing a NorthStar air compressor! It is designed for long life, dependability, and top performance.

Intended Use. Provides compressed air used primarily for operating air tools and pressurizing other objects that require high air pressure, such as tires. Do not use for low-pressure objects such as balloons, air mattresses, and sport balls, which can explode quickly and easily. Special precautions are necessary when used for cleaning to prevent flying debris hazards. It is not to be used to supply breathing air.

Supplies Required. Normal operation will require you to supply:

- Compressor pump oil
- Personal protection equipment

See “*Specifications*” section for more detail.

Site Location. Intended for indoor use.

Personal Protection. Wear safety apparel during operation, including safety glasses with side and top protection.

Adult Control Only. Only trained adults should set up and operate the air compressor. Do not let children operate.

Under The Influence. Never operate, or let anyone else operate, the air compressor while fatigued or under the influence of alcohol, drugs, or medication.

Keep this manual for reference and review.

ATTENTION: Rental Companies and Private Owners who loan this equipment to others!

All persons to whom you rent/loan this air compressor must have access to and read this Owner's Manual. Keep this manual with the air compressor at all times and advise all persons who will operate the machine to read it. You must also provide personal instruction on how to safely set-up and operate the air compressor and remain available to answer any questions a renter/borrower might have. Owner's Manuals are available from NorthStar at 1-800-270-0810.

Specifications

MODEL			
Model #	25653	25654	106694
FLOW OUTPUT			
Max. Pressure Rating	135 PSI	135 PSI	175 PSI
Volume Rating	4.8 CFM @100 PSI 5.0 CFM @ 90 PSI 6.0 CFM @ 40 PSI	4.8 CFM @100 PSI 5.0 CFM @ 90 PSI 6.0 CFM @ 40 PSI	5.0 CFM @175 PSI 5.3 CFM @ 90 PSI 5.4 CFM @ 40 PSI
Receiver Capacity	20 gal.	20 gal.	20 gal.
Power Requirements			
Dedicated NEMA Receptacles	5-15R	5-15R	5-15R
Volts	115V/230V	115V/230V	115V/230V
Amps	15A/7.5A	15A/7.5A	15.3A/7.8A
Motor			
Horsepower	2 HP	2 HP	2 HP
DIMENSIONS / COMPONENTS			
Length	22"	43"	24.4"
Width	23"	22"	21.3"
Height	43"	30"	42.5"
Weight	204 lbs.	207 lbs.	207 lbs.
SUPPLIES REQUIRED (not included)			
Pump Oil (not included)	SAE 30 non-detergent pump oil (#4043)	SAE 30 non-detergent pump oil (#4043)	SAE 30 non-detergent pump oil (#4043)
Pump Oil Capacity	16.9 oz.	16.9 oz.	33.8 oz.

Component Identification

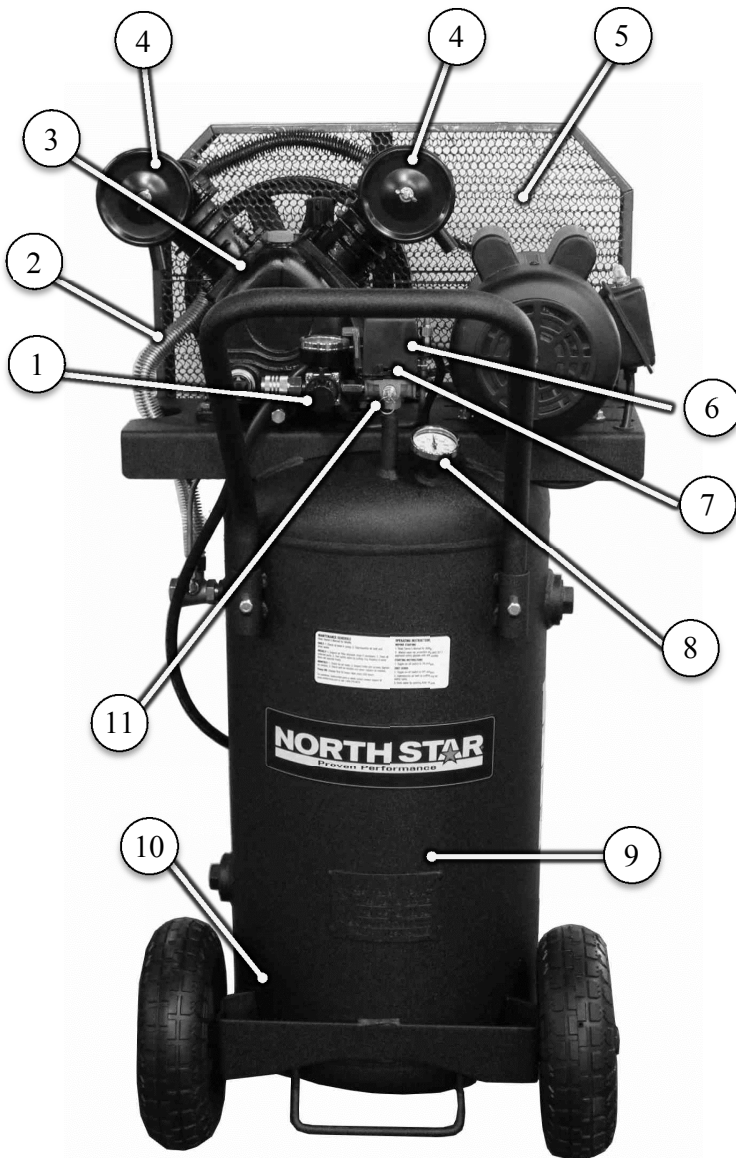

1. **Regulator:** Controls outlet pressure.
2. **Discharge Tube:** Carries compressed air from pump to safety/check valve, and then to the storage tank. It becomes very hot during use and can cause severe burns. Never touch.
3. **Air Compressor Pump:** Not shipped with oil.
4. **Compressor Air Filter:** Keep clean and particle free. See "Pump Explosion and Pump Parts List" for replacement part number.
5. **Belt Guard:** Covers belt, engine pulley and flywheel. NEVER operate compressor without belt guard in place.
6. **Unloader:** Vents discharge air to atmosphere in start/stop operation.
7. **Pressure Switch-Auto/Off switch:** In AUTO
 - a. position, compressor shuts off automatically when tank pressure reaches maximum preset pressure. In OFF position, compressor will not operate. Switch should be in OFF position when connecting or disconnecting power cord from electrical outlet. NEVER attempt to adjust this pressure switch.
8. **Pressure Gauge:** Air filled gauge. Shows pressure in receiver tank.
9. **Air Receiver / Storage Tank:** 20 gallon ASME certified tank.
10. **Tank Drain Valve:** Used to remove moisture from air after compressor is shut off and air emptied from tank. Drain moisture daily after each use.
11. **ASME Safety/Check Valve:** Automatically releases air if tank exceeds preset pressure max. of 200 PSI. A check valve is a pressure release port. Pull valve pin to relieve pressure from receiver tank.

Safety Signal Words

Hazard Signal Word Definitions



This is the safety alert symbol. It is used to alert you to potential personal injury hazards. Obey all safety messages that follow this symbol to avoid possible injury or death.



DANGER (red) indicates a hazardous situation, which if not avoided, will result in death or serious injury.



WARNING (orange) indicates a hazardous situation, which if not avoided, could result in death or serious injury.



CAUTION (yellow), used with the safety alert symbol, indicates a hazardous situation, which if not avoided, could result in minor or moderate injury.



CAUTION (yellow), without the safety alert symbol, is used to address practices not related to personal injury.



NOTICE is used to address practices not related to personal injury.

Safety Labeling

Safety Decal Locations

⚠ WARNING:

ALWAYS make sure safety labels are in place and in good condition. If a safety label is missing or not legible, order new labels from NorthStar Product Support at 1-800-270-0810.

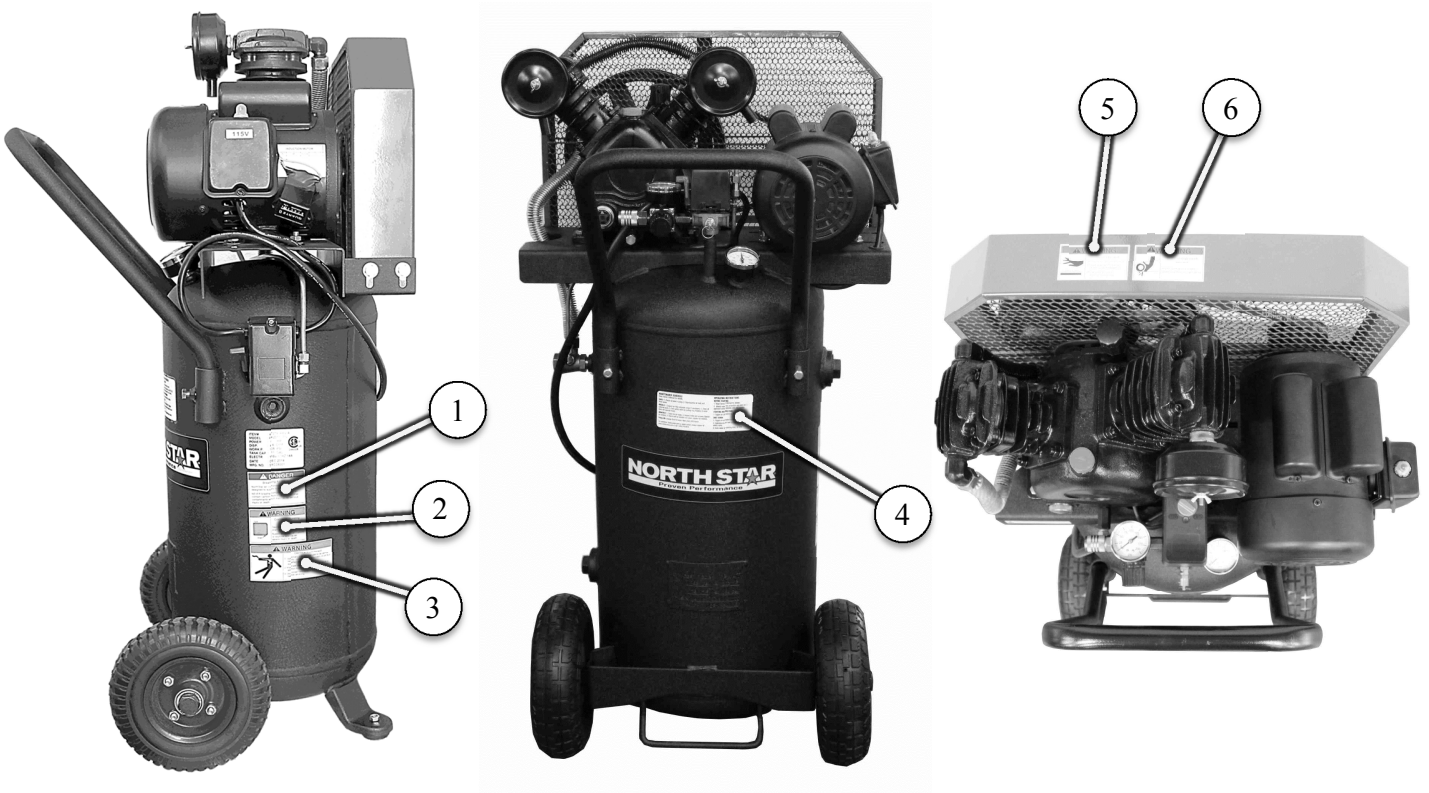

On-Product Warning Labels			
Location	Part numbers	Description	Model
1	792174	Breathing Hazard	All
2	792177	Corrosion Hazard	All
3	789060	Electrical Shock Hazard	All
4	792161	Air Compressor Instructions	All
5	792176	Burn Hazard	All
6	792175	Belt Hazard	All



Safety Decals

1

 DANGER
Breathing Air Hazard
NorthStar air compressors are NOT designed to supply breathing air.
NEVER breathe compressed air. It can contain carbon monoxide (CO) or other contaminants which may cause serious injury or death.



792174

2

 WARNING	
Corrosion Bursting Hazard	
	Depressurize air tank and drain water daily after use. Rusted air tanks can rupture or explode and cause severe injury or death.

792177



3

 WARNING	
Electrical Shock Hazard	
	<ol style="list-style-type: none"> 1. Improper electrical grounding can result in serious injury or death from electrocution. 2. Disconnect and lock out from power sources before servicing. 3. Do not expose compressor to rain or operate in a wet area. Store indoors.

4



<p>MAINTENANCE SCHEDULE Read Owner's Manual for details.</p> <p>DAILY: 1. Check oil level in pump. 2. Depressurize air tank and drain water.</p> <p>WEEKLY: 1. Inspect air filter element; clean if necessary. 2. Clean all external parts. 3. Test safety valve by pulling ring. Replace if valve does not operate freely.</p> <p>MONTHLY: 1. Check for air leaks. 2. Inspect bolts and screws; tighten as needed. 3. Check belt for tension and wear; replace as needed.</p> <p>Pump Oil: Change first 50 hours, then every 500 hours.</p> <p style="font-size: small;">For questions, replacement parts or labels contact product support at www.northerntool.com or call 1-800-270-0810.</p>	<p>OPERATING INSTRUCTIONS BEFORE STARTING</p> <ol style="list-style-type: none"> 1. Read Owner's Manual for details. 2. Always wear ear protection and ANSI Z87.1 approved safety glasses with side shields. <p>STARTING INSTRUCTIONS</p> <ol style="list-style-type: none"> 1. Toggle on-off switch to ON position. <p>SHUT DOWN</p> <ol style="list-style-type: none"> 1. Toggle on-off switch to OFF position. 2. Depressurize air tank by pulling ring on safety valve. 3. Drain water by opening drain on tank.
---	--

5

 WARNING	
Burn Hazard	
	Hot pump - Do not touch. Pump may be hot even if the unit is stopped. Allow unit to cool before servicing.

792176

6

 WARNING	
Belt Entanglement Hazard	
	KEEP belt guard in place while machine is operating.

792176

To order replacement safety labels, call NorthStar Product Support at 1-800-270-0810.

Initial Set-Up

Step 1. Inspect & Unpack

Upon receipt, inspect air compressor for missing or damaged parts. Verify that it is the compressor you ordered.

See “*Component Identification*” section of this manual for a diagram of the compressor and its components.

- For *missing* components, contact Product Support at 1-800-270-0810.
- For *damaged* components, contact the freight company that delivered the unit and file a claim.
- If complete, fill out product serial number information. See “*Limited Warranty*” section of this manual.

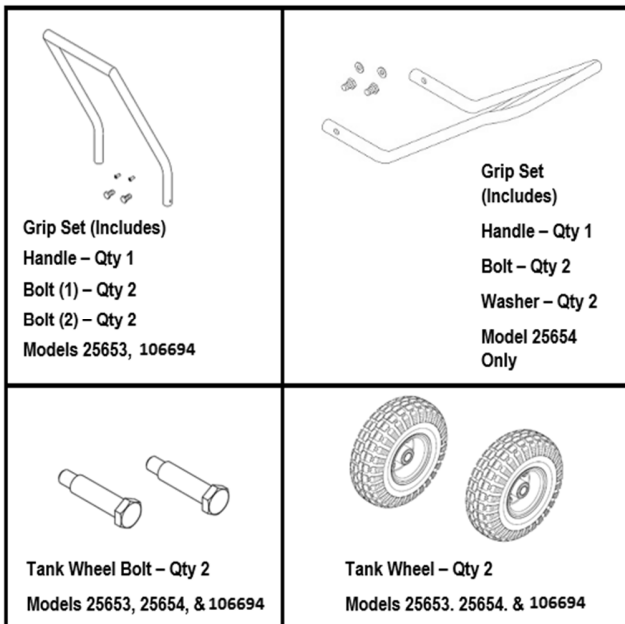

Figure 1

Step 2. Assembly

Models 25653 & 106694

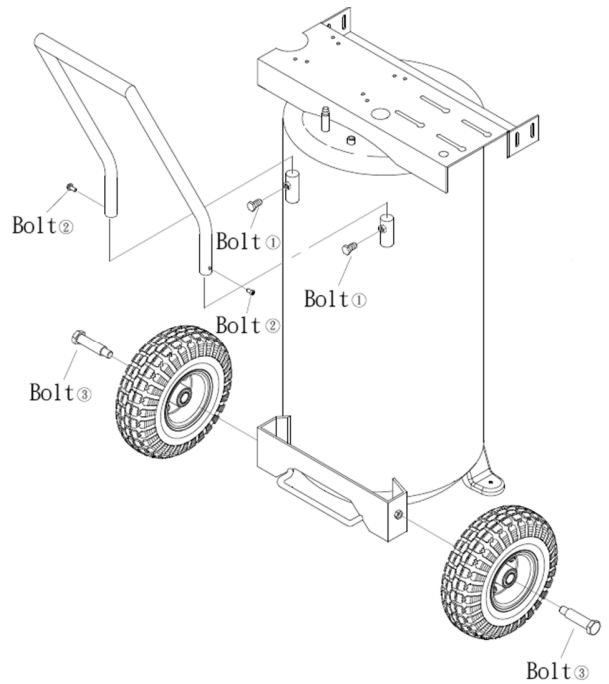

Figure 2

Model 25654

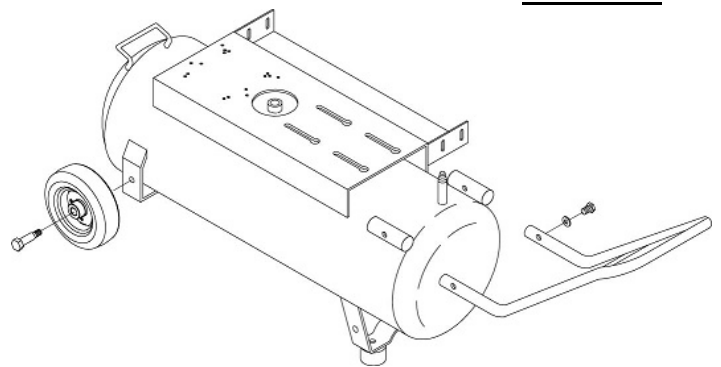

Figure 3

Step 3. Select Suitable Location



WARNING: Lifting hazard

The compressor is heavy. Ensure that proper lifting equipment is available to unload and move compressor to installation site.

Location Criteria:

- Where no flammable vapors, dusts, and gases are present.
- At least 18" away from walls and other objects.
- Away from other heat-generating equipment.
- Away from dusty/dirty conditions.
- In a well illuminated area.
- Where proper wire size is already, or can be made, available.

Positioning:

- The compressor should be mounted on a dry, firm, and level surface. It must sit level and be stabilized since it will slide or shift during operation if not secured.

Airflow:

- Provide access to adequate, clean and unobstructed airflow for cooling and air supply.
- Remember the supply air is passing through the compressor supply hoses and tools. These can be damaged or have a shortened life if unclean air is present or air filter is not clean and functioning properly.
- Do not allow debris to accumulate or block airflow.
- Do not operate with a tarp, blanket, or cover surrounding the machine, which blocks air flow.
- Do not place any objects against or on top of the unit, which can also block airflow or damage unit.

Electrical:

- MUST be connected to a 115V/230 Volt, single-phase outlet having operating capacity of 15 amps on 115V or 7.5 amps on 230V.

Wiring:

- Proper wire size should take into consideration length from distribution panel.

Extension Cords:

It is preferable to use an additional air hose whenever possible instead of an extension cord to avoid a voltage drop and/or power loss to motor, and to prevent overheating. If an extension cord must be used, ensure it meets the following criteria:

- 3-wire cord with 3-blade grounded plug, placed into a 3-slot wall receptacle that will accept the plug on the unit
- Cord must be in good condition
- Cord cannot be longer than 50 feet
- 12-gauge or larger

Ideal operating temperatures:

- 40° and 100°F (4° and 37°C).

Operating Limitations:

- 15°F (-9°C) or above 125°F (52°C).

If temperatures consistently drop below 32° F (0°C), install within a heated building. If this is not possible, protect the safety/relief and drain valves from freezing.

Note: Excessive moisture is likely to occur if unit is stored in an unheated area subject to large temperature changes. Moisture forming in pump can produce sludge in the oil, causing parts to wear out prematurely. Excessive condensation on the pump when it cools down is a sign that this may be occurring.

Operation

Follow Operation Safety Rules

Before starting the compressor, review the safety rules found below and throughout the manual.

WARNING

Failure to follow safety rules may result in serious injury or death to the operator or bystanders.

Instruct Operators. Owner must instruct all operators in safe set-up and operation. Do not allow anyone to operate the compressor who has not read the Owner's Manual.

Safety Guarding. Only operate with safety covers, guards and barriers secured and in good working order.

Moving Parts. Keep hands, feet, hair and apparel away from moving parts. Never remove any guards while the unit is operating. Do not reach into an air vent or cavity, as they may cover dangerous moving parts.

Ear Protection. Hearing can be damaged from prolonged, close-range exposure to the noise level produced by this compressor. Ear plugs or other hearing protection is recommended for persons working who are exposed within 15-20 feet of the running compressor for an extended period of time.

Eye Protection. Wear ANSI/OSHA required "Z87.1" safety glasses when operating or servicing the compressor. Pressurized air spray from this unit can cause severe injury to the eyes. Also, small objects will become airborne as the air spray contacts them.

Respirator. Wear a respirator when using the compressed air for spraying. Spray in a well-ventilated area to prevent health and fire hazards.

Prepare for Operation

Make sure that any regular maintenance has been performed as prescribed in the "Maintenance & Repair" section.

- Drain receiver tank of any moisture.
- Inspect for oil leaks.
- Check for any unusual noise/vibration.
- Ensure the area around compressor is free from rags, tools, debris and flammable or explosive materials.
- Ensure belt guards and covers are securely in place.

WARNING: Entanglement hazard

Do NOT operate with protective covers or guards removed. Beneath these covers are high speed moving components, which can entangle the operator or bystanders. Entanglement in this equipment may result in serious injury, amputation or death.

Check/Add Oil to the Pump

Check the oil level in the pump. Use sight glass for pump oil level. Add oil as needed.

WARNING: Burn hazard

Never open oil port while compressor is running. Hot oil can spray over face and body.

CAUTION: Inadequate lubrication hazard

Never operate compressor with inadequate lubricant. This will cause overheating and severe damage to the engine and pump.

Models 25653 and 25654 and 106694

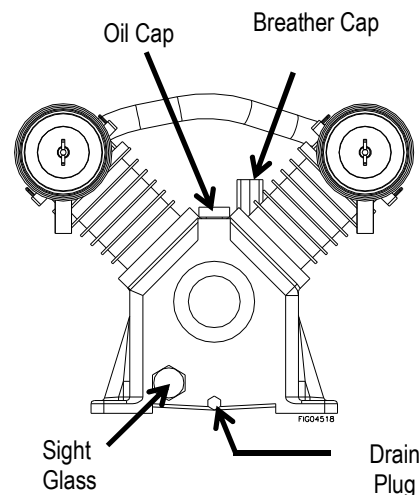

Figure 4

The Models 25653 and 25654 compressor pump capacity is 16.9 oz. Models 106694 compressor pump capacity is 33.8 oz. Use SAE 30 non-detergent pump oil (part #4043) prior to break-in. You may use synthetic lubricants after 50 hour break-in. See "Lubricants and Compatibility" for a list of suitable and alternative lubricants.

CAUTION: Synthetic lubrication damage

If you will be using a synthetic lubricant, all downstream piping material and system components must be compatible.

Start-Up Procedures

CAUTION: Break-in period

Before initial use, open the drain valve and run the compressor without air tools attached and through open air line for 30 minutes to break-in pump parts.

1. Verify that the pressure switch is in the OFF position. (Figure 5)

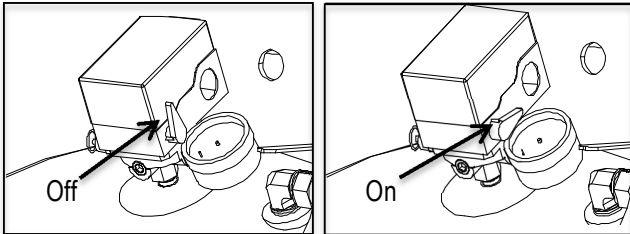

Figure 6

2. Turn regulator counter clockwise to close.
3. Verify that the pressure gauge reads zero.
4. Connect air hose to quick connect fitting.
5. Turn the pressure switch to the ON position.
6. Adjust regulator to desired pressure.
7. Allow pressure in receiver tank to build.

Note: This electric model is equipped with a pressure switch that automatically turns the motor off when the tank pressure reaches its preset level. Once air pressure in the tank drops to a preset low level, the pressure switch automatically turns the motor back on.

WARNING: Overheating

This compressor is equipped with "auto shut off". However, failure to allow adequate cooling ventilation or a restriction in the intake airflow may cause the machine to overheat.

WARNING: Inflatables/Low PSI tire

Never use compressor to inflate small low-pressure objects, i.e., balloons/inflatables, small or low volume PSI tires. It is easy to over-pressurize them, causing them to rupture. Identify the inflation capacity of an object prior to filling it with air. Use a gauge to check the pressure regularly when inflating anything.

Proper Air Hose and Tool Use

Pressure Control Related Devices

Never remove, adjust, bypass, change, modify or make substitutions for safety/relief valves, pressure switches or other pressure control related devices. Pressurizing beyond the limits of the compressor could result in an explosion.

WARNING: Overpressurization hazard

NEVER over-pressurize the receiver tank or air tools beyond nameplate capacity. Exceeding the pressure rating could cause them to explode or fly apart.

Compressor - Tool Requirements

- Compressor and attachments must be sized properly for pressure and air volume.
- Consider the maximum pressure requirements and air volume requirements of each. (The volume rating of your compressor is listed in the "Specifications" section.)

CAUTION: Tool overpressure hazard

Do not operate this unit with any tool rated less than the maximum operating pressure of the unit (135 PSI) unless a properly sized regulator limiting pressure is used before the tool.

Attaching/Disconnecting Air Hose and Tools

CAUTION: High pressure stream hazard

High-pressure air stream can pierce skin and underlying tissues, leading to serious injury and possible amputation. Such an injection injury can result in blood poisoning and/or severe tissue damage. High-pressure air stream can also cause flying debris and possible surface damage.

On a fixed line distribution system, the flexible hosing and tools would typically be connected at a terminating point. In some cases where a fixed system does not exist, the flexible hosing can be attached to the quick connect fitting on the main compressor outlet or after the user installed regulator.

CAUTION: Air tools hazard

Do not attach air tools to open end of the hose until start-up is completed and the unit checks out OK.

Quick Connect Procedure:

- Keep finger off tool or activation switch until ready to use.
- Pull quick connect collar back (Figure 7a).
- Push hose or attachment firmly against stop.
- Let go of collar (Figure 7b).
- Pull and rotate slightly (hose or attachment) to assure a tight connection.

WARNING: Projectile hazard

Air tool or attachment can become a projectile and cause serious personal injury or damage if not securely attached to the air hose.

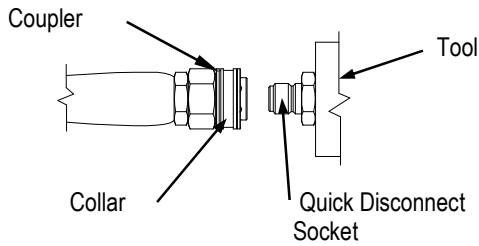

Figure 7a

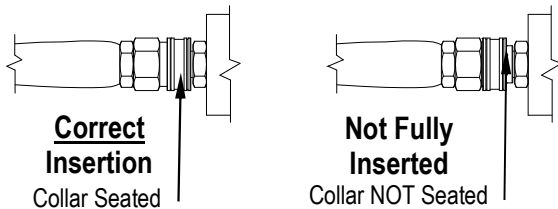

Figure 7b

Figure 7c

Using Compressor for Spraying

Flammable Materials

Always follow precautions on container labels or MSDS before spraying flammable materials, such as paint.

Moisture in Compressed Air

Moisture in supply air when compressed will form into droplets as it leaves air compressor pump and enters receiver tank. When humidity is high or when a compressor is in continuous use for an extended period of time, a significant amount of moisture will collect in the tank. Part of the moisture will be discharged in the outlet air.

When using a paint spray or sandblast gun, this water will be carried from the tank through the hose, and out of the gun as droplets mixed with the spray material. If this is not acceptable for your application, an external air dryer must be added to the system.

Shutdown

Procedure

When you are finished using the compressor:

1. Move the pressure switch to the OFF position.
2. Turn regulator counter clockwise to close.
3. Unplug the power cord.
4. Operate tools briefly to release live pressure
5. Disconnect all tools.
6. Drain air receiver tank by pulling safety relief valve.
7. After all storage air discharges, disconnect hoses.
8. Once the tank pressure gauge registers under 10 PSI, open the drain valve on the bottom of the tank to drain condensation moisture.

⚠ WARNING: Risk of bursting

Drain air receiver tank daily or after each use to prevent moisture buildup in the air tank. Serious injury or death may occur from a tank explosion caused by moisture induced tank corrosion.

For Malfunction During Operation

Immediately turn off the compressor if any of the following conditions arise during operation:

- Excessive change in motor speed, slow or fast
- Overheating
- Excessive vibration
- Unusual noise
- Flame or smoke
- Air leakage

Pull ring on safety valve to immediately relieve pressure.

⚠ WARNING: Shutdown hazards

Do not leave an operating machine unattended. Always shut the machine OFF and relieve the pressure before leaving the machine. NEVER disconnect the high-pressure outlet hose from the unit while the tank and air line are pressurized. A hazardous high pressure air stream will result as receiver tank is quickly emptied.

Maintenance & Repair

⚠ **WARNING: Maintenance hazards**

ALWAYS disconnect, lock out and tag the main power supply and then release air pressure from the receiver tank before cleaning, adjusting, or servicing the compressor. Make sure all guards and shields are replaced before re-starting.

Maintenance Schedule Summary

Item	Frequency
Inspect safety/relief valves	Weekly
Check pump oil level	Weekly
Inspect air filter	<ul style="list-style-type: none"> Weekly Replace every 12 months or 1000 hours of use
Inspect for air leaks	Monthly
Change pump oil	<ul style="list-style-type: none"> After first 50 hours of use Every 3 months or 500 hours of use
Inspect & drain receiver tank	Daily
Check drive belt tension and alignment	Monthly
Dust/debris removal	Monthly

See detailed instructions for each maintenance item below.

Detailed Instructions – Maintenance & Repair

NOTICE

Dispose of used pump oil in a manner that is compatible with the environment and in accordance with local, state, and federal laws and regulations.

- Take used oil in a sealed container to your local recycling center or service station for reclamation.
- Do not throw it in the trash, pour it on the ground, or pour it down a drain.

No Modifications. Never modify or alter the compressor in any way. Modifications can create serious safety hazards and will void the warranty.

Inspect Safety/Relief Valve

This valve should be inspected and tested on a weekly basis. The safety valve automatically releases air if the tank pressure exceeds the preset maximum.

- Check the safety/relief valve by pulling the rings. It is spring loaded and should not be stuck but come out about ¼” and then snap back into position when released.
- Replace safety/relief valves that do not operate freely with a valve of the same pressure rating.

⚠ **WARNING: Safety/Relief valve hazards**

If the safety/relief valve does not work properly, over-pressurization may occur causing air tank rupture or explosion. Occasionally pull the ring on the safety valve to make sure the safety valve operates freely. If the valve is stuck or does not operate smoothly, it must be replaced with a valve having the same pressure rating.

Inspect Air Filter

Inspect the compressor’s air filter on a weekly basis. A dirty air filter will not allow the air compressor to operate at full capacity.

- Clean air filter if dirty and restricted air flow.
- Replace the air filter every 12 months or 1000 hours.

Note: Do not operate with the air filter removed.

Inspect Compressor for Air Leaks

Inspect system for air leaks on a monthly basis. To test:

- Squirt soapy water around joints during compressor operation and watch for bubbles. Developing bubbles indicate a leak is present.
- Tighten fittings, if necessary.

Change Pump Oil

⚠ WARNING: Burn hazard

Never open oil fill port while compressor is running. Hot oil can spray over face and body.

Change oil after the first 50 hours of use then every 3 months or 500 hours; change pump oil while crankcase is still warm. (See “Appendix A: Lubricants and Compatibility” for suitable alternatives.)

Model 25653, 25654 and 106694

1. Remove the oil fill and drain plugs. Collect the oil in a suitable container.
2. Replace the oil drain plug and refill compressor crankcase with clean oil.
3. Replace the oil fill plug.
4. Start the unit and run for several minutes. Shut down the air compressor and recheck the oil level. If necessary, add more oil. (Figure 8a)

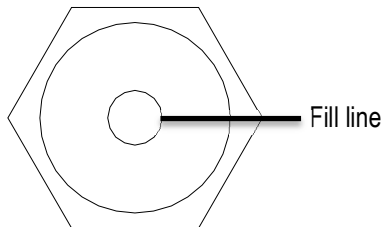

Figure 8a

Drain Receiver Tank and Inspect Tank

Drain water from the receiver tank daily. Water left in the tank can cause the tank to weaken and corrode, increasing the risk of tank rupture. Badly rusted receiver tanks must be replaced.

Northern Tool recommends a tank inspection after every 2 years of service. See “Inspection of Unfired Pressure Vessels,” volumes 2-9, August 2001, Bill McStaw (available on-line at NTIS).”

⚠ WARNING: Air tank hazards

Failure to replace a rusted air receiver tank will eventually result in tank rupture or explosion, which could cause substantial property damage, severe personal injury, or death. Never modify or repair a tank. Obtain replacement from service center.

Check Drive Belt for Tension and Alignment

⚠ CAUTION: Pulley/sheave hazard

Improper pulley/sheave alignment and belt tension can result in motor overload, excessive vibration and premature belt and/or bearing failure. To prevent this from happening, check the pulley/sheave alignment and belt tension on a regular basis.

Belts will stretch from normal use. When properly adjusted, a 5 lb. force applied to the belt between the motor pulley and the pump will deflect the belt about 1/2”.

To align and adjust drive belt tension:

1. Remove the belt guard cover.
2. Loosen the four fasteners securing the motor to the compressor unit.
3. Slide the motor to achieve proper belt tension. (Usually 1/8” to 1/4” is sufficient.) The belt must be properly aligned before refastening the motor.
4. To align belt, lay a straight edge against the face of the compressor sheave (flywheel) touching the rim at two places. (Figure 9)

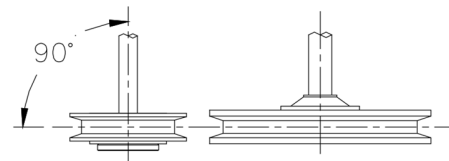
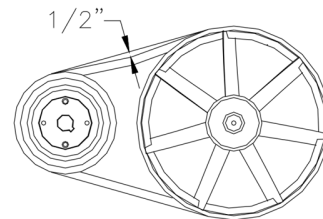

Figure 9

5. Adjust the motor pulley by shifting the motor so that the belt runs parallel to the straight edge.
6. If necessary, use a gear puller to move the motor pulley. Tighten set screw after motor pulley is positioned.
7. Check for proper belt tension. (Figure 10)



00882

Figure 10

8. Tighten the four fasteners holding the motor to the top plate while tension and alignment is maintained.
9. Attach the belt guard cover.

Keep Compressor Clean

Do not allow air intakes to become blocked. If dust or debris accumulates in the compressor, clean the compressor with a damp cloth or soft bristle brush.

Note: Do not spray compressor with a garden hose or pressure washer. Water may enter the compressor and cause damage to the engine and pump.

IMPORTANT

If a part needs replacement, only use parts that meet the manufacturer's part number specifications. Replacement parts that do not meet specifications may result in a safety hazard or poor operation of the compressor. Major service, including installation or replacement of parts, should be made by a qualified electrical service technician.

Cylinder Head Bolt Torque Specification

The recommended torque to tighten cylinder head bolts is 9~11 ft.-lbs. Bolts should be tightened according to the following sequence: 1-4-2-3-1. (Figure 11)

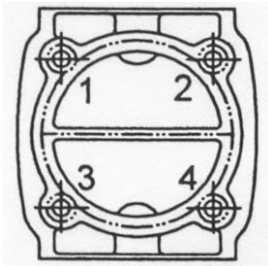

Figure 11

Contact NorthStar Product Support at 1-800-270-0810

For any questions, problems, or parts orders.

Troubleshooting

This section provides a list of the more frequently encountered compressor malfunctions, their causes and corrective actions. Some corrective actions can be performed by the operator or maintenance personnel, but others may require assistance of a qualified electrician or Service Center.

PROBLEM	POSSIBLE CAUSE
Motor does not turn.	A,B,C,D,E
Motor overload trips or draws excessive current.	D, G, M
Excessive noise, vibration, knocking or rattling.	H, I, K, L,N, O, P, R, W
Lights flicker or dim when running.	C, D, E, J, M
Air delivery drops off.	I, J, L, M, N, O, P, R, W, X, Y
Compressor does not come up to speed.	C, D, F, H, L, M, P
Compressor is slow to come up to speed.	C, D, F, H, L, M, N
Compressor will not unload cycle.	I, N, P, R
Compressor will not unload when stopped.	I, N, P, R
Excessive starting or stopping.	D, E, G, P, S, U
Moisture in crankcase, "milky" substance in oil.	T
Oil in discharge air.	V
Safety/relief valve "pops".	N, O, P
Low interstage pressure.	Y
High interstage pressure.	X

POSSIBLE CAUSE	POSSIBLE SOLUTION
A.) Circuit breaker on motor tripped.	Push button located on back of motor.
B.) Supply line circuit breaker tripped.	Reset circuit breaker.
C.) Wiring or electric service panel too small.	Install properly sized wire or service box. Contact electrician.
D.) Compressor wired incorrectly.	Check wiring, contact electrician.
E.) Poor contact on motor terminals or starter connections.	Ensure good contact on motor terminals or starter connections.
F.) Compressor viscosity too high for ambient temperature	Drain existing lubricant and refill with proper lubricant.
G) Poor ground.	Check all ground connections.
H.) Belt tension too tight or sheaves not aligned	Check tension/ alignment.
I.) Air leaks in discharge piping	Check tubing connections, Tighten joints or replace as required.
J.) Poor power regulation	Contact power company.
K.) Compressor components leaky, broken, loose	Inspect components. Clean or replace as required.
L.) Loose flywheel or motor pulley, excessive end play in motor shaft or loose drive belts	Check flywheel, motor pulley, crankshaft drive belt tension/alignment. Replace or repair as required.
M.) Leaking check valve or check valve seat blown out	Replace check valve.
N.) Clogged or dirty inlet and/or discharge line	Clean or replace.
O.) Defective safety/relief valve	Replace.
P.) Pressure switch unloader leaks or does not work	Realign stem or replace.
Q.) Inadequate ventilation around flywheel	Relocate compressor for better air flow.
R.) Leaking, broken or worn inlet unloader parts at check valve	Inspect parts and replace as required.
S.) Excessive condensation in receiver tank	Drain receiver tank.
T.) Detergent lubricant in crankcase.	Replace with proper lubricant.
U.) Light duty cycle	Increase duty cycle.
V.) Lubricant level too high	Drain excess lubricant.
W.) Worn cylinder finish	Deglaze cylinder with 180 grit flex-hone.
X,) Low pressure inlet valve leaking	Inspect, clean or repair as required.
Y.) High pressure inlet valve leaking	Inspect, clean or repair as required.

Parts Explosions – Model 25653 Rev D.7

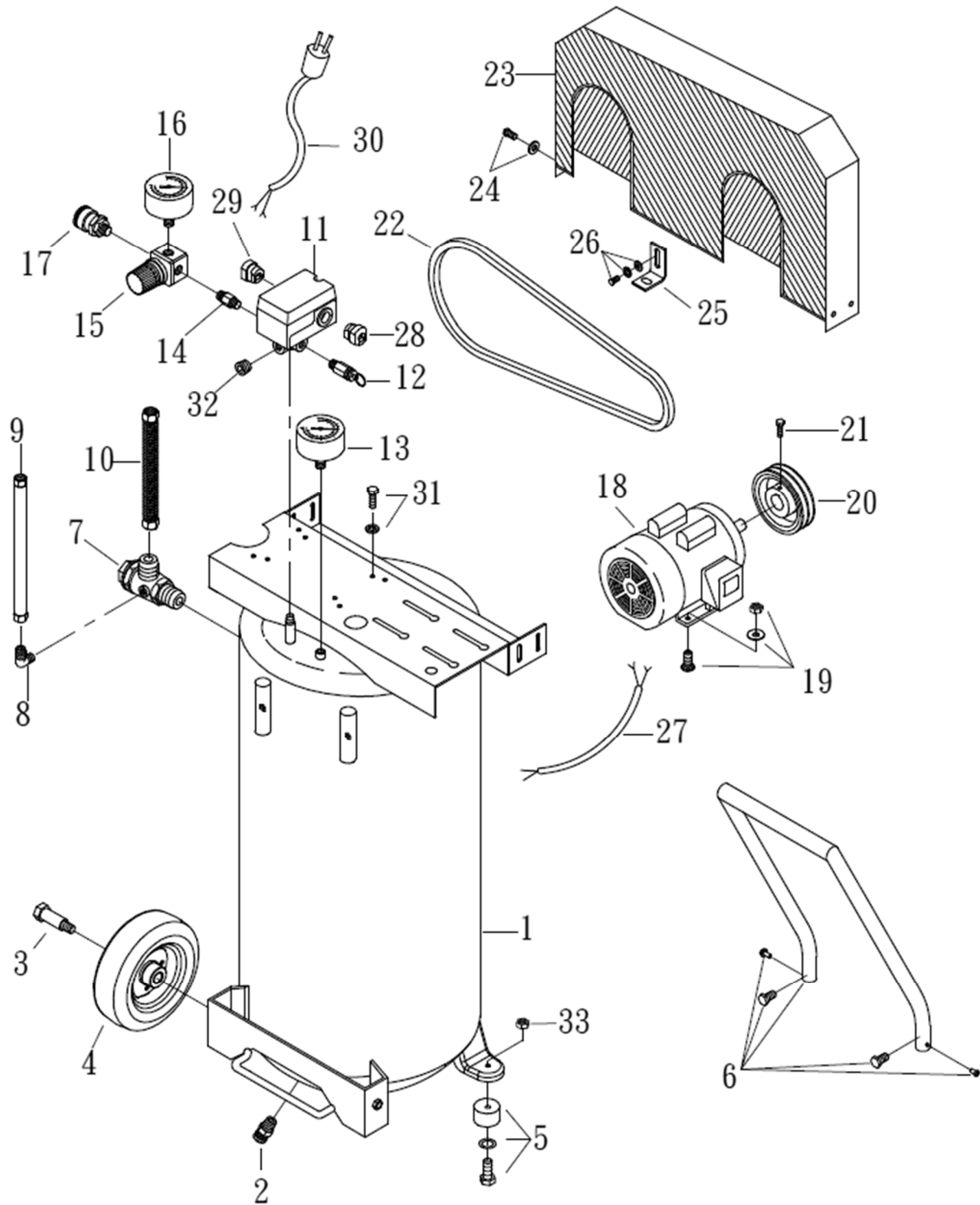

* Pump not shown on this parts explosion
Note: NorthStar tank decal part # 792438 (no shown)

Parts List – Model 25653 Rev D.7

Ref#	Part#	Description	Qty
1	N/A	Air Tank	1
2	788886	Drain Valve	1
3	Kit # 1	Tank Wheel Bolt	2
4		Tank Wheel	2
5	Kit # 2	Rubber Pad Set	2
6	788889	Grip Set	1
7	Kit # 3	Check Valve	1
8		Unloading Elbow	1
9		Unloading Tube	1
10		Exhaust Tube Set	1
11	Kit # 4	Pressure Switch	1
12		Pressure Relief Valve	1
13	788892	Pressure Gauge	1
14	Kit # 4	Nipple	1
15	Kit # 5	Regulator	1
16		Pressure Gauge	1
17		Quick Coupler	1

Ref#	Part#	Description	Qty
18	791566	Motor	1
19	788895	Motor Feet Set Bolt (4 pcs)	1
20	Kit # 6	Motor Pulley	1
21		Bolt	2
22	788897	V-Belt	1
23	Kit # 7	Belt Guard	1
24		Hexagon Bolt Set	4
25		Bracket	1
26		Hexagon Bolt Set	2
27	Kit # 8	Cable	1
28	Kit # 4,	Strain Relief Bushing	1
29	Kit # 9	Strain Relief Bushing	1
30	Kit # 8	Power Cable	1
31	N/A	Hexagon Bolt Set	4
32	Kit # 4	Plug	1
33	Kit # 2	Nut	2
*	788876	Pump Assembly	1

Kit # 1

Tank Wheel/Bolt Kit - Part # 788887

Ref#	Description	Qty	Kit Qty
3	Tank Wheel Bolt	1	2
4	Tank Wheel	1	

Kit # 2

Rubber Pad/Nut Kit - Part # 788888

Ref#	Description	Qty	Kit Qty
5	Rubber Pad Set	1	2
33	Nut	1	

Kit # 3

Check Valve /Unloading Kit - Part # 788890

Ref#	Description	Qty	Kit Qty
7	Check Valve	1	1
8	Unloading Elbow	1	
9	Unloading Tube	1	
10	Exhaust Tube Set	1	

Kit # 4

Pressure Switch/Strain Relief Kit - Part # 788891

Ref#	Description	Qty	Kit Qty
11	Pressure Switch	1	1
12	Pressure Relief Valve	1	
14	Nipple	1	
28	Strain Relief Bushing	1	
29	Strain Relief Bushing	1	
32	Plug	1	

Kit # 5

Regulator/Gauge Kit - Part # 788893

Ref#	Description	Qty	Kit Qty
15	Regulator	1	1
16	Pressure Gauge	1	
17	Quick Coupler	1	

Kit # 6

Motor Pulley/Bolt Kit - Part # 791567

Ref#	Description	Qty	Kit Qty
20	Motor Pulley	1	1
21	Bolt	2	

Kit # 7

Belt Guard/Bolt Kit - Part # 788898

Ref#	Description	Qty	Kit Qty
23	Belt Guard	1	1
24	Hexagon Bolt Set	4	
25	Bracket	1	
26	Hexagon Bolt Set	2	

Kit # 8

Cable/Power Cable Kit - Part # 788899

Ref#	Description	Qty	Kit Qty
27	Cable	1	1
30	Power Cable	1	

Kit # 9

Strain Relief Bushings Kit - Part # 788900

Ref#	Description	Qty	Kit Qty
28	Strain Relief Bushing	1	1
29	Strain Relief Bushing	1	

Parts Explosions – Model 25654 Rev D.7

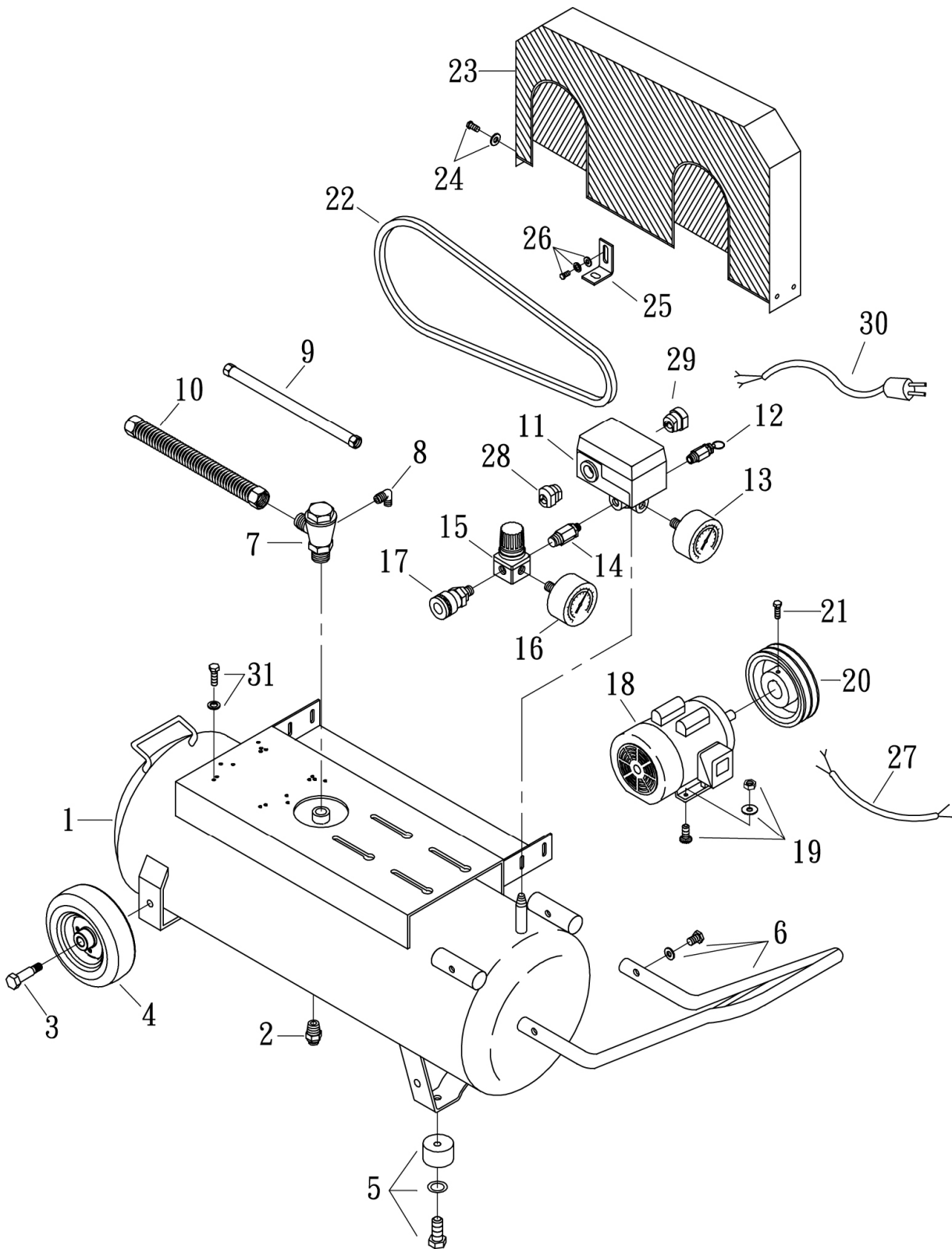

* Pump not shown on this parts explosion
 Note: NorthStar tank decal part # 792438 (no shown)

Parts List – Model 25654 Rev D.7

Ref#	Part#	Description	Qty
1	N/A	Air Tank	1
2	788886	Drain Valve	1
3	Kit # 1	Tank Wheel Bolt	2
4		Tank Wheel	2
5	Kit # 4	Rubber Pad Set	2
6	788904	Grip Set	1
7	Kit # 5	Check Valve	1
8		Unloading Elbow	1
9		Unloading Tube	1
10		Exhaust Tube Set	1
11	Kit # 6	Pressure Switch	1
12		Pressure Relief Valve	1
13	788892	Pressure Gauge	1
14	Kit # 6	Nipple	1
15	Kit # 7	Regulator	1
16		Pressure Gauge	1
17		Quick Coupler	1

Ref#	Part#	Description	Qty
18	791566	Motor	1
19	788895	Motor Feet Set Bolt (4 pcs)	1
20	Kit # 2	Motor Pulley	1
21		Bolt	2
22	788908	V-Belt	1
23	Kit # 8	Belt Guard	1
24		Hexagon Bolt Set	4
25		Bracket	1
26		Hexagon Bolt Set	2
27	Kit # 9	Cable	1
28	Kit # 3,	Strain Relief Bushing	1
29	Kit # 6	Strain Relief Bushing	1
30	Kit # 9	Power Cable	1
31	N/A	Hexagon Bolt Set	4
*	788876	Pump Assembly	1

Kit # 1

Tank Wheel/Bolt Kit - Part # 788887

Ref#	Description	Qty	Kit Qty
3	Tank Wheel Bolt	1	2
4	Tank Wheel	1	

Kit # 2

Motor Pulley/ Bolt Kit - Part # 791567

Ref#	Description	Qty	Kit Qty
20	Motor Pulley	1	1
21	Bolt	2	

Kit # 3

Strain Relief Bushings Kit - Part # 788900

Ref#	Description	Qty	Kit Qty
28	Strain Relief Bushing	1	1
29	Strain Relief Bushing	1	

Kit # 4

Rubber Pad Kit - Part # 788903

Ref#	Description	Qty	Kit Qty
5	Rubber Pad Set	1	2

Kit # 5

Check Valve /Unloading Kit - Part # 788905

Ref#	Description	Qty	Kit Qty
7	Check Valve	1	1
8	Unloading Elbow	1	
9	Unloading Tube	1	
10	Exhaust Tube Set	1	

Kit # 6

Pressure Switch/Strain Relief Kit - Part # 788906

Ref#	Description	Qty	Kit Qty
11	Pressure Switch	1	1
12	Pressure Relief Valve	1	
14	Nipple	1	
28	Strain Relief Bushing	1	
29	Strain Relief Bushing	1	

Kit # 7

Regulator/Gauge Kit - Part # 788907

Ref#	Description	Qty	Kit Qty
15	Regulator	1	1
16	Pressure Gauge	1	
17	Quick Coupler	1	

Kit # 8

Belt Guard/Bolt Kit - Part # 788909

Ref#	Description	Qty	Kit Qty
23	Belt Guard	1	1
24	Hexagon Bolt Set	4	
25	Bracket	1	
26	Hexagon Bolt Set	2	

Kit # 9

Cable/Power Cable Kit - Part # 788910

Ref#	Description	Qty	Kit Qty
27	Cable	1	1
30	Power Cable	1	

788876 Pump Explosion Rev D.7

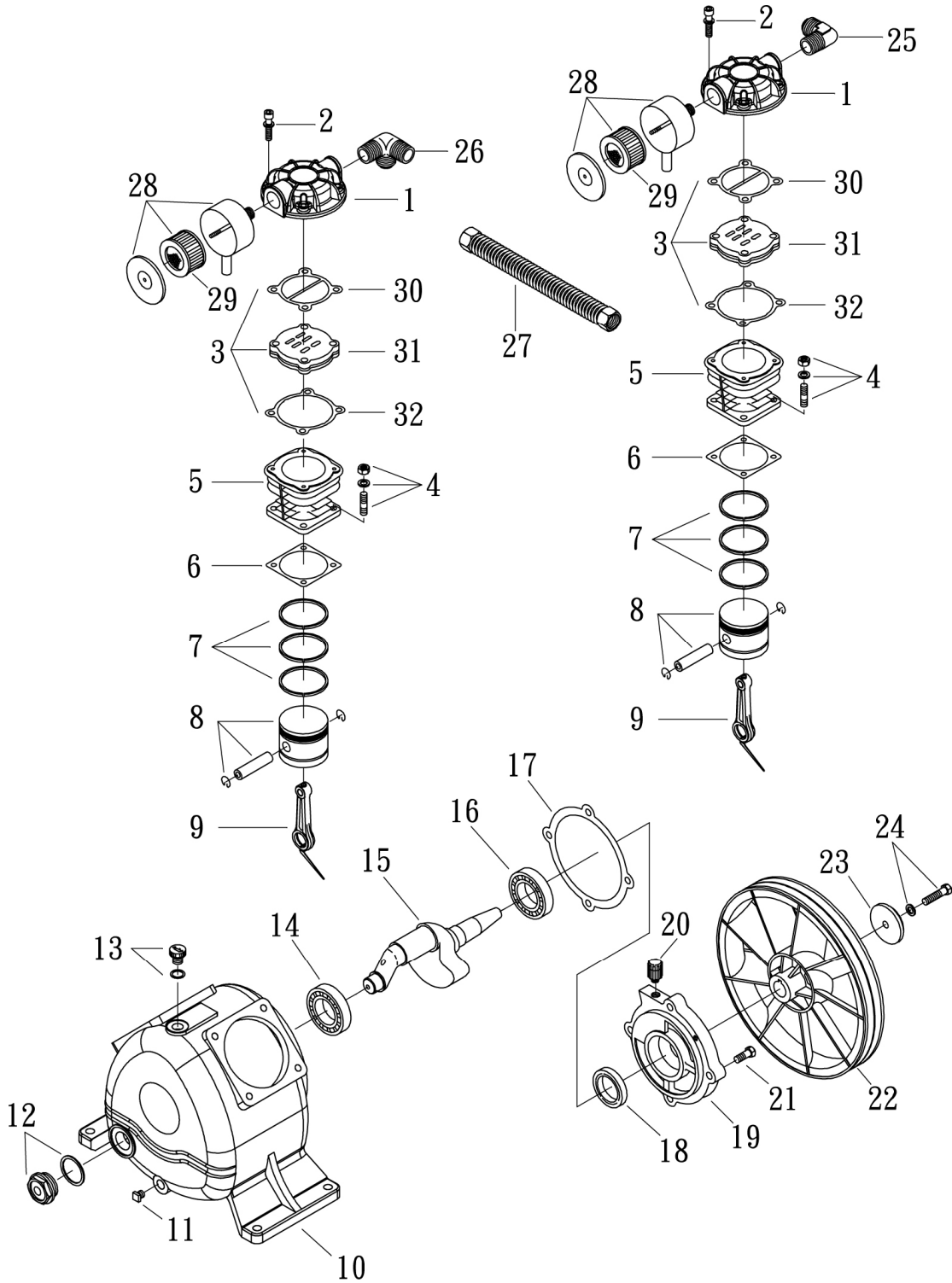

*Wing nut for # 28 not shown

788876 Pump Parts List Rev D.7

Ref#	Part#	Description	Qty	Kit #
1	788877	Cylinder head	2	N/A
2	N/A	Allen bolt set	8	N/A
3	N/A	In. & Ex. valve assembly	2	N/A
4	N/A	Double head screw set	8	N/A
5	N/A	Cylinder	2	N/A
6	N/A	Cylinder gasket	2	Kit # 1 & Kit # 2
7	N/A	Piston ring set	2	Kit # 1
8	N/A	Piston set	2	N/A
9	N/A	Rod set	2	N/A
10	N/A	Crankcase	1	N/A
11	788879	Oil draining plug	1	N/A
12	788880	Oil sight gauge set	1	N/A
13	788881	Oil filling plug set	1	N/A
14	N/A	Bearing	1	N/A
15	N/A	Crankshaft & balancer	1	N/A
16	N/A	Bearing	1	N/A
17	N/A	Rear bearing seat gasket	1	Kit # 2
18	N/A	Oil seal	1	N/A
19	N/A	Rear bearing seat	1	N/A
20	788882	Breathing cover	1	N/A
21	N/A	Hexagon bolt	4	N/A
22	N/A	Pulley	1	N/A
23	N/A	Plate washer	1	N/A
24	N/A	Hexagon bolt set	1	N/A
25	N/A	Exhaust elbow	1	N/A
26	N/A	Exhaust three way pipe	1	N/A
27	N/A	Exhaust tube set	1	N/A
28	788883	Air filter set (2 pcs)	1	N/A
29	N/A	Filter element	2	N/A
30	N/A	Cylinder gasket	2	Kit # 2 & Kit # 3
31	N/A	In. & Ex. Valve seat	2	Kit # 3
32	N/A	Valve seat gasket	2	Kit # 2 & Kit # 3
*	789523	Wing nut, air filter	2	N/A

788876 Pump Kits Rev D.7

Kit # 1 – Piston Ring Kit– Part # 788885

Ref#	Description	Qty	Kit Qty
6	Cylinder gasket	2	1
7	Piston ring set	2	

Kit # 3 – Valve Kit– Part # 788878

Ref#	Description	Qty	Kit Qty
30	Cylinder gasket	2	1
31	In. & Ex. Valve seat	2	
32	Valve seat gasket	2	

Kit # 2 – Gasket Kit– Part # 788884

Ref#	Description	Qty	Kit Qty
6	Cylinder gasket	2	1
17	Rear bearing seat gasket	1	
30	Cylinder gasket	2	
32	Valve seat gasket	2	

Parts Explosions-Model #106694

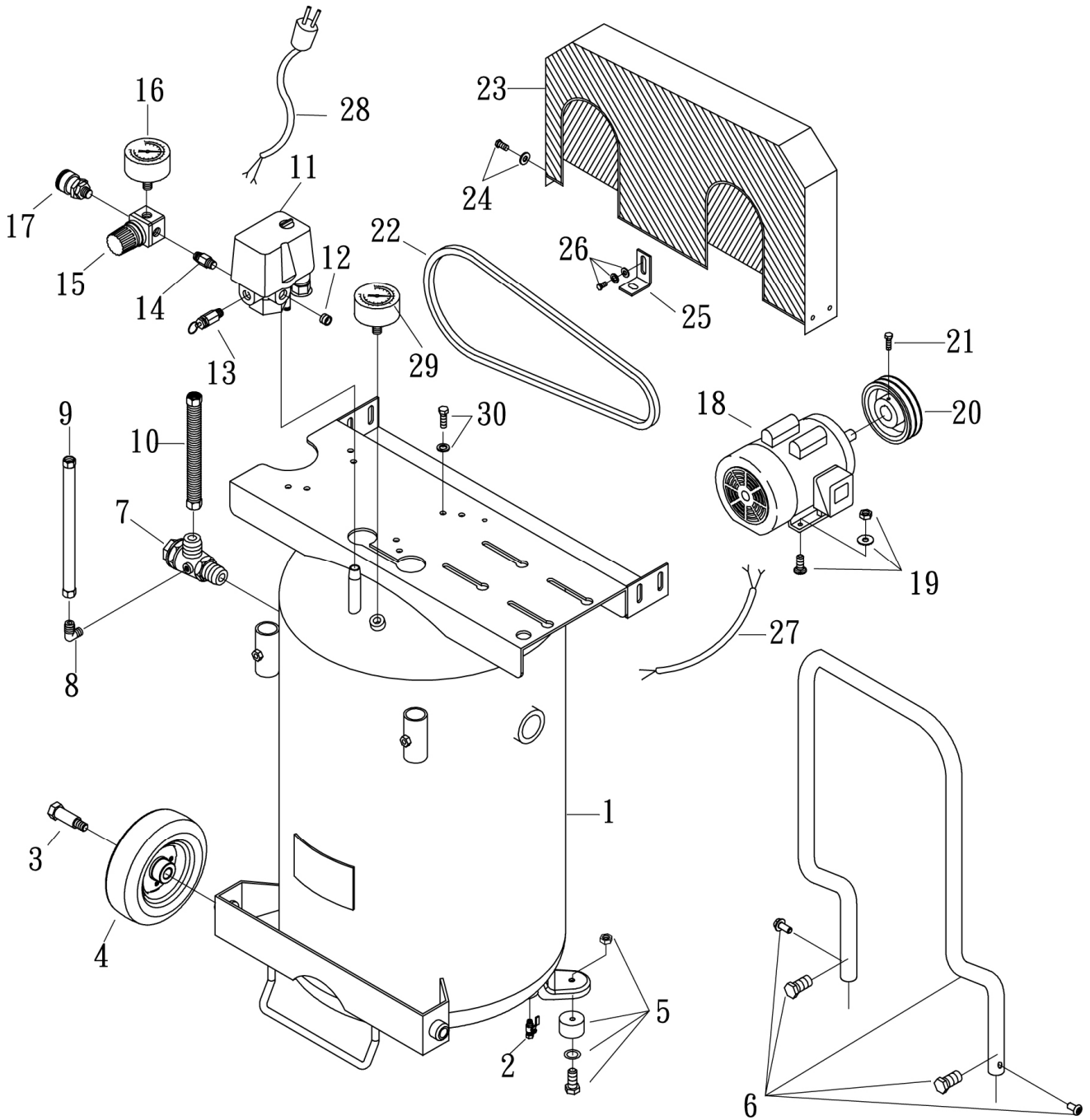

* Pump not shown on this parts explosion
 Note: NorthStar tank decal part # 792438 (not shown)

Parts List – Model #106694

Reference	Part Number	Part Description	Quantity
1	3401A245SR	Air tank	1
2	2413037	Ball valve	1
3	2418005	Tank wheel bolt	2
4	2402032B	Tank wheel	2
5	3433013-AN	Rubber pad set	2
6	3432081A-A	Grip set	1
7	2414025T	Check valve	1
8	2N06-01T02H	Unloading elbow	1
9	3B2-02*420F	Unloading tube	1
10	3B2-04*420	Exhaust tube set	1
11	2E21-BC356BEX	Pressure switch	1
12	2B14-ST02E	Plug	1
13	2406024	Pressure relief valve	1
14	2N01-02N02N045	Nipple	1
15	2408008LNX	Regulator	1
16	2D12-20D200I1	Pressure gauge	1
17	07MSO1/4M-B	Quick coupler	1
18	2M02-A7450QN	Motor	1
19	3B08-FM08*20-M	Motor feet set bolt	4
20	3PMF-032A1W0515	Motor pulley	1
21	2B07-SM08*16	Bolt	2
22	2N31-A43	V-belt	1
23	3426094	Belt guard	1
24	3B00-FM08*015W	Hexagon bolt set	4
25	3427093	Bracket	1
26	3B00-SM06*015VW	Hexagon bolt set	2
27	2E02-2030502Y2T	Cable	1
28	2E01-012W	Power cable	1
29	2D12-20D200I	Pressure gauge	1
30	3B00-FM08*025V	Hexagon bolt set	4

Parts Explosions- Pump for Model #106694

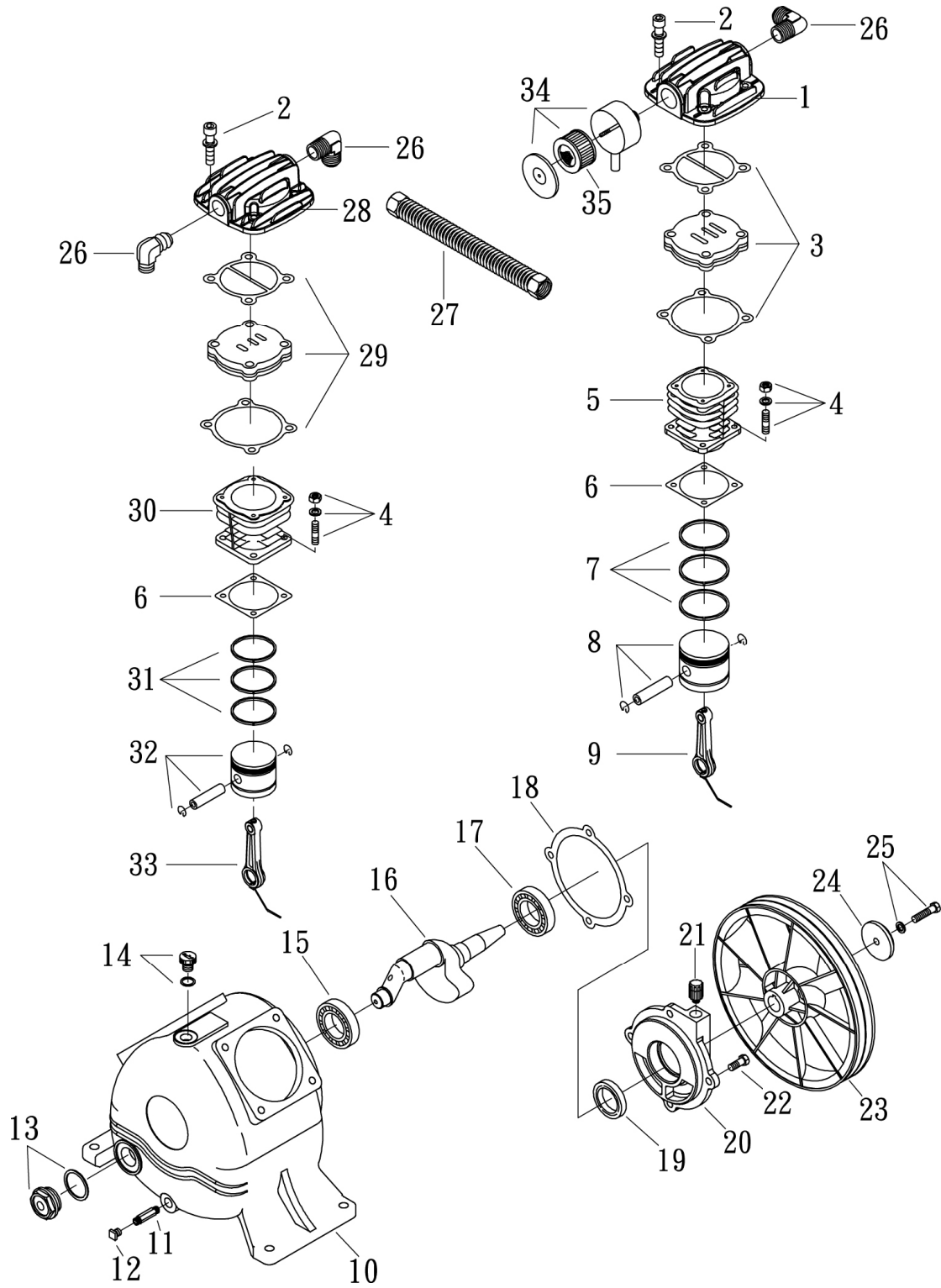

Parts List - Model #106694

Reference	Part Number	Part Description	Quantity
1	3101103	Cylinder head	1
2	3B01-M06*035V	Allen bolt set	8
3	3B13-K5070C	In. & Ex. Valve assembly	8
4	3B11-001-A	Double head screw set	1
5	3201123	Cylinder	8
6	2G04-003	Cylinder gasket	1
7	3B32-70N3	Piston ring set	2
8	3B31-70N	Piston set	1
9	3B33-H20601	Rod set	1
10	3301125	Crankcase	1
11	2305008	Oil draining tube	1
12	2N33-002	Oil draining plug	1
13	2303012A	Oil sight gauge set	1
14	2319003A	Oil filling plug set	1
15	2N35-6204	Bearing	1
16	3304038	Crankshaft & balancer	1
17	2N35-6205Z	Bearing	1
18	2G06-008	Rear bearing seat gasket	1
19	2N50-TC24*47*07	Oil seal	1
20	3311034	Rear bearing seat	1
21	2321008	Breathing cover	1
22	2B00-SM08*020	Hexagon bolt	4
23	3PBF-105A124	Pulley	1
24	2B30-08*35*35	Plate washer	1
25	3B00-SM08*035AV	Hexagon bolt set	1
26	2N06-04T04HSS	Exhaust elbow	3
27	3B2-04*520	Exhaust tube set	1
28	3101100	Cylinder head	1
29	3B13-K4251C	In. & Ex. Valve assembly	1
30	3201087	Cylinder	1
31	3B32-42N	Piston ring set	1
32	3B31-T42HN	Piston set	1
33	3B33-GT27	Rod set	1
34	2140038	Air filter set	1
35	2142021	Filter element	1

Appendix A: Lubricants and Compatibility

The following table lists materials that are suitable or not recommended for use with synthetic oil. As some oil escapes into the compressed air, all components that come into contact with the air (i.e., piping, filters, hoses, tools, etc) must be compatible with synthetic oil.

Northern Tool recommends using synthetic oil after the first 50 hour break in period.

Suitable	Not Recommended
Viton®, Teflon®, Epoxy (Glass Filled), Oil Resistant Alkyd, Fluorosilicone, Fluorocarbon, Polysulfide, 2-Component Urethane, Nylon, Delrin®, Celcon®, High Nitrile Rubber (Buna N. NBR more than 36 Acrylonite), Polyurethane, Polyethylene, Epichlorohydrin, Polyacrylate, Melamine, Polypropylene, Baked Phenolics, Epoxy, Modified Alkyds (® indicates trademark of DuPont Corporation)	Neoprene, Natural Rubber, SBR Rubber, Acrylic Paint, Lacquer, Varnish, Polystyrene, PVC, ABS, Polycarbonite, Cellulose Acetate, Latex, EPR, Acrylics, Phenoxy, Polysulfones, Styrene Acrylonitile (San), Butyl

Alternate Lubricants.

You may use a petroleum-based lubricant that is premium quality, does not contain detergents, contains only anti-rust, anti-oxidation, and anti-foam agents as additives, has a flashpoint of 440°F (227°C) or higher, and has an auto-ignition point of 650°F (343°C) or higher.

See the petroleum lubricant viscosity table below. The table is intended as a general guide only. Heavy-duty operating conditions require heavier viscosities.

Refer specific operating conditions to NorthStar Product Support at 1-800-270-0810.

Temperature around Compressor	Viscosity Grade	
	ISO	SAE
Below 40°F (4°C)	60	20
40°F to 80°F (4°C to 27°C)	100	30
80°F to 100°F (27°C to 38°C)	150	40

Limited Warranty

Dear Valued Customer:

The NorthStar Product you just purchased is built with the finest material and craftsmanship. Use this product properly and enjoy the benefits from its high performance. By purchasing a NorthStar product, you show a desire for quality and durability. Like all mechanical equipment this unit requires a due amount of care. Treat this unit like the high quality piece of machinery it is. Neglect and improper handling may impair its performance. Please thoroughly read the instructions and understand the operation before using your product. Always contact NorthStar Product Support at 1-800-270-0810 prior to having any service or warranty work performed, as some services performed by parties other than NorthStar approved service centers may void this warranty. This warranty is in lieu of any other warranty expressed or implied and NorthStar assumes no other responsibility or liability outside that expressed within this warranty.

Limited Warranty

NorthStar shall warranty any piece of equipment manufactured, or parts of equipment manufactured, to be free from defects in material or workmanship for a period of:

NorthStar Warranty		
Item #	Consumer Warranty Period	Commercial Warranty Period
25653	4 years from date of purchase by user	2 years from date of purchase by user
25654		
106694		

“Consumer use” means personal residential household use by a consumer. “Commercial use” means all other uses, including use for commercial, income producing or rental purposes or when purchased by a business.

This warranty applies to the original purchaser of the equipment (verification of purchase, in the form of a receipt, is the responsibility of the buyer), is non-transferable, and covers parts and labor. Parts will be replaced or repaired at no charge, except when the equipment has failed due to lack of proper maintenance. If a part is no longer available, the part may be replaced with a similar part of equal function. Any misuse, abuse, alteration or improper installation or operations will void warranty. Determining whether a part is to be replaced or repaired is the sole decision of NorthStar. NorthStar will not provide for replacement of complete products due to defective parts. Any costs incurred due to replacement or repair of items outside of a NorthStar approved facility is the responsibility of the buyer and not covered under warranty. Transportation costs to and from service center is the responsibility of the customer.

In addition to the normal warranty, NorthStar shall warrant any normal wear item from defects in material or workmanship for a period of 90 days from the date of purchase by user. Normal wear items include, but are not limited to, belts and filter elements.

This warranty specifically excludes the following; failure of parts due to damage caused by accident, fire, flood, windstorm, acts of God, applications not approved by NorthStar in writing, corrosion caused by chemicals, use of replacement parts which do not conform to manufacturer’s specifications, damage related to rodent and/or insect infestation and damage caused by vandalism. Additional exclusions: loss of running time, inconvenience, loss of income, or loss of use, including any implied warranty of merchantability of fitness for a specific use. Also, Power Equipment needs periodic parts and service to perform well, and this warranty does not cover instances when normal use has exhausted the life of a component or the motor.

This warranty does not cover any personal injury or damage to surrounding property caused by failure of any part. Repair or replacement of parts does not extend the warranty period.

Please fill in the following information and have it on hand when you call in on a warranty claim.

Customer Number: _____

Date of Purchase: _____

NorthStar Serial Number: _____

Item Number: _____

⚠ WARNING: This product can expose you to soots, tars, and mineral oils (untreated and mildly treated oils and used engine oils), which are known to the State of California to cause cancer.

For more information go to www.P65Warnings.ca.gov.



Distributed by:
Northern Tool & Equipment Company, Inc.
Burnsville, MN 55306
www.northerntool.com
Made in Taiwan