

MODEL # 2150

ASSEMBLY INSTRUCTIONS



Visit our EarthWay website to see the assembly video



Prior to assembly, you will need:

Needle nose pliers

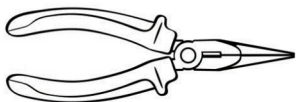

#2 Phillips screwdriver

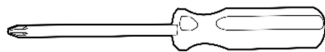

Two 7/16" adjustable or box wrenches

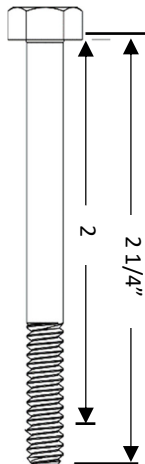
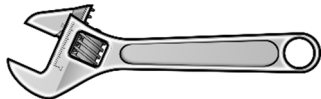

SIDE SPREAD CONTROL

SIDESPREAD CONTROL™

Your EarthWay spreader includes a patented feature to prevent fertilizer from being spread to the left side. To activate this feature, slide the lever below the hopper to the back (if standing behind the spreader) and position the left wheel 6"-12" from your sidewalk or border. This will not waste fertilizer like competitor designs that leave 7X the fertilizer inside the wheels from blocking material leaving the impeller.

ASSEMBLY HARDWARE

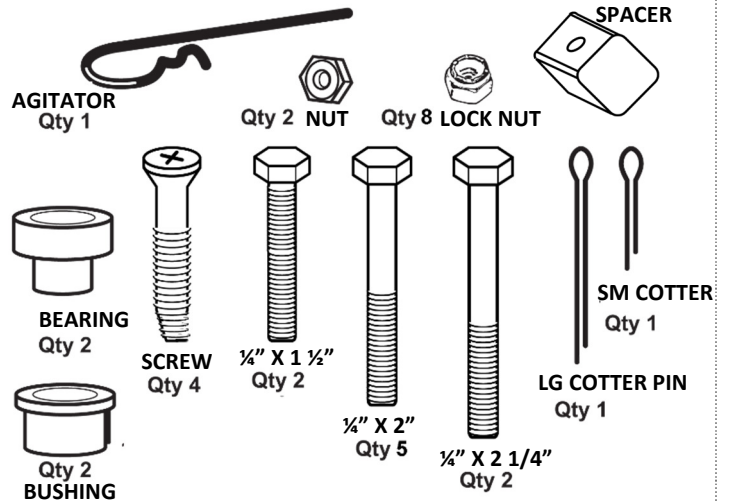

SPREADER COMPONENTS

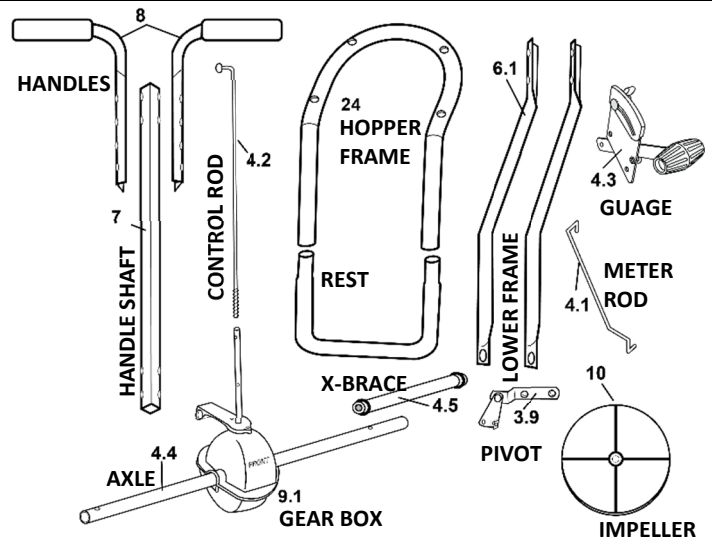

SPREADER RATE SETTINGS

LBS PER 1000 SQUARE FEET	GRASS SEED	FERTILIZER SGN 240 (3/32")	SAND SGN 150 (1/16")
1 LB		9	7
2 LB	14	13	10
3 LB	16	16	13
4 LB	18	20	14
5 LB	20	22	16
8 LB		28	22

HELPFUL HINTS

- ☑ Read the directions before assembly.
- ☑ If your spreader does not spread evenly, be sure “FRONT” on the GEARBOX points to the front of the spreader. **The impeller must turn clockwise when pushing forward.** Reversing the GEARBOX during assembly will cause issues.
- ☑ Your spreader is calibrated for three miles per hour, which is a brisk walking speed. Slower or faster speeds will change the spread pattern. Wet fertilizer will also change the spread pattern and flow rate. **Do not use powdered materials as it will damage the gearbox.**
- ☑ Gears are permanently lubricated at the factory. Do not open the GEARBOX or dirt may enter.

IF YOUR SPREADER COMES SEMI ASSEMBLED, SKIP TO STEP #7

SPREADER ASSEMBLY INSTRUCTIONS

Step 1: Remove all components and hardware items from the box. Place the spreader hopper upside down and facing away from yourself.

Step 2: Install FRAME using (4) #14 x 1½” Flat Head Phillips screws. **TIGHTEN THESE NOW**

Step 3: Install impeller onto pinion shaft by pressing the impeller as shown onto the pinion shaft and turning the impeller while holding the pinion shaft to engage with the **COIN** fully, and press down to secure.

Next, insert Cross Brace thru the Gearbox Brace as shown above.

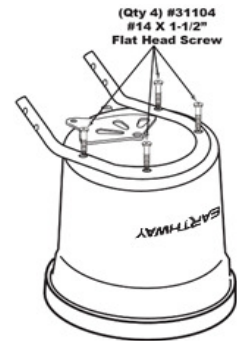

GEARBOX ASSEMBLY

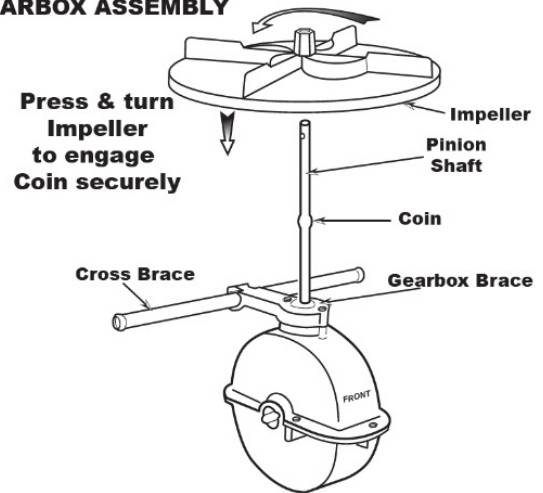

Step 4: Install GEARBOX by inserting the PINION SHAFT into hole in center of HOPPER bottom. The word "FRONT" on the GEARBOX must point to Front of the HOPPER.

NOTE: Place EarthWay brand towards the front of the hopper.

Step 5: (A) Install LOWER HANDLES onto FRAME to both sides as shown. Insert 2¼" bolt through hole in LOWER HANDLE and through hole in FRAME install locknut. **DO NOT TIGHTEN.**

(B) Now insert 1½" bolt into the hole in LOWER HANDLE, then through FRAME brace. Next into threaded connector in CROSS BRACE. **DO NOT TIGHTEN**

NOTE: Numbers on frame brace must be facing toward gear box as shown.

(C) Install the FOOT into the FRAME and align the bolt holes in the FOOT and the FRAME (a Phillips screwdriver or large nail is helpful to align the parts)

(D) Next insert 1½" bolt through other end of FRAME BRACE and through hole in FRAME through the FOOT and install locknut.

Step 6: Slide AXLE into the LOWER HANDLE, then the GEARBOX and into the other LOWER HANDLE as shown above. Next, install AXLE BEARINGS over the AXLE and into both LOWER HANDLES as shown above.

NOTE: Tab on BEARINGS and notches in the LOWER HANDLES you need to align.

Now slide the BUSHINGS over the AXLE (as shown above) and into the BEARINGS.

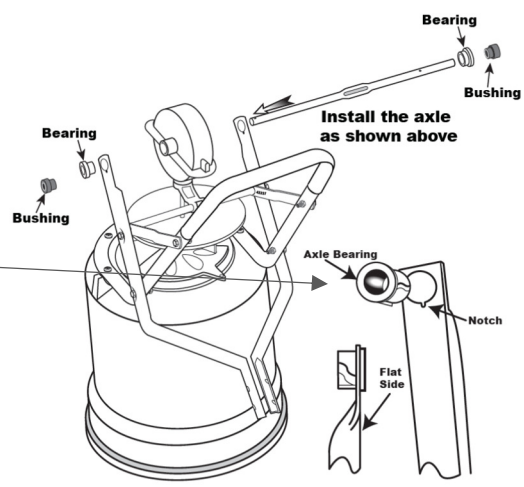
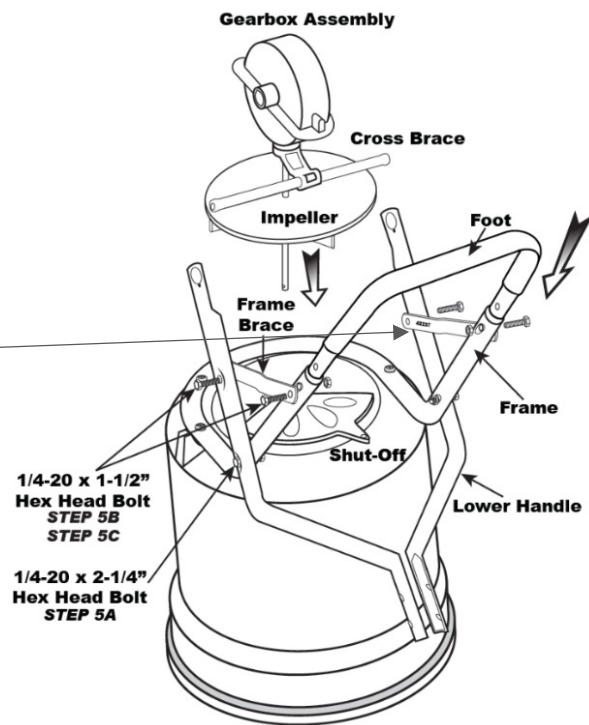
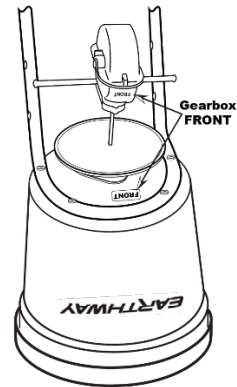

NOW GO BACK AND TIGHTEN ALL NUTS AND BOLTS STARTING WITH FIRST STEP. DO NOT OVER TIGHTEN.

Step 7: Install DRIVE WHEEL onto the AXLE and align with the cotter pin hole nearest to LOWER HANDLE as shown. Insert 2" cotter pin through wheel and through AXLE. Bend with pliers to prevent pin from falling out.

Step 8: Install COAST WHEEL onto the AXLE fully, then using outside cotter pin hole, insert 1" cotter pin through AXLE (not thru the wheel). Bend with pliers to prevent pin from falling out.

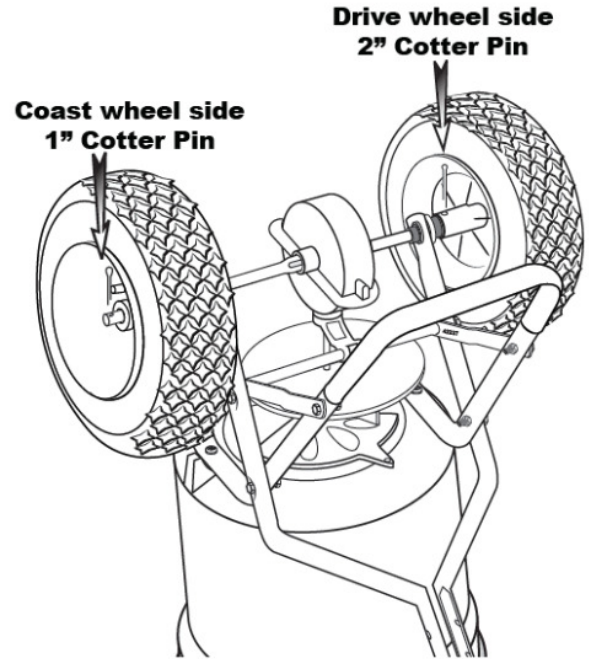

TURN SPREADER UPRIGHT ON TO WHEELS

Step 9: New for 2021 EarthWay listened to customers who desired an adjustable handle for taller operators.

Select three 1/4" x 2" bolts and three nylon lock nut to complete this step.

Notice that the square handle shaft has two sets of holes in both ends. The end that the holes are closest to the end of the handle shaft is the top. Place it as shown inbetween the handles.

Start by bolting through the handle spacer using the top most handle bar hole. Then bolt the gauge & lever assembly through the two center holes using two of your 1/4" x 2" bolts.

TIGHTEN ALL HARDWARE.

TALL OPERATOR CONFIGURATION – with the four handle holes, use the bottom two holes for the gauge and use the top hole for the spacer.

See the video for an example.

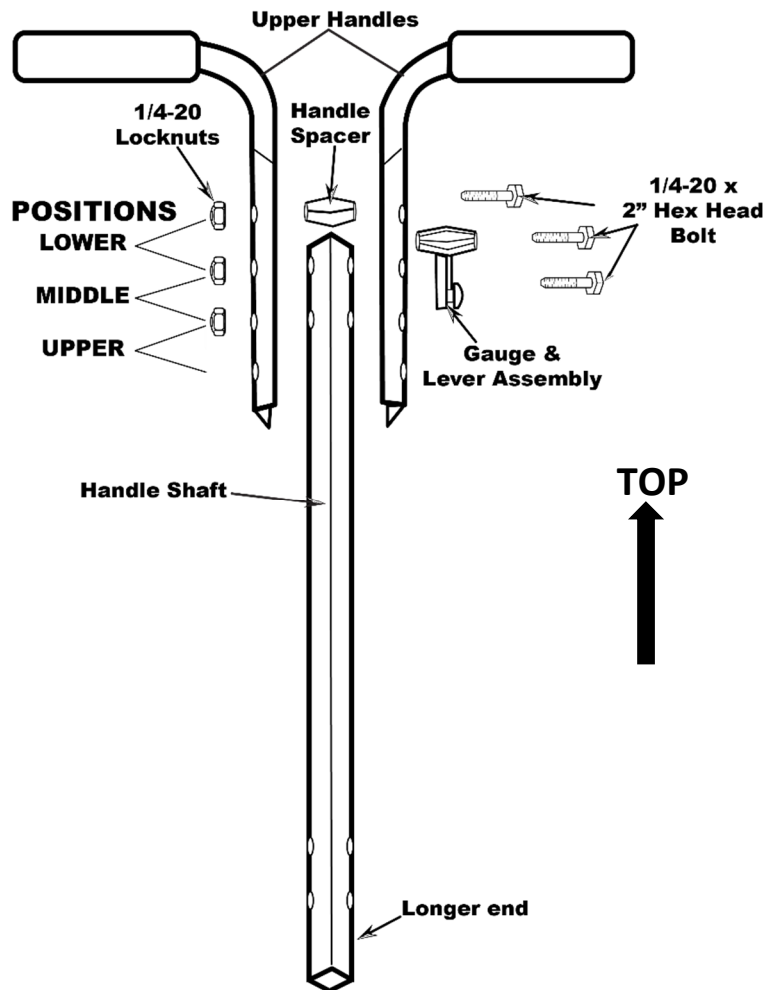

Step 10: Take the shortest end of the PIVOT ROD and insert into the SHUT-OFF PLATE. You may have two holes, use the SHUT-OFF PLATE hole towards the back of the spreader. Insert it through the hole (downward) and then rotate 90 degrees so that end is turned parallel as shown.

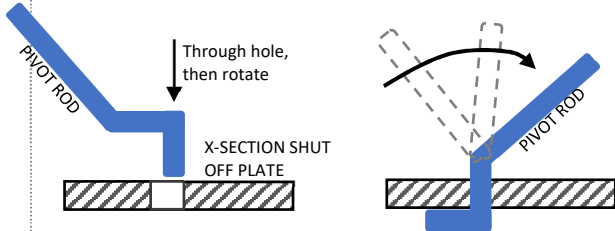

Step 11: Locate the PIVOT ROD basket, insert the other end of the PIVOT ROD through the back of the PIVOT ROD BRACKET as shown (see below).

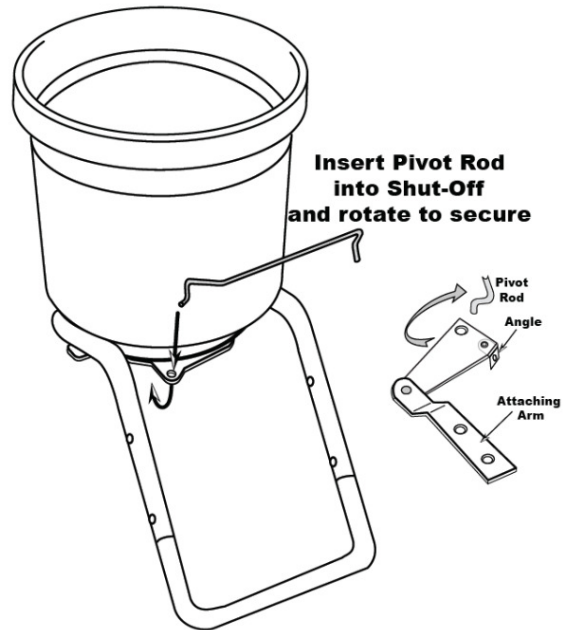

Step 12: Install HANDLE SHAFT to LOWER HANDLES and PIVOT & BRACKET assembly as shown. Using 2" bolts and locknuts. **TIGHTEN BOLTS AND NUTS NOW.**

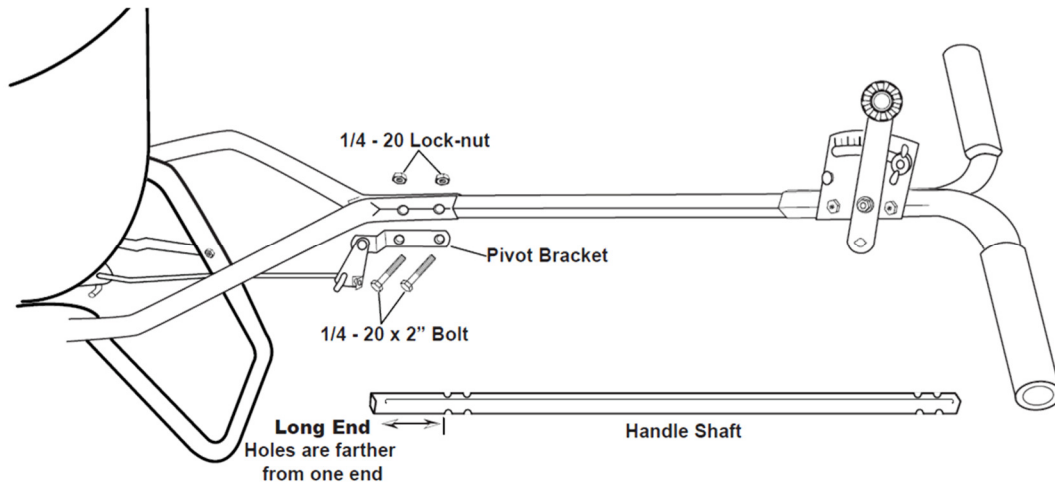

Step 13: Install flattened end of CONTROL ROD in to LEVER on GAUGE as shown. Turn to lock in place. Next push LEVER forward to setting "0". Align CONTROL ROD with hole in PIVOT BRACKET, pull LEVER backward to insert CONTROL ROD through hole in PIVOT BRACKET.

Step 14: Install (1) 1/4-20 regular nut (not a locknut) on to CONTROL ROD as shown.

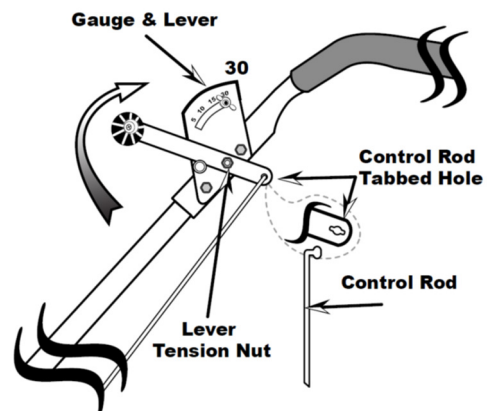

CALIBRATION

Step 15: Pull lever back to setting “30” as shown. Next push pivot & bracket forward so that the shut off plate in the hopper is in the full open position. **REMEMBER SETTING “30” ON THE FLOW CONTROL LEVER MUST PLACE THE SHUT-OFF PLATE IN THE FULL OPEN POSITION TO BE PROPERLY CALIBRATED.** Now tighten the nuts against the PIVOT BRACKET to prevent change in calibration.

NOTE: Tension on the flow control lever may be adjusted by tightening or loosening the tension nut as shown.

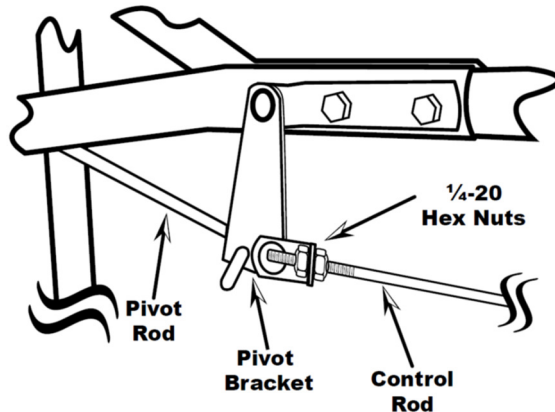

Step 16: Insert agitator to pinion shaft on inside of hopper.

Note: the position of flat side of the agitator. This pin should be installed as shown.

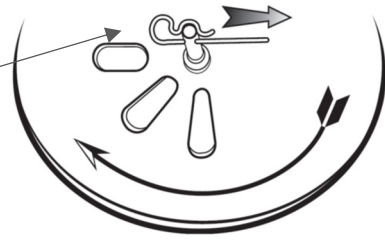

SPREADER CALIBRATION INSTRUCTIONS

Professional turf managers only purchase spreaders that can be calibrated. National brand spreaders cannot be calibrated and thus provide poor results. To achieve optimal accuracy, we recommend you check your calibration every other year.

Open the spreader gauge to #30, inside the hopper, move control plate to the full open.

1. Open the shut-off so that the drop holes are completely open as illustrated to the right.
2. Review the Control Lever position—if it is set so that the forward edge is at #30, you are calibrated. If not, you need to adjust the control rod at the pivot bracket shown
 - A. If your shut-off is not able to open fully as in step #1. Loosen the top nut a few turns, then loosen the lower nut so that it allows you to push the shut-off open fully. Next tighten each nut so that they contact the pivot bracket without moving it, and then carefully tighten each nut fully so they do not loosen during use. Recheck adjustment as outlined in #1 above.
 - B. If your shut-off is able to open fully as in step #1, but the Control Lever is not at #30. Loosen the top nut a few turns, then loosen the lower nut so that it allows you to push the Control Lever to #30. Next tighten each nut so that they contact the pivot bracket without moving it. Carefully tighten each nut fully so they do not loosen during use. Recheck adjust as outlined in #1 above.

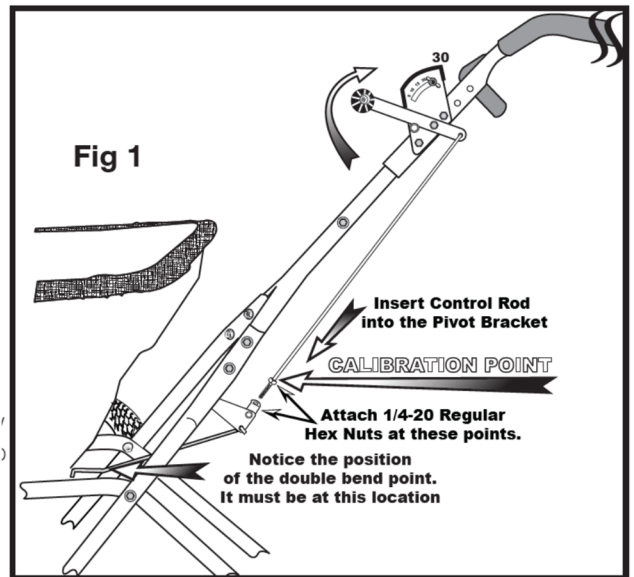

OPERATING INSTRUCTIONS

- ☑ Obtain proper setting for material to be used from the enclosed SETTING MATRIX included with this spreader, or from our web site under the MANUALS SECTION.
- ☑ Set stop bolt on rate gauge assembly to the proper rate setting.
- ☑ While pushing spreader forward, pull control lever back to stop bolt, to stop spreading, push lever forward to close flow holes before you stop moving.
- ☑ When finished, empty any remaining material from hopper, rinse spreader, apply coating of light oil to all metal parts. The gearbox is sealed and is factory lubricated.

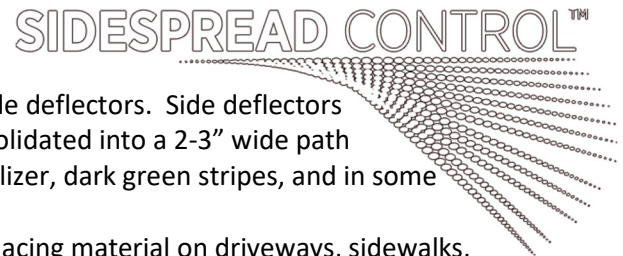

The **SideSpread-Control** is a patented innovation that is superior to side deflectors. Side deflectors block material leaving the impeller. This blocked material is now consolidated into a 2-3" wide path on the left inside wheel of your spreader. This equates to wasted fertilizer, dark green stripes, and in some cases this extra fertilizer (seven times) will damage the lawn.

SideSpread-Control maintains the correct application rate while not placing material on driveways, sidewalks, flowerbeds, or worse, the storm drains in your street. This saves you money and keeps you from damaging your lawn.

To engage **SideSpread-Control**:

- 1) Locate the lever on under the right side of the hopper.
- 2) Slide the control lever from the front to the back.
- 3) Position the left wheel of your spreader 6"-12" from the sidewalk, flowerbed, or driveway and spread as normal.
- 4) When you have completed this spreading pass, close the control lever to "0", and then open the **SideSpread-Control™** by sliding the control lever from back to the front, for a **FULL**, 180 degree spread pattern.

CUSTOMER SERVICE

SUPPORT@EARTHWAY.COM | www.EARTHWAY.com | 1009 Maple Street, Bristol, IN 46507

ONE YEAR WARRANTY

EarthWay Products, Inc. warrants this product free of defects in original workmanship and materials for a period of one year to the end user with the original purchase receipt. If a manufacturing non-conformance is found, EarthWay Products, Inc. at its discretion will repair or replace the part(s)/product at no charge provided the failure is not the result of incorrect installation, mishandling, misuse, tampering, or normal wear and tear as determined by EarthWay.

EarthWay at its discretion may require that the part(s) or product be returned along with the original purchase receipt for examination and compliance with the terms of this warranty. Do not return any product without first receiving authorization from EarthWay Products, Inc.

To seek remedy under this warranty, contact EarthWay Products, Inc. at support@earthway.com or write to EarthWay Products, Inc. 1009 Maple Street, Bristol, IN 46507 and describe the nature of the manufacturing defect. **SPECIFIC LIMITATIONS:** This warranty covers only the part(s) or product; any labor charges associated with repair or replacement of non-conformances are specifically excluded. Due to the corrosive nature of most fertilizers and ice melt products, EarthWay Products, Inc. makes no warranty against and specifically excludes part(s) or product degradation or failure due to corrosion or its effects.

HOW TO ORDER SPARE PARTS – CALL or EMAIL:
TURF DEPOT 800-305-9255 or earthway@turfdepot.com

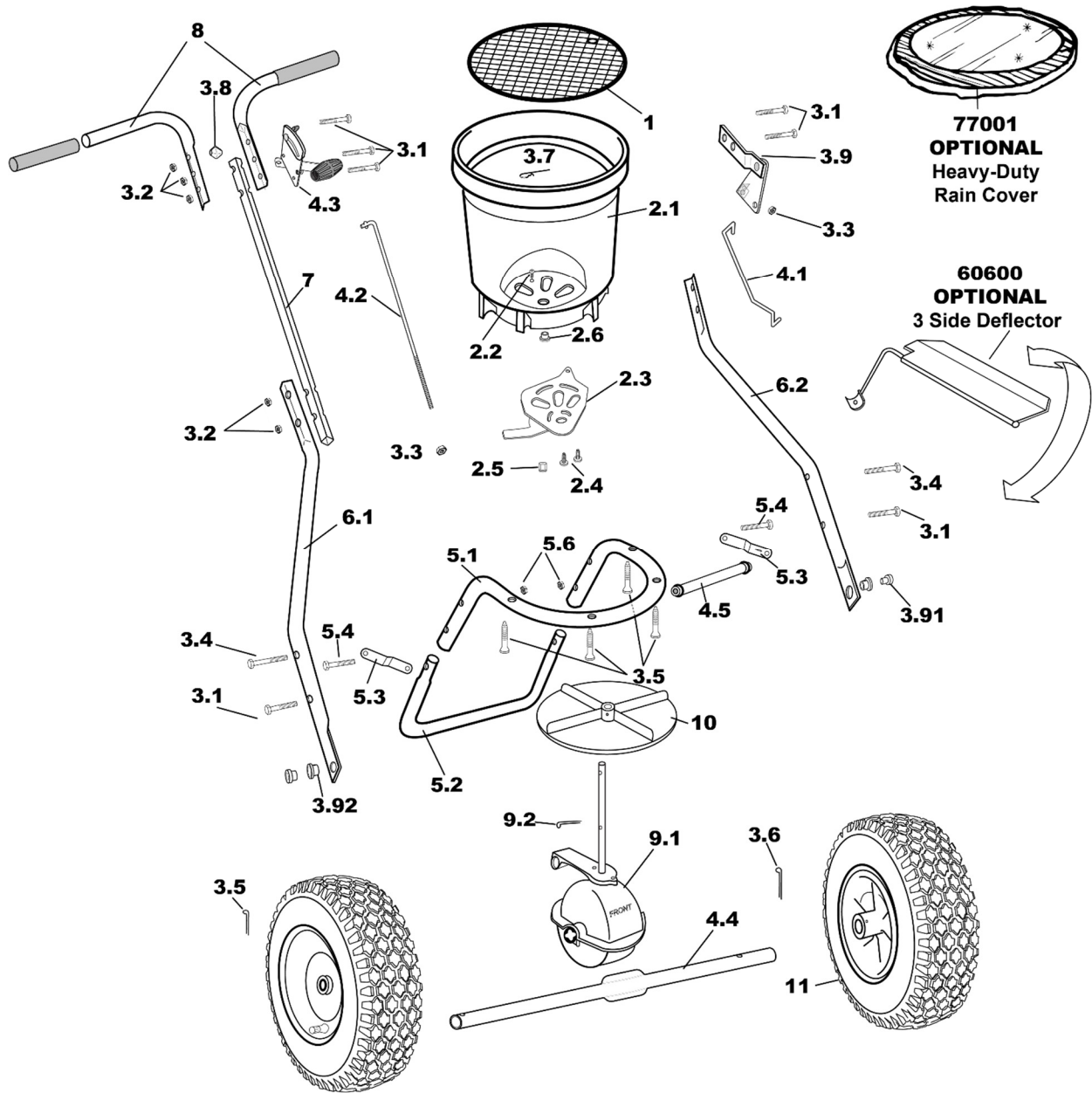

50# (2150) Broadcast Spreader Parts List					
SERIES	PART #	DESCRIPTION	SERIES	PART #	DESCRIPTION
1	40002	ROUND SCREEN	8	60602	OPERATOR HANDLES
2	60332	HOPPER ASSEMBLY KIT (2.1 – 2.6)	9	60333	GEARBOX & IMPELLER SHAFT KIT (9.1-9.2)
3	38168	HARDWARE KIT (3.1 - 3.92)	10	12110	IMPELLER
4	60260	CONTROL KIT & X-BRACE KIT (4.1- 4.5)	11	70138	13" PNEUMATIC TIRE
5	60603	LOWER FRAME ASSY KIT (5.1 – 5.6)	12	60298	GAUGE & LEVER ASSEMBLY
6	25222	HANDLE TO FRAME AXLE ARMS (6.1 & 6.2)	13	60175	UPPER HANDLE SQUARE W/GRIP
7	25223	HANDLE SHAFT - SQUARE		77001	HEAVY DUTY RAIN COVER ACCESSORY
				60600	THREE SIDE DEFLECTOR KIT