

12" Deluxe Woodworking Bandsaw

Model: 10-315

RIKON
POWER TOOLS



Record the serial number and date of purchase
in your manual for future reference.

Serial number: _____

Date of purchase: _____

For more information:

www.rikontools.com or info@rikontools.com

For Parts or Questions:

techsupport@rikontools.com or 877-884-5167









Operator Safety: Required Reading

IMPORTANT! Safety is the single most important consideration in the operation of this equipment. **The following instructions must be followed at all times.**

There are certain applications for which this tool was designed. We strongly recommend that this tool not be modified and/or used for any other application other than that for which it was designed. If you have any questions about its application, do not use the tool until you have contacted us and we have advised you.

General Safety Warnings

KNOW YOUR POWER TOOL. Read the owner's manual carefully. Learn the tool's applications, work capabilities, and its specific potential hazards.

 ⚠ DANGER	ALWAYS GROUND ALL TOOLS. If your tool is equipped with a three-pronged plug, you must plug it into a three-hole electric receptacle. If you use an adapter to accommodate a two-pronged receptacle, you must attach the adapter plug to a known ground. Never remove the third prong of the plug. ALWAYS AVOID DANGEROUS ENVIRONMENTS. Never use power tools in damp or wet locations. Keep your work area well lighted and clear of clutter.
 ⚠ DANGER	ALWAYS REMOVE THE ADJUSTING KEYS AND WRENCHES FROM TOOLS AFTER USE. Form the habit of checking to see that keys and adjusting wrenches are removed from the tool before turning it on. ALWAYS KEEP YOUR WORK AREA CLEAN. Cluttered areas and benches invite accidents.
 ⚠ DANGER	ALWAYS KEEP VISITORS AWAY FROM RUNNING MACHINES. All visitors should be kept a safe distance from the work area. ALWAYS MAKE THE WORKSHOP CHILDPROOF. Childproof with padlocks, master switches, or by removing starter keys.
 ⚠ DANGER	NEVER OPERATE A TOOL WHILE UNDER THE INFLUENCE OF DRUGS, MEDICATION, OR ALCOHOL.
 ⚠ DANGER	ALWAYS WEAR PROPER APPAREL. Never wear loose clothing or jewelry that might get caught in moving parts. Rubber-soled footwear is recommended for the best footing.
 ⚠ DANGER	ALWAYS USE SAFETY GLASSES AND WEAR HEARING PROTECTION. Also use a face or dust mask if the cutting operation is dusty.
 ⚠ DANGER	NEVER OVERREACH. Keep your proper footing and balance at all times.
 ⚠ DANGER	NEVER STAND ON TOOLS. Serious injury could occur if the tool is tipped or if the cutting tool is accidentally contacted.

▲ DANGER**ALWAYS DISCONNECT TOOLS.**

Disconnect tools before servicing and when changing accessories such as blades, bits, and cutters.

**ALWAYS AVOID ACCIDENTAL STARTING.**

Make sure switch is in "OFF" position before plugging in cord.

NEVER LEAVE TOOLS RUNNING UNATTENDED.**▲ DANGER****ALWAYS CHECK FOR DAMAGED PARTS.**

Before initial or continual use of the tool, a guard or other part that is damaged should be checked to assure that it will operate properly and perform its intended function. Check for alignment of moving parts, binding of moving parts, breakage of parts, mounting, and any other conditions that may affect its operation. A guard or other damaged parts should immediately be properly repaired or replaced.



Special Safety Rules For Bandsaws

1. Always allow the Bandsaw blade to stop before removing scrap pieces from table.
2. Always keep hands and fingers away from the blade.
3. Never attempt to saw stock that does not have a flat surface, unless a suitable support is used.
4. Always hold material firmly and feed it into the blade at a moderate speed.
5. Always turn off the machine if the material is to be backed out of an uncompleted cut.
6. Adjust the upper guide about 1/8" above the material being cut.
7. Check for proper blade size and type for thickness and material being cut.
8. Make sure that the blade tension and blade tracking are properly adjusted.
9. Make "relief" cuts before cutting long curves.
10. Release blade tension when the saw will not be used for a long period of time.

California Proposition 65 Warning

WARNING: Some dust created by power sanding, sawing, grinding, drilling, and other construction activities contains chemicals known to the State of California to cause cancer and birth defects or other reproductive harm. Your risk from exposure to these chemicals varies, depending on how often you do this type of work. To reduce your exposure, work in a well-ventilated area and with approved safety equipment, such as dust masks that are specially designed to filter out microscopic particles.

For more detailed information about California Proposition 65 log onto rikontools.com.

SAVE THESE INSTRUCTIONS.
Refer to them often.

Table of Contents

Safety Warnings.....	2-3
Bandsaw Safety Rules	3
Specifications	4
Contents of Package	5-6
Getting To Know Your Bandsaw	7
Stand Assembly	8
Assembly	9
Assembly the Working Table.....	9
Rip Fence Assembly	9
Installing the Tool Holder.....	10
Hand-Wheel Assembly	10
Setting the Table Square to the Blade.....	10
Tilting the Table	11
Tracking the Saw Blade	11
Adjusting Blade Tension	11
Upper Blade Guide Adjustment	11-12
Lower Blade Guide Adjustment	12
Adjusting the Rip Fence/Drift.....	12-13
Rip Fence Scale Adjustment	13
Cutting Height Adjustment	13
Changing Blade Speed/Belt Tension.....	14
Replacing Blades	14-15
Resawing	15
Operation	15
Maintenance	16
Wiring Diagram	16
Troubleshooting	17-18
Changing Bandsaw Tire	18
Parts Diagram	19-21
Parts List	22-23
How To Guide	24
Warranty	25
Notes.....	26-27

Specifications

Throat width	12"
Max. cutting depth	7"
Blade length	93-1/2"
Blade width	1/8" – 3/4"
Table size	18-7/8" x 15-3/4"
Table tilt	Left-10° Right-45°
Blade speeds	1496 ft/min or 3230 ft/min
Motor	1 HP
Amps	10/5
Volts	110/220
Net weight	176 lbs

Contents of Package

Model 10-315 12" Deluxe Woodworking Bandsaw is shipped complete in one box.

1. Unpacking and Checking Contents

- Separate all "loose parts" from packaging materials, the following components are included for the initial assemble and make sure all items are accounted for, before discarding any packaging material.
- With the help of another person, take the Bandsaw from the packing carton. Properly lift the Bandsaw off the packing carton and place on level floor.
- Remove protective oil that is applied to the table. Use any ordinary house hold type grease or spot remover.
- Apply a coat of paste wax to the table to prevent rust. Wipe all parts thoroughly with a clean dry cloth.

A. Bandsaw Body

B. Cabinet Stand Box

C. Crank Handwheel

D. Blade Tension Wheel

E. Manual

A



B

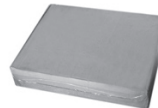

C



D



E

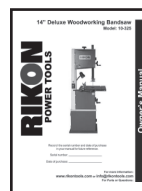

Contents of Package Cont.

Table assembly:

- A. Table
- B. Table leveling bar and hardware
- C. 90° table stop bolt
- D. Table mounting bolts and washers

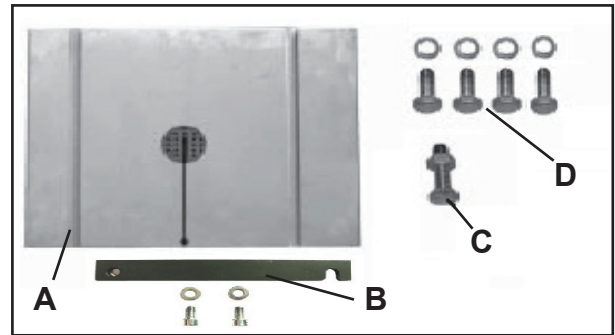

Rip fence assembly:

- A. Scale
- B. Fence bar
- C. Fence
- D. Resaw bar
- E. Fence carrier
- F. Fence support on left side of the table
- G. Lock shoe

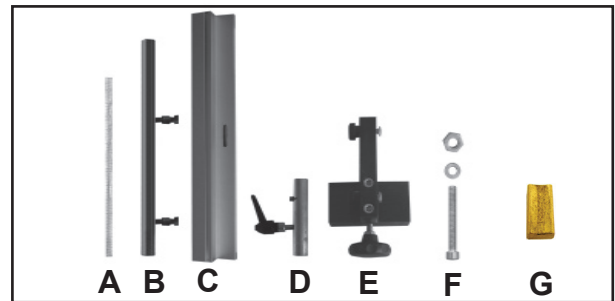

Tool holder assembly:

- A. L wrench 3MM
- B. L wrench 4MM
- C. L wrench 5MM
- D. L wrench 6MM
- E. Tool holder
- F. Tool Holder mounting screws

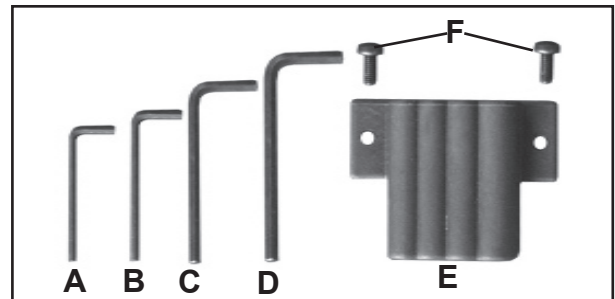

Getting to Know Your Bandsaw

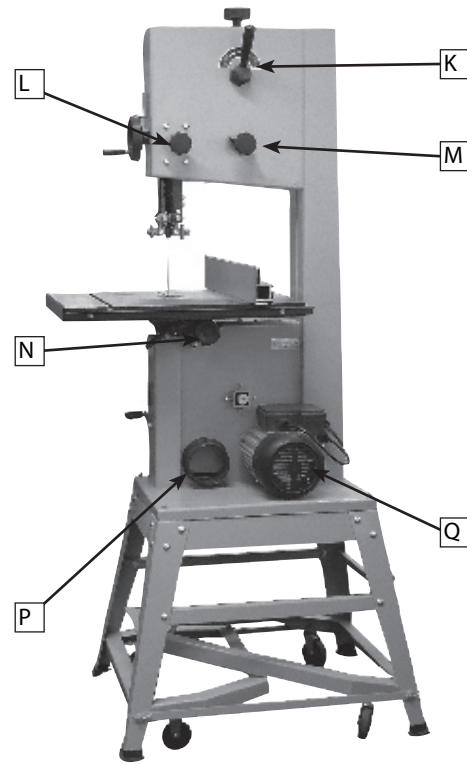
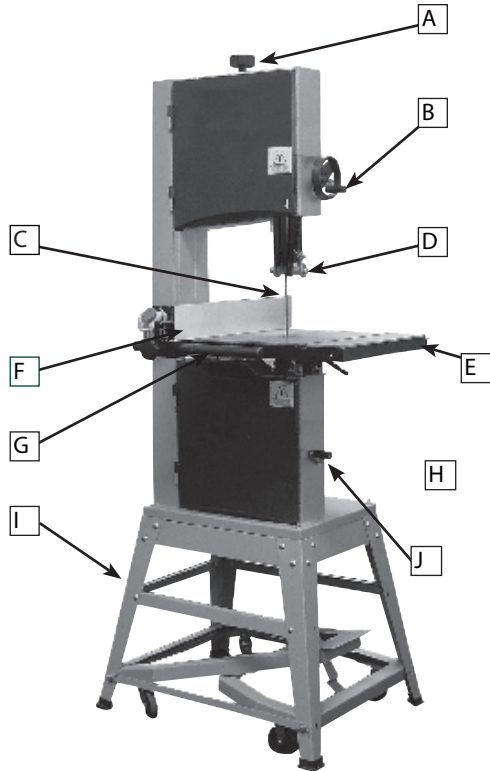

- A Blade Tensioning Knob
- B Rise & Fall Hand Wheel
- C Blade
- D Upper Blade Guide
- E Table
- F Rip Fence
- G Rip Fence Rail
- H Table Tilt Lock Handle

- I Stand (Model#10-315 doesn't include wheel kit)
- J Belt Tension & Speed Change Handle
- K Blade Tension Release Cam Handle
- L Rise & Fall Lock Knob
- M Blade Tracking Knob
- N Table Tilting Knob
- P 4" Dust Extraction Port
- Q Motor

Stand Assembly

Note: When assembling this legstand do not fully tighten the nuts and bolts until the assembly is complete.

1. Locate the first leg and secure it to one of the long top brace supports using the nuts, bolts and washers supplied Fig.1S.

2. In the same way, attach the second leg to the brace support Fig.2S.

3. Locate the short top brace supports and install to the legs as shown Fig.3.S.

4. Continue in this way until all of the legs and top brace supports have been installed Fig.4S.

5. Holes a third of the way down each leg are for securing the mid brace supports. Attach the long mid brace supports to the frame using the nuts, bolts and washers Fig.5S.

6. Finally, install the short mid brace support to one of the shorter sides Fig.6S.

Note

The side with the short mid brace support installed will be referred to as the front of the stand. This leaves the back area free for the optional wheel kit operation.

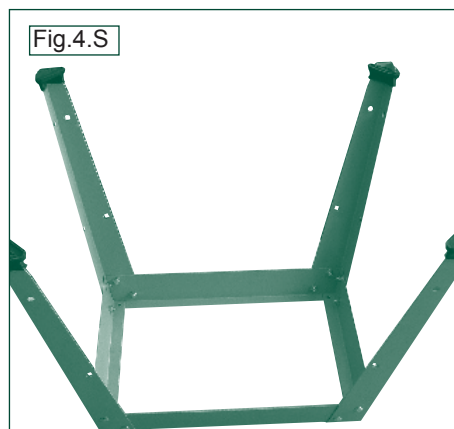
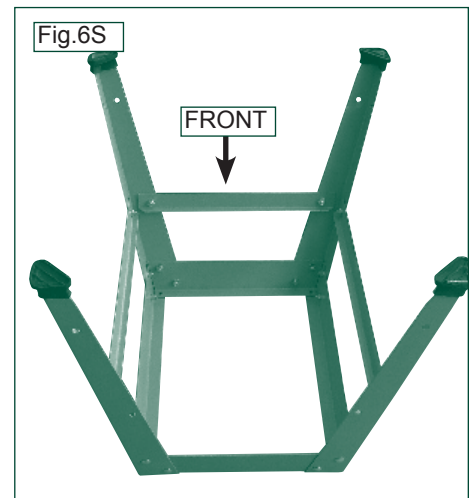
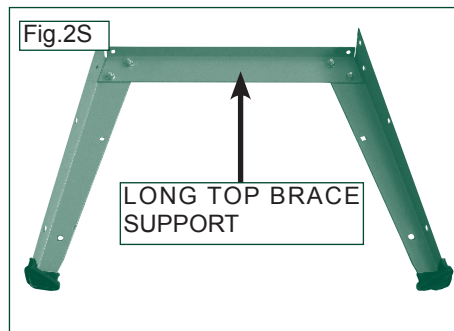
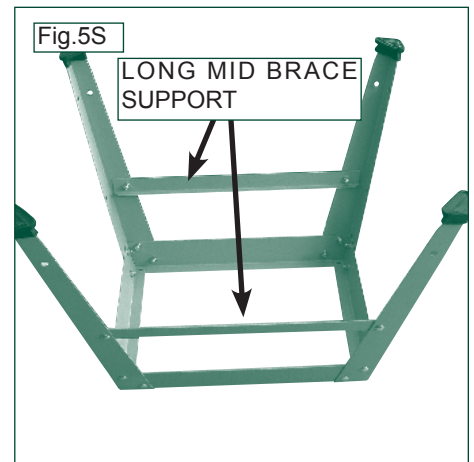
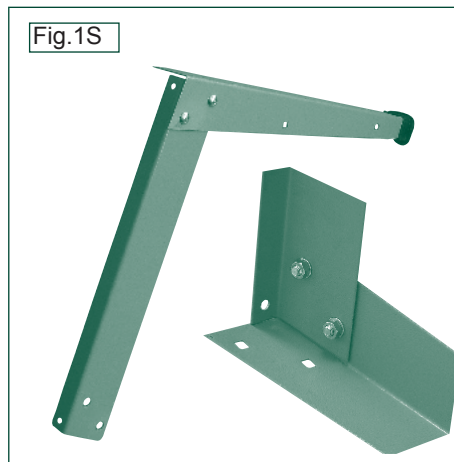

Caution: To avoid back injury, get help lifting the bandsaw. Bend your knees, lift with your legs, not your back.

Assembly

Mounting Top to Stand

Feed the long mounting bolts up through the stand and secure the four corners using the washers and bolts provided (A-Fig.1). Lift the bandsaw over the stand and place the long mounting bolts through the four location holes in the bandsaw base.

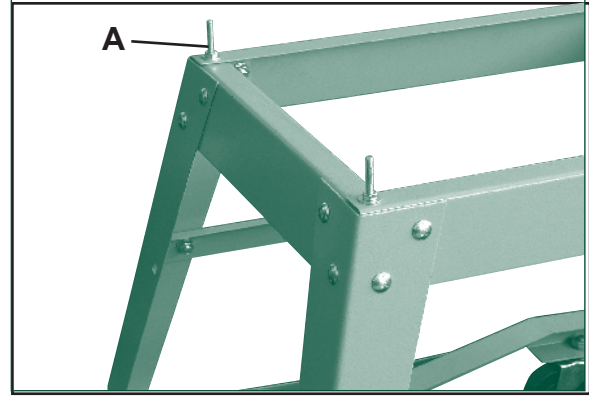

Figure 1

Assemble Working Table

Installing 90° stop: Thread screw (M8x25) and nut (M8) to the bottom of the table. (A-Fig.2) With the help of another person, lift the working table onto the trunnion. Mount the working table to the trunnion using the supplied (4) hex bolts, (4) lock washers and (4) washers (B-Fig.2). Install the two bolts to the right of the blade hand tight, then tip the table to 45 degrees and install the two bolts to the left of the blade. Adjust table parallel to blade and tighten bolts.

Table Leveling Bar: The table leveling bar is preinstalled from the factory and must be removed before installing the table. The table leveling bar keeps the two sides of the blade slot level. (C-Fig. 2)

Fence Support Bolt: Install the fence support bolt in the left rear corner of the table. (D-Fig. 2)

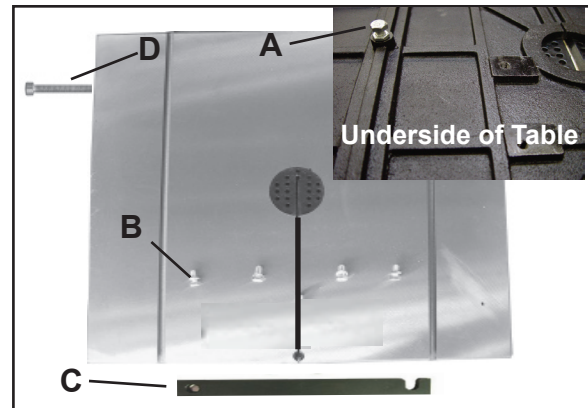

Figure 2

Rip Fence Assembly

Mount the fence bar onto the table with the two fence bar nuts.(A-Fig 3) Do not fully tighten yet as they may need to be adjusted later. The bar should be installed so that the longest amount of bar is on the left hand side allowing the fence to be attached. Place the brass lock shoe into the fence seat.(A-Fig 4) Position the fence assembly onto the fence bar(B-Fig 4). Lay the fence on to the table and lock by tightening the fence lock knob. (B-Fig 5)

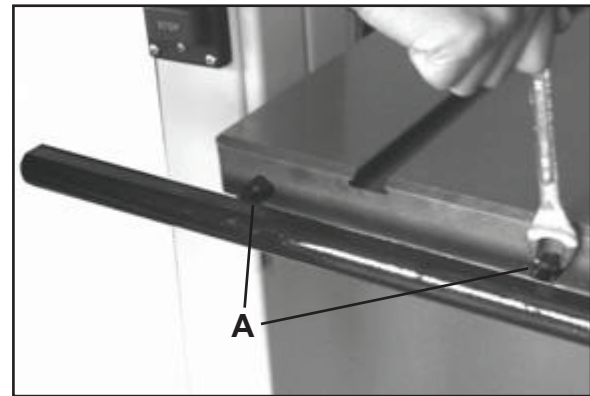

Figure 3

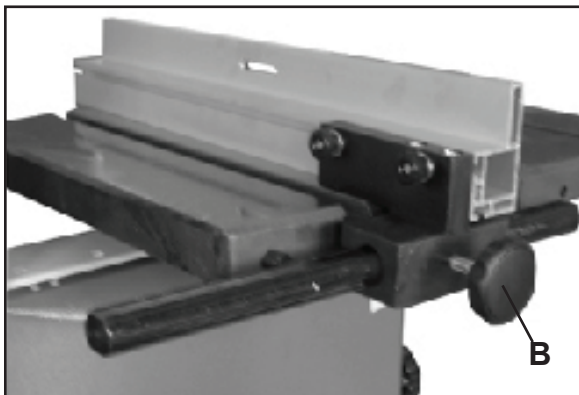

Figure 5

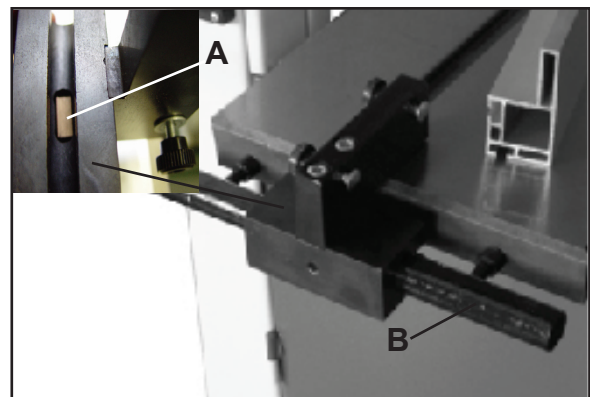

Figure 4

Installing the Tool Holder

Assemble the tool holder to the column of the bandsaw with two pan head screws. Locate the two pan head screws from the bag of loose parts. Mount the tool holder to the column and install a pan head screw in each hole, then tighten with a Phillips screw driver. (Fig. 6)

Assemble Hand-Wheels

Attach the crank handle (Fig. 7) to the rack and pinion shaft on the upper part of the bandsaw, using the 5mm “L” wrench provided.

Attach small crank handle to belt tension and speed mechanism with 10mm wrench.

Place the (4) “L” wrenches (3mm, 4mm, 5mm and 6mm) in the tool holder on the rear column support.

Installing the Guide Post Cap

Place Guide Post Cap on top of the upper wheel cabinet to the right of the Blade Tension Hand-wheel.



Figure 6

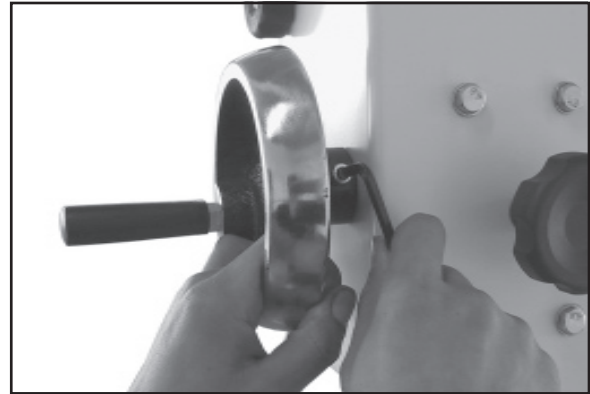

Figure 7

Adjustment

Setting the Table Square to Saw Blade

The table may be set at 90° to the saw blade sides by adjusting the table stop screw under the table. The table stop screw rests on the top of the quick release adjustment stop. By first loosening the locking nut (A-Fig. 8) and then adjusting the screw (B-Fig. 8), the table can be set correctly. Retighten the locking nut (A-Fig. 8) making sure that the setting is maintained. The angle indicator under the table can be adjusted by loosening the Phillips head screw and moving the pointer into position. (C-Fig. 8)

The table may also be set at 90° to the back of the saw blade by adjusting the trunnion micro adjustment screws. (A-Fig. 8A) First, slightly loosen two hex. bolts part 184. Using the 3mm “L” wrench, turn the rear trunnion micro adjusting screws. (Clockwise will raise the trunnion; counterclockwise will lower the trunnion). Check table for 90° and tighten part 184.

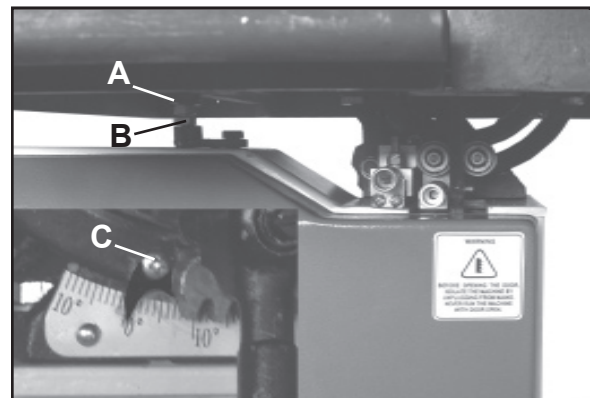

Figure 8

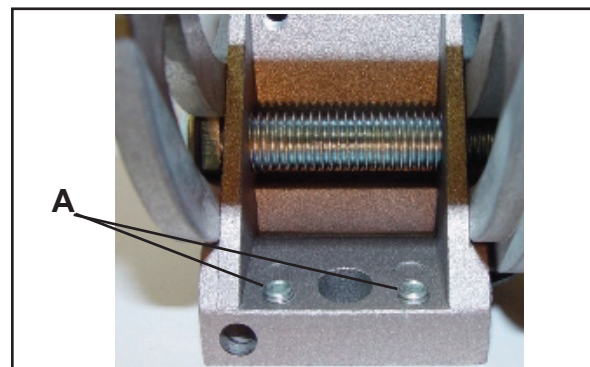

Figure 8A

Tilting the Table

Loosen the lock handle (A-Fig. 9) on the table trunnion. Turn the table tilting knob (B-Fig. 9) to adjust the table to the desired angle. Use the angle indicator scale on the trunnion bracket to find the desired angle. Retighten the lock handle to secure the table.

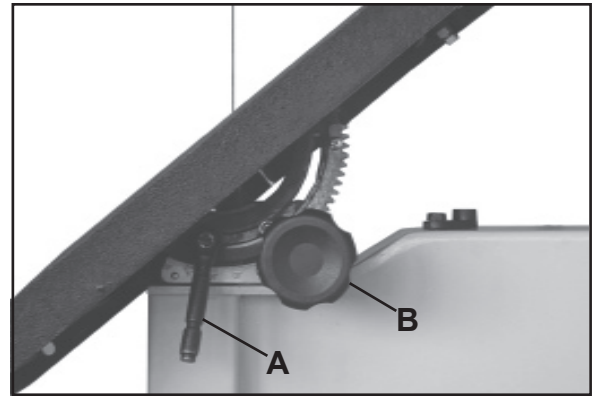

Figure 9

Tracking the Saw Blade

WARNING! Unplug the Bandsaw. First, make sure the upper and lower blade guides are adjusted away from the blade and the tension scale is set to correspond to the width of the blade you are using.

Then loosen the lock lever (A-Fig. 10) by turning it counter clockwise and turn the blade tracking knob (B-Fig. 10) clockwise/counterclockwise while turning the upper wheel by hand at least three rotations until the blade tracks centered on the wheel. Finally, tighten the lock lever and close the doors.

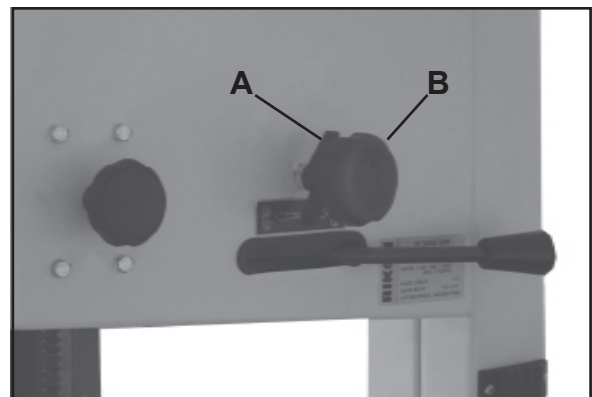

Figure 10

Adjusting the Blade Tension

To loosen the tension of the blade, turn the blade tension handwheel (A-Fig.11) counter clockwise. To tighten the tension of the blade, turn the blade tension handwheel clockwise.

Tension the blade until the tension reading corresponds to the width of blade you are using by viewing through the tension indicator window. (B-Fig.11)

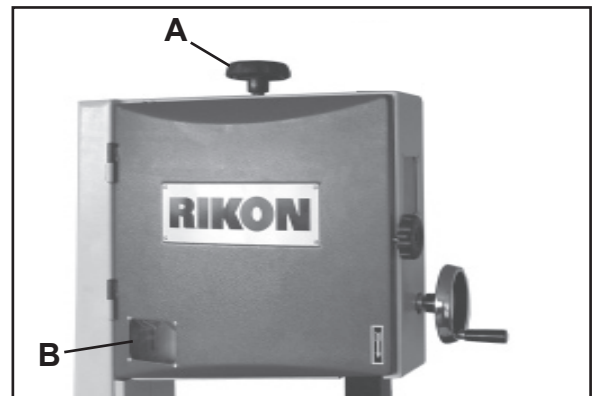

Figure 11

Adjusting the Blade Guides

Upper Guides:

a. To adjust the upper blade guides, first position the right and left roller guides relatively close to the blade by loosening the lock nut (A-Fig.12) and moving the guide carrier until both bearing guides are approximately 1/16" behind the gullets of the saw blade.

Adjustment Cont.

b. Set both bearing guides to within $1/32$ " of the saw blade by releasing the guide adjusting screws (B-Fig.12) on each side of the saw blade, then by turning the micro-adjusting knobs(C-Fig.12). Do not set the bearing guides too close as this will adversely affect the life of the saw blade.

c. Adjust the rear bearing guide to be just clear of the back of the saw blade releasing the guide adjusting screw (A-Fig.13) and by turning the micro-adjusting knob (B-Fig.13).

d. When the correct adjustment is reached, lock the bearing guide in position with the guide adjusting screw (A-Fig.13).

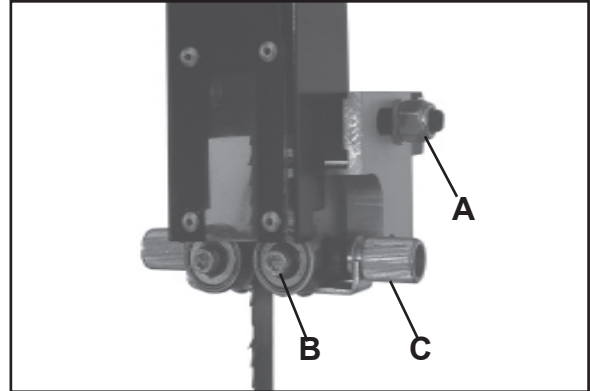

Figure 12

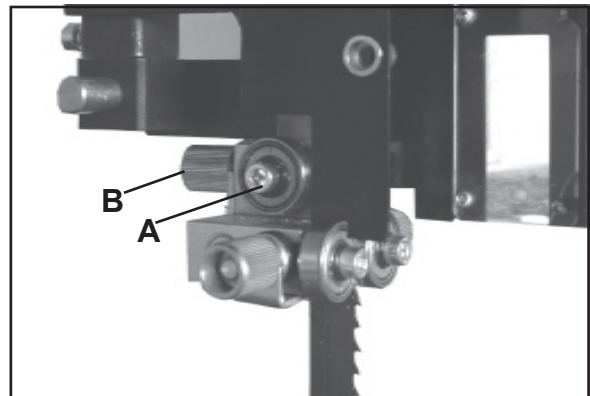

Figure 13

Lower Guides:

a. To adjust the lower blade guides, first loosen the lock nut (A-Fig.14) then move the guide carrier by the micro-adjusting knob (E-Fig.14) until both bearing guides are approximately $1/16$ " behind the gullets of the Bandsaw blade and tighten the lock nut (A-Fig.14).

b. Next set the bearing guides to within $1/32$ " of the blade by releasing the guide adjusting screw (B-Fig. 14).

c. Adjust the thrust bearing to be just clear of the back of the blade by unlocking the guide adjusting screw (C-Fig.14), and turning the micro-adjusting knob (D-Fig.14).

d. When the correct adjustments are reached, lock the bearing guides in position with the guide adjusting screws (B&C-Fig.14).

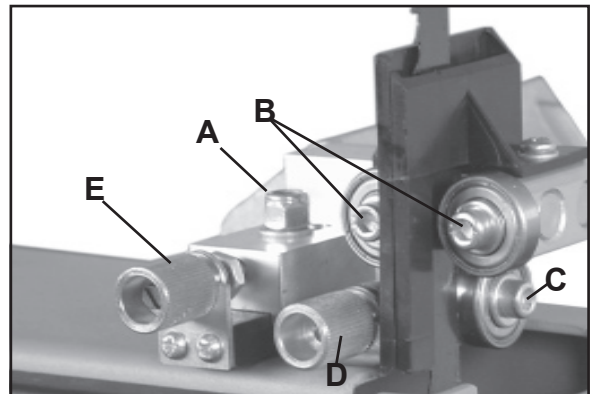

Figure 14

Adjustment Cont.

Adjusting the Rip Fence/Drift

Align the fence assembly in or out until parallel with the side of the blade by turning the adjustment collars and the fence bolts accordingly (A-Fig.15). If the mounting bolts have been tightened, these will need loosened off before this adjustment can be made. The same adjustment can be made to compensate for blade drift.

Check that the fence is 90 degrees to the table using a suitable square. If no adjustments are needed fully tighten the fence bar nuts. If adjustment is required, raise or lower either side of the fence rail until the fence body is 90 degree to the table. Once set at 90 degrees, fully tighten the fence bar nuts.

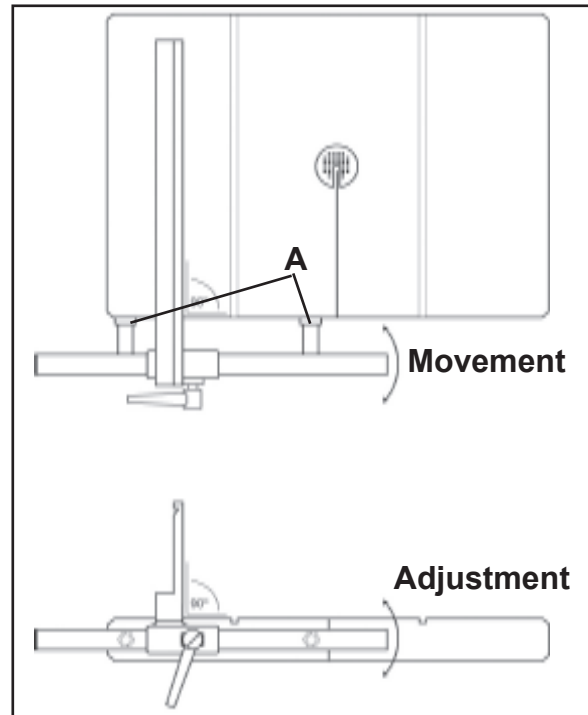

Figure 15

Adjusting the Rip Fence Guide Scale

Slide the rip fence against the blade along the rail and mark a zero position on the fence bar. Align the zero on the scale with the mark on the fence bar (Fig.16).

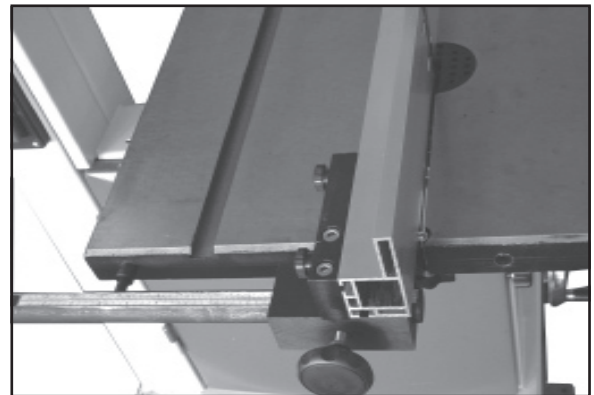

Figure 16

Cutting Height Adjustment

Loosen the guidepost lock knob (A-Fig.17) and turn the guidepost handwheel (B-Fig.17) to raise or lower the guide post/upper blade guide assembly to the desired height. Then tighten the guidepost lock knob. Note: The bottom edge of the guide bearings should be approximately 1/4" above the top surface of the work piece.

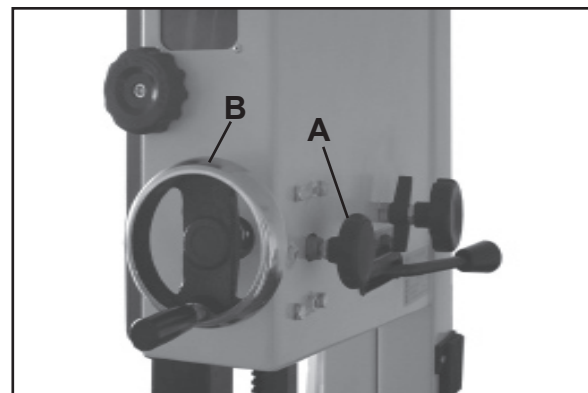

Figure 17

Changing the Blade Speed / Belt Tension

WARNING! Before changing the speed, always make sure the machine has been unplugged from the electrical supply.

This Bandsaw has two blade speeds, low speed (1445 ft/min) and high speed (2950 ft/min). The lower wheel has two integral “multi-vee” form pulleys, and the motor shaft has a twin multi-vee form pulley. The “multi-vee” belt passes around the wheel pulley and the motor pulley. The belt tension is released and applied by using the handwheel (A-Fig.18).

For the high speed (2950 ft/min), the belt should be installed on the rear pulley of both the motor and the wheel, as shown in Fig.19.

For the low speed (1445 ft/min), the belt should be installed on the front pulley of both the motor and wheel, as shown in Fig.20.

To properly adjust belt tension, turn hand-wheel (A-Fig. 18) until there is 1/2” deflection in the “multi-vee” belt.

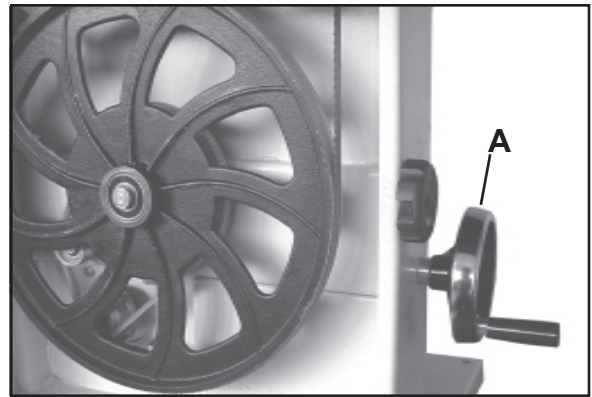

Figure 18



Figure 19



Figure 20

Replacing the Bandsaw Blade

WARNING! Unplug the machine from the electrical supply. This ensures that the Bandsaw will not accidentally turn on if the ON/OFF switch is bumped.

- a) Open the top and bottom wheel doors by turning the door locking knobs.
- b) Release the blade tension by moving the quick release lever (A-Fig.21) from right to left. Open the hinged door on the blade guard by loosening the hex screw. (A-Fig. 22 on page 15)
- c) Remove the saw blade by feeding it through the slot in the table, upper and lower blade guides and the slot in the spine of the machine, being careful not to cut yourself. Wear gloves for protection.
- d) When installing the new blade, ensure the blade teeth are pointing downwards and towards you at the position where the blade passes through the table.
- e) Center the blade on both wheels.

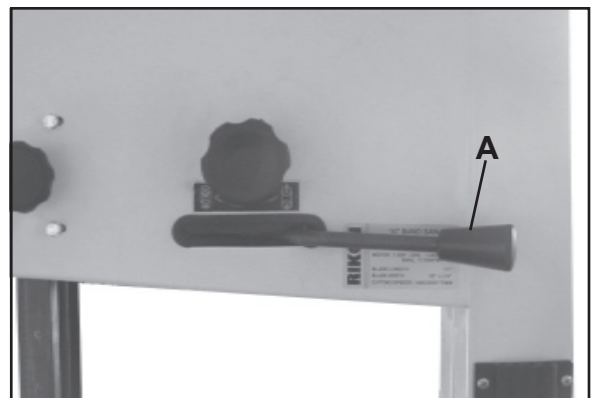

Figure 21

Replacing the Bandsaw Blade Cont.

- f) Re-tension the new blade by moving the quick release lever (A-Fig.21 on page 14) right to left and check the blade tracking. The blade should run in the center of the wheel. Refer to “Tracking the Saw Blade” on page 11 for more details.
- g) Reset the blade guides as described in the section “Adjusting the Blade Guides” on pages 11 and 12.
- h) Reset the blade tension as described in the section “Adjusting the Blade Tension” on page 11.
- i) Close the hinged door on the blade guard and tighten the hex screw. (A-Fig.22)
- j) Close and lock both the wheel doors before reconnecting the power supply.

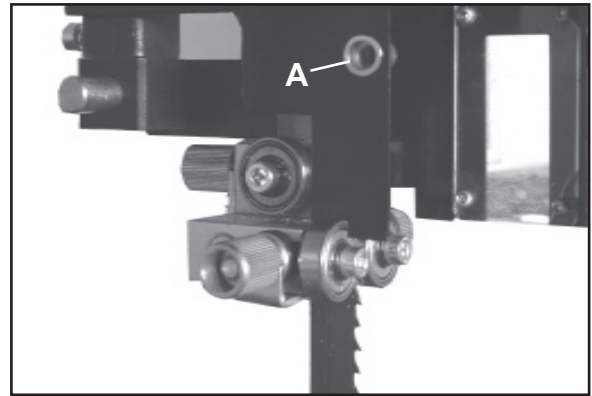

Figure 22

Re-sawing

Re-sawing

For re-sawing, attach the 3/4" x 3" post (A-Fig.23) to the slot on the fence. Position the re-saw bar so that it is aligned with the front of the blade. The re-saw bar helps to correct any blade wandering during re-sawing operations. To adjust for blade drift, refer to the section “Adjusting the Fence” on Page 13.

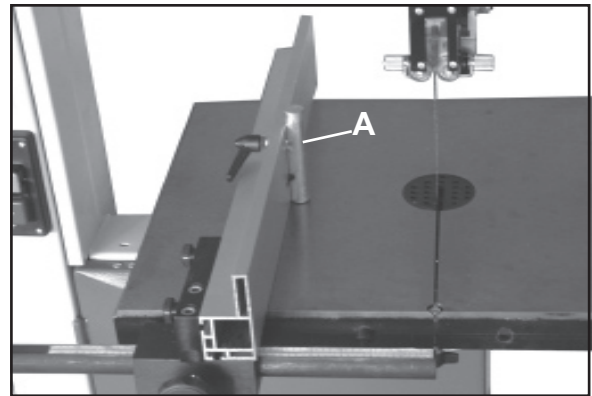

Figure 23

Operation

The blade cuts on a continuous down-stroke.

With both hands, firmly hold the workpiece down on the table, and feed it towards the blade slowly, keeping your hands away from the blade.

For best results the blade must be sharp. A dull blade will not cut correctly, especially when straight cutting, and causes excess pressure to be applied on the rear guide bearings.

Select the right blade for the job, depending on the thickness of the wood and the cut to be made.

The thinner and harder the wood, the finer the teeth of the blade should be. Use a fine tooth blade for cutting sharp curves.

The machine is especially suited for cutting curves, but will also make straight cuts. When cutting, follow the design marked out by pushing and turning the workpiece evenly.

Do not attempt to turn workpiece without pushing it as this may cause the workpiece to get stuck, or the blade to bend.

For straight cuts, use the fence provided to feed the workpiece along the blade slowly and in a straight line.

Maintenance

Caution! BEFORE CLEANING OR CARRYING OUT MAINTENANCE WORK, DISCONNECT THE MACHINE FROM THE POWER SOURCE (WALL SOCKET). NEVER USE WATER OR OTHER LIQUIDS TO CLEAN THE MACHINE. USE A BRUSH. REGULAR MAINTENANCE OF THE MACHINE WILL PREVENT UNNECESSARY PROBLEMS.

Keep the table clean to ensure accurate cutting.

Keep the outside of the machine clean to ensure accurate operation of all moving parts and prevent excessive wear.

Keep the ventilation slots of the motor clean to prevent it from overheating.

Keep the inside (near the saw blade, etc.) clean to prevent accumulation of dust.

Wiring Diagram

WARNING! This machine must be grounded. Replacement of the power supply cable should only be done by a qualified electrician.

As received from the factory, your bandsaw is ready to run at 115V operation. It can be switch to 230V according to below schematic.

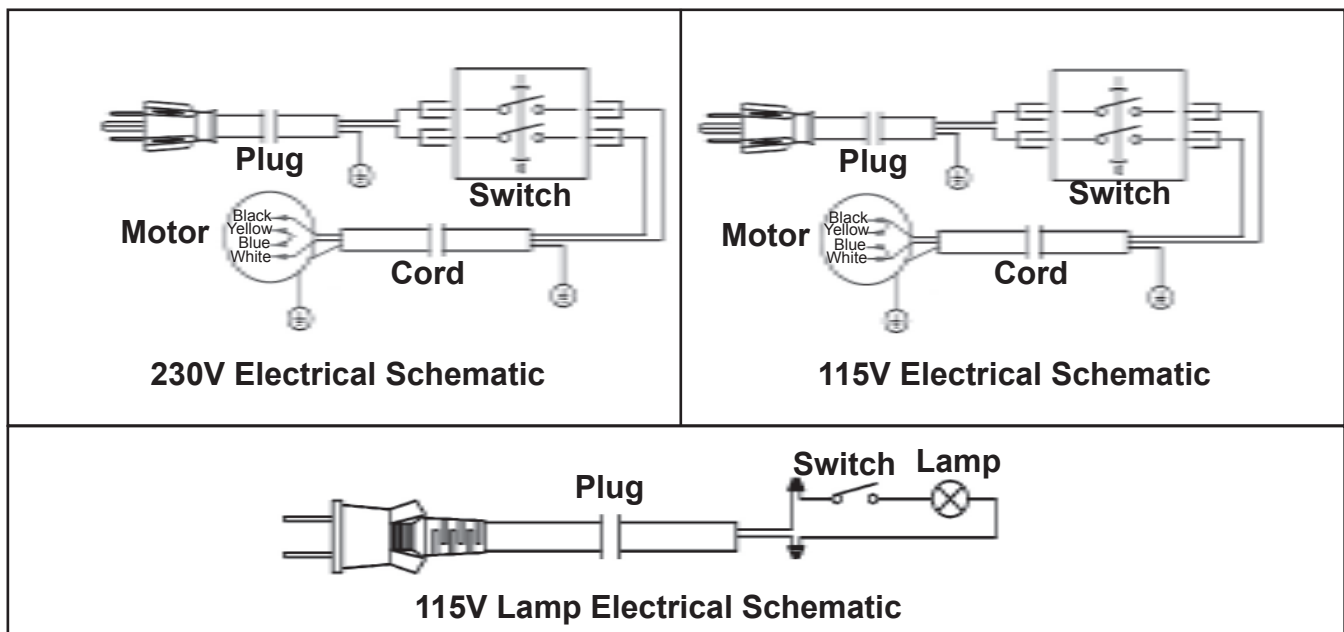

Troubleshooting

WARNING!

FOR YOUR OWN SAFETY, ALWAYS TURN OFF AND UNPLUG THE MACHINE BEFORE CARRYING OUT ANY TROUBLESHOOTING.

TROUBLE	PROBABLE CAUSE	REMEDY
The machine does not work when switched on.	<ol style="list-style-type: none"> 1. No power supply. 2. Defective switch. 	<p>Check the cable for breakage. Contact your local dealer for repair parts.</p>
The blade does not move with the motor running.	<ol style="list-style-type: none"> 1. The quick release lever or blade tension handwheel has not been tightened. 2. The blade has come off one of the wheels. 3. The saw blade has broken. 4. The drive belt has snapped. 	<p>Switch off the motor, tighten the quick release lever or blade tension handwheel. Open the hinged door and check. Replace the blade. Replace the belt.</p>
The blade does not cut in a straight line.	<ol style="list-style-type: none"> 1. Fence for cutting not used. 2. Too fast feed rate. 3. The blade teeth are dull or damaged. 4. Blade guides not suitably adjusted. 	<p>Use a fence. Put light pressure on the workpiece & make sure the blade does not bend. Use a new blade. Adjust the blade guides (see the section on page 10).</p>
The blade does not cut, or cuts very slowly.	<ol style="list-style-type: none"> 1. The teeth are dull, caused by cutting hard material or long use. 2. The blade was mounted in the wrong direction. 	<p>Replace the blade, use a 6 T.P.I. blade for wood and soft materials. Use a 14 T.P.I. blade for harder materials. A 14 T.P.I. blade always cuts slower due to the finer teeth. Install the blade correctly.</p>
Sawdust builds up inside the machine.	<ol style="list-style-type: none"> 1. This is normal 	<p>Clean the machine regularly. Open the hinged door and remove the sawdust with a vacuum cleaner. Attach a dust collection system.</p>
Sawdust inside the motor housing.	<ol style="list-style-type: none"> 1. Excessive dust build-up on the machine exterior components. 	<p>Clean the ventilating slots of the motor with a vacuum cleaner. From time to time remove the sawdust to prevent it from being drawn into the housing</p>
The machine does not cut at 45° or 90° angles.	<ol style="list-style-type: none"> 1. The table is not at right angles to the blade. 2. The blade is dull or too much pressure was put on the workpiece. 	<p>Adjust the table. Replace the blade or put less pressure on the workpiece.</p>
The blade cannot be properly positioned on	<ol style="list-style-type: none"> 1. The wheels are not aligned. 2. The blade tracking knob hasn't been properly adjusted. 3. Inferior blade. 	<p>Contact Technical Support @ 877-884-5167 or techsupport@rikontools.com. Adjust the knob (see the section on page 11). Replace the blade.</p>

For parts or technical questions contact: techsupport@rikontools.com or 877-884-5167.

Troubleshooting

Adjusting the Upper Blade Guide Bearings Parallel to the Blade

(Refer to page 19 parts diagram)

This step may not be necessary, it is factory preset. If adjustment is needed follow the steps below.

First slightly loosen part #137 (4 each) cap screw on rear of upper Bandsaw housing (see page 19 in parts diagram). This will allow you to adjust the micro adjustment screws on part #143 (Guide Bracket).

Next place a 3mm "L" wrench through one of the holes in part #139 (Guide Bracket Cover).

Turning clockwise on the left two holes will adjust the left bearings to the right. Turning clockwise on the right two holes will adjust the right bearings to the left. Check bearings for parallel.

Lastly tighten parts #137 (4) on back of Bandsaw. Repeat steps if the bearings are still not parallel.

Adjust Upper Bearings Which Will Not Track Close to the Blade

(Refer to page 19 parts diagram)

If the right or left upper bearings do not adjust to within 1/32" of the blade, the guide post (part #129) may need adjustment.

First slightly loosen parts #137 (4) on the back of the upper Bandsaw cabinet.

Next slide the upper guide post right or left until bearings are properly spaced on each side of blade. Tighten part #137 (4) on the back of the upper Bandsaw cabinet.

Leveling the Table Insert

The table insert has an innovative built in micro-adjustment feature. This adjustment can be used if the table insert sits too high or too low in the table seat. If the insert is resting above the table, turn the micro-screws with the 2.5mm "L" wrench counter clockwise to lower the insert. If the insert is sitting below the table, turn the micro-screws clockwise to raise the insert level with the table.

Caution: Having the insert below the top of the table could cause the workpiece to get stuck on the lip of the table seat.

Changing Bandsaw Tire

Use a putty knife to get underneath the tire and pull it up and away from the wheel. Work the putty knife all the way around the wheel to loosen the tire. Then, use the putty knife as leverage to flip the tire over and off of the wheel. Clean the inside of the groove, removing any dirt, debris or cement with lacquer thinner.

Soak the replacement tire in warm water to make it more flexible. Let tire dry and lay on top of wheel. Start by setting the tire into the wheel groove at the top of the wheel. Using a putty knife, work the new tire around the wheel, making sure not to slice the tire. If rubber cement is to be used, make sure to distribute evenly. Having high spots between the wheel and the tire will cause a vibration and effect blade tracking.

Parts Diagram

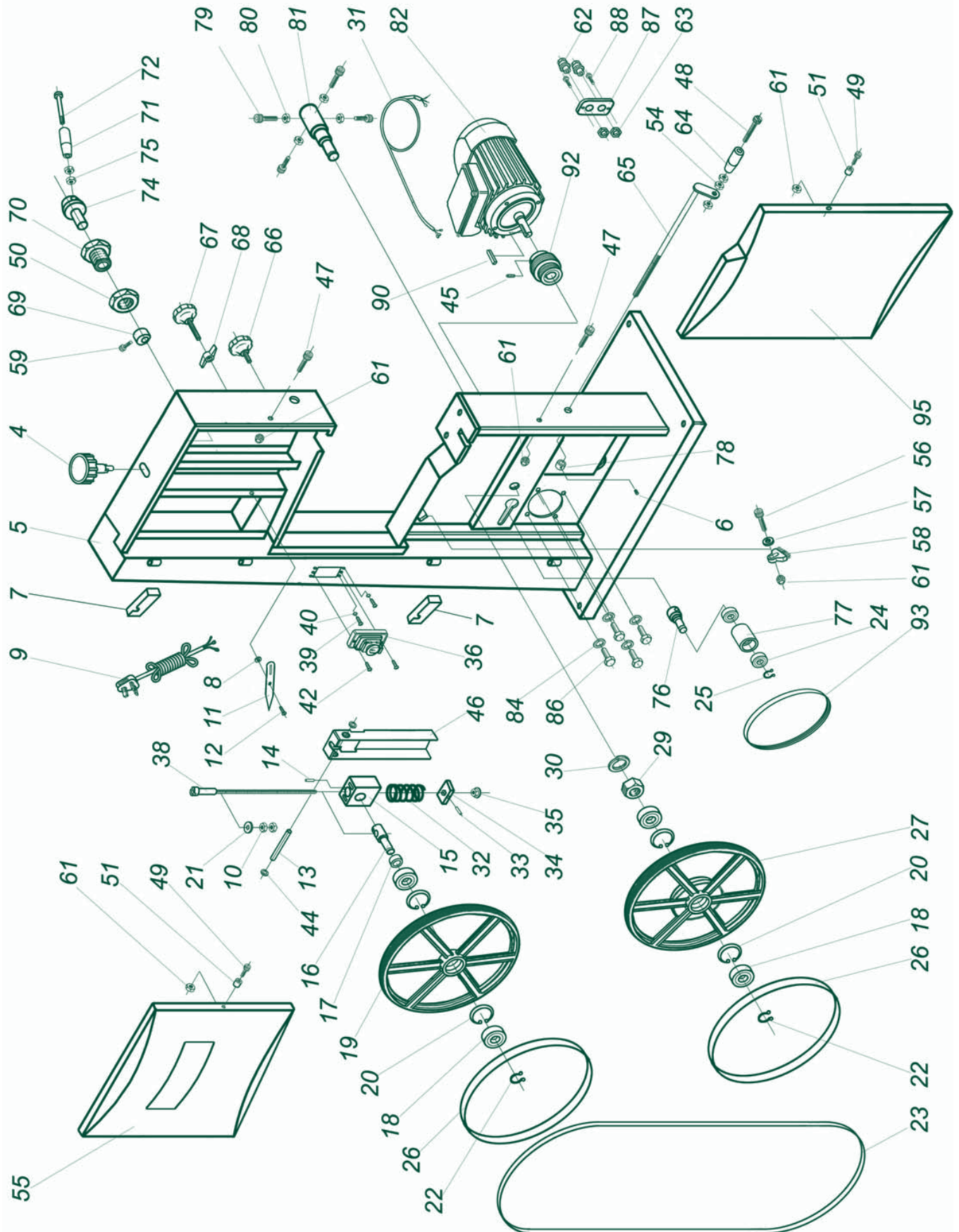

Parts Diagram Cont.

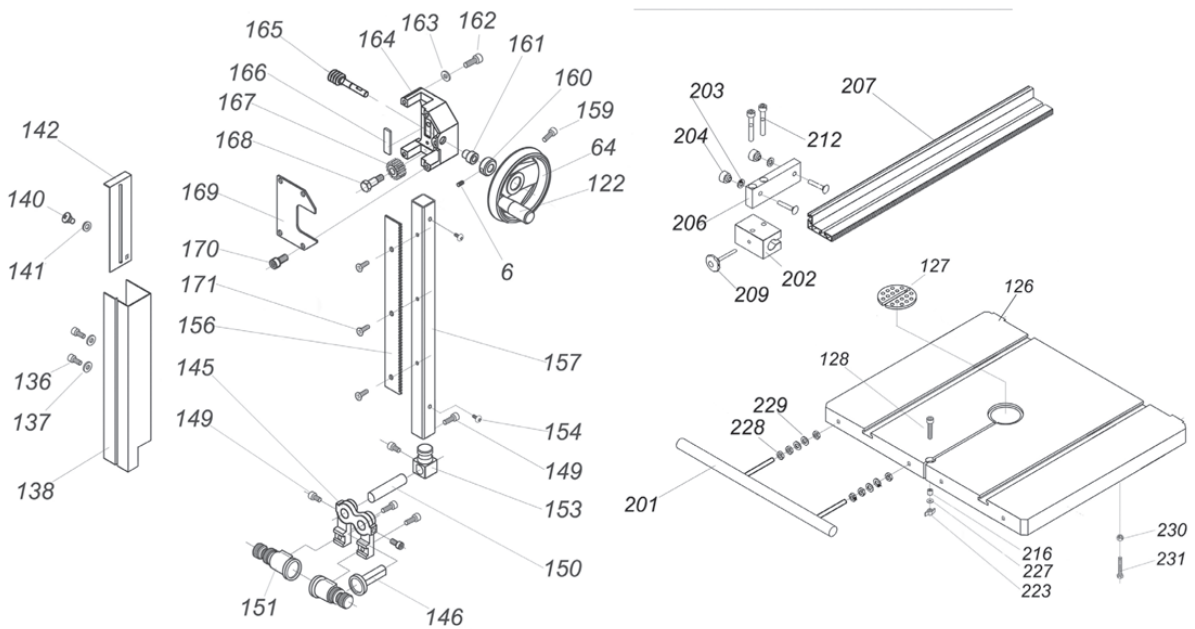
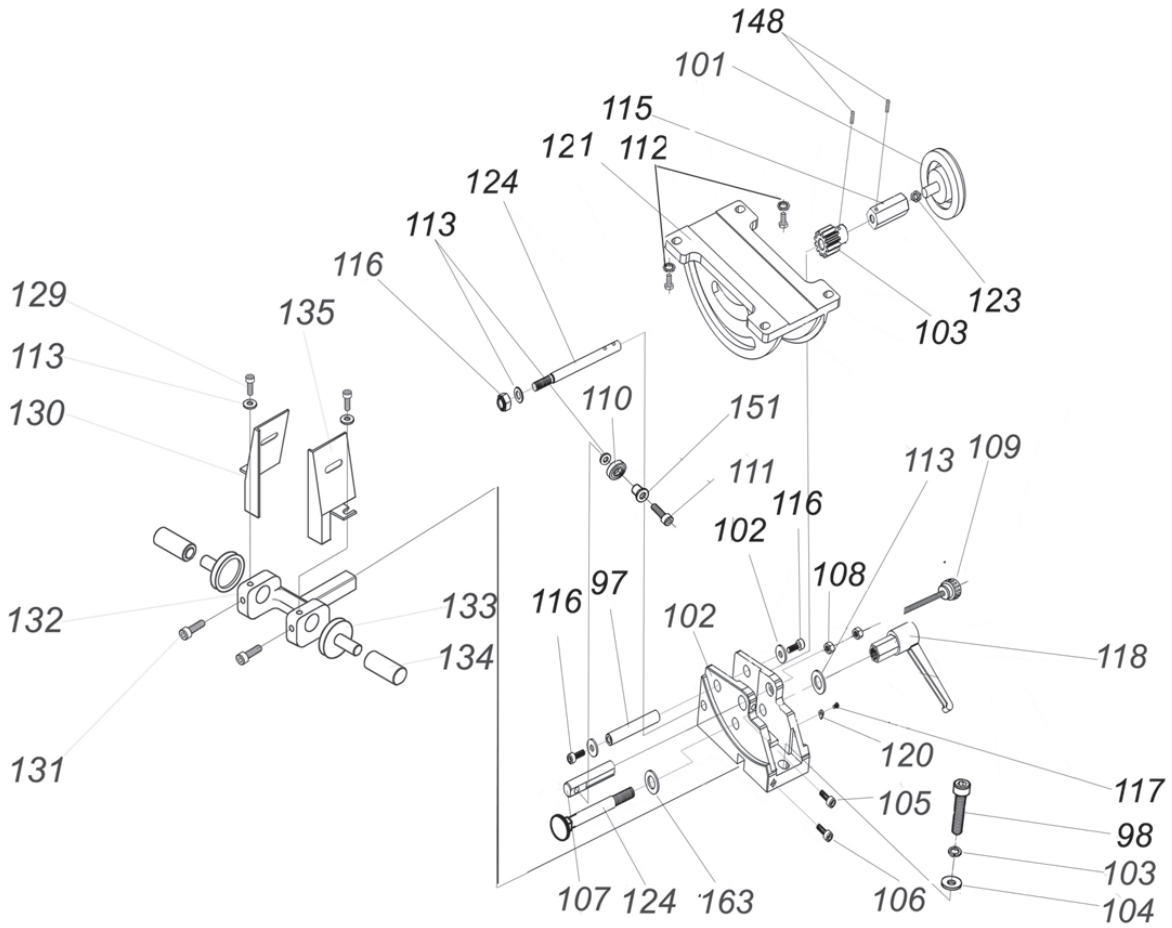

Parts Diagram Cont.

Stand

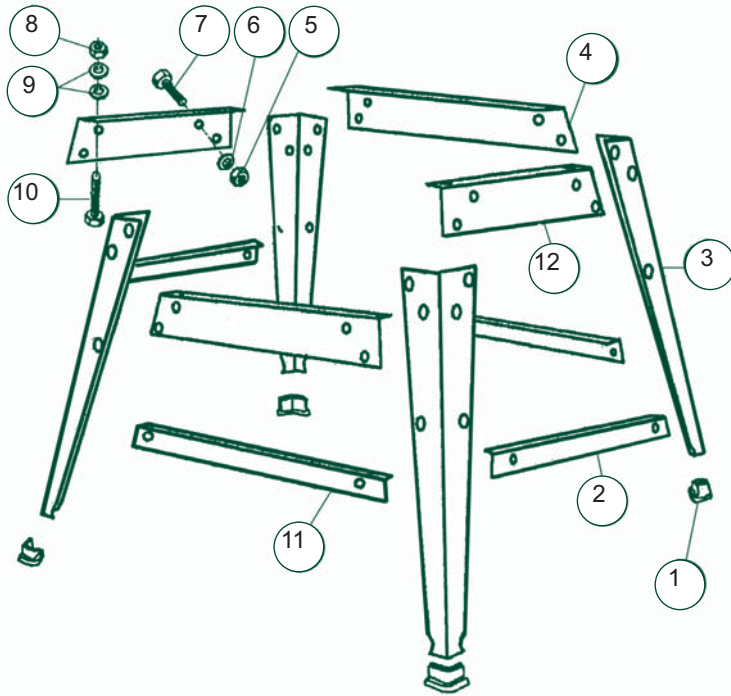

Ref No.	Description
1	Rubber shoe
2	Short mid brace support
3	Leg
4	Long top brace support
5	Hex nut
6	Washer
7	Hex bolt
8	Hex nut
9	Washer
10	Hex bolt
11	Long mid brace support
12	Short top brace support

Parts List

Ref No.	Description	Ref No.	Description
4	Blade tension knob	61	Nylon nut M6-1.0
5	Frame	62	Strain relief
6	Set screw M5-0.8x10	63	Strain relief nut
7	Safety switch	64	Crank handle
8	Flat washer M5	65	Crank
9	Power cord	66	Guide post lock knob
10	Hex nut M8-1.25	67	Blade tracking knob
11	Pointer	68	Wing nut M8
12	Step screw	69	Cam
13	Upper shaft	70	Pillow block
14	Roll Pin 5x36	71	Quick release handle
15	Upper wheel shaft hinge	72	Cap screw
16	Upper wheel shaft	74	Quick release lever seat
17	Bushing	75	Hex nut
18	Wheel Bearing	76	Sliding shaft
19	Upper wheel	77	Tension wheel
20	Int retaining ring M40	78	Set collar 10mm
21	Flat washer M8	79	Hex screw
22	Circlip ring	80	Hex nut
23	Saw blade	81	Lower wheel shaft
24	Grooved ball bearing 80101	81	Motor
25	Circlip ring 12x1	84	Lock washer M8
26	Bandwheel tyre	86	Hex screw
27	Lower wheel	87	Strain relief plate
29	Hex nut M27x2	88	Pan head screw
30	Lock washer 27	90	Key 5x5x35
31	Motor cord	92	Motor pulley
32	Spring	93	V-belt
33	Roll pin 3x16	95	Lower wheel cover
34	Block	96	Bushing
35	Bearing 51201	97	Hex socket screw M8-1.25x35
36	Switch	98	Hex socket screw M8-1.25x25
38	Adjusting rod	99	Hex nut M8
39	Pan head screw	100	Small gear
40	Star washer M5	101	Table tilt knob
42	Pan head screw	102	Trunnion support bracket
44	Hex bolt M8-1.25x16	103	Lock washer M8
45	Set screw	104	Flat washer M8
46	Slide	105	Hex socket screw M6-1.0x20
47	Hex bolt M6-1.0x25	106	Hex socket screw M6-1.0x50
48	Cap screw M6x55	107	Hollow block
49	Hex socket screw M6-1.0x20	108	Hex nut M6-1.0
50	Hex nut	109	Adjustment bolt M6-1.0
51	Bushing	110	Bearing 6201
54	Hex nut	111	Hex socket screw M8-1.25x25
55	Upper wheel cover	112	Flat washer M8
56	Hex bolt M6-1.0x25	113	Flat washer M6
57	Flat washer M6	114	Pan head screw
58	Brush	115	Table tilting shaft
59	Hex bolt M6-1.0x25	116	Nylon nut
60	Star knob	117	Pan head screw

Ref No.	Description	Ref No.	Description
118	Lock handle	206	Bracket
119	Flat washer M5	207	Rip fence
120	Pointer	209	Lock knob
121	Trunnion	212	Carriage bolt M6x35
122	Guide post handwheel handle	216	Bush
123	Hex nut	217	Lower bracket
124	Carriage bolt M6-1.0x65	223	Wing nut
126	Table	224	Cap screw
127	Table insert	228	Hex nut M8
128	Hex socket screw M6-1.0x50	229	Wing screw
129	Hex socket screw	230	Hex nut M8
130	Left cover	231	Hex bolt M8-1.25x30
131	Hex socket screw		
132	Lower blade guide support		
133	Lock washer		
134	Shaft		
135	Right cover		
136	Hex bolt		
137	Flat washer		
138	Protective cover		
140	Step screw		
141	Flat washer		
142	Sliding plate		
145	Upper blade guide bracket		
146	Blade support shaft		
148	Pin		
149	Hex socket screw		
150	Adjust bar		
151	Pin		
153	Upper guide support block		
154	Pan head screw		
156	Rack		
157	Upper guide hose		
159	Hex socket screw		
160	Bushing		
161	Bushing		
162	Cap screw M6-1.0x16		
163	Spring washer 6		
164	Guide bracket		
165	Worm cylinder		
166	Fixed plate		
167	Gear		
168	Fixed bolt		
169	Cover		
170	Hex bolt M8-1.25x16		
171	Pan head screw		
201	Fence rail		
202	Fence seat		
203	Washer		
204	Knob		

How-To's for all Band Saw Blades

Choosing the Correct Blade Width

Blade width is measured from the tips of the teeth to the back edge of the blade as shown above. The instructions for the particular machine being used should be followed when selecting blade width.



If no such instructions are provided, blade width should be determined with the following guidelines:

For Cut-Off Sawing, the blade should be as wide as the machine will allow. The wider the band is, the straighter the cut will be. Faster feeding can be achieved.

For Contour Sawing, the blade should be as wide as the machine allows, but still narrow enough so that it can cut the desired shape (radius). Minimum dimensions for different cutting radii are shown on the chart at right.

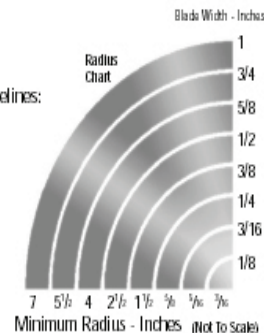

How To Choose The Correct Number Of Teeth Per Inch (TPI)

The number of teeth per inch (TPI) is important in obtaining the finish desired and the proper feed rate. A coarse tooth blade (2, 3 TPI) should be used for resawing wood and cutting thicker stock up to 8". A fine toothed blade (18 to 32 TPI) should be used for thinner metals and plastics under 1/4". For general cutting of 3/4" wood 4 TPI will provide a fast cut and 14 TPI will cut slow, but leave a smoother finish.

When Selecting TPI remember:

- More TPI give a smoother but slower cut
- Fewer TPI allow a faster cut with a slightly rougher finish
- At least three teeth must be in the workpiece—the chart to the right will help you decide.

TPI	Minimum Material Thickness
32	3/32"
24	1/8"
18	5/32"
14	1/4"
10	5/16"
8	3/8"
6	1/2"
4	3/4"
3	1"
2	1-1/2"

It is important to know the SFM for the various speed settings of your band saw, so that you can select the proper speed for cutting wood or other materials. Check the operator's manual of your band saw to determine the SFM or use the following procedure:

1. Determine the RPM: check the operator's manual or clock the revolutions per minute of the wheels with a tachometer or revolution counter.
2. Measure the diameter of the drive wheel in inches and multiply by .262 to obtain the wheel circumference. The RPM times circumference equals the surface speed of the blade.
 $RPM \times \text{diameter in inches} \times .262 = SFM.$

Note: Spring Steel Wood Cutting Band Saw Blades should never be operated at surface speeds above 3000 SFM. Carbon Hard Edge Flexible Back Band Saw Blades may be run up to 8000 SFM.

Installing your Band Saw Blade

1. Unplug the saw, then loosen the tension on the upper wheel. With all the blade guides backed off, slip the new blade around the wheels and then tension it.
2. When you have tensioned the blade enough to keep it on the wheels, track it by turning the upper wheel with one hand while adjusting the tilt of the wheel's axis with the other hand. The blade should ride in the middle of the rim. **Never track the blade with the motor running and the cover open.**
3. Next, adjust the blade guides; first the thrust bearings: upper and lower, then the left and side guides.
4. Use a square to make sure you are not pushing the blade out of line and place a piece of white paper between the blade guide and the blade to allow for clearance.

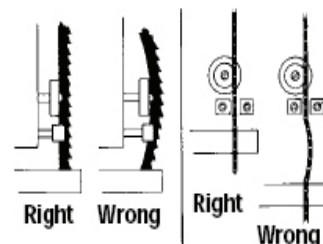

Diagnosing Problems

1. Premature and Excessive Tooth Wear

- Feed pressure too light, increase it.
- Lower band velocity.
- Improper tooth selection, use a finer pitch.
- Improper break-in with new band. Velocity and feeding should be reduced the first few cuts.
- Teeth are running the wrong direction.
- Be sure teeth are pointing in proper direction.
- Incorrect saw guide insert size for the band, allowing them to strike teeth

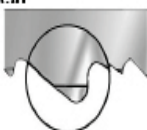

2. Blade Vibration

- Increase or decrease band velocity.
- Teeth too coarse for workpiece.
- Material not securely held.
- Increase tension of band.
- Increase feed pressure.

3. Gullets Loading

- Teeth too fine for workpiece - use a coarser pitch.
- Decrease band velocity.

4. Band Stalls in Work

- Feed pressure too great - decrease feed.
- Teeth too coarse, use finer tooth blade



5. Premature Blade Breakage

- Thickness of blade too heavy for diameter of wheels and speed of machine
- Increase or decrease velocity
- Check wheels for defects
- Teeth too coarse for workpiece - use a finer pitch
- Decrease blade tension - decrease feeding force
- Brittle weld - increase annealing period, decreasing heat gradually
- Check for proper adjustment of band guides, saw guides, saw guide inserts, and back-up bearings.

6. Blade Making Belly-Shaped Cuts

- Increase tension.
- Adjust guides closer to workpiece.
- Teeth too fine - use a coarse pitch.
- Decrease feed force.
- Teeth dull.



7. Tooth Strippage

- Teeth too coarse for workpiece.
- Material not securely held.
- Too much feed pressure - reduce for good chip curl.
- Band velocity too low - increase speed.



8. Band Develops a Negative Camber

- Band is riding on saw guide backup bearing too heavily. Adjust band for alignment on top and bottom wheels.
- Check band wheel alignment.



9. Blade Not Running True Against Saw Guide Backup Bearing

- If clicking noise against saw guide backup bearing, remove burr on band.
- Check band wheel alignment.
- Check saw guide backup bearing for wear, replace if necessary
- Weld not in proper alignment. Reweld blade straight and true.

10. Cutting Rate Too Slow

- Increase band velocity.
- Use a coarser pitch.
- Increase feed pressure.



11. Blade Leading In Cut

- Reduce feed pressure or rate.
- Check adjustments and wear of saw guides or rollers.
- Lack of band tension.
- Tooth set damage.



12. Premature Loss of Set

- Improper width selection - check chart for correct width for radius cutting.
- Reduce band velocity.

13. Band Develops Positive Camber

- Decrease force.
- Use a coarser pitch to increase tooth penetration.
- Adjust saw guides closer to work.



14. Band Develops Twist

- Wrong width for radius being cut - choose a narrower blade.
- Binding in cut - decrease feed pressure.
- Decrease band tension.
- Adjust saw guides further from workpiece.



15. Finished Cut Surface Too Rough

- Improper tooth selection - choose a finer pitch.
- Increase band velocity.
- Decrease feed rate.



16. Band Scoring (side wear or grooving)

- Check for wear on saw guide inserts.
- Too much pressure on saw guide inserts.
- Check alignment of saw guides - be sure they are square to front vise. Replace or clean guides.



17. Burring or Mushrooming of Blade Back Edge

- Increase tension and adjust guides.
- Check contact between blade and back edge rollers.
- Reduce feed pressure.
- Use coarser pitch blade.
- Use finishing stone.



Warranty



5-Year Limited Warranty

RIKON Power Tools (“Seller”) warrants to only the original retail consumer/purchaser of our products that each product be free from defects in materials and workmanship for a period of five (5) years from the date the product was purchased at retail. This warranty may not be transferred.

This warranty does not apply to defects due directly or indirectly to misuse, abuse, negligence, accidents, repairs, alterations, lack of maintenance or normal wear and tear. Under no circumstances will Seller be liable for incidental or consequential damages resulting from defective products. All other warranties, expressed or implied, whether of merchantability, fitness for purpose, or otherwise are expressly disclaimed by Seller. This warranty does not cover products used for commercial, industrial or educational purposes.

This limited warranty does not apply to accessory items such as blades, drill bits, sanding discs or belts and other related items.

Seller shall in no event be liable for death, injuries to persons or property, or for incidental, contingent, special, or consequential damages arising from the use of our products.

To take advantage of this warranty proof of purchase documentation, which includes date of purchase and an explanation of the complaint, must be provided.

The Seller reserves the right to effect at any time, without prior notice, those alterations to parts, fittings, and accessory equipment which they may deem necessary for any reason whatsoever.

To take advantage of this warranty, please fill out the enclosed warranty card and send it to:
RIKON Warranty
16 Progress Rd.
Billerica, MA 01821

The card must be entirely completed in order for it to be valid. If you have any questions please contact us at 877-884-5167 or warranty@rikontools.com.

Notes

Notes



**For more information:
16 Progress Rd.
Billerica, MA 01821**

**877-884-5167/978-528-5380
techsupport@rikontools.com
www.rikontools.com**