

OWNER'S MANUAL

MODEL NO.s

BBS-1560 BBSF-2535
BBSF-1565 T-1500



CAUTION

For Operation
Read Rules And
Instructions Carefully

STATEMENT OF POLICY

It is the policy of **Farm Star** to improve its products where it is possible and practical to do so. **Farm Star** reserves the right to make changes or improvements in design and construction at any time without incurring the obligation to make these changes on previously manufactured units.

Safety Instructions
Assembly & Mounting
Operating Instructions

Maintenance
Repair Parts

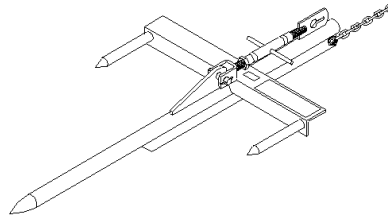

BBS-1560

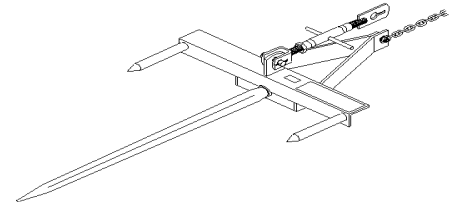

BBSF-1565

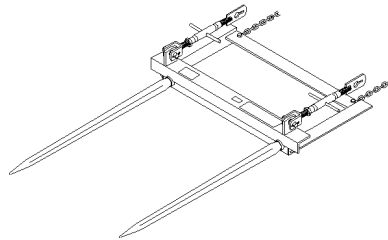

BBSF-2535

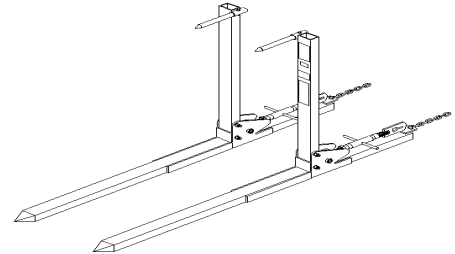

T-1500

LOADER BUCKET ATTACHMENT(S) (CLAMP-ON)



CAUTION

**THE FOLLOWING SAFETY PRECAUTIONS SHOULD BE THOROUGHLY UNDERSTOOD
BEFORE ATTEMPTING TO BEGIN ASSEMBLING THIS MACHINE.**

1. Select an area for assembly that is clean and free of any debris which might cause persons working on the assembly to trip.
2. Do not lift heavy parts or assemblies. Use crane, jack, tackle, fork trucks or other mechanical devices.
3. Preview the assembly instructions in your operators manual before proceeding further.
4. If the assembly instructions call for parts or assemblies to be blocked up, use only blocking material that is in good condition and is capable of handling the weight of the assembly to be blocked. Also insure that the blocking material is on a clean, dry surface.
5. Never put hands, or any other part of body under blocked up assemblies if at all possible.
6. After completing assembly, thoroughly inspect the machine to be sure that all nuts, bolts, hydraulic fittings or any other fastened assemblies have been thoroughly tightened.
7. Before operating the machine, thoroughly read the operation section of your operator's manual.
8. Before operation, read the maintenance section of your operator's manual to be sure that any parts requiring lubrication such as gearboxes are full to avoid any possible damage.
9. **Before operating equipment. If you have any questions regarding the proper assembly or operation, contact your Farm Star dealer or representative.**

FARM STAR

P.O BOX 1000, LITCHFIELD, IL. 62056-100

Phone: 217-324-5973 Fax: 217-324-3356 Web Site: www.farmstar.com

To the Owner/Operator/Dealer

All implements with moving parts are potentially hazardous. There is no substitute for a cautious, safe-minded operator who recognizes the potential hazards and follows reasonable safety practices. The manufacturer has designed this implement to be used with all its safety equipment properly attached, to minimize the chance of accidents.

BEFORE YOU START!!

Read the safety messages on the implement and shown in your manual.

Observe the rules of safety and common sense!



THIS SYMBOL MEANS

--ATTENTION!

--BECOME ALERT!

--YOUR SAFETY IS INVOLVED!

THIS SAFETY ALERT SYMBOL IDENTIFIES IMPORTANT SAFETY WARNING MESSAGES. CAREFULLY READ EACH WARNING MESSAGE THAT FOLLOWS. FAILURE TO UNDERSTAND AND OBEY A SAFETY WARNING, OR RECOGNIZE A SAFETY HAZARD, COULD RESULT IN AN INJURY OR DEATH TO YOU OR OTHERS AROUND YOU. THE OPERATOR IS ULTIMATELY RESPONSIBLE FOR THE SAFETY OF HIMSELF, AS WELL AS OTHERS IN THE OPERATING AREA OF THE TRACTOR AND ATTACHED EQUIPMENT.

UNDERSTAND SIGNAL WORDS

Note the use of the signal words **DANGER**, **WARNING** and **CAUTION** with the safety messages. The appropriate signal word for each has been selected using the following guidelines:

DANGER: Indicates an imminently hazardous situation that, if not avoided, will result in death or serious injury. This signal word is to be limited to the most extreme situations typically for machine components, which, for functional purposes, cannot be guarded.

WARNING: Indicates a potentially hazardous situation that, if not avoided, could result in death or serious injury, and includes hazards that are exposed when guards are removed. It may also be used to alert against unsafe practices.

CAUTION: Indicates a potentially hazardous situation that, if not avoided, may result in minor or moderate injury. It may also be used to alert against unsafe practices.

If you have questions not answered in this manual or require additional copies or the manual is damaged, please contact your dealer or the manufacturer directly.

IMPORTANT SAFETY INFORMATION!

Working with unfamiliar equipment can lead to careless injuries. Read this manual, and the manual for your tractor, before assembly or operating, to acquaint yourself with the machines. It is the implement owner's responsibility, if this machine is used by any person other than yourself, is loaned or rented, to make certain that the operator, prior to operating:

1. Reads and understands the operator's manuals.
2. Is instructed in safe and proper use.



The use of this equipment is subject to certain hazards, which cannot be protected against by mechanical means or product design. All operators of this equipment must read and understand this entire manual, paying particular attention to safety and operating instructions, prior to using. If there is something in this manual you do not understand, ask your supervisor, or your dealer, to explain it to you.

SAFETY INSTRUCTIONS (continued)



EQUIPMENT SAFETY GUIDELINES



Never use alcoholic beverages or drugs which can hinder alertness or coordination while operating this equipment. Consult your doctor about operating this machine while taking prescription medications.



Review the safety instructions with all users annually.



This equipment is dangerous to children and persons unfamiliar with its operation. The operator should be a responsible adult familiar with farm machinery and trained in this equipment's operations. **Do not allow persons to operate or assemble this unit until they have read this manual and have developed a thorough understanding of the safety precautions and of how it works.**



To prevent injury or death, use a tractor equipped with a Roll-Over Protective System (ROPS). Do not paint over, remove or deface any safety signs or warning signs on your equipment. Observe all safety signs and practice the instructions on them.



Never exceed the limits of a piece of machinery. If its ability to do a job, or to do so safely, is in question – DON'T TRY IT.



Do not modify the equipment in any way. Unauthorized modification may impair the function and/or safety and could affect the life of the equipment.



In addition to the design and configuration of this implement, including Safety Signs and Safety Equipment, hazard control and accident prevention are dependent upon the awareness, concern, prudence, and proper training of personnel involved in the operation, transport, maintenance, and storage of the machine. Refer also to Safety Messages and Operation Instructions in each of the appropriate sections of the Tractor and Loader Manuals. Pay close attention to the Safety Signs affixed to the Tractor and the Loader.



SAFETY SIGNS



Keep safety signs clean and legible at all times.



Replace safety signs that are missing or have become illegible.



Replaced parts that displayed a safety sign should also display the current sign.



Safety signs are available from your Distributor or Dealer Parts Department or the factory.

How to Install Safety Signs:







Be sure that the installation area is clean and dry.



Be sure temperature is above 50°F (10°C).







SAFETY INSTRUCTIONS (continued)

How to install Safety Signs (continued)

-  Decide on the exact position before you remove the backing paper.
-  Remove the smallest portion of the split backing paper.
-  Align the sign over the specified area and carefully press the small portion with the exposed sticky backing in place.
-  Slowly peel back the remaining paper and carefully smooth the remaining portion of the sign in place.
-  Small air pockets can be pierced with a pin and smoothed out using the piece of sign backing paper.

















SAFETY TRAINING

-  Safety is a primary concern in the design and manufacture of our products. Unfortunately, our efforts to provide safe equipment can be wiped out by a single careless act of an operator.
-  In addition to the design and configuration of equipment, hazard control and accident prevention are dependent upon the awareness, concern, prudence and proper training of personnel involved in the operation, transport, maintenance and storage of equipment.
-  It has been said, “The best safety device is an informed, careful operator”. We ask you to be that kind of an operator. It is the operator’s responsibility to read and understand ALL Safety and Operating instructions in the manual and to follow these. Accidents can be avoided.
-  Working with unfamiliar equipment can lead to careless injuries. Read this manual, and the manual for your tractor, before assembly or operating, to acquaint yourself with the machines. It is the equipment owner’s responsibility, if this machine is used by any person other than yourself, is loaned or rented, to make certain that the operator, prior to operating:
 1. Reads and understands the operator’s manuals.
 2. Is instructed in safe and proper use.
-  Know your controls and how to stop tractor, engine, and implement quickly in an emergency. Read this manual and the one provided with your tractor.
-  Train all new personnel and review instructions frequently with existing workers. A person who has not read and understood all operating and safety instructions is not qualified to operate the machine. An untrained operator exposes himself and bystanders to possible serious injury or death.
-  Do not allow children to operate this machine.

SAFETY INSTRUCTIONS (continued)



OPERATIONAL SAFETY

-  The use of this equipment is subject to certain hazards, which cannot be protected against by mechanical means or product design. All operators of this equipment must read and understand this entire manual, paying particular attention to safety and operating instructions, prior to using. If there is something in this manual you do not understand, ask your supervisor, or your dealer, to explain it to you.
-  Personnel protection equipment including hardhat, safety glasses, safety shoes, and gloves are recommended during assembly, installation, operation, adjustment, maintaining, repairing, removal, or moving the implement. Do not allow long hair, loose fitting clothing or jewelry to be around moving parts.
-  Never permit any person other than the operator to ride or board the tractor or implement at any time. **ALLOW NO RIDERS!**
-  The use of any loader attachment is NOT recommended on tractors with a tricycle wheel arrangement. Tricycle type tractors are unstable for front loader use.
-  A heavy load can cause instability in driving a tractor. Make sure the front or rear of the tractor is properly counter-balanced with weights. Always drive slowly – especially around turns. An unstable tractor could steer badly and possibly tip over, causing injury or death.
-  Most accidents occur because of neglect or carelessness. Keep all helpers and bystanders at a safe distance. **REMEMBER FALLING BALES CAN ROLL OR TUMBLE.**
-  Beware of low electrical wires when loader is raised. Serious injury or death can result if contact is made.
-  Always insert spears into the bale – NEVER under the bale. Failure to insert spears into abale can allow bale to roll back when loader is raised, causing serious injury or death.
-  Do not handle bales that exceed the bale weight limitations of the loader.
-  Carry the bale slowly and as low as possible to the ground.
-  Operate the loader controls smoothly, avoiding jerky operation.
-  When handling round bales on a slope, always approach the bale with the tractor facing uphill.
-  Never use the tractor/loader to stop a rolling bale.
-  Only use a tractor equipped with a ROPS cab or rollover protective structure.
-  When stacking bales, **ALWAYS MAKE SURE BALES ARE PLACED SO THE STACK IS STABLE.**

SAFETY INSTRUCTIONS (continued)



OPERATIONAL SAFETY (continued)



For operator safety, always keep bale in front of the tractor hood. NEVER position bale back over operator. ALWAYS BE CAREFUL!



Always load rear of tractor first and unload last when using a front loader.



Beware of lift clearance when raising loader to maximum height.



Keep alert and watch the rear as well as the front when working with the loader.



When maneuvering close to buildings or passing through narrow areas, be sure to allow sufficient clearance for the tractor, loader, and bale. Drive slowly.



Operate loader from operator's seat only. Remain at controls until operating cycle is complete.



Stop loader gradually when lowering or lifting loads.



Allow for additional length of loader and bale on tractor while turning.



Never allow anyone to walk or work under a raised loader.



Be sure that people, livestock, or pets are not standing near the machine while operating.



Do not use loader for a work platform.



Do not lift or carry anyone on loader or in bucket or on attachment.



ALWAYS lower loader to the ground or block securely before performing any maintenance work.



Stay alert for holes, rocks and roots in the terrain and other hidden hazards. Keep away from drop-offs.



Use extreme care and maintain minimum ground speed when transporting on hillside, over rough ground and when operating close to ditches or fences. Be careful when turning sharp corners.



Reduce speed on slopes and sharp turns to minimize tipping or loss of control. Be careful when changing directions on slopes. Do not start or stop suddenly on slopes. Avoid operation on steep slopes.

SAFETY INSTRUCTIONS (continued)



OPERATIONAL SAFETY (continued)



When using a unit, a minimum 20% of tractor and equipment weight must be on tractor front wheels. Without this weight, tractor could tip over, causing personal injury or death. The weight may be attained with a front-end loader, front wheel weights, and ballast in tires of front tractor weights. When attaining a minimum 20% of tractor and equipment weight on the front wheels, you must not exceed the ROPS weight certification. Weigh the tractor and equipment. Do not guess or estimate!



Avoid excessive speed during operation.



ALWAYS lower spear points to the ground when parking tractor. Raised spear points could cause injury to people or livestock.



Always shut off tractor and shift to “Park” or set brakes when leaving tractor. Always lower bucket or attachment to ground. Remove key when leaving tractor unattended.



Before operating equipment: If you have questions regarding the proper assembly or operation, contact your dealer or representative.



TRANSPORT SAFETY



Comply with state and local laws governing highway safety and movement of farm machinery on public roads.



The use of flashing amber lights is acceptable in most localities. However, some localities prohibit their use. Local laws should be checked for all highway lighting and marking requirements.



When driving the tractor and equipment on the road or highway under 20 mph (32 kph) at night or during the day, use flashing amber warning lights and a slow moving vehicle (SMV) identification emblem.



Always be sure the implement is in the proper raised position for transport.



Reduce speed when transporting mounted implements to avoid bouncing and momentary loss of steering control.



Make sure large round bales transported on tractor rear 3 pt. Hitch do not obstruct visibility of tractor’s flashing lights or SMV sign.



When transporting large round bales, keep load as low as practical to maximize tractor stability.



Transporting large round bales on front loaders can limit visibility. Keep load low and go slow if visibility is obstructed. Always use extra care.



Turn curves or go up or down hills only at a low speed and at a gradual steering angle. Make certain that at least 20% of the tractor’s weight is on the front wheels to maintain safe steerage. Slow down on rough or uneven surfaces, and loose gravel.



Use extreme care and maintain minimum ground speed when transporting on hillside, over rough ground and when operation close to ditches or fences. Be careful when turning sharp corners.



Never allow riders on either tractor or implement. Falling off can kill.

SAFETY INSTRUCTIONS (continued)



MAINTENANCE SAFETY



Keep all persons away from operator control area while performing adjustments, service, or maintenance.



Make sure there is plenty of ventilation. Never operate the engine of the towing vehicle in a closed building. The exhaust fumes may cause asphyxiation.



Before working on this machine, drive to a level area, disengage the PTO, lower implement (or if working underneath, raise an block securely), shut off the engine, set the brakes, and remove the ignition keys.



Never work under equipment unless it is blocked securely. Never depend on hydraulic system to keep implement in raised position.



Always use personal protection devices such as eye, hand and hearing protectors, when performing any service or maintenance.



Periodically tighten all bolts, nuts, and screws and check that all cotter pins are properly installed to ensure unit is in a safe condition.



When completing a maintenance or service function, make sure all safety shields and devices are installed before placing unit in service.



Never use your hands to locate a hydraulic leak on attachments. Use a small piece of cardboard or wood. Hydraulic fluid escaping under pressure can penetrate the skin.



Openings in the skin and minor cuts are susceptible to infection from hydraulic fluid. If injured by escaping hydraulic fluid, see a doctor at once. Gangrene and death can result. Without immediate medical treatment, serious infection and reactions can occur.



Check to ensure all safety signs are installed and in good condition. (See safety sign section for location drawing).



Never replace hex bolts with less than grade five bolts unless otherwise specified, i.e. shear bolts. Refer to bolt torque chart for head identification marking.

SAFETY INSTRUCTIONS (continued)



MAINTENANCE SAFETY (continued)



When replacement parts are necessary for periodic maintenance and servicing, genuine factory replacement parts must be used to restore your equipment to original specifications. The manufacturer will not claim responsibility for use of unapproved parts and/or accessories and other damages as a result of their use.



If equipment has been altered in any way from original design, the manufacturer does not accept any liability for injury or warranty.



STORAGE SAFETY



Following operation or when unhooking, stop the tractor, set the brakes, disengage the PTO, shut off the engine and remove the ignition keys.



Store the unit in an area away from human activity. Do not permit children to play on or around the stored unit.



Do not park equipment where it will be exposed to livestock for long periods of time. Damage and livestock injury could result.



Make sure all parked machines are on a hard, level surface and engage all safety devices.



If blocking is used, make sure it is solid and secure before leaving area.

**ALWAYS OBEY ALL SAFETY RULES!
ALWAYS BE CAREFUL!**

SAFETY SIGNS



CAUTION

- Read and follow owner's manual before installing, operating, or performing maintenance on this loader. Observe safety recommendations in manual.
- Loader must have a lift capacity 1000 lb. Greater than the weight of bale to be handled.
- Do not lift or carry anyone on loader or in bucket or attachment.
- For operator safety, always keep bale in front of tractor hood. NEVER position bale back over operator.
- Add recommended wheel ballast or rear weight for stability. When handling loads on both ends of tractor, load rear first and unload last.
- Set wheels wide for increased stability.
- Never raise loader to extreme heights on steep inclines.
- Do not stand or work under raised loader.
- Stop engine, lower arms, relieve all hydraulic pressure, and lock brakes before leaving operator's seat.
- When handling round bales with fork type equipment, be sure bolt-in stabilizer spike is installed. Without spike, uncontrolled bale movement could occur.
- Failure to observe the above precautions could result in serious injury or death.

101026



WARNING

Always insert spears in bale – never under bale.
Failure to do this can allow bale roll back when loader is raised, causing serious injury or death.

101127

(BBSF-2535 ONLY)



WARNING

Don't tilt the bucket when it is above 8 feet. Keep tines level.

Tilting the bucket backwards when it is above 8 feet can allow the load to roll backward over the tractor and operator causing injury or death.

101007

(T-1500 ONLY)

NOTICE
1500 LB.
CAPACITY

101150

NOTICE
1800 LB.
CAPACITY

101112

NOTICE
2800 LB.
CAPACITY

101150

Replace
Safety Decals
if damaged or missing.

INSTRUCTIONS

INTRODUCTION

The clamp-on loader bucket attachments provide a means of leaving the bucket on your tractor loader and easily converting the loader to handle large, round bales.

The attachments are easily installed or removed from your front loader in minutes. A chain and turnbuckle provide a secure, easy means of clamping the attachment to your loader bucket.



On double spear model BBSF-2535, always insert spears into the bale – NEVER under the bale. Failure to insert spears into bale can allow bale to roll back when loader is raised, causing serious injury or death.



Clamp-on bucket attachments hold the load in front of the loader bucket. The loader must have a lift capacity 1000 lbs. Greater than the weight of the bale to be handled. If the loader does NOT have this capacity, then an attachment that requires the removal of the bucket should be considered.

NOTE: The maximum load for the attachments is as follows:

BBS-1560	1500 lbs.
BBSF- 1565	1800 lbs.
BBSF- 2535	2800 lbs.
T-1500	1500 lbs.

TRACTOR AND LOADER REQUIREMENTS AND PREPARATION



The use of any loader attachment is NOT recommended on tractors with a tricycle wheel arrangement. Tricycle type tractors are unstable for front loader use.



It is recommended that tractors be equipped with a rollover protective structure (ROPS) or cab.

The required size of the tractor and front loader will be determined by the size and weight of the bales to be handled.

Remember, high moisture hay (silage) bales are very heavy in relation to similar size dry hay bales.

Always use a tractor and front loader large enough to safely handle your bales.

Check your tractor and front loader to make sure they are in good working condition. Check all frame mounting bolts to make sure they are tight.

Loaders that attach to the tractor frame rails should have a cross-tie installed for stability.

Check the hydraulic system. Be sure the tractor hydraulic oil and filter have been serviced according to the tractor manufacturer's recommendations.



Be sure your tractor is in good condition. Read all the safety precautions and make sure all tractor operators are familiar with the safety rules of operation.



A heavy load can cause instability in driving a tractor. Make sure the front or rear of the tractor is properly counter-balanced with weights. Always drive slowly – especially around turns. An unstable tractor could steer badly and possibly tip over, causing injury or death.



Do not exceed the maximum recommended large round bale weight listed for each of the loader spear models. Damage to the equipment or serious personal injury could result.

ASSEMBLY

Check your loader to make sure it is in good working order.

Refer to the exploded parts views in this manual for proper orientation of the chain, bolt, and washer.

Install the chain on the clamp-on attachment with the ½" hex bolt and locknut provided. Make sure that the flange washer is next to the chain link to provide more support for the chain.

Install the turnbuckle on the bucket attachment with the pin and cotter pins. Check the turnbuckle to make sure that it operates easily. Spreading some grease on the threads will help insure that it will remain free and easy to use.

INSTRUCTIONS (continued)

ASSEMBLY (continued)

Slide the front cutting edge of your loader bucket under the lip of the bucket attachment.

Raise the loader slightly so that the bottom of clamp-on attachment is about three or four inches off the ground. Engage tractor-parking brake and shut off the engine.

Place some solid blocking under the bottom of the bale handling attachment for safety.

Install the chain around the loader bucket and into the keyhole slot on the upper end of the turnbuckle. Slide the chain through the keyhole slot until the chain around the bucket is fairly tight – then tighten by turning the turnbuckle body. Tighten the chain so that the loader attachment and chain are securely fastened to the loader bucket.

If necessary, loosen the turnbuckle and relocate the keyhole slotted end to another chain link and retighten the turnbuckle.

Turn the locknut on the turnbuckle up tight against the end of the turnbuckle barrel and tighten with a wrench.



DO NOT operate loader and attachment if it is not securely fastened to the loader bucket. If loose, the bale and attachment could come off the loader bucket creating a dangerous situation that could lead to personal injury or death.

OPERATION

Be sure tractor is properly counterbalanced with weights before attempting to lift any load with the Bale Spear or Forklift Attachment.

If you are handling bales with both the front-end loader and the 3 pt. Hitch on the tractor, always load the 3 pt. Attachment first and unload last.

Using the bucket tilt cylinders, adjust the angle of the spear(s) so they are parallel with the center of the hay bale.

With the tractor, push the spear(s) into the large hay bale. Make sure you have penetrated the hay bale far enough so the bale doesn't want to come off the end of the spear(s). If, when you initially pick the bale up, it tends to droop forward, this indicates you have not penetrated the bale far enough.

Tilt the ends of the spear(s) upward (about 15-20 degrees) when transporting the hay bales. This will reduce any tendency for the bale to slide off the spear(s) while being transported.

When you have placed the hay bale in the desired location, it is recommended to tilt the spear ends slightly downward (5-7 degrees) so as you pull away from the bale

it will slide off the spear(s) more easily. Different location and circumstances will determine the best withdraw angle to use.

NOTE: Always make sure bale spear fully penetrates the bale. Partial penetration locates all the weight of the bale on the outer end and can damage spear. Not covered under warranty.

NOTE: In cold weather, a bale frozen to the ground may exceed the lifting capacity of spear and loader. Damage to spear or loader may occur. Not covered under warranty.

NOTE: Soft center bales will tend to droop after being lifted by a single spear. Placing the spear in a lower position in the bale will allow for more lifting height and lessen the load on the stabilizer spears.



Be sure stabilizer spike is in place when handling round bales with fork-type equipment. Without spike, uncontrolled bale movement could occur.



Never exceed the lift capacity of the tractor-loader used with the spear or forklift attachment.

LOADER FORKS

ADJUST TINE WIDTH – T-1500 FORKS ONLY

Raise loader bucket slightly (about 10-12 inches) and loosen the turnbuckles. Slide the individual forks to the correct width for the bales or load to be handled.

When correct width setting is obtained, tighten turnbuckles securely.

IMPORTANT: Use forklift tines adjusted to maximum width possible to increase load stability.



Beware of low electrical wires when loader is raised. Serious injury or death can result if contact is made.

When stacking bales, ALWAYS MAKE SURE BALES ARE PLACED SO THE STACK IS STABLE.

Keep all bystanders at a safe distance. REMEMBER FALLING BALES CAN ROLL OR TUMBLE.

INSTRUCTIONS (continued)

OPERATION (continued)

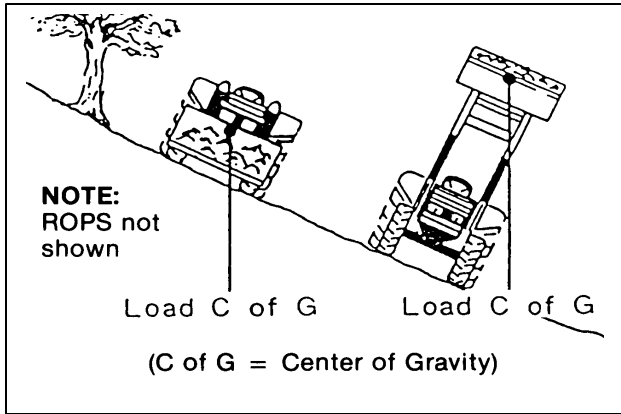

When working on side hills, **DO NOT RAISE LOADER TOO HIGH.** Keep an eye on terrain changes. Keep load low.



CAUTION



NEVER LET ANYONE CLIMB ON STACKED ROUND HAY BALES.



CAUTION



For operator safety, always keep bales in front of tractor hood. NEVER position bale back over operator. ALWAYS BE CAREFUL!

When stacking hay bales or loading vehicles, make sure you are operating in an area **AWAY FROM OVERHEAD WIRES.**

MAINTENANCE

Check the pins at the ends of the loader arms. Make sure they are locked in place with the linchpins or cotter pins.

Periodically check all bolts to make sure they are tight.

Check the large nut on the forged spears to make sure it is tight.

Lubricate loader as per instructions in loader manual.

Check chain links for wear – replace chain if necessary.

Replace safety signs and instruction decals if damaged or missing.

**REPLACE SAFETY SIGNS
IF DAMAGED OR MISSING.**

STORING SAFELY

- Never store equipment with fuel in the tank inside a building where fumes may reach an open flame or spark. Allow engine to cool before storing in an enclosure
- Always store blade in a clean, dry location away from children and livestock.
- Storage location should be level and solid to make hitching and unhitching easy.



**SAFETY....
YOU CAN LIVE WITH IT!**

- ✓ Keep children away from danger all day, every day.
- ✓ Equip tractors with roll-over protection (ROPS) and keep all machinery guards in place.
- ✓ Please work, drive, play, and live each day with care and concern for your safety and that of your family and fellow citizens.

REF NO.	PART NO.	DESCRIPTION	NO. REQ.
1	831221	Bale Spear Weldment	1
2	830406	Chain, 5/16" Proof Coil x 5 Ft.	1
3	2503265	Bolt 1/2"-13NC x 1 3/4" Hex Head Gr. 5	1
4	2501003	Washer 1/2" Flat	1
5	2500039	Nut 1/2"-13NC Nylock Hex	1
	831215	Complete Turnbuckle Assembly (#6 thru #10)	1
6	590277	Barrel	1
7	830412	Threaded Stub, LH	1
8	830410	Threaded Stub, RH	1
9	2500024	Nut 1"-8NC Jam Hex	1
10	590145	Handle	1
11	831229	Pin, Turnbuckle	1
12	2504121	Cotter Pin 3/16" x 1 1/2"	2
13	101026	Safety Sign-Caution (Instructions)	1
14	101040	Safety Sign-Notice (1500 Lb. Capacity)	1

BBS-1560 PARTS LIST

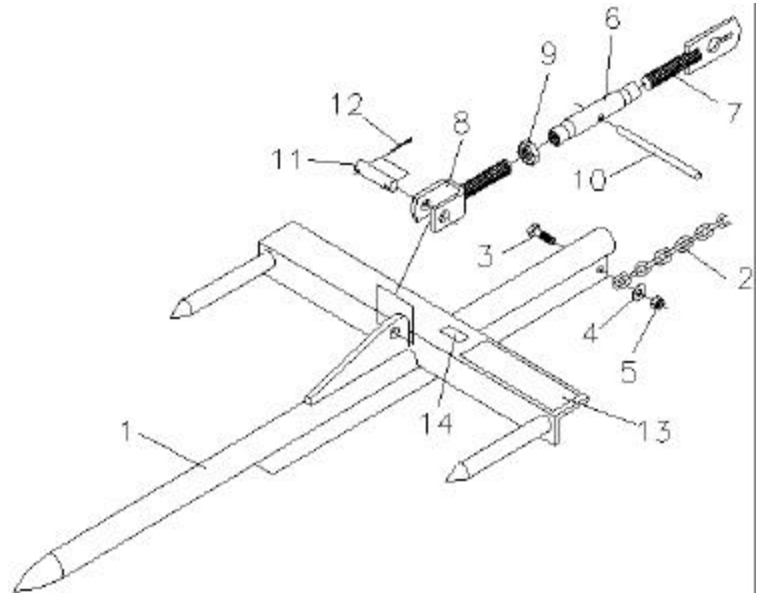

REF NO.	PART NO.	DESCRIPTION	NO. REQ.
1	830391	Main Frame Weldment	1
2	830406	Chain, 5/16" Proof Coil x 5 Ft.	1
3	2503265	Bolt 1/2"-13NC x 1 3/4" Hex Head Gr. 5	1
4	2501003	Washer 1/2" Flat	1
5	2500039	Nut 1/2"-13NC Nylock Hex	1
	831215	Complete Turnbuckle Assembly (#6 thru #10)	1
6	590277	Barrel	1
7	830412	Threaded Stub, LH	1
8	830410	Threaded Stub, RH	1
9	2500024	Nut 1"-8NC Jam Hex	1
10	590145	Handle	1
11	831229	Pin, Turnbuckle	1
12	2504121	Cotter Pin 3/16" x 1 1/2"	2
13	831273	Tine, Hay 49.2" (SHW)	1
14	831274	Nut, M28 Tine	1
15	101026	Safety Sign-Caution (Instructions)	1
16	101112	Safety Sign-Notice (1800 Lb. Capacity)	1

BBSF-1565 PARTS LIST

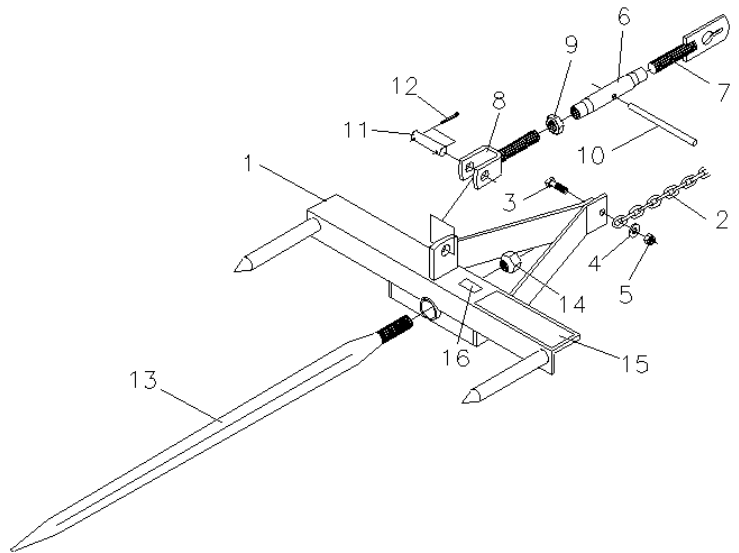

REF NO.	PART NO.	DESCRIPTION	NO. REQ.
1	830481	Main Frame Weldment	1
2	830406	Chain, 5/16" Proof Coil x 5 Ft.	2
3	2503265	Bolt 1/2"-13NC x 1 3/4" Hex Head Gr. 5	2
4	2501003	Washer 1/2" Flat	2
5	2500039	Nut 1/2"-13NC Nylock Hex	2
	831215	Complete Turnbuckle Assembly (#6 thru #10)	2
6	590277	Barrel	2
7	830412	Threaded Stub, LH	2
8	830410	Threaded Stub, RH	2
9	2500024	Nut 1"-8NC Jam Hex	2
10	590145	Handle	2
11	831229	Pin, Turnbuckle	2
12	2504121	Cotter Pin 3/16" x 1 1/2"	4
13	831273	Tine, Hay 49.2" (SHW)	2
14	831274	Nut, M28 Tine	2
15	101026	Safety Sign-Caution (Instructions)	1
16	101151	Safety Sign-Notice (2800 Lb. Capacity)	1
17	101127	Safety Sign-Warning (Insert Spears)	1

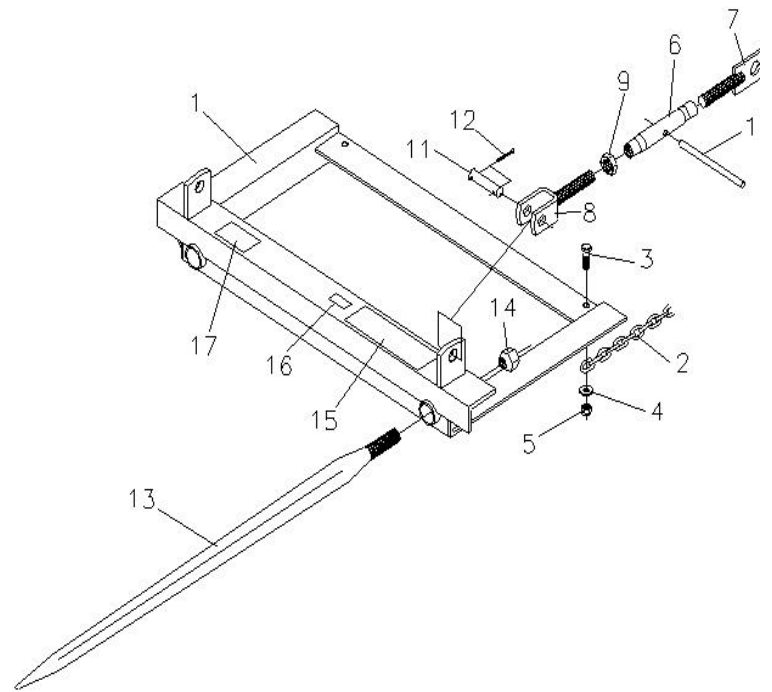

BBSF-2535 PARTS LIST

REF NO.	PART NO.	DESCRIPTION	NO. REQ.
1	830401	Tine Weldment	2
2	830406	Chain 5/16" Proof Coil x 5 Ft.	2
3	2503265	Bolt 1/2"-13NC x 1 3/4" Hex Head Gr. 5	2
4	2501003	Washer 1/2" Flat	2
5	2500039	Nut 1/2"- 13NC Hex Nylock	2
	831215	Complete Turnbuckle Assembly (#6 thru #10)	2
6	590277	Barrel	2
7	830412	Threaded Stub, LH	2
8	830410	Threaded Stub, RH	2
9	2500024	Nut 1"- 8NC Jam Hex	2
10	590145	Handle	2
11	830416	Pin, Turnbuckle	2
12	590034	Linch Pin 1/4" (AK-61)	4
13	830213	Balance Spike	2
14	830419	Mast Weldment	2
15	2503112	Bolt 1/2"- 13NC x 5" Hex Head	4
16	2502002	Washer 1/2" Springlock	4
17	2500003	Nut 1/2"- 13NC Full Hex	4
18	2503111	Bolt 5/16"-18NC x 1 3/4" Hex Head	2
19	2502011	Washer 5/16" Springlock	2
20	2500011	Nut 5/16"- 18NC Full Hex	2
21	101026	Safety Sign-Caution (Instructions)	1
22	101034	Safety Sign-Caution (Hay Equipment)	1
23	101040	Safety Sign-Notice (1500lb. Capacity)	1
24	101007	Safety Sign-Warning (Bucket Spikes)	1

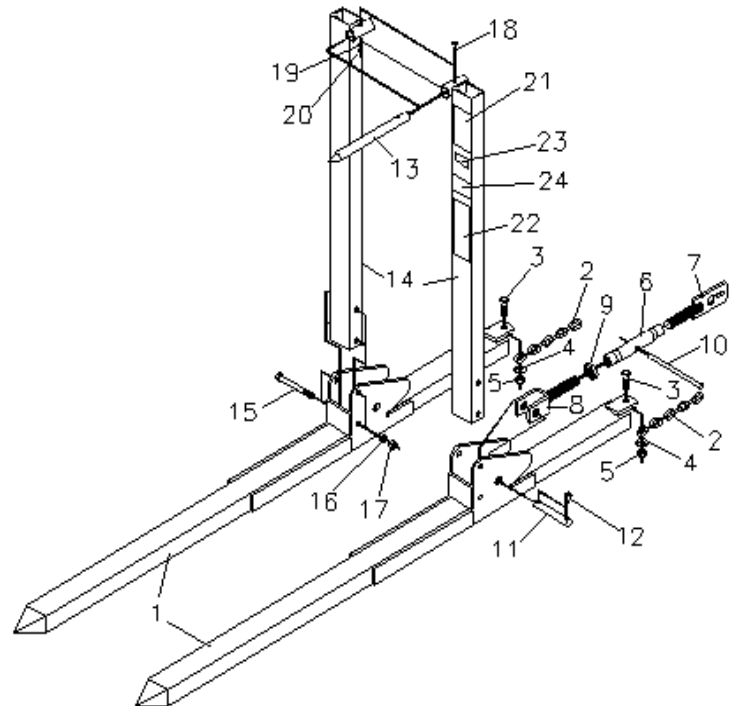

T-1500 PARTS LIST



SAFETY PRECAUTIONS

MOST ACCIDENTS OCCUR BECAUSE OF NEGLIGENCE OR CARELESSNESS, AVOID NEEDLESS ACCIDENTS BY FOLLOWING ALL OF THE SAFETY PRECAUTIONS LISTED BELOW.

- Machinery should be operated only by those who are responsible and are authorized to do so.
- Stop the engine, lower all equipment, lock the brakes, and remove the ignition key before dismounting from the tractor.
- Never stand between tractor and implement while tractor is being backed to hitch.
- Loose fitting clothing should not be worn, to avoid catching on various parts.
- Detach implement in area where children normally do not play.
- When performing adjustments or maintenance on an implement, first lower it to the ground or block it securely at a workable height.
- Only a qualified operator should be permitted on tractor when in operation; no riders allowed.
- Make certain everyone is in the clear before starting tractor or raising or lowering equipment.
- Operate the tractor and implement only while seated in the driver's seat.
- Reduce speed when transporting mounted implement to avoid bouncing and momentary loss of steering control.
- A heavy load can cause instability of the tractor. Use extreme care during road travel. Slow down on turns and watch out for bumps. Tractor may need front counter-weights to counter-balance the weight of the implement.
- Reduce speed on hillsides or curves so there is no danger of tipping.
- Avoid driving too close to the edge of ditches or creeks.
- Do not transport implement on public toads without reflectors and slow moving vehicle emblem in daylight and with approved warning lights at night and other periods of poor visibility.
- Due to the width of some implements, use extra caution on highways, farm roads, and when approaching gates.
- Always be sure the implement is in the proper position for transport.
- Keep alert and watch the front as well as the rear when working with the implement.

OWNER'S MANUAL

MODEL NO.'s
BBS-1560
BBSF-1565
BBSF-2535
T-1500

WHEN ORDERING
 REPAIR PARTS, ALWAYS
 GIVE THE FOLLOWING
 INFORMATION:

1. PART NUMBER
2. PART DESCRIPTION
3. MODEL NUMBER
4. NAME OF ITEM

MARCH 2001

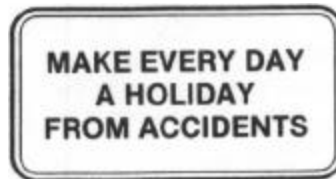

LOADER BUCKET ATTACHMENT(S) (CLAMP-ON)

FARM STAR LIMITED WARRANTY

Farm Star warrants its implements, parts and accessories to be free from defects in materials and workmanship for a period of six (6) months from the date of purchase. Upon written approval, **Farm Star** will repair or exchange without charge any part, which upon examination by **Farm Star** or its authorized agent, shall disclose to be defective.

This does not apply to (1) parts that have worn out in normal use, (2) parts broken because of improper assembly or operation by the customer, (3) parts accidentally damaged, (4) failure of parts traceable to improper care, (5) parts failing through use of implement for purposes other than those for which it was designed.

The obligations assumed by **Farm Star** and the limitations expressed herein are in lieu of all other warranties expressed or implied.

FARM STAR

P.O. BOX 1000, LITCHFIELD, IL. 62056-0100

Phone: 1-217-324-5973 Fax: 1-217-324-3356

Web Site: www.farmstar.com