

**SWLSHER**

# OWNER'S MANUAL

STARTING SERIAL #:  
L103-335001

## MODEL NO.

**FT1150**



**IMPORTANT**  
Read and follow all  
Safety Precautions  
and Instructions  
before operating this  
equipment.

Rev. 05-193

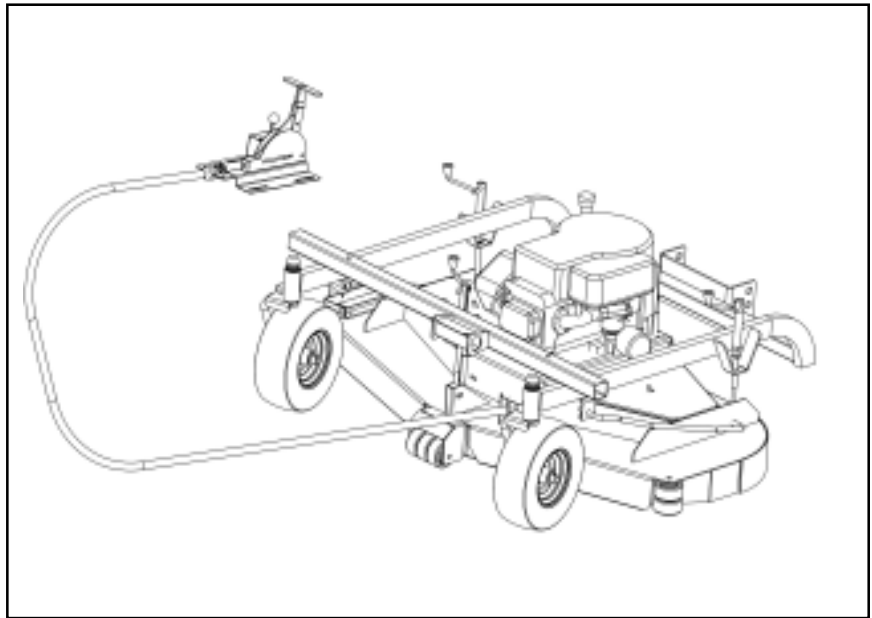

## 50" UNIVERSAL MOUNT TRAILMOWER®

For Vehicle Mounting Options See  
Details On Page-16

**Assembly  
Operation  
Service and Adjustment  
Repair Parts**

**SWLSHER**

1602 CORPORATE DRIVE, P.O. BOX 67, WARRENSBURG, MISSOURI 64093  
PHONE 660-747-8183 FAX 660-747-8650

**Manufacturing quality lawn care equipment since 1945**

*Made In The*

**USA**

## SAFETY PRECAUTIONS



**This Safety Alert Symbol indicates important messages in this manual. When you see this symbol, carefully read the message that follows and be alert to the possibility of personal injury.**

**Read this manual completely. This machine can amputate hands, feet, and throw objects. Failure to observe the following safety instructions could result in serious injury or death.**

- Read the manual. Learn to operate this machine safely.
- Always disconnect the spark plug wire and place the wire where it cannot contact the spark plug, to prevent accidental starting the engine when setting up, transporting, adjusting or making repairs.
- Keep all shields and guards in place.
- Understand the speed, steering and stability of this machine. Know the positions and operations of all controls before you operate this machine. Check all of the controls in a safe area before starting to work with this machine.
- Allow only responsible adults who are familiar with these instructions to operate this machine. Never allow children to operate this machine.
- Clear the area of objects such as rocks, toys, wire, etc. that can be picked up and thrown by the blade.
- Be sure the area is clear of other people before mowing. Be aware of the mower discharge direction and do not point at anyone. Stop the machine if anyone enters the mowing area. Children are often attracted to the machine and the mowing activity. ***Never assume that children will remain where you last saw them.*** Keep children under the watchful care of another responsible adult.
- **No riders on this unit at any time.!**
- Do not put hands or feet near or under rotating parts. Keep clear of the discharge opening at all times.
- Do not mow in reverse. Always look down and behind before and while backing.

- Turn off the blades when not mowing. Before leaving the machine, turn off the blades and stop the engine.
- Watch for traffic when operating near or crossing roadways.
- Do not operate the mower if it has been dropped or damaged in any manner or if the mower vibrates excessively. Excessive vibration is an indication of damage. Repair mower as necessary.
- Dress properly. Do not operate the mower when barefoot or wearing open sandals. Wear only solid shoes with good traction when mowing.
- Do not operate the machine while under the influence of alcohol or drugs.
- Operate self-propelled machines up and down slopes. There is significant risk of overturns when operating across slopes. Operate walk-behind machines across slopes. There is a significant risk of slipping under a walk-behind machine when operating up and down slopes.
- Never tamper with safety devices. Check their proper operation regularly.
- Stop and inspect the equipment if you strike an object. Repair, if necessary, before restarting.
- Never make adjustments or repairs with the engine running.
- Mower blades are sharp and can cut. Wrap the blades or wear gloves, and use extra caution when servicing them.

### **? Did You Know ?**



Swisher Mower & Machine Co. was started in 1945.

# MOWER MAINTENANCE

## GENERAL RECOMMENDATIONS

The warranty on this trailmower does not cover items that have been subjected to operator abuse or negligence. To receive full value from the warranty, operator must maintain unit as instructed in this manual.

Some adjustments will need to be made periodically to maintain your unit properly.

All adjustments in this manual should be checked at least once each season.

## BEFORE EACH USE

- Check engine oil level on a level surface. (Check twice to insure an accurate reading.)
- Check condition of air filter; clean and replace as necessary.
- Check blade operation; keep blades in good condition.
- Check for loose fasteners and tighten them as needed.

## AFTER EACH USE

- Keep blades sharp.
- Remove fresh grass clippings with garden hose.
- Hardened grass clippings on underside should be scraped out with a putty knife.
- Keep fluids at proper levels.
- Cover unit to prevent rain or other debris build-up. Definitely cover the engine.

## BEFORE AND/OR AFTER EACH SEASON

- Replace the spark plug.
- Clean or replace the air filter.
- A new spark plug and clean air filter assure proper air-fuel mixture and help your engine run better and last longer.
- Check blades and belts for wear. Replace as necessary.

## STORAGE RECOMMENDATIONS

**⚠ CAUTION!** Do not store engine indoors or other poorly ventilated area. Keep engine away from gas appliances where fumes could contact open flame, pilot lights, or sparks.

**⚠ If engine is to be stored for 30 or more days, prepare unit as follows:**

- Drain fuel outside into an approved container.
- Start engine properly and run until unit is out of fuel.
- Let engine cool.
- Remove remaining gasoline from carburetor and fuel tank to prevent gum deposits from forming within the engine. Gum deposits can cause malfunction in the engine.
- Store mower with blades disengaged to prevent belts from being permanently stretched.

## BLADE CARE AND SERVICE

For best results cutter blades must be kept sharp. The blades can be sharpened with a few strokes of a file or grinding wheel. Do not attempt to sharpen blades while they are on the cutter. ***Disconnect spark plug wire before servicing unit.***

**Important:** Mower blades are sharp always wear gloves. [ see page 3 ]

**Important:** Replace blades that have been damaged or deeply nicked.

**Important:** Check blade and spindle hardware on a regular basis to make sure nuts are tight.



Only a qualified mechanic should conduct any adjustments, disassembly or other kind of repairs.

## LIMITED WARRANTY

The manufacturer's warranty to the original consumer purchaser is: This product is free from defects in materials and workmanship for a period of one (1) year from the date of purchase by the original consumer purchaser. We will repair or replace, at our discretion, parts found to be defective due to materials or workmanship. This warranty is subject to the following limitations and exclusions:

- 1) Engine Warranty                      All engines utilized on our products have a separate warranty extended to them by the individual engine manufacturer. Any engine service difficulty is the responsibility of the engine manufacturer and in no way is Swisher Mower Co., Inc. or its agents responsible for the engine warranty. The Briggs & Stratton Engine Service Hot-Line is 1-800-233-3723. The Tecumseh Engine Service Hot-Line is 1-800-558-5402.
  
- 2) Commercial Use                      The warranty period for any product used for commercial or rental is limited to ninety (90) days from the date of original purchase.
  
- 3) Limitations                              This warranty applies only to products which have been properly assembled, adjusted, and operated in accordance with the instructions contained within this manual. This warranty does not apply to any product of Swisher Mower Co., Inc., that has been subject to alteration, misuse, abuse, improper assembly or installation, shipping damage, or to normal wear of the product.
  
- 4) Exclusions                                Excluded from this warranty are normal wear, normal adjustments, and normal maintenance.

In the event you have a claim under this warranty, you must return the product to an authorized service dealer. All transportation charges, damage, or loss incurred during transportation of parts submitted for replacement or repair under this warranty shall be borne by the purchaser. Should you have any questions concerning this warranty, please contact us toll-free at 1-800-222-8183. The model number, serial number, date of purchase, and the name of the authorized Swisher dealer from whom you purchased the mower will be needed before any warranty claim can be processed.

THIS WARRANTY DOES NOT APPLY TO ANY INCIDENTAL OR CONSEQUENTIAL DAMAGES AND ANY IMPLIED WARRANTIES ARE LIMITED TO THE SAME TIME PERIODS STATED HEREIN FOR ALL EXPRESSED WARRANTIES. Some states do not allow the limitation of consequential damages or limitations on how long an implied warranty may last, so the above limitations or exclusions may not apply to you. This warranty gives you specific legal rights and you may have other rights, which vary from state-to-state. This is a limited warranty as defined by the Magnuson-Moss Act of 1975.

## OPERATING YOUR MOWER



The operation of any mower can produce foreign objects to be thrown into the eyes, resulting in severe eye damage. Always wear certified safety glasses or wide-vision safety goggles over spectacles before starting any cutting machine and while operating such a machine.



The operation of any cutter produces sound waves that are damaging to the human ear. Ear protection is recommended.



### **CAUTION!**

Tragic accidents can occur if the operator is not alert to the presence of children. Children are often attracted to the machine and the mowing activity. *Never assume that children will remain where you last saw them.*

### **INTENDED USE**

This trail mower is designed to produce a quality finish cut on lawns, golf courses, etc. It is not designed to clear brush or cut saplings. Your mower should be pushed in front of or be towed behind an ATV, a golf cart, lawn tractor, or another similar approved vehicle. It is not meant for speeds exceeding 5 MPH. Your mower should be kept clean and worn parts replaced promptly and properly. **WARNING:** To avoid serious injury, operate your mower up and down the face of slopes, NEVER across the face. **DO NOT MOW SLOPES GREATER THAN 15 DEGREES!** (SEE DIAGRAM ON PAGE 15 )

### **FRONT MOUNTING MOWER TO VEHICLE—[figure 9 page-16]**

- Securely attach Mount Kit to vehicle. [ As shown in kit mounting instructions ]
- Park vehicle at rear of mower.
- Casters should be able to rotate freely 360 degrees
- Using clips and washers attach mower to vehicle.
- Fix console assembly securely to vehicle using enclosed Velcro strips with adhesive.
- Fix wire harness tubing to hitches using Velcro straps.

## STARTING THE ENGINE

- See engine manufacturer's instructions for the type and amount of oil and fuel used. Engine must be level to accurately check and fill oil. **Do not overfill.**
- Park vehicle and mower on a level surface, set the vehicle parking brake, and disengage blades.
- Check spark plug wire, oil, and fuel.
- Check all electrical connections.
- Make certain console assembly is secured to vehicle.
- Set engine throttle control to the "CHOKE" position.
- Turn key switch to the "START" position
- Set engine throttle at desired RPM.

## STOPPING THE ENGINE

- Turn key switch to the "OFF" position.

## BREAKING IN YOUR MOWER

- Set vehicle parking brake or chock wheels to prevent accidental rolling.
- Start engine.
- Engage blades.
- In a safely monitored environment, i.e. no children, allow blades to rotate and engine to idle for 5 minutes. This breaks in the belts and the engine.
- Stop mower.



### CAUTION!

SHUT OFF MOWER ENGINE AND REMOVE SPARK PLUG WIRE FROM SPARK PLUG BEFORE MAKING ANY ADJUSTMENTS TO THE MOWER.

## MOWER HEIGHT ADJUSTMENT

- **Never make any adjustments while mower is running.**
- The cutting range is approximately 1.5" to 4.5". The height has been measured from the ground to the blade tip without the engine running.
- Rotate height adjust crank handles in a clockwise direction to lift the mower deck. A counter-clockwise direction is used to lower the mower deck.
- Make sure the height adjustment is the same at side crank handles. For best results, see "SUGGESTED MOWING PRACTICE" section. **Graduated scales are for reference only, not the actual cutter height.**
- Place crank handle in a retracted position to maintain height adjustment.

## START MOWING

- Clear mowing area of debris.
- Check vehicle to mower connection.
- Start mower engine.
- Engage clutch lever.
- Begin mowing slowly.

## **STOP MOWING**

- Bring vehicle to a full stop.
- Disengage clutch lever by moving lever to center position.
- Turn key switch to “OFF” position.

## **TRANSPORTING MOWER**

- **Never transport unit with engine running.**
- If transporting unattached from tow vehicle, remove spark plug wire and place it where contact with the spark plug cannot be made.

## **SUGGESTED MOWING PRACTICES**

- Operate mower engine at full throttle to assure the best cutting performance and maximum material discharge.
- Allow wet grass to dry. Clumps of wet grass will collect under the mowing deck.
- Mowing should be started with tow vehicle in low gear and increased only as safe mowing conditions permit. This speed should not exceed 5 MPH.
- The average lawn should be cut to approximately 2.5” during the cool season and to over 3” during the hot months.
- For a healthier lawn and better aesthetics, your lawn should be mowed often and after moderate growth.
- When cutting high or dense grass areas go slowly. Some areas may need to be cut twice. The second cut should be at 90 degrees to the first, if possible.
- Never remove more than 1/3 of the grass length at any one time

## **GENERAL TROUBLE SHOOTING**

- The mower does not cut level.
  - Level deck, making sure height adjustments are equal.
  - Check air pressure of all tires; make sure they are equal (about 25-30 psi).
  - Check blade attachment.
- The engine will not start.
  - Disengage blades, turn switch to “OFF” position, check all electrical connections, and inspect spark plug and wire.
- Engine runs poorly.
  - See engine manual.
  - Check throttle adjuster.
  - Replace fuel, clean fuel filter and fuel line.



IF PROBLEMS PERSIST HAVE A QUALIFIED MECHANIC SERVICE THE MOWER. NEVER ATTEMPT TO MAKE AN ADJUSTMENT THAT YOU ARE NOT SURE IS CORRECT. DOING SO CAN CAUSE OTHER PROBLEMS.

# SAFETY AND OPERATIONAL DECALS

Replace decal immediately if damaged. Order by part number from Swisher Mower and Machine Co. Inc.



OD45 – Warning Decal



OD15-Important Decal



Decal located On grass chute [not shown]



OD33 – Speed Decal

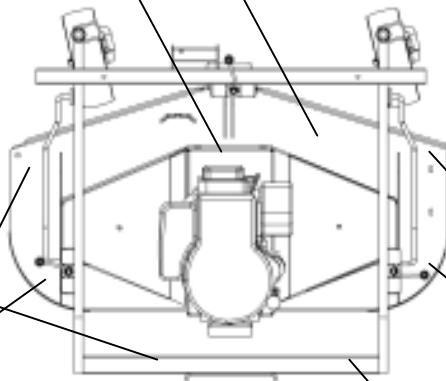

OD55 – Triangle Danger Decal

OD10--BLADE ENGAGE DECAL



OD99- ON / OFF DECAL

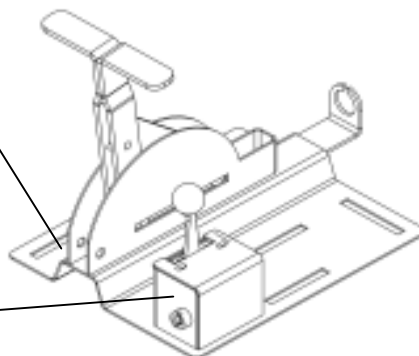
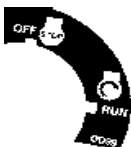

OD11- NO STEP DECAL

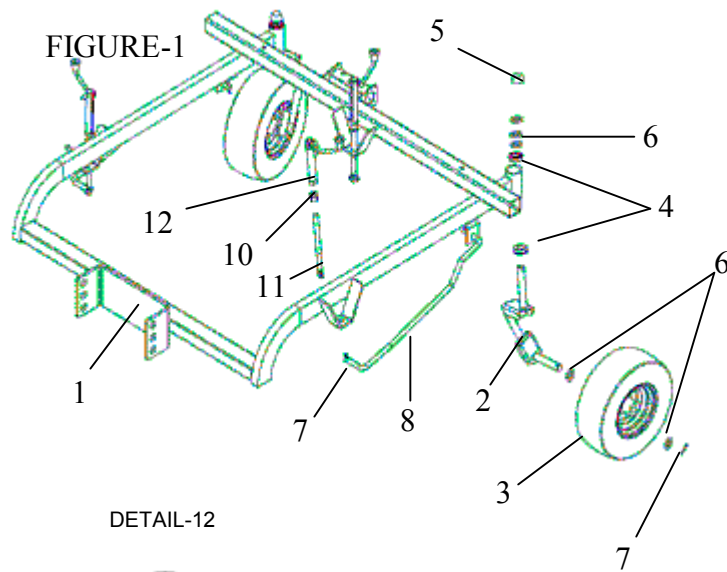

**SEE DETAIL  
BELOW- # 12**

**FRAME ASSEMBLY** FIGURE 1

Item No.	Description	Part #
1	Frame Weldment	5147TK
2	Caster Weldment	5072
3	Tire & Wheel NO Tread 4.10x3.5-5	5057
4	Bearing, Flanged 3/4 ID	CB58
5	3/4 Push Nut BLK Plastic	NB-687
6	3/4ID X 1 1/4OD 10 GA. Washer	NB-195
7	1/8 X 1 Cotter Pin	NB-126
8	Sway Bar Right	3664
9	Sway Bar Left	3665
10	Stepped Hgt. Adj. Bushing	10579
11	1/2-13 X 7 3/4 Eye Bolt	10038
12	<b>Height Adj. Assembly</b>	<b>H7NTK</b>
13	5/16 PAL NUT	NB276
14	KNOB	H7K
15	CRANK ROD	ES214
16	HEIGHT ADJ. TUBE	ES225

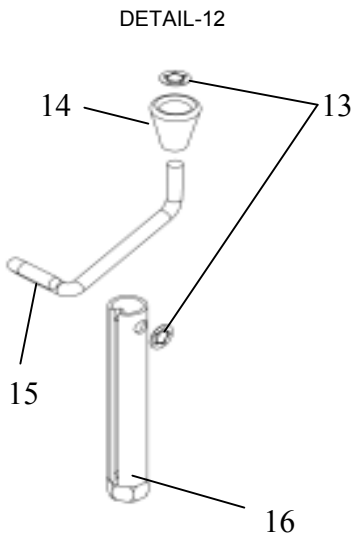

# 12



**? Did You Know ?**

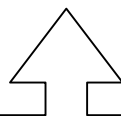

In 1956 Swisher Mower & Machine Co. introduced the first zero turning radius riding mower. The design of this 3-wheeled mower included safety features ahead of its time. In January 2000, it was named one of the century's top inventions by Popular Mechanics Magazine.

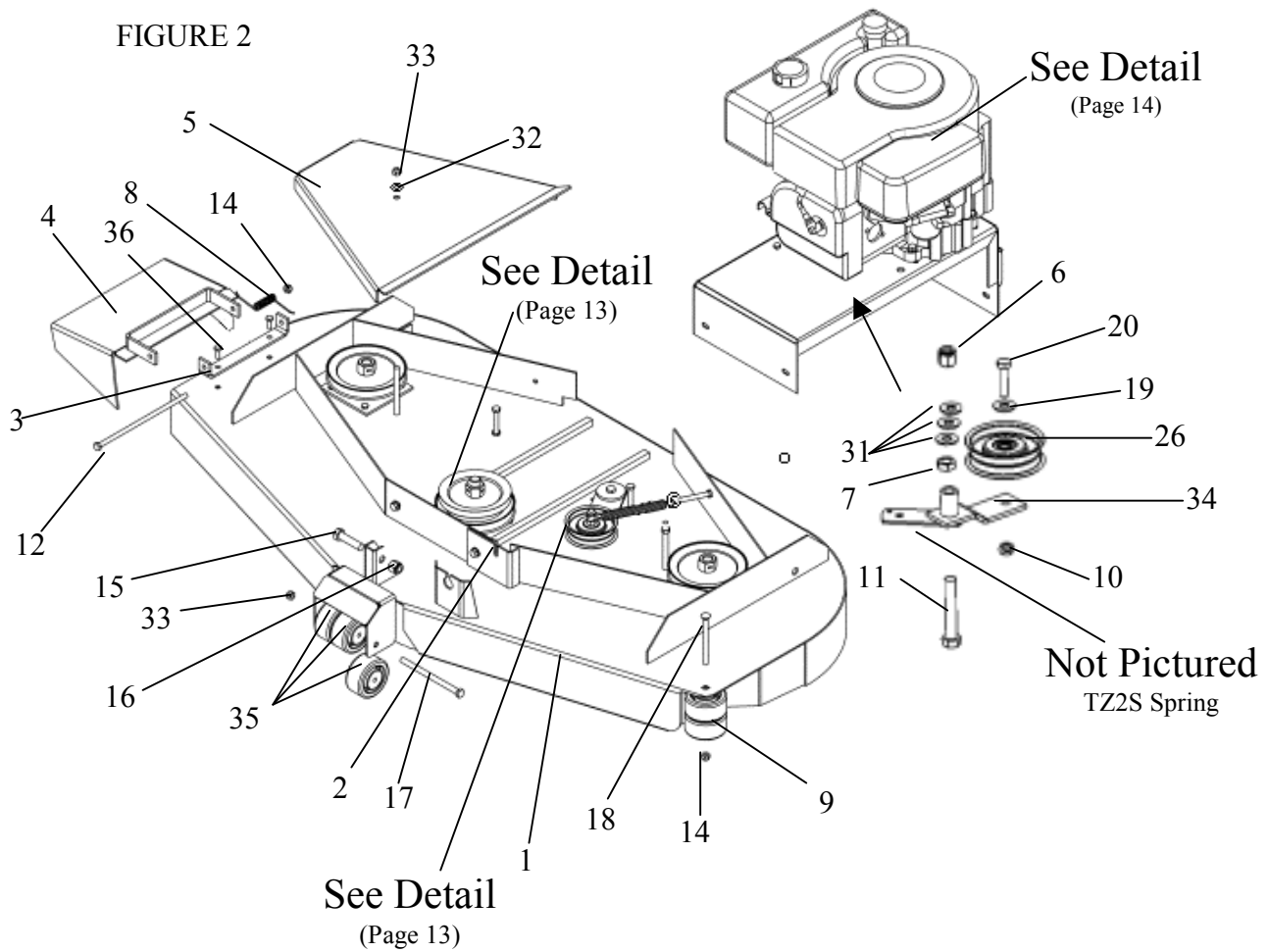

**DECK ASSEMBLY** FIGURE 2

Item #	Description	Part #	Item #	Description	Part #
1	50" Deck Weldment	5158TK	18	5/16-18 X 4 Carriage Bolt	NB-101
2	Engage Cable Mount	5095TK	19	3/8 SAE Washer	NB-272
3	Grass Chute Mount	6030TK	20	3/8-16 X 1 1/2 HCC GR5 Bolt	NB-107
4	Grass Chute Weldment	3773TK	26	Idler Pulley OD-3.25", ID-3/8"	B527
5	BELT COVER	5103TK	31	Washer	NB-177
6	1/2-13 Nyloc Nut	NB-281	32	Washer	NB-272
7	1/2-13 Hex Nut	NB-121	33	3/8-16 Nylok Nut Jam	NB-182
8	Chute Spring	9100	34	Engine Idler	5115TK
9	Anti-Scalp Roller	AS-001	35	Anti - Scalp Roller	AS-001
10	3/8-16 Lock Nut	NB-280	36	5/16 - 18 X 3/4" Bolt	NB596
11	1/2-13 X 3 HCC GR5 Bolt	NB-131			
12	5/16-18 X 8 1/2 HCC GR2 Bolt	NB-136			
14	5/16-18 Nyloc Nut	NB-181			
15	1/2-13 X 2 HCC GR5 ZP	NB-509			
16	1/2-13 Nyloc Nut	NB-281			
17	3/8-16 X 5 1/2 GR5 ZP	NB-575			

# Console Assembly Figure 7

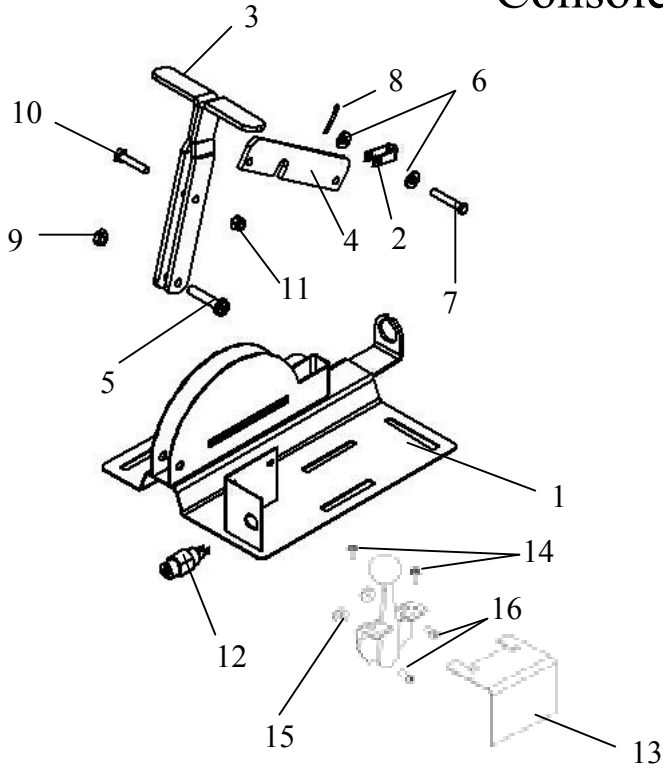

Item No.	Description	Part #
1	Console Weldment	5136TK
2	Clutch Cable Clevis	9023MOD
3	T Handle	4463TK
4	Link for Console	4461TK
5	5/16-18 X 1 1/2 Torx Pan ZP	NB-591
6	1/4 SAE Washer	NB-274
7	1/4 X 1 1/2 Clevis Pin	NB-518
8	3/32 X 3/4 Cotter Pin	NB-597
9	5/16-18 Jam Nut	NB-181
10	1/4-20 X 1 1/4 HCC GR5 ZP	NB-560
11	1/4-20 Nylok Nut	NB-180
12	Key Switch	KSM
Shown below	Wiring Harness	WHBP50
13	Throttle Cover [painted ]	5135TK
14	8 X3/8 Sheet Metal Screw	NB137
15	8-32 Kep Nut	NB201
16	8-32 x 1/2 Phil Truss	NB197

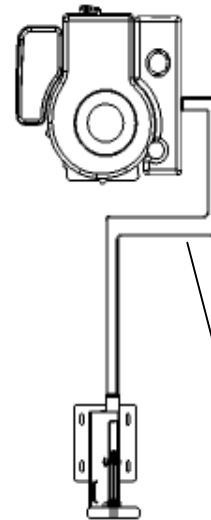

**WHBP50**  
(Complete Wiring  
Harness)

## BELT CONFIGURATION

Figure 5

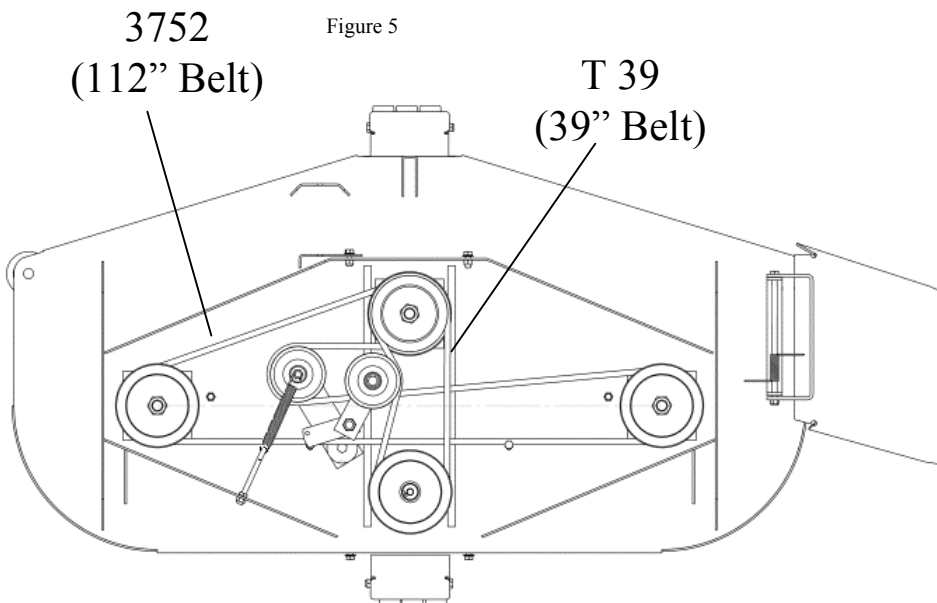

## BLADE DRIVER SET-UP

Figure 6

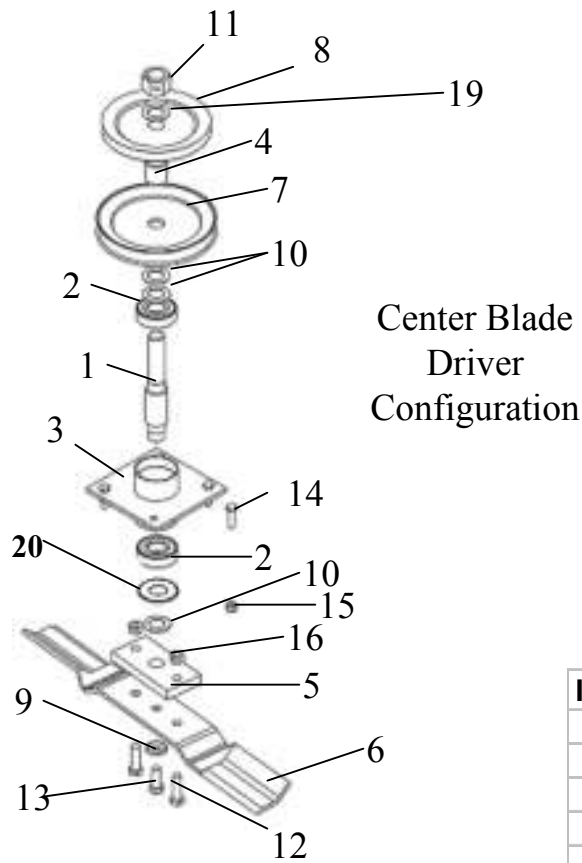

Center Blade  
Driver  
Configuration

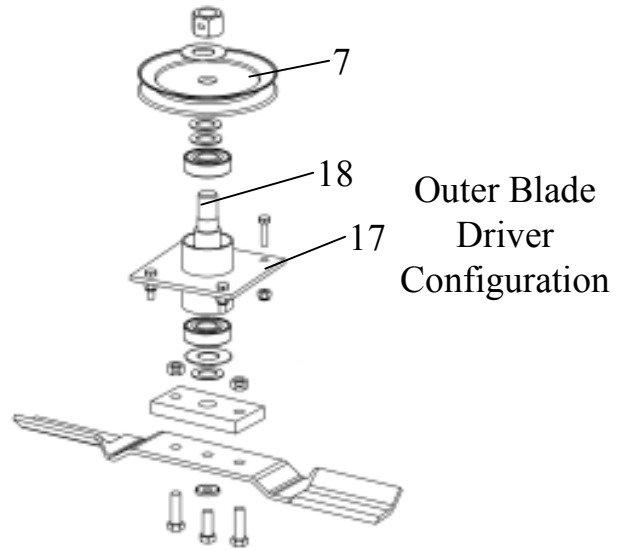

Outer Blade  
Driver  
Configuration

Blade Driver Assy.  
9058- 5.75" (Center Shaft)  
9018- 4.25" (Outer Shafts)

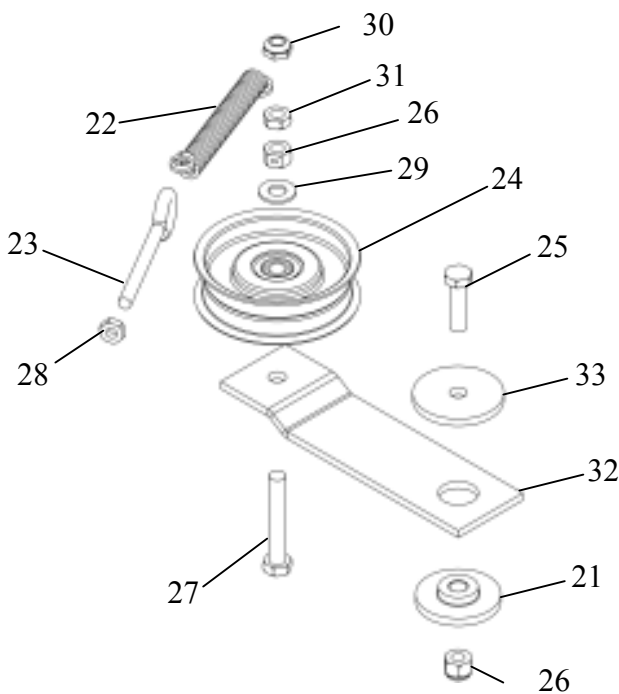

Item No.	Description	Part #
1	Center Shaft	9054
2	Blade Bearing	B98
3	Bearing Housing	9057TK
4	Pulley Spacer	6065PM
5	Blade Mount Plate	9008
6	17 1/2" Blade	5059
7	Blade Pulley- 5.5"	6114
8	Blade Pulley- 5"	3785
9	SP Washer Bellm. PLN .413 X .945 X .118	NB-607
10	3/4 ID X 1 1/4 OD 18 GA Washer	NB-179
11	3/4-16 Jam Nut	NB-175
12	3/8-24 X 1 Bolt	NB-238
13	3/8-24 X 1 Engine Bolt Locktite	NB-238N
14	1/4-20 X 3/4 HCC GR5 ZP	NB-250
15	1/4-20 Nylok Nut	NB-180
16	3/8-16 2-Way Lock Nut	NB-216
17	Housing Blade Bearing Short	B99EC
18	L&R Shaft	9076
19	BELLEVILLE WASHER	AS155
20	Washer	B98W

Item No.	Description	Part #
21	Idler Bushing	6037
22	Idler Tension Spring	TZ2S
23	5/16-18 X 3 1/2 Eye Bolt	NB315
24	Idler Pulley OD-3.25", ID-3/8"	B527
25	3/8-16 X 1 1/4 GR5 ZP	NB618
26	3/8-16 Nyloc Nut	NB280
27	3/8-16 X 2 1/4 HTC GR5 ZP	NB693
28	5/16-18 Serrated Flange Nut	NB170
29	3/8 SAE Washer	NB272
30	3/8-16 Nylok Nut Jam	NB207
31	3/8-16 Nut	NB174
32	Idler Arm	6041TK
33	Washer	6040

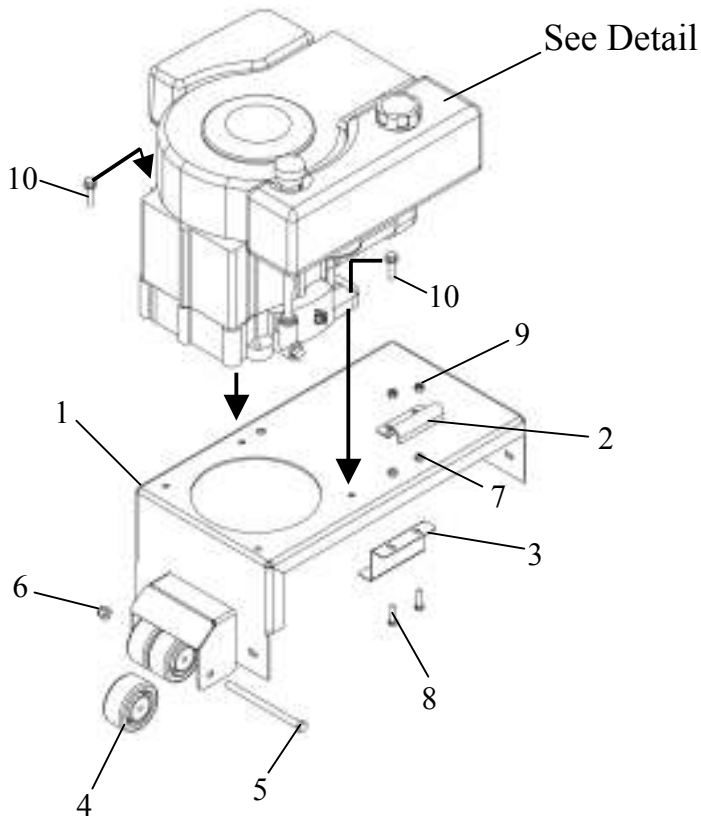

**MOTOR BASE ASSEMBLY** Figure 3

Item No.	Description	Part #
1	Motor Base	5102TK
2	Heat Shield	5094TK
3	Belt Guard	5097TK
4	Anti-Scalp Roller	AS-001
5	3/8-16 X 5 1/2 GR5 ZP	NB-575
6	3/8-16 Nyloc Nut	NB-182
7	1/4-20 HX NUT	NB-139
8	1/4-20 X 1	NB-102
9	1/4-20 Hx Nut ZP	NB-134
10	5/16-18 X 2 1/2 HCC GR5 ZP	NB-253
11	5/16-18 Serrated Flange Nut	NB-170

**ENGINE SET-UP** FIGURE 4

Item No.	Description	Part #
13	11- HP B&S Engine	N/A
14	3/8-24 X 1 Engine Bolt Locktite	NB-452N
15	Washer Belleville	699
16	1/4 X 1 Key Stock	9031
17	Engine Pulley- 5.5"	688
18	Engine Pulley Spacer Short	689S
19	Engine Pulley Spacer Long	689L
20	5/16-18 X 1-3/4 BOLT	NB515
21	5/16 SAE Washer	NB275
22	5/16-18 Flge. Nut	NB170
23	Belt Guide	6000
24	Washer	TR150W
25	5/16-18 Nyloc Nut	NB181

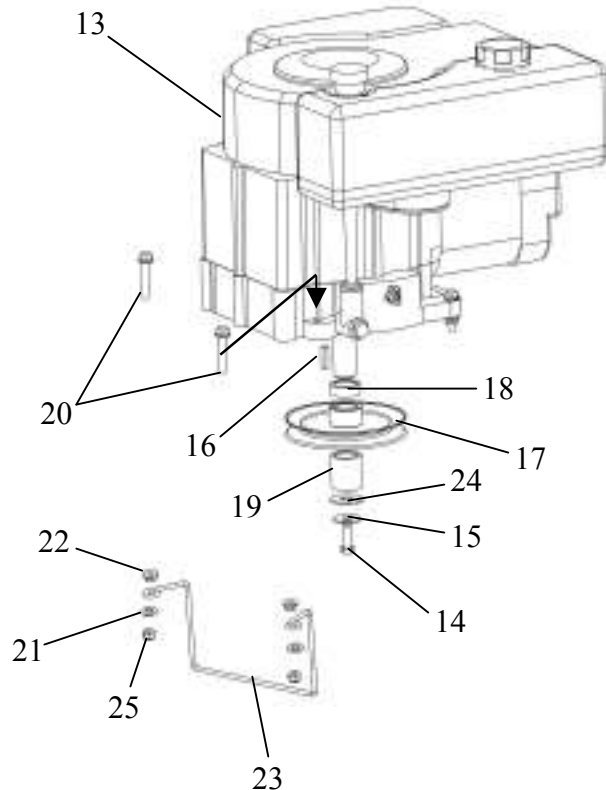

# SUGGESTED GUIDE FOR SIGHTING SLOPES FOR SAFE OPERATION

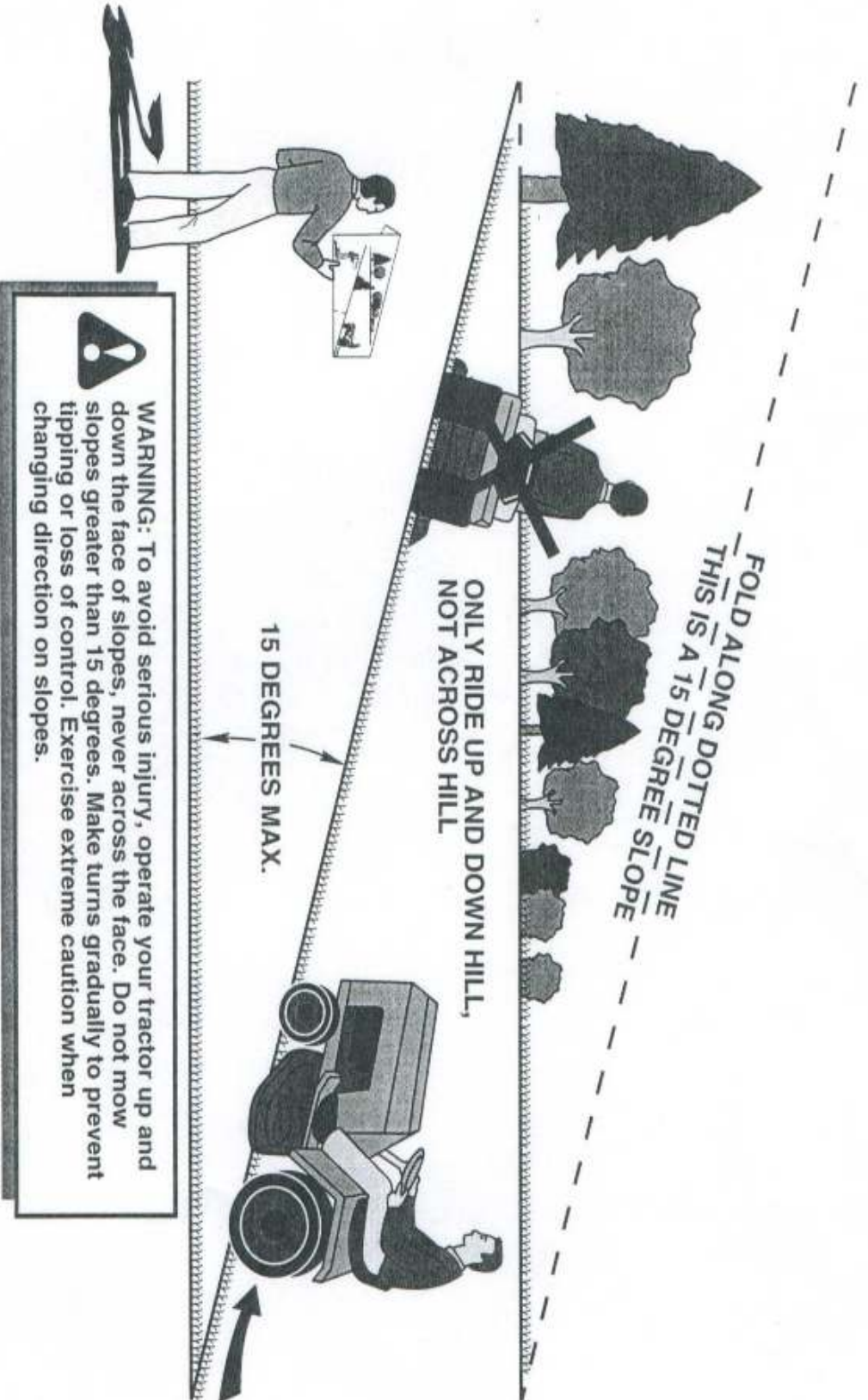

1. Fold this page along dotted line indicated above.
2. Hold page before you so that its left edge is vertically parallel to a tree trunk or other upright structure.
3. Sight across the fold in the direction of hill slope you want to measure.
4. Compare the angle of the fold with the slope of the hill.

FIGURE 9

## Attachment Options

- Attaching unit to operate in the front mount position

(Quick Switch™ Mount kit sold separately)

Detail-1 , 3

### Quick Switch™ Mount kit

Detail-1

PART# 2646

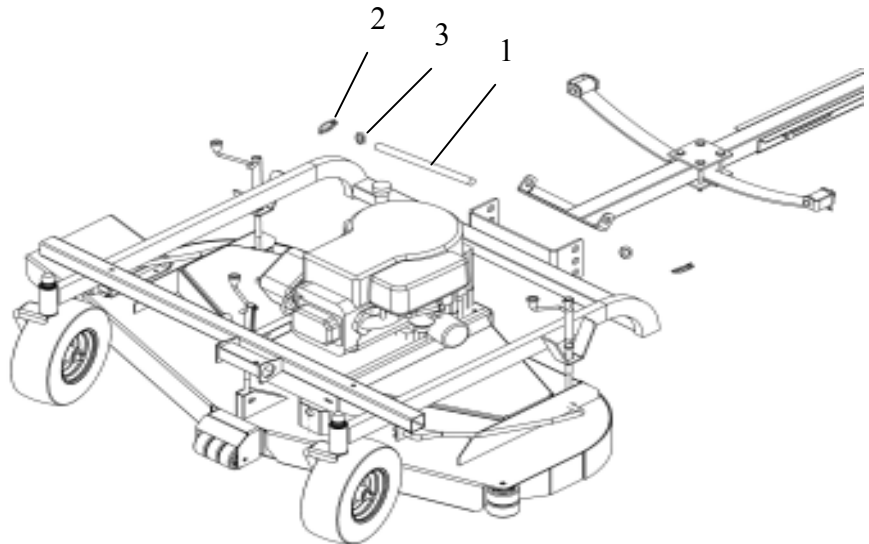

Item No.	Description	Part #
1	Mount Pin	5153TK
2	3/16 Click Pin	NB506
3	3/4 ID Washer	NB195

Detail-3

PART# 9146

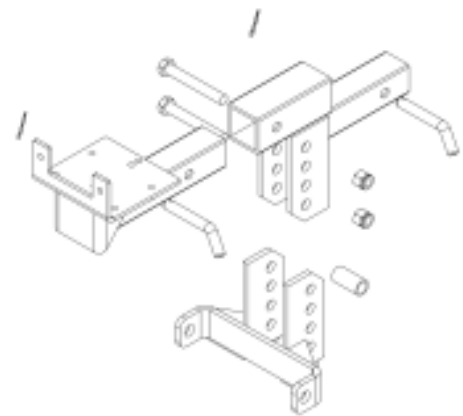

**REPAIR PARTS**

Your 50'' Trailmower® has been produced with components designed specific to this machine. Although standard V-belts, springs, bearings, blades, pulleys, hardware, etc. look similar to parts used on other machinery, they may in some cases be made of a different construction and/or materials.

---

---

---

---

---

---

---

---

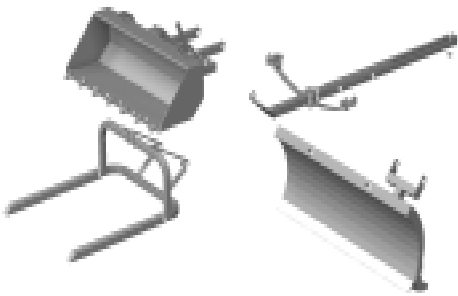

Swisher ATV Quick Switch™ System

**? Did You Know ?**

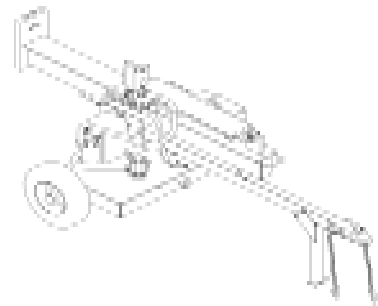

Swisher Log Splitters

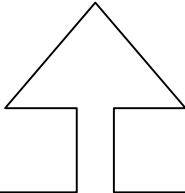

Swisher products pioneered tag along type residential mowers in the 1980's with its 40'' Trailmower.® Today, Swisher offers a full line of products which include log splitters, and a wide range of ATV accessories.

# Notes





## **OWNER'S MANUAL**

### **MODEL NO.**

**FT1150**

## **50" UNIVERSAL MOUNT TRAILMOWER®**

Each mower has its own model number. Each engine has its own model number. The model number for the mower will be found on the right hand side of the drive belt housing. The model number for the engine will be found on the top of the valve cover.

All mower parts listed herein may be ordered directly from Swisher Mower & Machine Co., Inc. or your nearest Swisher dealer.

All engine parts may be ordered from the nearest dealer of the engine supplied with your mower.

WHEN ORDERING PARTS, PLEASE HAVE THE FOLLOWING INFORMATION AVAILABLE:

- \* PRODUCT – 50" UNIVERSAL MOUNT
- \* SERIAL NUMBER - \_\_\_\_\_
- \* MODEL NUMBER - \_\_\_\_\_
- \* ENGINE MODEL NUMBER - \_\_\_\_\_  
TYPE - \_\_\_\_\_
- \* PART NUMBER WITH PAINT CODE
- \* PART DESCRIPTION

TELEPHONE - 1-800-222-8183

FAX - 1-660-747-8650

**SWISHER MOWER & MACHINE CO., INC.**

1602 CORPORATE DRIVE

P.O. BOX 67

WARRENSBURG, MO 64093



**SWISHER MOWER & MACHINE CO., INC.**