

OPERATING INSTRUCTIONS MANUAL

(Please retain for future reference)

For

FVO-400 INDIRECT FIRED SPACE HEATERS



CERTIFIED FOR USE IN CANADA AND U.S.A.
As per CSA B140.8 Portable Oil Fired Heaters / CSA B140.02003 Oil Burning Equipment
Construction Heaters Unattended Type.

Issue date October 1, 2008



FLAGRO INDUSTRIES LIMITED
ST. CATHARINES, ONTARIO
CANADA

GENERAL HAZARD WARNING:

FAILURE TO COMPLY WITH THE PRECAUTIONS AND INSTRUCTIONS PROVIDED WITH THIS HEATER, CAN RESULT IN DEATH, SERIOUS BODILY INJURY AND PROPERTY LOSS OR DAMAGE FROM HAZARDS OF FIRE, EXPLOSION, BURN, ASPHYXIATION, CARBON MONOXIDE POISONING, AND/OR ELECTRICAL SHOCK.

ONLY PERSONS WHO CAN UNDERSTAND AND FOLLOW THE INSTRUCTIONS SHOULD USE OR SERVICE THIS HEATER.

IF YOU NEED ASSISTANCE OR HEATER INFORMATION SUCH AS AN INSTRUCTIONS MANUAL, LABELS, ETC. CONTACT THE MANUFACTURER.

WARNING:

FIRE, BURN, INHALATION, AND EXPLOSION HAZARD. KEEP SOLID COMBUSTIBLES, SUCH AS BUILDING MATERIALS, PAPER OR CARDBOARD, A SAFE DISTANCE AWAY FROM THE HEATER AS RECOMMENDED BY THE INSTRUCTIONS. NEVER USE THE HEATER IN SPACES WHICH DO OR MAY CONTAIN VOLATILE OR AIRBORNE COMBUSTIBLES, OR PRODUCTS SUCH AS GASOLINE, SOLVENTS, PAINT THINNER, DUST PARTICLES OR UNKNOWN CHEMICALS.

WARNING:

NOT FOR HOME OR RECREATIONAL VEHICLE USE.

WARNING:

INTENDED USE IS PRIMARILY THE TEMPORARY HEATING OF BUILDINGS UNDER CONSTRUCTION, ALTERATION, REPAIR OR EMERGENCIES ONLY.

ALWAYS PROVIDE ADEQUATE VENTILATION. 1 SQ. IN. OF FRESH AIR MUST BE SUPPLIED FOR EVERY 1000 BTUH OF HEAT.

THIS HEATER SHALL BE INSTALLED SUCH THAT IT IS NOT DIRECTLY EXPOSED TO WATER SPRAY, AND/OR DRIPPING WATER.

This heater is designed and approved for use as a construction heater under CSA B140.8 Portable Oil Fired Heaters / CSA B140.02003 Oil Burning Equipment.

We cannot anticipate every use which may be made of our heaters. CHECK WITH YOU LOCAL FIRE SAFETY AUTHORITY IF YOU HAVE QUESTIONS ABOUT APPLICATIONS.

Other standards govern the use of fuel gases and heat producing products in specific applications. Your local authority can advise you about these.

SPECIFICATIONS

Model	FVO-400
Input	390,000 btuh
Fuel	No.1, No. 2, diesel or kerosene
Fuel Pressure	170 psi
Nozzle	2.25 x 45B
(Delavan)	
Ignition	Direct Spark
.....	Thermostat Control
Air Circulation	2500 cfm
Fuel Consumption	2.75 Gal/hr
Approved	cETLus listed

INSTALLATION:

The installation of this heater for use with No.1, No.2, Diesel or Kerosene and shall conform with local codes or, in the absence of codes, with the National Fuel Gas Code ANSI Z223.1/NFPA 54. Installation of the unit shall be in accordance with the regulations of the authorities having jurisdiction or the CSA Standard B139.

CLEARANCE TO COMBUSTIBLES:

<u>TOP</u>	<u>FRONT</u>	<u>SIDES</u>	<u>REAR</u>	<u>FLUE PIPE</u>
3 ft	10 ft	3 ft	3 ft	3 ft

FUEL:

This heater will operate with No.1, No.2, Diesel or Kerosene.

Note: No.1 Fuel Oil or Kerosene must be used for temperatures less than -10°C (8°F).

ELECTRICAL:

WARNING Electrical Grounding Instructions

This appliance is equipped with a three-prong (grounding) plug for your protection against shock hazard and should be plugged directly into a properly grounded three-prong receptacle.

115v supply must be available. Please note that the heater requires 15 amps for proper operation. Ensure appropriate gauge extension cord is used.

- 12/3 AWG at 50 Feet
- 10/3 AWG at 100 Feet

FLUE PIPE:

Flue pipe connection must terminate with a vertical run at least 2ft long.

The vent outlet on the heater is 6" diameter. Certified venting must be used at all times. Vent cap should be installed in situations where downdrafts occur. All venting must correspond with the CSA B149 standard or in its absence, local codes.

FV SERIES CONSTRUCTION HEATER – VENTING REQUIREMENTS

1. VERTICAL FLUE TERMINATIONS

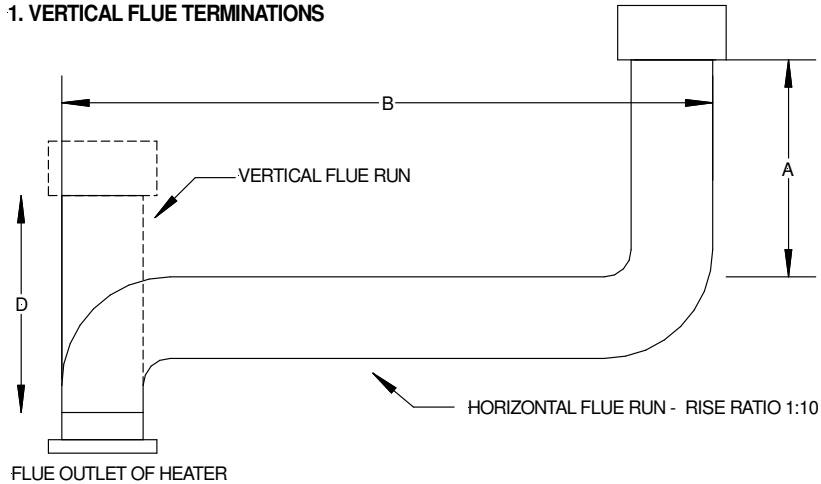

2. HORIZONTAL FLUE TERMINATIONS

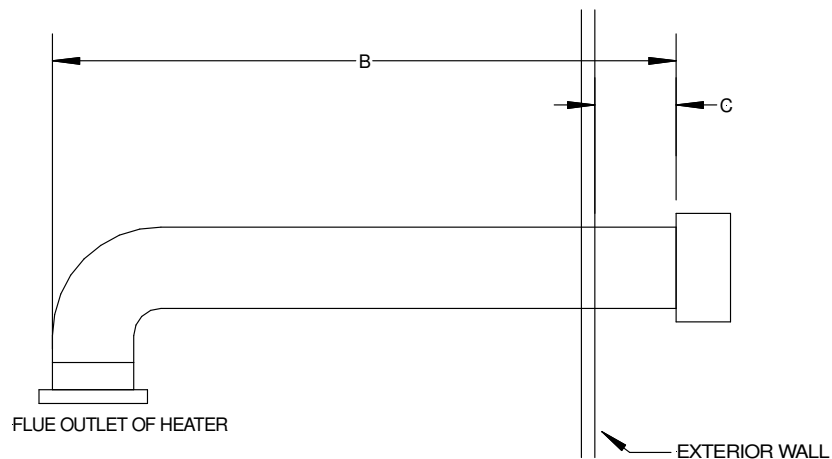

- A - VENT TERMINATION MUST BE A MINIMUM OF 2FT HIGHER THAN ANY POINT WITHIN 10FT.
- B - MAXIMUM HORIZONTAL RUN IS 30FT.
NOTE: 90deg ELBOW = 10ft HORIZONTAL VENT ALLOWANCE
45deg ELBOW = 5ft HORIZONTAL VENT ALLOWANCE
- C - VENT TERMINATION IN HORIZONTAL POSITION MUST BE MINIMUM 4ft FROM ANY COMBUSTABLE SURFACE
- D - EXTERIOR VERTICAL VENT TERMINATION MUST BE A MINIMUM OF 2ft.

NOTE: ALL VENT TERMINATIONS MUST HAVE A RAIN CAP INSTALLED AS PER LOCAL CODE REQUIREMENTS.

DUCTING: Canvas heater duct with a minimum temperature handling of 300 deg F. including wire reinforcement to prevent collapsing. Heater is designed for use with 2 x 12" diameter ducts equipped with pin lock couplings (FV-D12).

Install ducting to outlet on the heater using pin-locks provided on collar of ducting. Ducting should be inspected periodically for tearing and/or wear marks. Ducting should be stored in a dry area when not in use

MAINTENANCE:

1. **Every construction heater should be inspected before each use, and at least annually by a qualified service person. Incorrect maintenance may result in improper operation of the heater and serious injury could occur.**
2. Service and Maintenance only to be performed by a qualified service person.
3. The hose assemblies shall be visually inspected prior to each use of the heater. If it is evident there is excessive abrasion or wear, or the hose is cut, it must be replaced prior to the heater being put into operation. The replacement hose assembly shall be that specified by the manufacturer.
4. The flow of combustion and ventilation air must not be obstructed. Be sure to check the fan assembly and ensure that the motor and blade are operating properly.
5. Compressed air should be used to keep components free of dust and dirt build up. Note: Do not use the compressed air inside any piping or regulator components.
6. Change fuel filter insert (Part# FVO-418) once per month. Change fuel filter cartridge (Part# FVO-419) once every 6 months.
7. Change oil nozzle (Part# FV-435) once per year.
8. Fan Limit Switch (Part# FV-407A) should be replaced if the fan motor does not shut off after the heat exchanger has cooled down.
9. The High Limit Switches (Part# FV-406 & FV-437) should be checked each season. These limit switches will ensure the burner shuts down if the temperature exceeds 150° F at rear of unit and 290° F at the outlet.
10. Fuel tank should be drained on a regular basis by removing drain plug.
11. **CAUTION** – Do not have any source of ignition near the heater when draining tank.

NOTE: No.1 fuel oil or kerosene is recommended for temperatures below
-10° C / 8° F

11. Heat Exchanger should be cleaned if smokey conditions continue even after the air adjustments on the burner are made.

START UP INSTRUCTIONS:

1. Be sure the switch in is the “OFF” position.
2. Ensure electrical cord is grounded and heater is on a level surface.
3. Plug in supply cord to 115V 15amp outlet.
4. Move switch to “MANUAL” position for manual control.
5. Move switch to “THERMOSTAT” position for thermostatic control.

Please Note:

1. If using Thermostat on unit, unit must be started in Thermostat position.
2. When changing between manual and thermostat operation, the heater must be left in the “OFF” position for 30 seconds to prevent the burner from locking out.
3. When using a generator for electrical supply, make sure the generator is properly grounded and generator is at a 60Hz frequency.
4. In the event that a Generator is being used and the generator runs out of fuel, make sure the heater switch is in the “OFF” position before restarting generator, failure to do so may damage heater.

TO SHUT DOWN:

1. Move switch to “OFF” position.

NOTE: Fan will continue to operate after the burner shuts down. Once the unit cools down, the fan will stop.

IF HEATER FAILS TO START:

1. Press manual reset button at rear of burner.
2. Check fuel level. There must be 2-4 gallons of fuel in the tank for the heater to start properly.
3. Make sure there are no air locks in fuel lines or filter.
4. Ensure proper power supply and extension cord is being used.
5. Check for dirty fuel filter or blocked fuel supply line.
6. Check burner nozzle assembly.

NOTE: IF THE BURNER HAS BEEN RESET SEVERAL TIMES THERE MAY BE AN ACCUMULATION OF OIL IN THE CHAMBER! DO NOT CONTINUE TO TRY AND START THE HEATER!

DRAIN OIL FROM HEAT EXCHANGER USING DRAIN HOLE AT FRONT OF HEAT EXCHANGER FOR 15-20 MINUTES BEFORE ATTEMPTING TO RELIGHT. LET REMAINING EXCESS OIL BURN OFF BEFORE CHECKING COMBUSTION OF UNIT.

SAFE OPERATION PRECAUTIONS:

1. Do not fill fuel tank while heater is operation.
2. Do not attempt to start heater if excess oil remains in the heat exchanger.
3. Use switch to shut down the heater. Do not try to shut down the heater by unplugging the electrical cord.
4. Do not plug anything other than the thermostat into the "Thermostat" plug.
5. Do not use any fuel other than those listed on rating plate.
6. Follow electrical requirements shown on rating plate and/or Electrical requirements section of this manual.
7. Before removing any guards or performing any maintenance, be sure that the main power supply is disconnected.

COMBUSTION AIR ADJUSTMENTS:

NOTE: Proper combustion air adjustment must be achieved using a certified combustion analyzer and smoke tester to ensure complete combustion.

The air adjustment should be made to achieve 10% CO₂ and No. 1 or “trace” smoke. (Bacharach Scale)

SETTING THE AIR ADJUSTMENT PLATE

A) Regulation of the combustion air flow is made by adjustment of the manual AIR ADJUSTMENT PLATE (1) after loosening the FIXING SCREWS (2 & 3). The initial setting of the air adjustment plate should be made according to Column 5 in the Burner Set-up Chart.

B) The proper number on the manual AIR ADJUSTMENT PLATE (1) should line up with the SETTING INDICATOR (4) on the fan housing cover. Once set, the air adjustment plate should be secured in place by tightening SCREWS 2 and 3.

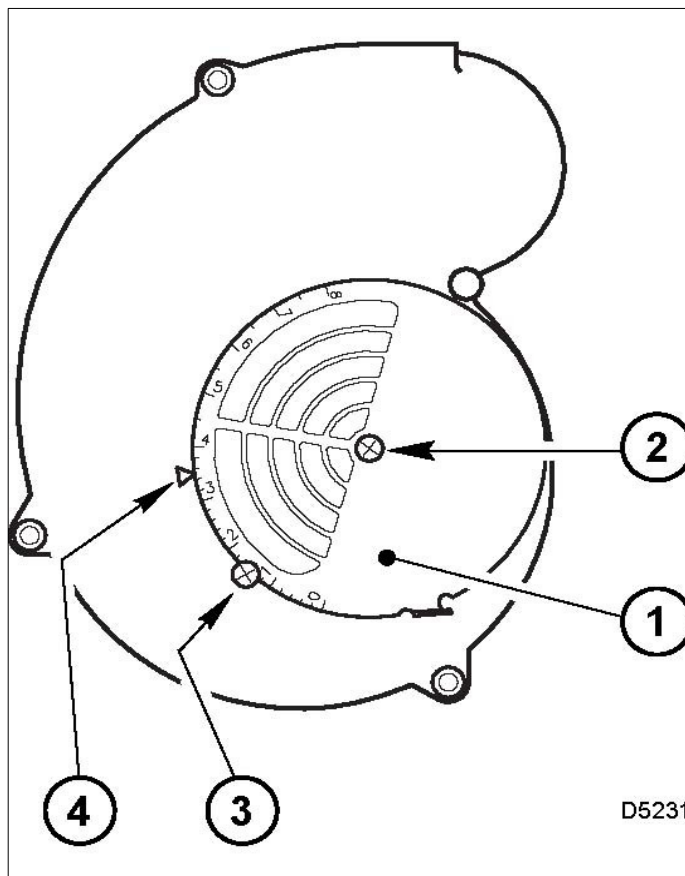

C) The final position of the air adjustment plate will vary on each installation. Use instruments to establish the proper settings for maximum CO₂ and a smoke reading of zero.

NOTE: Variations in flue gas, smoke, CO₂ and temperature readings may be experienced when the burner cover is put in place. Therefore, the burner cover **must** be in place when making the final combustion instrument readings, to ensure proper test results.

BURNER SET-UP CHART

1	2	3		4	5
ACTUAL FIRING RATE ± 5%	NOZZLE SIZE	PUMP PRESSURE		TURBULATOR SETTING	AIR DAMPER SETTING
GPH	GPH	PSI	BAR		
2.75	2.25 x 45°	150	10	5	4 - 6

* Note – Air damper setting is typically set at 4 for operation in colder temperatures. A combustion analyzer should always be used when setting the burner.

TEMPERATURE FEELER GAUGE ADJUSTMENT (ATTACHED TO FAN SWITCH)

The temperature feeler gauge is required to be always touching the heater exchanger.

The temperature feeler gauge controls the air flow over the fan switch, which eliminates any unnecessary fan cycling. The temperature feeler gauge can be adjusted for different outside temperatures, by rotating the location of the temperature feeler gauge holes. This will provide maximum performance of the unit in different applications.

If supply air is warm (-5° C, indoor application):

Turn the temperature feeler gauge so that the holes are parallel with the heat exchanger. This will help the fan switch to remain cool and not overheat. See following:

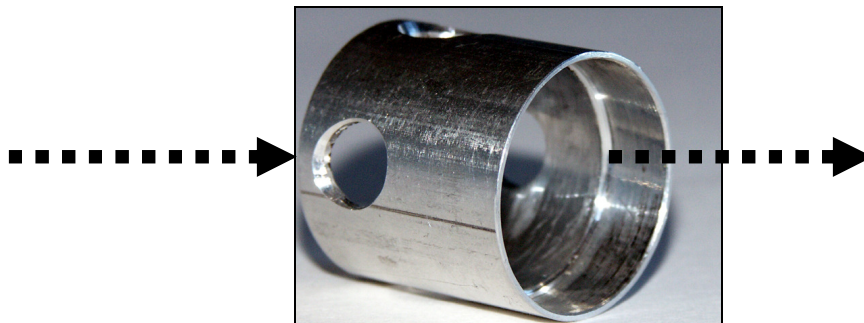

If supply air is cold (under -5°C):

Turn the temperature feeler gauge so that the holes are closed off as the air goes over the heat exchanger. This will reduce fan cycling and the unit from shutting down. See following:

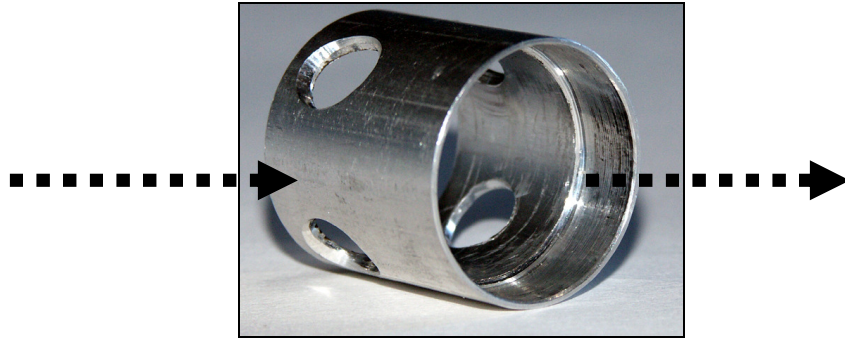

In extreme cold conditions, cover the holes on the temperature feeler gauge using foil tape. Ensure that the temperature feeler gauge is readjusted for warmer weather conditions. Failure to do so may result in burning out fan switches- not covered under warranty.

ELECTRICAL CONNECTIONS

It is advisable to leave the control box off the sub-base while completing the electrical connections to the burner.

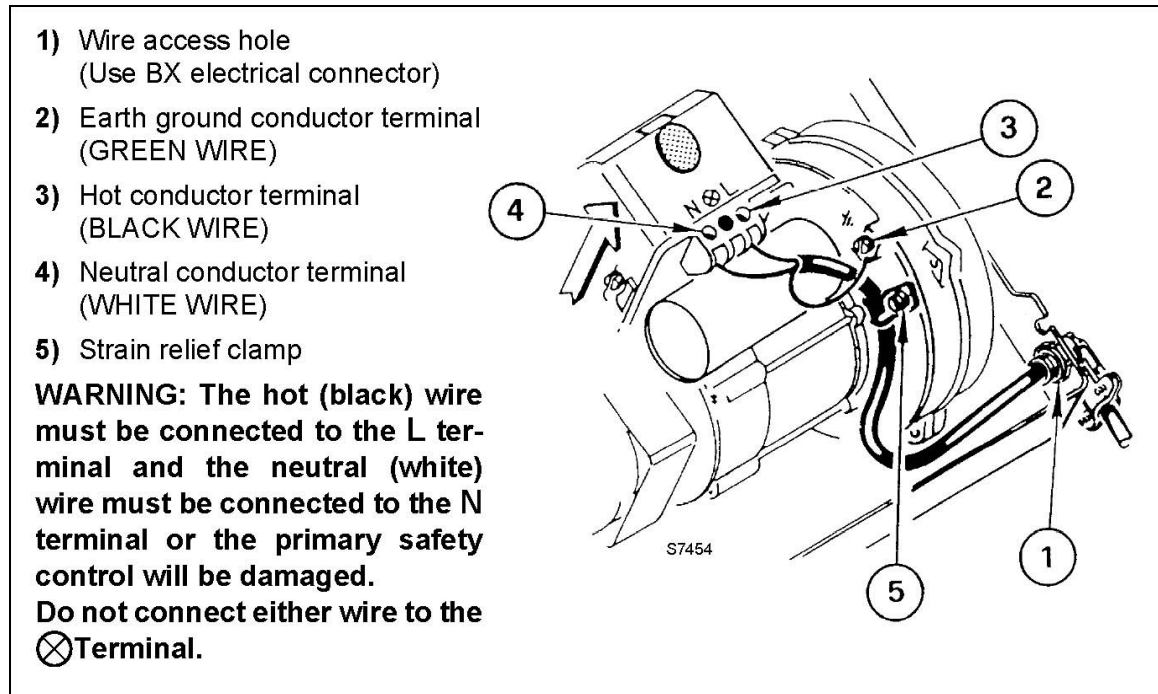

The burner may be controlled using either a DIRECT LINE VOLTAGE control circuit (120V AC 60 cycle) **OR** a LOW VOLTAGE control (24V AC 60 cycle) using a R8038A Honeywell switching relay or equivalent.

Using the appropriate diagram below, make electrical connections to the burner. All wiring must be done in accordance with existing electrical codes, both national and local.

When all electrical connections have been made, the control box may be put back in place on the sub-base.

WARNING: DO NOT activate burner until proper oil line connections have been made, or failure of the pump shaft seal may occur.

APPLICATION FIELD WIRING

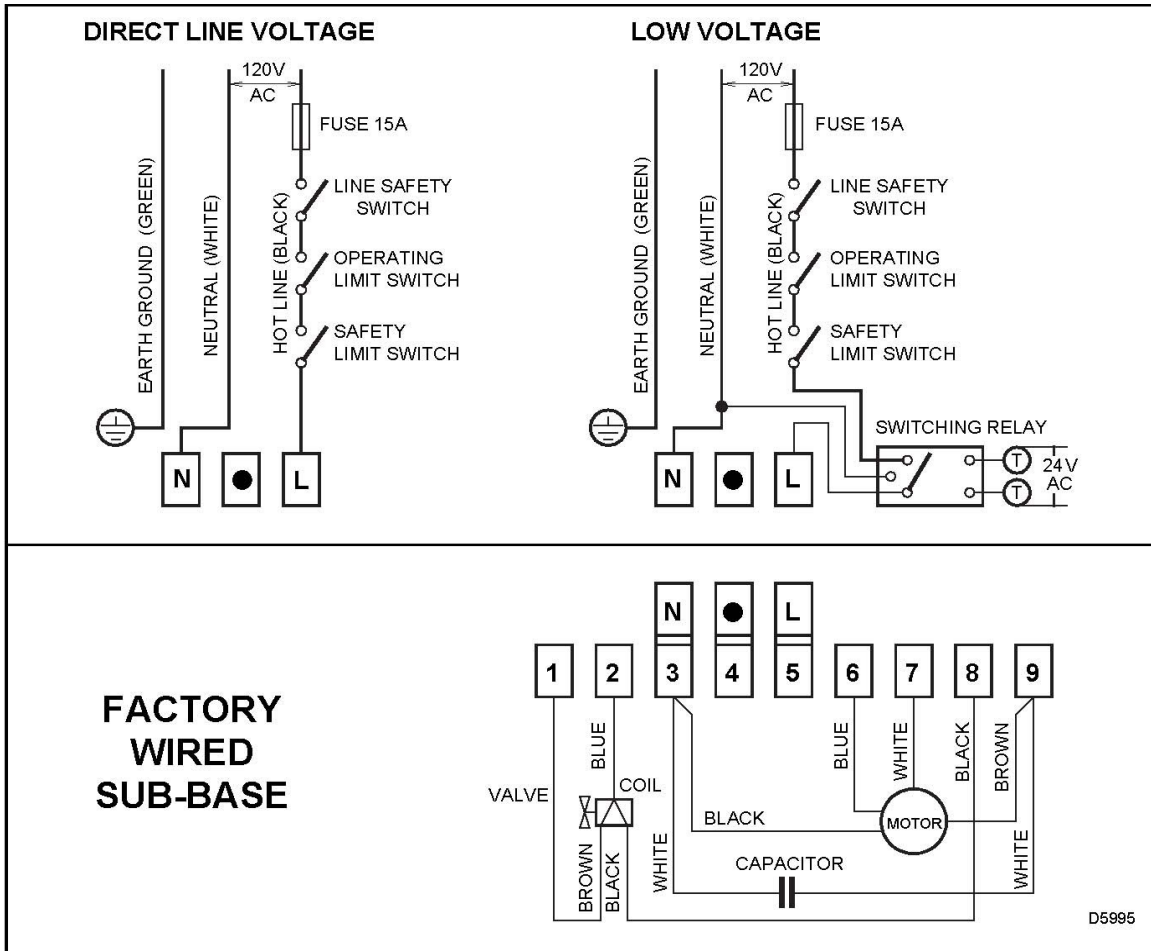

REMOTE SENSING OF SAFETY LOCKOUT: The SAFETY SWITCH in the 530SE CONTROL BOX is equipped with a contact allowing remote sensing of burner lockout. The electrical connection is made at terminal 4 (●) on the SUB-BASE. Should lockout occur the 530SE CONTROL BOX will supply a power source of 120Vac to the connection terminal. The maximum allowable current draw on this terminal (4) is 1 Amp.

WARNING: If a neutral or ground lead is attached to this terminal, the CONTROL BOX on the burner will be damaged should lockout occur.

INSERTION / REMOVAL OF DRAWER ASSEMBLY

- A)** To remove drawer assembly, loosen SCREW (3), then unplug CONTROL BOX (1) by carefully pulling it back and then up.
- B)** Remove the AIR TUBE COVER PLATE (5) by loosening the two retaining SCREWS (4).
- C)** Loosen SCREW (2), and then slide the complete drawer assembly out of the combustion head as shown.
- D)** To insert drawer assembly, reverse the procedure in items A to C above, and then attach fuel line to the pump.

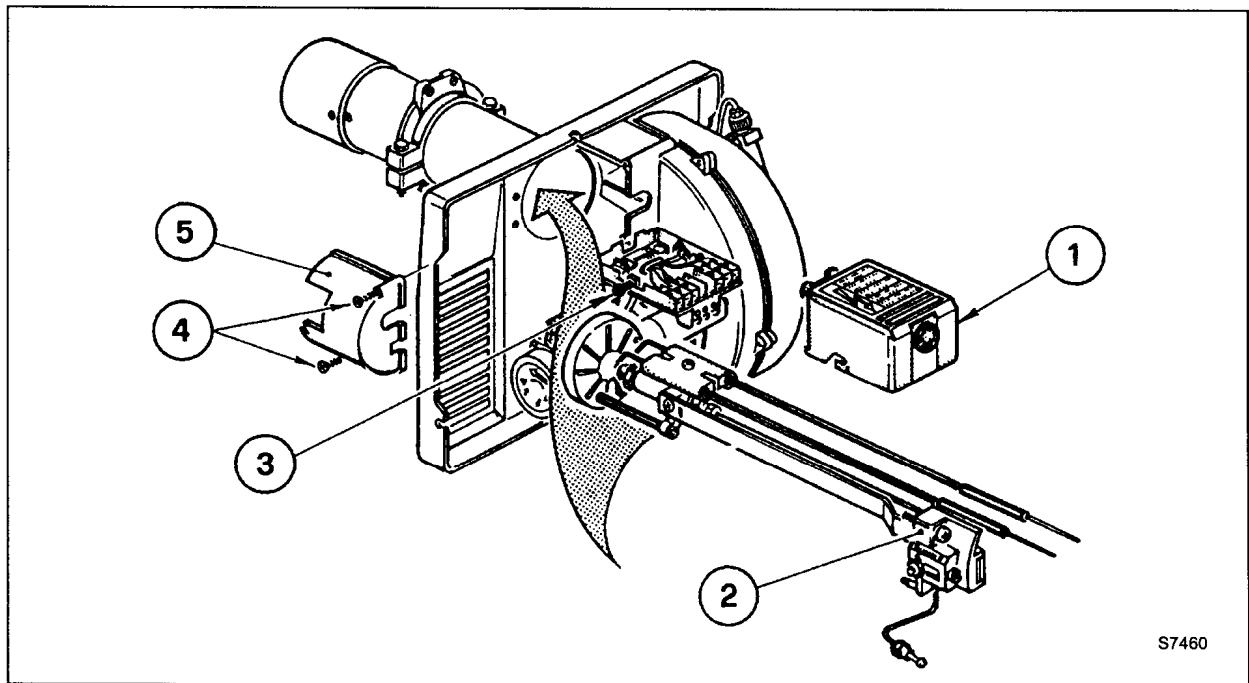

NOZZLE PLACEMENT

- A) Remove the NOZZLE ADAPTER (2) from the DRAWER ASSEMBLY by loosening the SCREW (1).

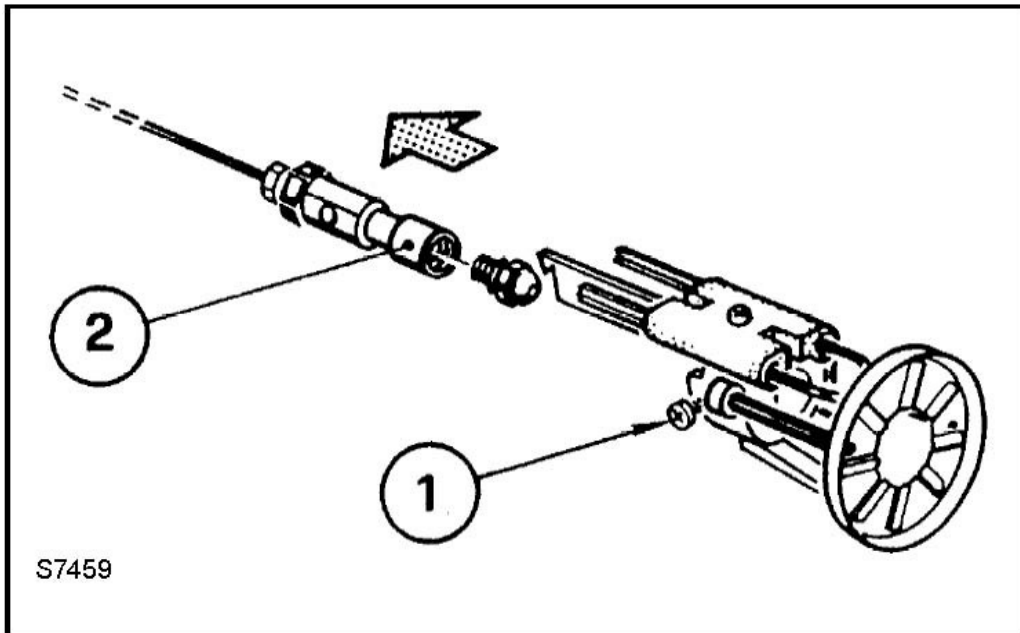

- B) Insert the proper NOZZLE into the NOZZLE ADAPTER and tighten securely (Do not over tighten).
- C) Replace adapter, with nozzle installed, into drawer assembly and secure with screw (1).

ELECTRODE SETTING

IMPORTANT:

THESE DIMENSIONS MUST BE OBSERVED AND VERIFIED.

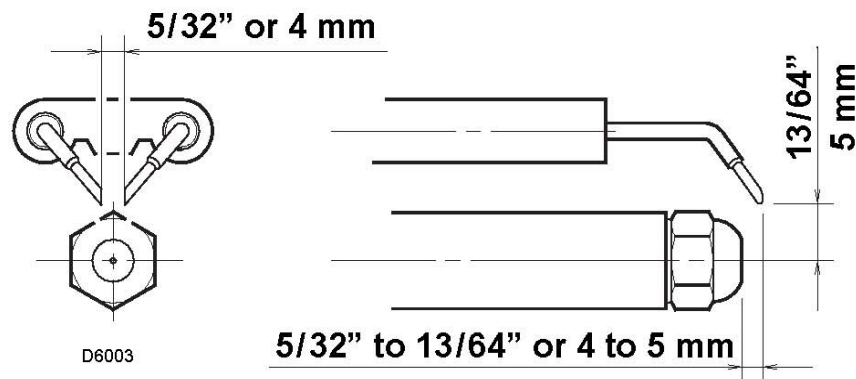

TURBULATOR SETTING

- A)** Loosen NUT (1), then turn SCREW (2) until the INDEX MARKER (3) is aligned with the correct index number as per the Burner Set-up chart, on page 12.
- B)** Retighten the RETAINING NUT (1)

NOTE: Zero and five are scale indicators only. From left to right, the first line is 5 and the last line 0.

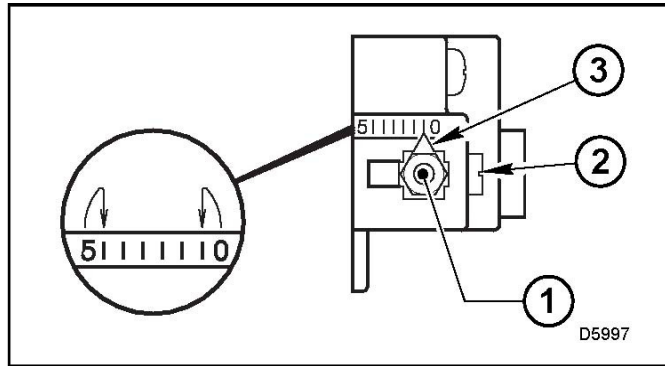

OIL LINE CONNECTIONS

Note: Pump pressure must be set at time of burner start-up. A pressure gauge is attached to the PRESSURE PORT (8) for pressure readings. Two PIPE CONNECTORS (5) are supplied with the burner for connection to either a single or a two-pipe system. Also supplied are two ADAPTORS (3), two female 1/4" NPT, to adapt oil lines to burner pipe connectors. All pump port threads are British Parallel Thread design. Direct connection of NPT threads to the pump will damage the pump body. Riello manometers and vacuum gauges do not require any adaptors, and can be safely connected to the pump ports. An NPT (metric) adapter must be used when connecting other gauge models.

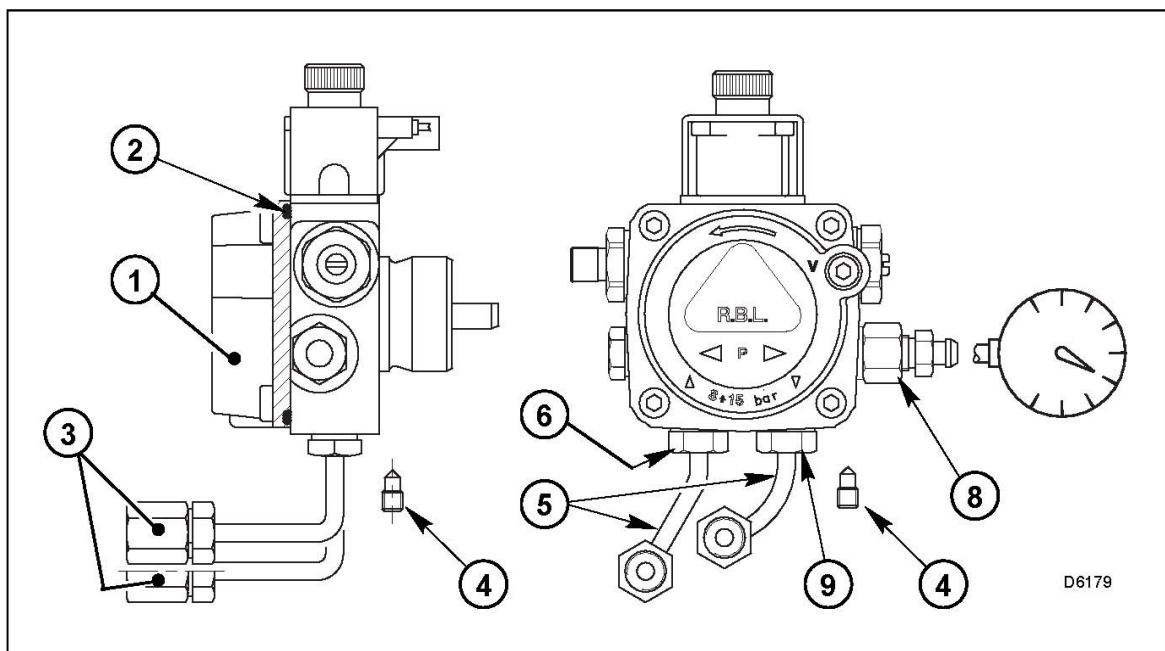

FV-400 SERIES - WIRING SCHEMATIC

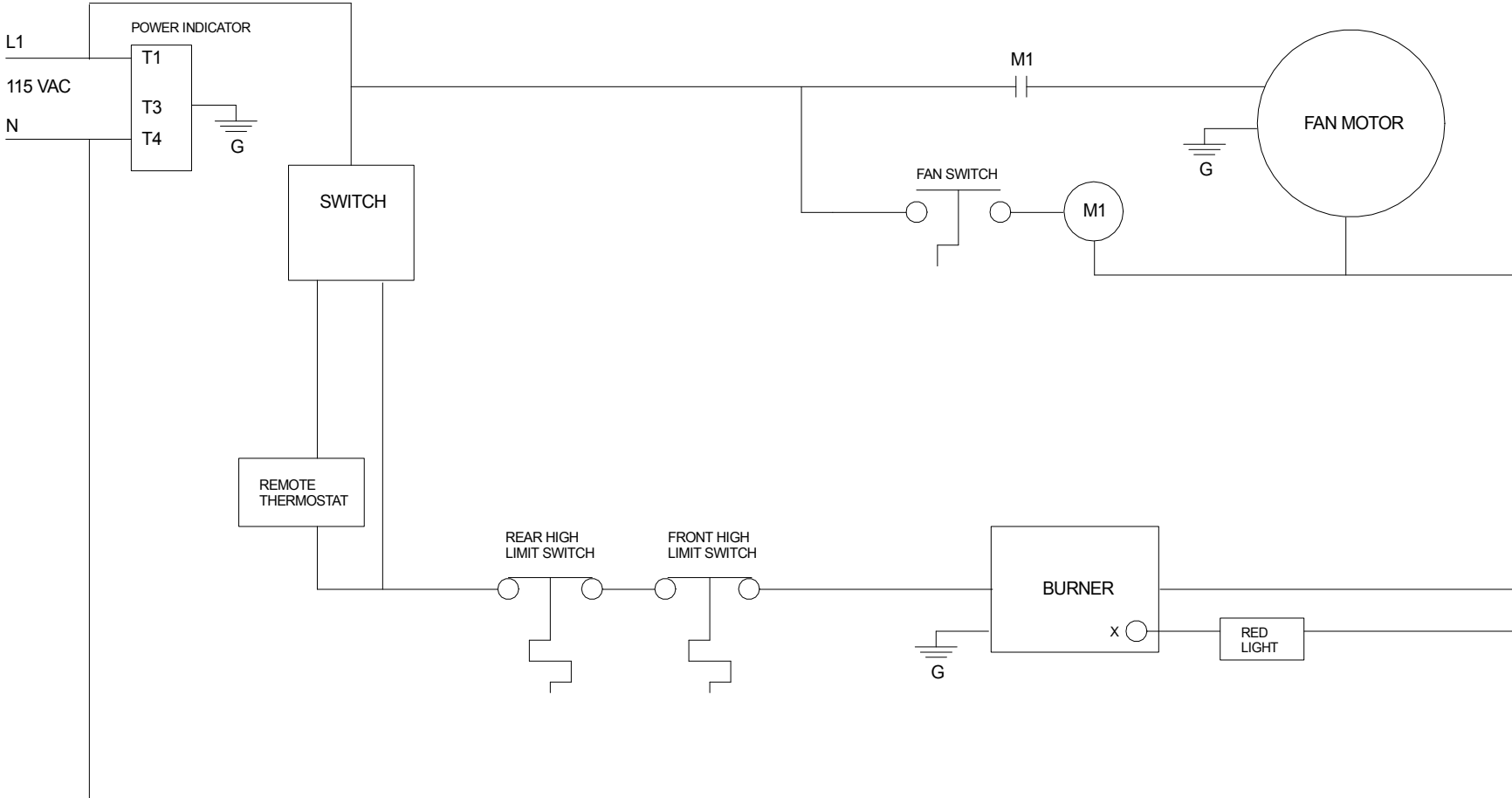

FLAGRO INDUSTRIES LIMITED	
TITLE: FVO-400 - WIRING SCHEMATIC	DWG. NO. FV-400 WS

POWER SUPPLY INDICATOR LIGHT - NEW FOR 2009/2010 FVO-400 & FVNP-400

Control Box

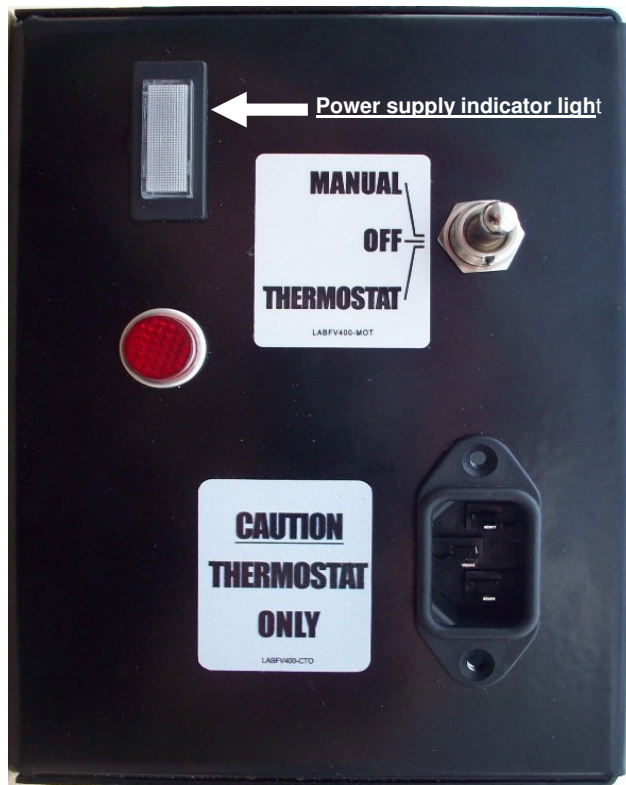

* The power supply indicator light will help you detect any faulty power supplied to the heater.

* The power supply indicator light will detect various power supply issues such as; gounding issues or reverse Polarity or missing connections

Warning Light Indications

The smart indicator can detect and display the following fault conditions:

<u>Green Light</u>	→	<u>Meets Power Requirements</u>
<u>Solid Red Light</u>	→	<u>Reverse Polarity</u>
<u>Flashing Red Light</u>	→	<u>Ground or Neutral issue</u>

**** ATTENTION****

IF RED LIGHT IS INDICATED, MAKE CORRECTIONS TO POWER SUPPLY BEFORE TURNING HEATER ON. FAILURE TO DO SO.

WILL VOID ANY WARRANTY

flagro
INDUSTRIES LIMITED

www.flagro.on.ca

Indirect Fired Heater FVO-400 Parts List



Indirect Fired Heater FVO-400 Parts List

Front

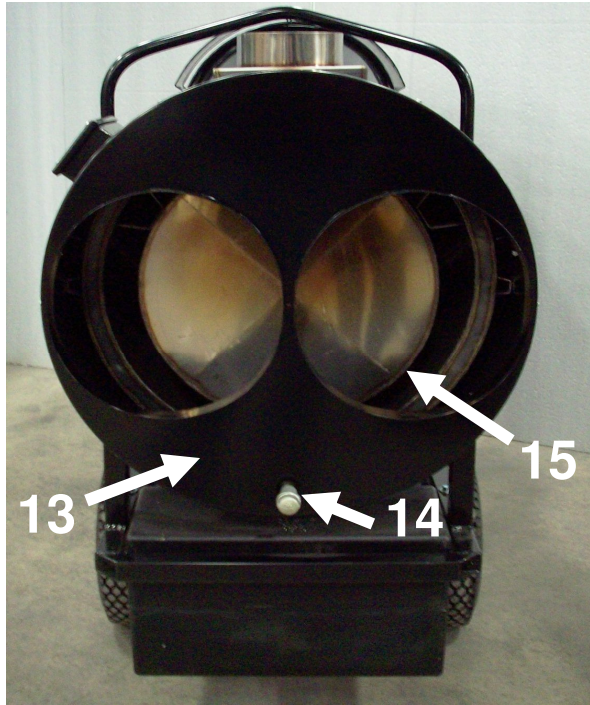

Fan Limit Switch accessories



Oil Filter

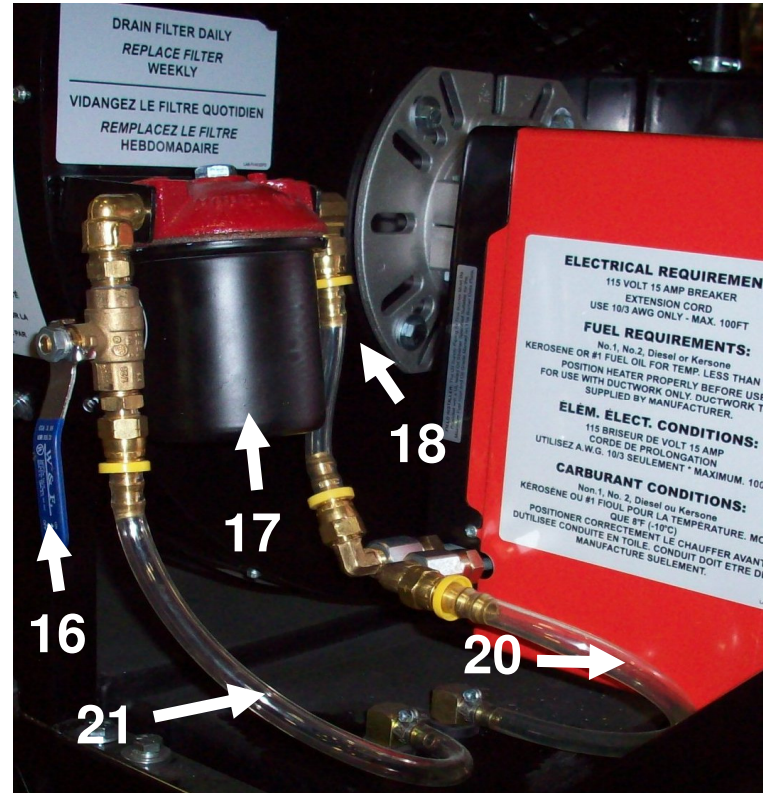

Rear Limit Switch Box

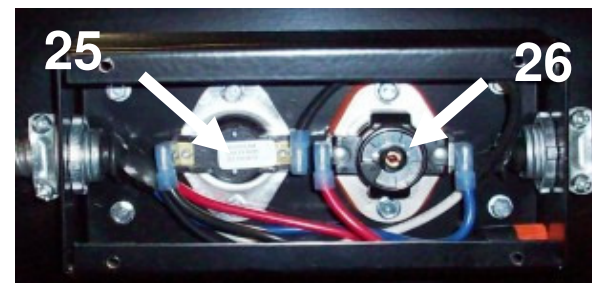

Indirect Fired Heater FVO-400 Parts List

Front Limit Switch Box

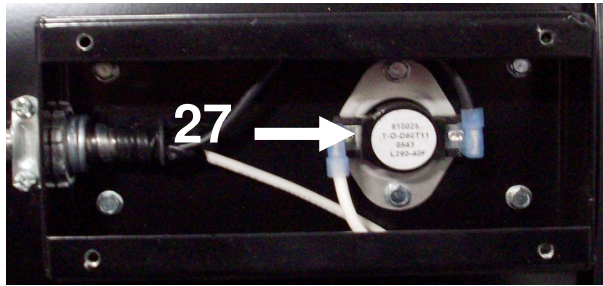

Control Box



Inside Control Box



Fan and Motor

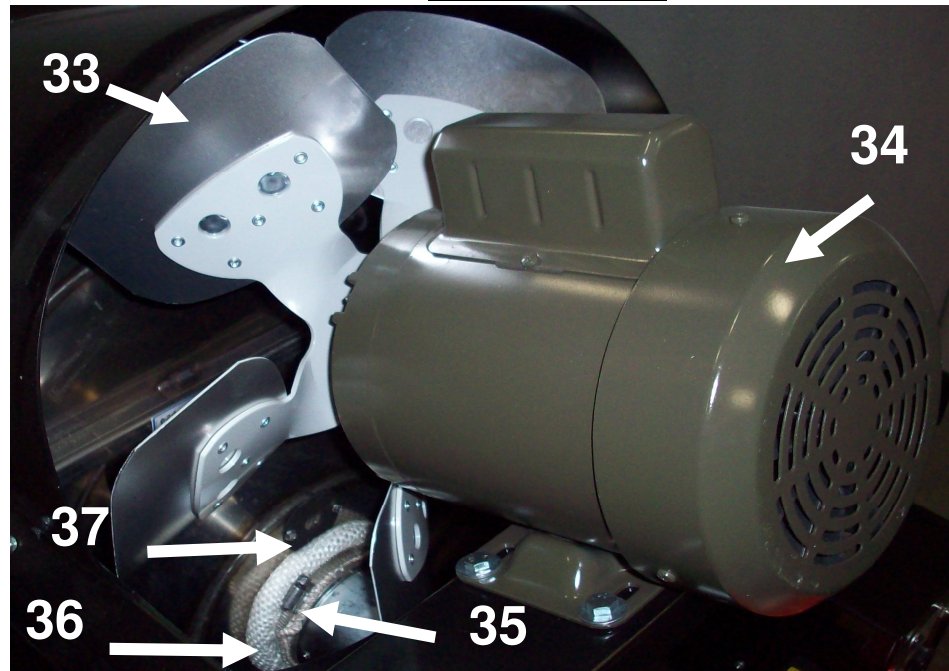

Indirect Fired Heater FVO-400 Parts List

<u>Item #</u>	<u>Description</u>	<u>P/N</u>	
1	Fan Motor Canopy	FV-408	
2	Lifting Harness	FV-438	
3	High Limit Box (Single Hole)/Box Cover	FV-P11	FV-P12
4	48 US Gallon Oil Tank	FVO-416	
5	16 " Wheel	FV-403	
6	Oil Tank Cap (poly Tank)	FVO-417B	
7	Fan Limit Box (Double Hole)/Box Cover	FV-P10	FV-P12
8	Oil Frame	FVO-FR	
8A	Fuel Tank harness	FV-P17	
9	Legs	FV-P13	
10	18" Power Cord	FV-404	
11	Control Box/ Box Cover	FV-P08A	FV-P09
12	Riello Burner F-10	FVO-415	
13	Front Duct Outlet Panel	FV-P03	
14	1/2 X 7" GALV NIPPLE & CAP	40-113-D7GALV	40-108-8GALV
15	SS Heat Exchanger	FV-405	
16	3/8 On/Off Ball Valve	2103-C-CGA	
17	Fuel Filter (complete)	FVO-418	
18	Oil Fuel Line 7" (Filter to Burner)	FVO-421	
20	Oil Fuel Return line 10 1/2 " (Burner to Tank)	FVO-422	
21	Oil Fuel line 15" (Tank to Filter)	FVO-420	
22	Fan Limit Silicone Gasket	FV-407G	
23	Solid Feeler Gauge	FV-433B	
24	Feeler Gauge	FV-433	
25	High Limit (Rear) 150 F	FV-437	
26	Fan Limit Switch (Adjustable)	FV-407A	
27	High Limit Switch (Outlet) 290 F	FV-406	
28	Power Supply Indicator Light 2009> (green light - 2009<	FV-449SI	FV-410
29	Red Light (on control box	FV-411	
30	Toggle Switch (on control box)	FV-409	
31	Thermostat Plug (on control box) 2008>	FV-414A	Prior -FV-414
32	Main Relay	FV-448	
33	16" Fan Blade	FV-402	
34	3/4 H.P. Fan Motor	FV-401	
35	Burner Gasket Clamp	HC5-64	
36	Burner Gasket	FV-431	
37	Sight Glass w/Gasket	FV-446/FV-447	
38	12" X 12 FT Canvas Ducting	FV-D12	
39	Thermostat w/ 25Ft Cord - Female Plug 2008>	FV-THA	
40	Thermostat w/ 25Ft Cord - Male Plug 2007<	FV-TH	

Accessories

