

Owner's Manual

ACG4-2800 Series Dual Power System

⚠ DANGER	
Using a generator indoors WILL KILL YOU IN MINUTES.	
Exhaust contains carbon monoxide, a poison gas you cannot see or smell.	
	
NEVER use in the home or in partly enclosed areas such as garages.	ONLY use outdoors and far from open windows, doors, and vents.
⚠ PELIGRO	
Utilizar un generador dentro LE MATARA EN MINUTOS	
El escape contiene monóxido de carbono, un gas tóxico usted no lo puede ver ni oler	
	
NUNCA utilice en el hogar ni en áreas en parte encerradas tales como garajes.	SOLAMENTE usolo fuera y lejos de ventanas abiertas, puertas, y respiraderos.

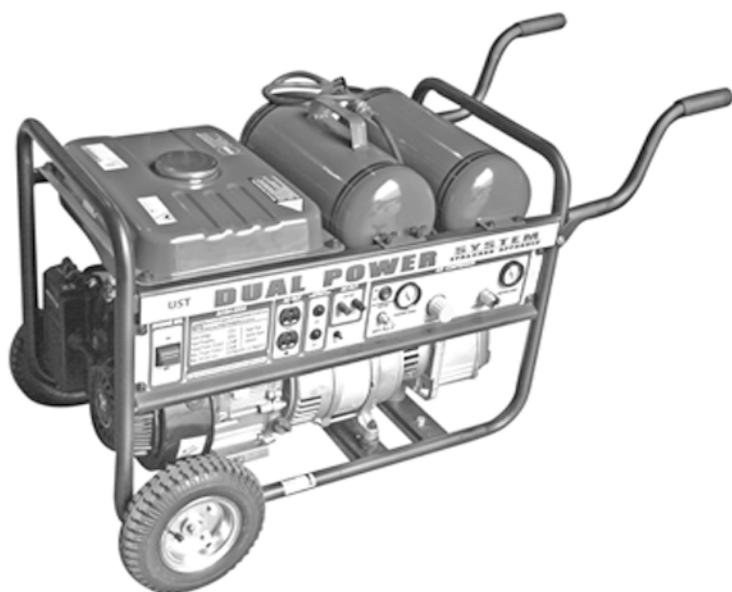

Warranty Information Do Not Return To Store

One year Limited Manufacturer's Warranty for Missing parts, Damage or Service

Products are not to be returned to retailer

Service is available from a network of providers nationwide

To identify a provider in your area or for warranty information call toll free

866 797 2738

Read carefully before attempting to assemble, install, operate or maintain the product described. Protect yourself and others by observing all safety information. Failure to comply with the user's manual could result in personal injury and/or property damage! Retain the user's manual for future reference. Call toll free number 866 797 2738 for parts and service.

Distributed by  Fullerton, CA 92833

CONTENTS

1.GENERATOR SAFETY	2
2.AIR COMPRESSOR SAFETY	2
3.COMPONENT IDENTIFICATION.....	3
4.PRE-OPERATION CHECK	4
5.STARTING THE ENGINE	5
6.GENERATOR USE.....	6
7.AIR COMPRESSOR USE	8
8.STOPPING THE ENGINE.....	9
9.MAINTENANCE.....	10
10.STORAGE.....	12
11.TROUBLESHOOTING.....	12
12.WIRING DIAGRAM	14
13.SPECIFICATIONS	14
14. PART ASSEMBLY.....	15

Warranty and Service Questions ?
Missing or Damaged parts
Call 866 797 2738

1. GENERATOR SAFETY



DO NOT USE INSIDE HOUSE.

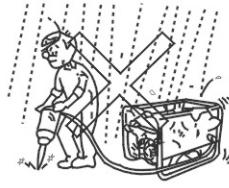

DO NOT USE IN WET SURROUNDING.



DO NOT CONNECT TO HOUSEHOLD CIRCUIT.

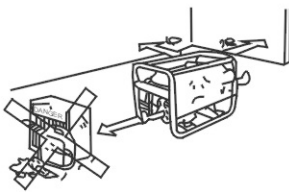

KEEP FLAMMABLE MATERIAL AT LEAST 1m(3FT).



NO SMOKING.



DO NOT SPILL.



STOP ENGINE.

2. AIR COMPRESSOR SAFETY

- a. **RISK OF BURSTING.** Rust can weaken the air tank. Drain the condensed water from the air tank after each use to reduce rusting. If a leak is detected in the air tank, replace the tank immediately. Do not weld, drill or modify the air tank of this compressor. Welding or modifications on the air compressor tank can severely impair air tank strength and cause an extremely hazardous condition. Welding or modifying the air tank in any manner will void the warranty.
- b. **RISK OF BURSTING.** Check the manufacturer's maximum pressure rating for air tools and accessories that you will be using. The air compressor's outlet pressure must be regulated to never exceed the maximum pressure rating of the tool. Before attaching or removing accessories or air tools from the air hose, close the air release valve and relieve all air pressure in the air hose, see Figure 5.
- c. **RISK OF BURNS.** The pump and manifold generate high temperatures. To prevent burns or other injuries, DO NOT touch the pump, manifold or transfer tube while the pump is running. Allow them to cool before handling or servicing. Keep children away from the air compressor at all times.
- d. **RISK TO BREATHING.** Be certain to read all labels when you are spraying paints or toxic materials, and follow the safety instructions. Use a respirator mask if there is a chance of inhaling anything you are spraying. Read all instructions, and be sure that your respirator mask will protect you.
- e. **RISK OF EYE INJURY.** Always wear ANSI Z87.1 approved safety goggles when using an air compressor. Never point any nozzle or sprayer toward a person or any part of the body. Serious injury can occur if the spray penetrates the skin.

**Warranty and Service Questions ?
Missing or Damaged parts
Call 866 797 2738**

f.RISK OF BURSTING. Do not adjust the pressure switch or relief valve for any reason. Doing so voids all warranties. They have been prset at the factory for the maximum pressure of this unit. Personal injury and/or property damage may result if the pressure switch or the relief valve is tampered with.

g.RISK TO BREATHING. Never directly inhale compressed air produced by an air compressor. This air is not suitable for breathing.

3.COMPONENT IDENTIFICATION

- 1 CHOKE ROD
- 2 FUEL VALVE
- 3 AIR CLEANER
- 4 RECOIL STARTER
- 5 ENGINE SWITCH
- 6 WHEEL
- 7 OIL DRAIN PLUG
- 8 OIL FILLER CAP
- 9 DOUBLE SOCKET
- 10 AC PROTECTOR
- 11 DC PROTECTOR
- 12 GROUND TERMINAL
- 13 DC TERMINALS
- 14 RELIEF VALVE
- 15 AIR COMPRESSOR SWITCH
- 16 TANK PRESSURE GAUGE
- 17 PRESSURE REGULATOR
- 18 COUPLER
- 19 REGULATED PRESSURE GAUGE
- 20 HANDRAIL
- 21 FRAME
- 22 AIR TANK
- 23 PORTABLE AIR TANK
- 24 FUEL TANK CAP
- 25 FUEL TANK
- 26 DRAIN VALVE
- 27 AIR PUMP
- 28 MUFFLER
- 29 SPARK PLUG

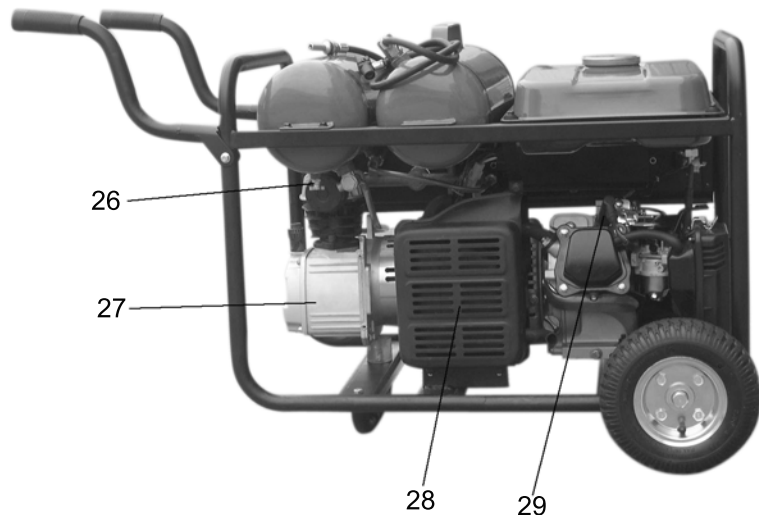
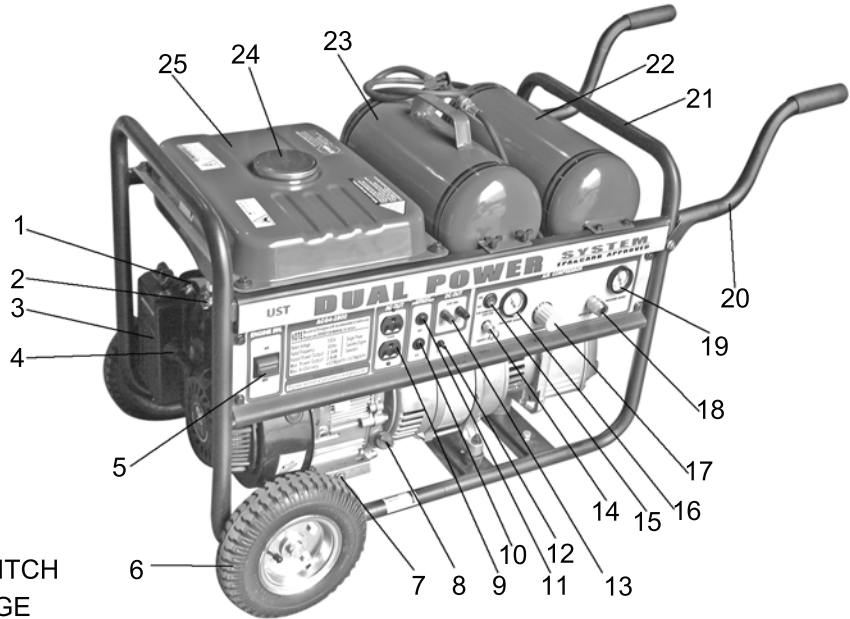

Warranty and Service Questions ?
 Missing or Damaged parts
 Call 866 797 2738

4. PRE-OPERATION CHECK



1. ENGINE OIL LEVEL

CAUTION: Be sure to check the generator engine fluid levels with the generator on a level surface.

Recommended oil: 4-strook motor oil service classification SJ, SL, SG or SAE 10W-30 for general temperature .

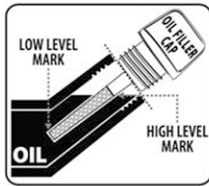

1. Remove the oil filler cap/dipstick and wipe off any oil;
2. Insert the oil filler cap/dipstick into oil filler neck, but do not screw it in! Let the filler cap/dipstick sit above the filler hole then remove it to check the oil level;
3. Add oil if the oil level is low, then reinstall the oil filler cap securely before starting.



2. AIR COMPRESSOR OIL LEVEL

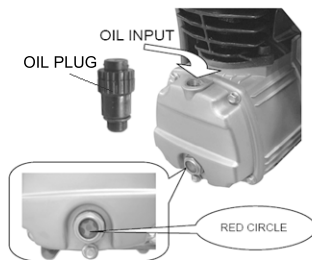

1. Remove the oil plug from the air compressor and, carefully, pour the lubricating oil into the oil nozzle.
2. Replace oil plug after filling.

CAUTION: Keep an eye on the oil level through the oil glass, and stop pouring when the oil level is within the RED CIRCLE.

If the oil level is below the red circle as viewed through the oil glass, the air compressor's oil is too low. Operating the air compressor without sufficient oil will result in excessive wear and could damage the unit.

Replace the lubricating oil after running the air compressor for fifty(50) hours. Use non-detergent, SAE 30W oil



3. FUEL LEVEL

1. Remove the fuel tank cap.

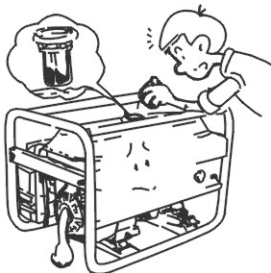

2. Check the fuel level if the fuel level is low.

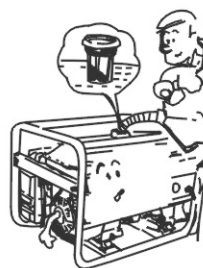

3. Add the unleaded gasoline to the shoulder of the filter screen.

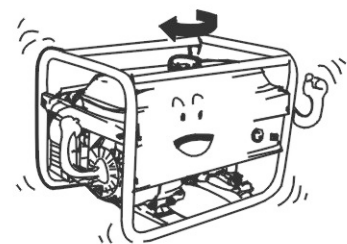

4. Install the fuel tank cap.

**Warranty and Service Questions ?
Missing or Damaged parts
Call 866 797 2738**



4. ENGINE AIR CLEANER

1. Unsnap the air cleaner cover springs, and remove the air cleaner cover
2. Check the air cleaner element to be sure it is clean and in good condition.

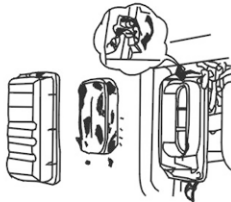

3. If it is dirty, remove and clean the element.

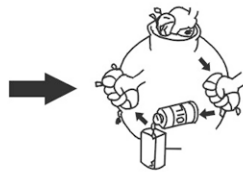

- (1) Wash in solvent
- (2) Squeeze
- (3) Soak oil
- (4) Squeeze dry

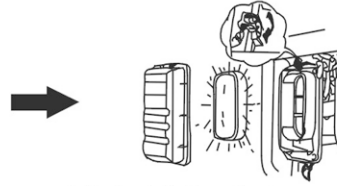

4. Reinstall the air cleaner element and secure the cover by setting the cover spring.

5. AIR COMPRESSOR AIR CLEANER

1. Unscrew the air cleaner from the pump head by turning the air cleaner counter clockwise.
2. Separate the filter body into two halves.
3. If the air cleaner element needs cleaning blow it out with air. Replace air cleaner assembly if unsure whether element can be cleaned sufficiently.
4. Reconnect the halves of the air cleaner body.
5. Screw the air cleaner into the pump head by turning clockwise until the air cleaner is hand tight.

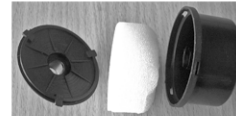
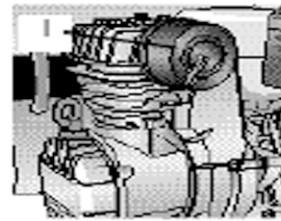

5. STARTING THE ENGINE

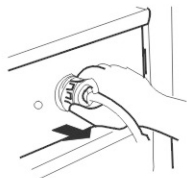

1. Disconnect any load from the AC receptacle, and turn the AC circuit breaker OFF

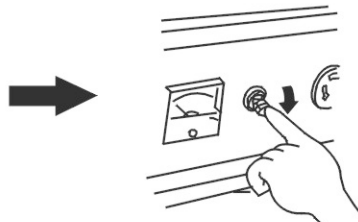

2. Turn the AC circuit breaker to the "OFF" position.

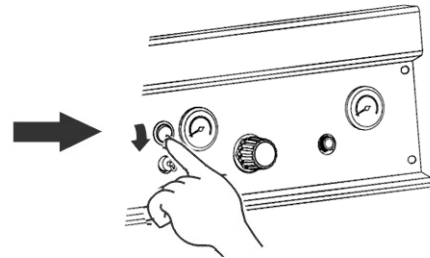

3. Turn the air compressor switch to the "OFF" position

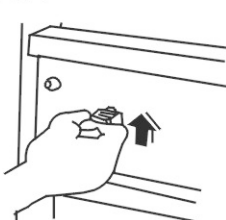

6. Turn the engine switch to the "ON" position.

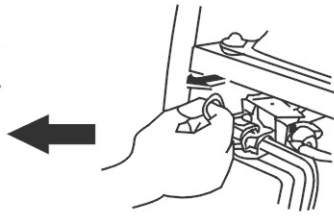

5. Pull the choke rod out to the "CLOSED" position. Check the air cleaner element to be sure it is clean.

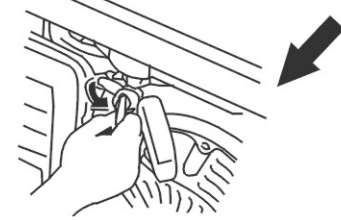

4. Turn the fuel valve to the "ON" position.

**Warranty and Service Questions ?
Missing or Damaged parts
Call 866 797 2738**

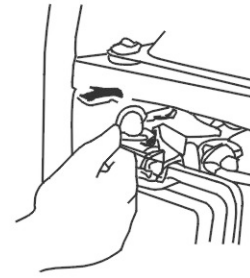
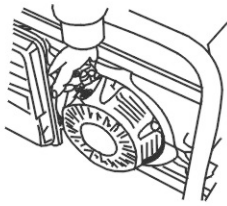

6. Pull the starter grip lightly until resistance is felt then pull briskly.

Warning: Do not allow the starter grip to snap back against the engine. Return it gently.

7. Push the choke rod to the " OPEN " position as the engine warms up.

6. GENERATOR USE







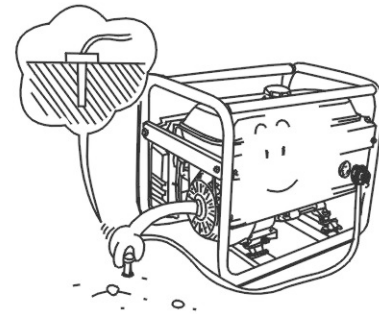

- To keep the generator always in top mechanical and electrical condition, observe the following:

⚠ WARNING

1. To prevent electrical shock from faulty appliances, the generator should be grounded.

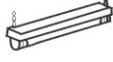

2. Combined load of the connected apparatus must not exceed the rated capacity of the generator. Electric apparatus, particularly motor-driven equipment, will draw a higher current when starting. The following table is provided for your reference when connecting such apparatus to your generator.

TYPE	WATTAGE		TYPICAL APPARATUS	EXAMPLE		
	STARTING	RATED		APPARATUS	STARTING	RATED
Incandescent lamp Heating appliance	X1	X1	Incandescent lamp 	Incandescent lamp 	100VA (W)	100VA (W)
			TV 	100W		
Fluorescent lamp	X2	X1.5	 Fluorescent lamp	 40W Fluorescent lamp	80VA (W)	60VA (W)
Motor driven equipment	X3~5	X2	 Refrigerator  Electric fan	Refrigerator  150W	450~750VA (W)	300VA (W)

Connect a copper wire to the generator and the other end to a metal stake driven into the ground

**Warranty and Service Questions ?
Missing or Damaged parts
Call 866 797 2738**

3. When two or more pieces of apparatus are connected to your generator, turn them on beginning with the one drawing higher current when starting.

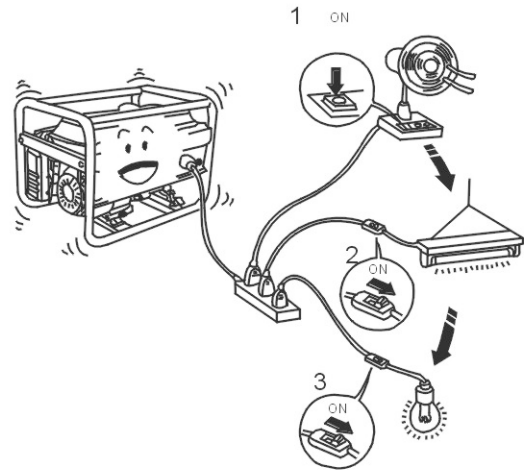

Note:

1. When connecting the generator to the household power supply, have it connected by people who have good knowledge of electricity.
2. After connecting apparatus to your generator, check that it is connected properly. Failure to connect properly can result in a damaged generator or fire hazard or personal injury.

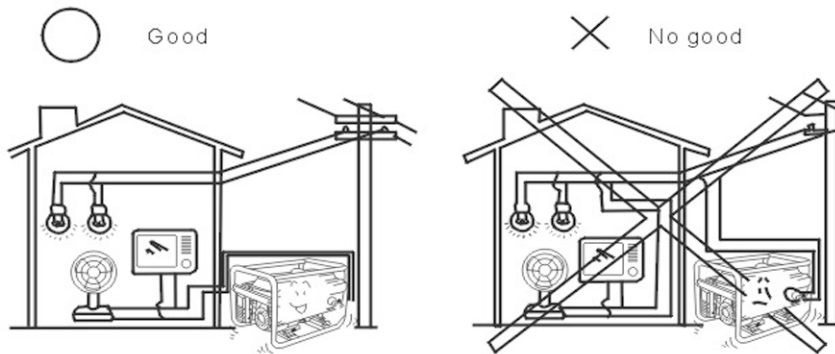

AC APPLICATION

1. Start the engine.
2. Make sure that the needle of the voltmeter indicates the voltage.

3. Plug in the appliance

Note: a: Overcurrent will automatically turn off the AC breaker.
When that is turned off, the generator shall be restarted with load reduced a few minutes thereafter.
B: Generally 5% tolerance of output is allowed.

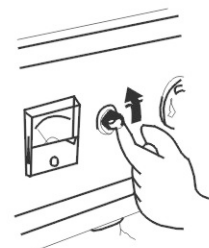
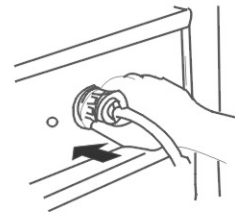

**Warranty and Service Questions ?
Missing or Damaged parts
Call 866 797 2738**

DC APPLICATION

The DC terminals may be used for charging 12V automotive-type batteries only

1. Connect the charging cables to the battery terminal.
2. Start the engine and charge the battery

NOTE: An overloaded DC circuit will trip the DC circuit breaker (push button comes out)

If this happens, check the short circuit or counter connection and wait a few minutes before pushing the circuit protector.

3. Stop the engine, then disconnect the charging cables in the reverse order of connection.

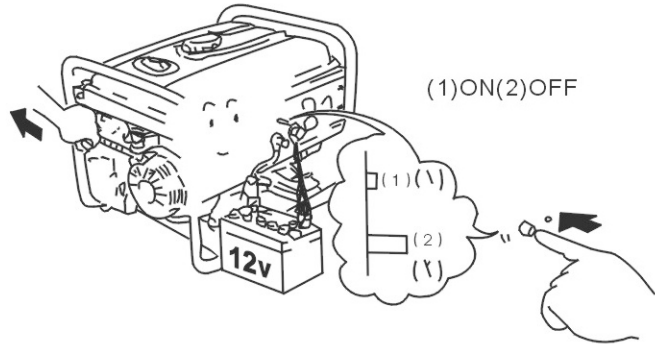
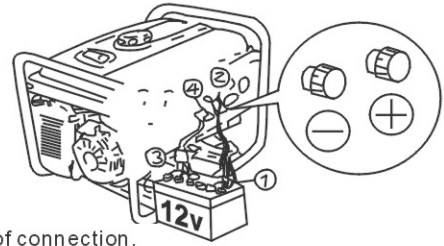

7. AIR COMPRESSOR USE

COUPLER USE

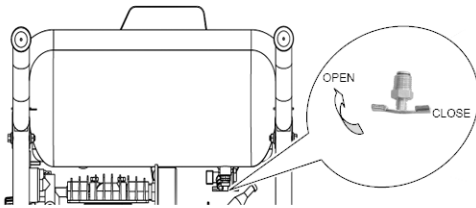

1. Turn the air tank's drain valve in a clockwise direction to close the tank.

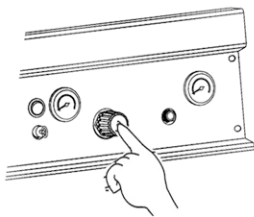

3. Adjust the regulator to the working pressure of the tool.

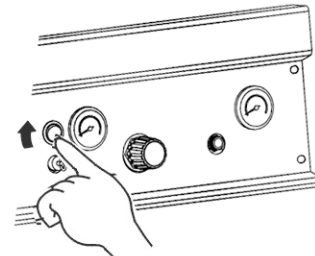

2. Start the engine, then turn the air compressor switch to the "ON" position.

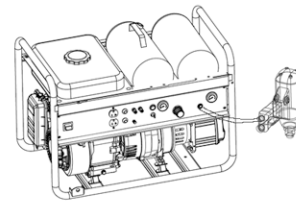

4. Connect the air tool to the coupler.

WARNING: The pump and manifold generate high temperatures. To prevent burns or other injuries, DO NOT touch the air compressor while it is running. Allow the air compressor to cool before handling or servicing. Keep children away from the air compressor at all times.

WARNING: When adjusting from a higher to a lower pressure, turn the knob counterclockwise past the desired setting. Next, turn the knob clockwise to reach the desired pressure. Do not exceed the operating pressure of the tool or the accessory being used.

**Warranty and Service Questions ?
Missing or Damaged parts
Call 866 797 2738**

PORTABLE AIR TANK USE

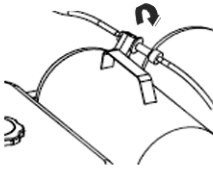

1. Turn the portable air tank's make up valve to the "OFF" position.

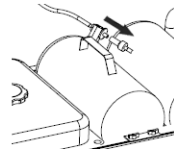

2. Disconnect the inlet pipe.

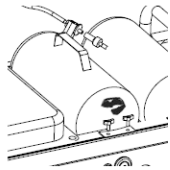

3. Unscrew the papilionaceous nut.

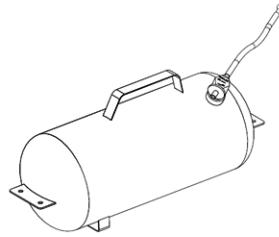

4. Turn on the make up valve, then you can use the portable air tank charge the tyre or other wheels.

8.STOPPING THE ENGINE

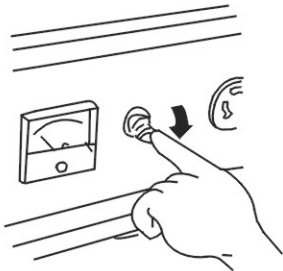

1. Turn AC circuit breaker to the " OFF " position.

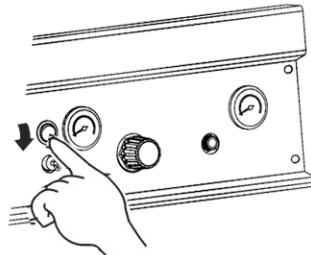

2. Turn the air compressor's switch to the "OFF" position.

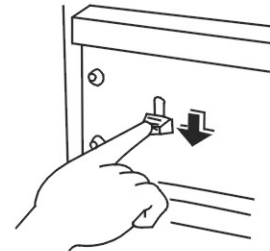

3. Turn the engine switch to the " OFF " position.



4. Disnnect the electrical appliance.

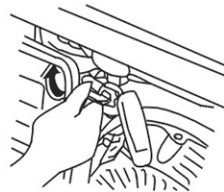

5. Turn the fuel valve to the " OFF " position.

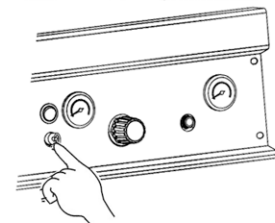

6. Reduce pressure in the tank through the outlet hose. You can also pull the relief valve ring, and keep it open to relieve pressure in the tank.

NOTE: To stop the engine in an emergency, turn the engine switch OFF.

































CAUTION: Escaping air and moisture can propel debris that may cause eye injury. Wear safety goggles when opening petcock.

**Warranty and Service Questions ?
Missing or Damaged parts
Call 866 797 2738**

9. MAINTENANCE

-  Check
-  Change
-  Clean
-  Check-Readjust

(1): These items should be serviced by a dealer.
 (2): Every 3 years

			 First month or	 Every 3 months or	 Every 6 months or	 Every year or	SEE page
Engine oil							P.4
							P.15
Air compressor oil							P.6
Air cleaner							P.6
							P.6
Air compressor cleaner							P.6
Fuel strainer							P.16
Relief valve							—
Spark plug							P.16
Valve Clearance						 ⁽¹⁾	—
Combustion Chamber						 ⁽¹⁾	—
Fuel line				 ^{(1), (2)}			—

1. ENGINE OIL CHANGE

1. Remove the oil filler cap.
2. Remove the drain plug and drain the oil.
3. Dispose of oil properly.

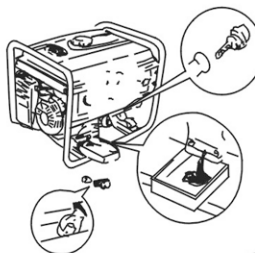

4. Install the drain plug and tighten it securely.
5. Refill with the motor oil (see 4 page) and check the oil level

ENGINE OIL CAPACITY: 20 oz (.6 Liter)

6. Install the oil filler cap.

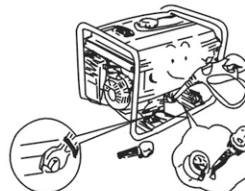

Recommended oil: 4-stroke motor oil service classification SJ, SL, SG or SAE10w-30 for general temperature

**Warranty and Service Questions ?
 Missing or Damaged parts
 Call 866 797 2738**

- 2. AIR CLEANER (See 6 page)
- 3. SPARK PLUG

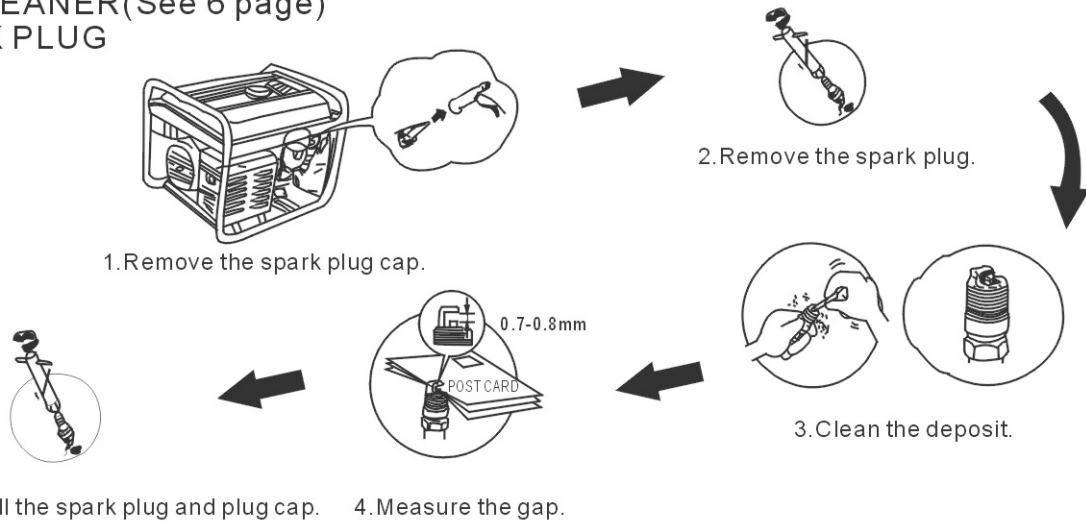

4. FUEL STRAINER

1. Turn the fuel valve to the OFF position and remove the sediment cup and filter screen.



2. Clean the sediment cup and fuel filter screen.



3. Install the fuel filter screen and sediment cup.

5. DRAIN THE AIR TANK

WARNING: Condensation will accumulate in the air tank. To prevent corrosion, this moisture must be drained at the end of every workday. Be sure to wear protective eyewear. Relieve the air pressure in the system and open the petcock on the bottom of the air tank to drain.

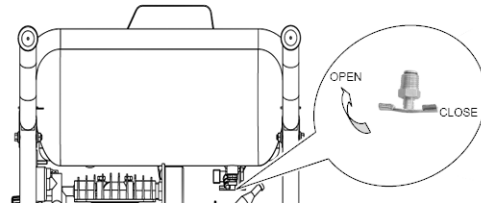

NOTE: In cold climates drain the air tank after each use to reduce problems with freezing water.

6. CHECK THE RELIEF VALVE

Pull the relief valve daily to ensure that it is operating properly and to clear the valve of any possible obstructions.

7. CHECK THE AIR COMPRESSOR'S OIL LEVEL (SEE PAGE)

NOTE: The oil should be replaced after the unit has run for 50 hours. Use non-detergent, SAE 30W oil.

8. CLEANING THE COMPRESSOR'S AIR CLEANER

Clear compressor's air cleaner monthly at a minimum dependent upon usage and environmental concerns such as dust and dirt.

9. TEST FOR LEAKS

Check that all connections are tight. A small leak in any of the hoses or pipe connections will substantially reduce the performance of your air compressor. If you suspect a leak, spray a small amount of soapy water around the area of the suspected leak with a spray bottle. If bubbles appear, tighten or replace the faulty component. Do not overtighten any connections.

**Warranty and Service Questions ?
Missing or Damaged parts
Call 866 797 2738**

10. STORAGE

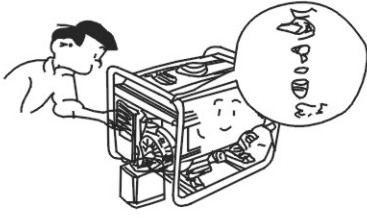

1. Close the fuel valve, drain the fuel from the fuel tank.

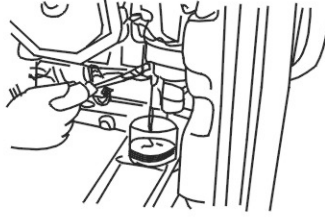

2. Drain the fuel from the carburetor.

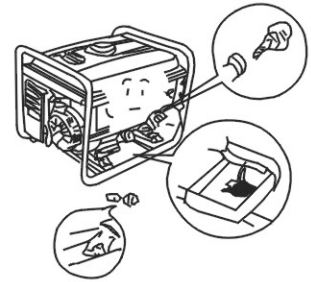

3. Remove the oil filler cap and drain plug to drain the oil.

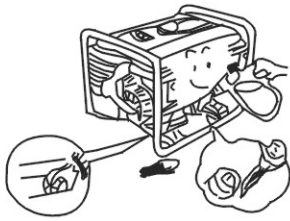

4. Tighten the oil drain plug and fill the engine with new oil to the filler neck.

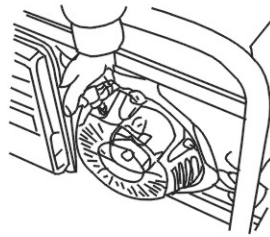

5. Pull the starter grip carefully until resistance is felt.

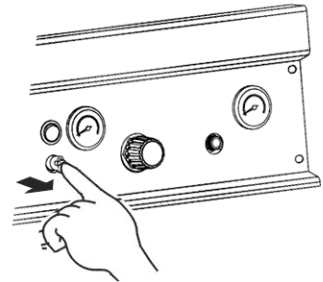

6. Pull the pressure relief valve to release all pressure from the tank.

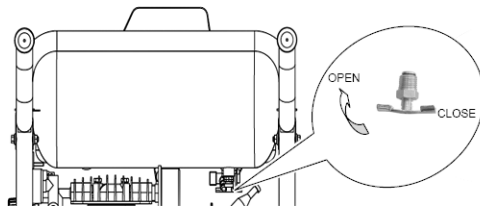

7. Drain all moisture from the air tank.

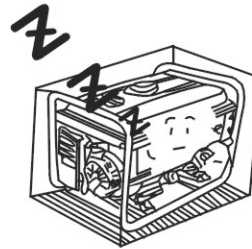

8. Store the generator in a clean area.

11. TROUBLE SHOOTING

ENGINE DOES NOT START:

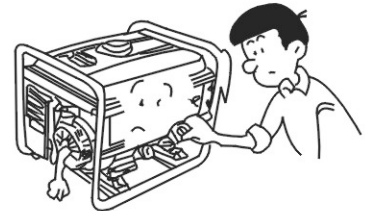

1. Turn on the engine switch.

2. Check fuel.

3. Check oil.

Warranty and Service Questions ?
Missing or Damaged parts
Call 866 797 2738

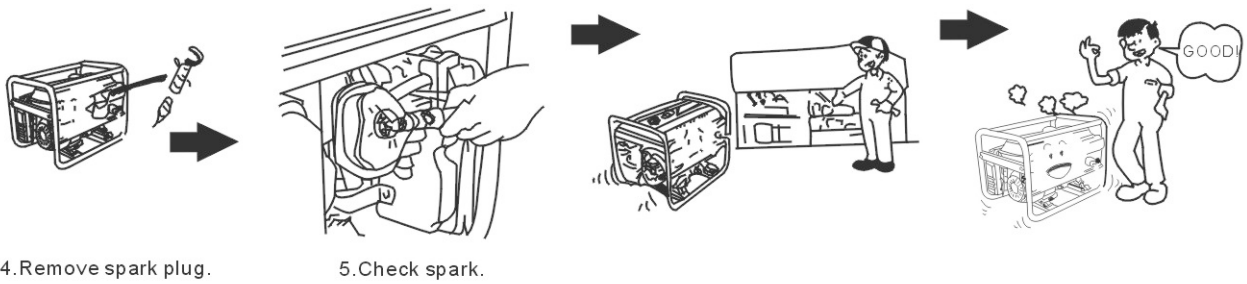

4.Remove spark plug.

5.Check spark.

NO ELECTRICITY:

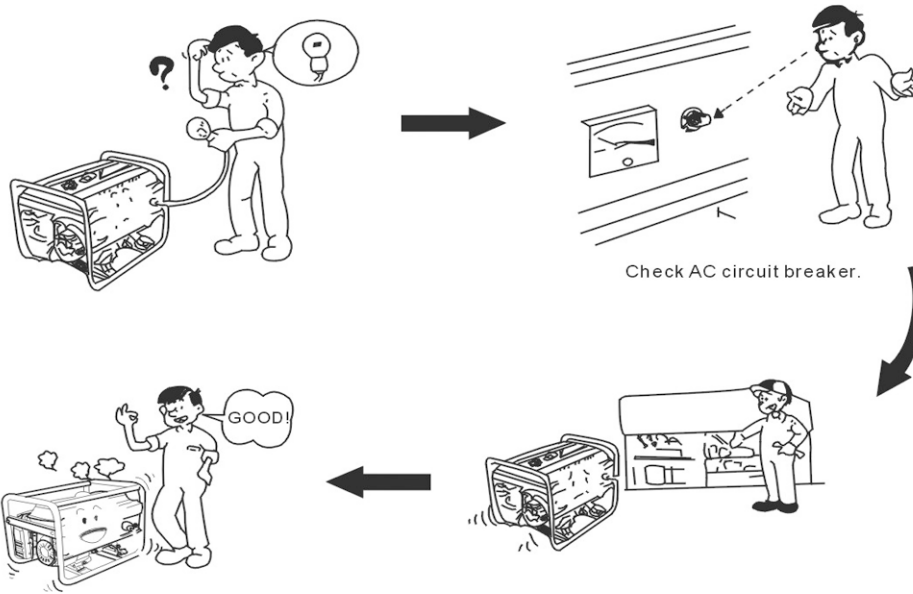

Check AC circuit breaker.

AIR COMPRESSOR CAN NOT RUN

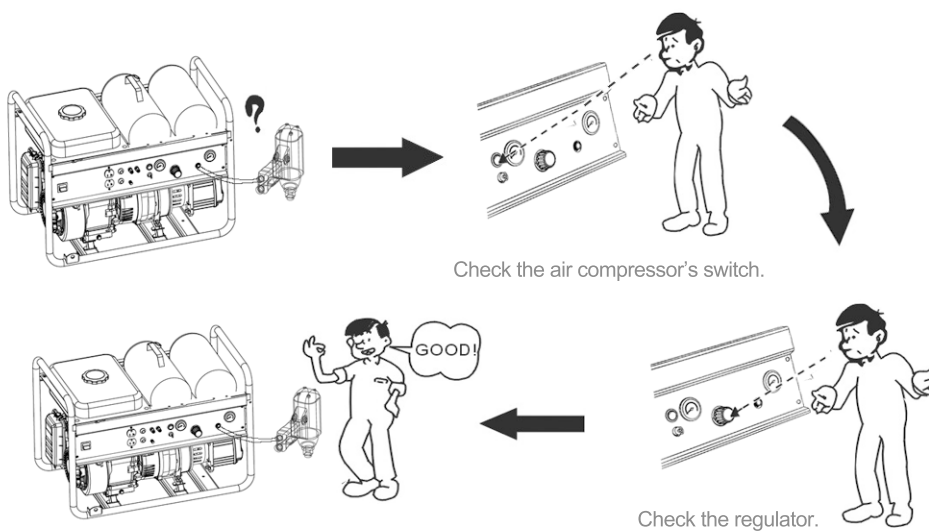

Check the air compressor's switch.

Check the regulator.

**Warranty and Service Questions ?
Missing or Damaged parts
Call 866 797 2738**

12. WIRING DIAGRAM

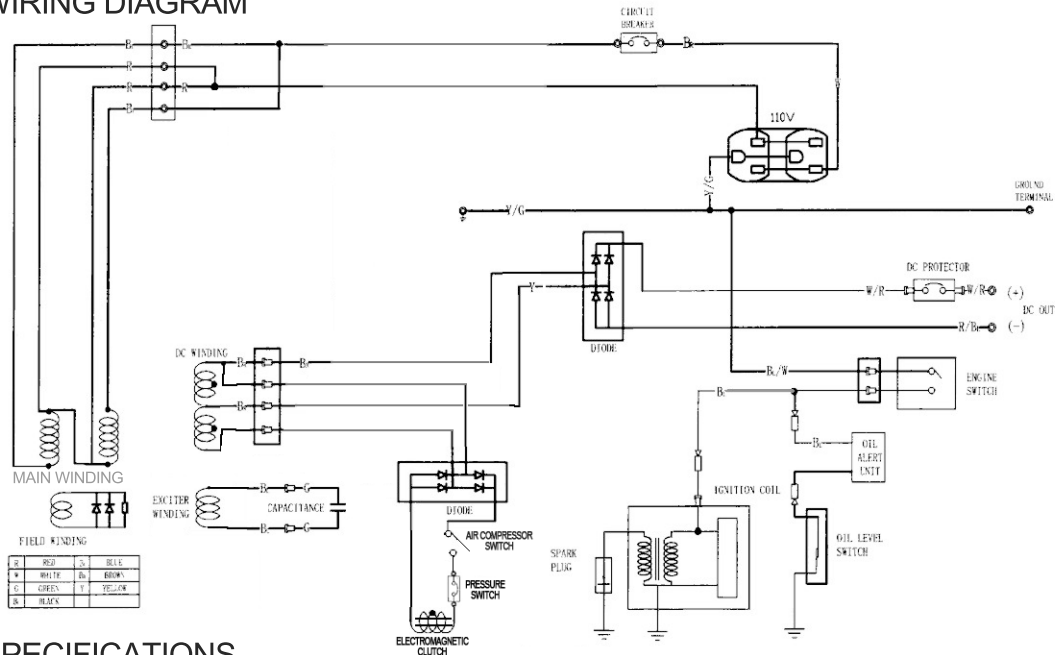

13. SPECIFICATIONS

Package(LxWxH) (in)	29.13x17.72x21.02(740x450x530mm)
Net weight (lbs)	2714.(55.5kg)
Model	ACG4-2800
Type	Single phase, brushless
Rated voltage (V)	120
Rated frequency (Hz)	60
Rated current (A)	16.7
Rated power (kW)	2.0
Max. power (kW)	2.3
Power factor (cos (φ))	1.0
DC rated voltage (V)	12
DC rated current (A)	10
Air delivery	4.0CFM@40PSI~2.6CFM@90PSI
Safety device	N.F.B
Engine	JF168FLH-2
Type	Air-cooled single cylinder.4-stroke engine
Bore x stroke (in)	2.68X2.12(68mmX54mm)
Output MAX. (Hp/rpm)	6.5/3600
Start mode	Recoil start
Operation time (hr)	10
Ignition system	TCI
Fuel type	Unleaded gasoline
Oil type	SAE10W-30/SAE10W-40

Note: specifications subject to change without prior notice.

Warranty and Service Questions ?

Missing or Damaged parts

Call 866 797 2738

14. PART ASSEMBLY

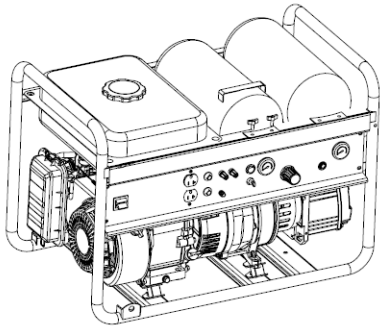

1. Unscrew the papilionaceous nuts

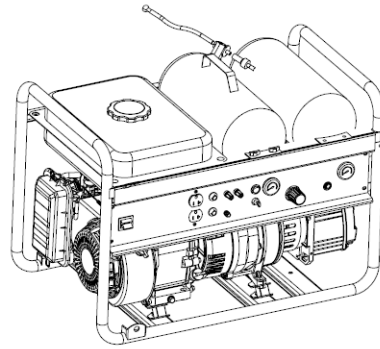

2. turn over the portable air tank,
than screw the papilionaceous nuts.

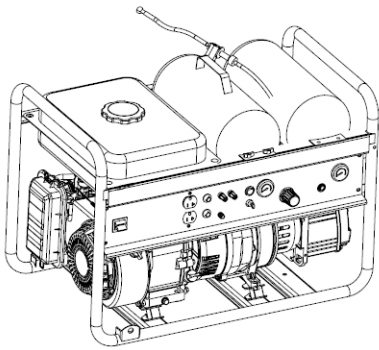

3. Connect the inlet pipe.

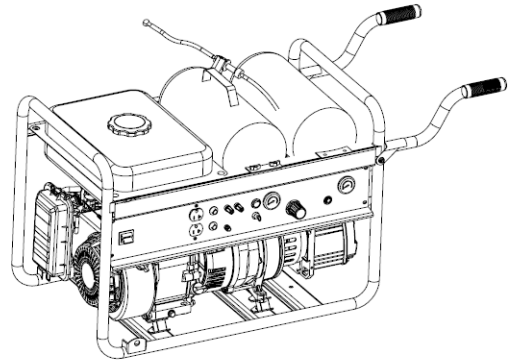

4. Assembly the handles.

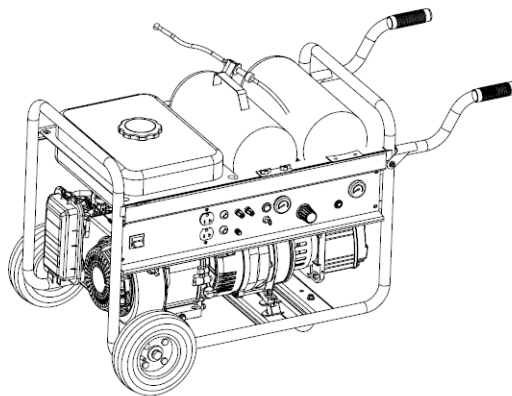

5. Assembly the wheels and planket.

**Warranty and Service Questions ?
Missing or Damaged parts
Call 866 797 2738**