



## **NorTrac 35XTD**

### **Owner's Manual**

Sold By

Northern Tool + Equipment, Co..

P.O. Box 1299

Burnsville, MN 55337

Tel.: 1-800-521-0438

[www.nortrac.com](http://www.nortrac.com)

[www.northerntool.com](http://www.northerntool.com)

**Copyright 2016 Northern Tool + Equipment Co.**

# NorTrac 35XTD Crawler Dozers – ROPS/FOPS equipped models

Information in this manual applies to item #s;  
24549, 245491

## Product Identification Data Sheet (to be completed by owner)

Product Item Number	
Product Model	NorTrac 35XTD Crawler
Dozer Serial Number	
Engine Model	
Engine Serial Number	
Date of Purchase	
Owner Name	
<b>All SNs in this form should be recorded completely (including letters).</b>	



**Dozer  
Nameplate  
Information**

**Engine  
Nameplate**



Distributed exclusively by  
Northern Tool + Equipment Co., Inc.  
Burnsville, MN 55306-6936  
Made in China

**Copyright © 2013-2016 Northern Tool + Equipment Co.**

**All Rights Reserved**

# Table of Contents

---

## Table of Contents

NorTrac™ LIMITED WARRANTY .....	1
Introduction .....	3
Using Your Owner’s Manual .....	3
Disclaimer.....	3
Special Messages.....	4
1. Safety Precautions .....	5
1.1 Safety Rules and Notices of Use .....	5
1.1.1 Preparatory Precautions .....	5
1.1.2 Operating Precautions .....	8
1.1.3 Driving Precautions .....	13
1.1.4 Parking Precautions .....	14
1.1.5 Storage Precautions .....	14
1.1.6 Maintenance Precautions.....	15
1.1.7 Battery Precautions.....	18
1.2 Safety Warning Symbols.....	19
1.2.1 Machine Safety Labels .....	19
1.3 Preventing Farm Machine Hazards.....	22
2. Operating Instructions .....	25
2.1 NorTrac Assembly, Setup, and Break-in.....	25
2.1.1 NorTrac Assembly, Setup, and Test .....	25
2.1.2 New Machine (Initial Owner) Run-in.....	26
2.1.3 Initial Run-In (10 Hour) Service.....	27
2.1.4 Daily Operating Checklist.....	28
2.1.5 Fuel, Lubricants and Coolant/Anti-Freeze .....	28
2.1.6 Controls and Instruments .....	30
2.1.7 Safety Precautions While Driving and Operating .....	32
2.2 Operating the Dozer.....	33
2.2.1 Preparing to Start the Engine .....	33
2.2.2 Starting the Engine .....	33

# Table of Contents

---

2.2.3 Unique Steering Characteristics of a Dozer .....	34
2.2.4 Driving the Dozer .....	35
2.3 Working Systems, Implements and Attachments.....	37
2.3.1 Six-Way Blade .....	37
2.3.2 3-Point Hitch System.....	38
2.3.3 Power Take-Off (PTO) .....	40
3. Electrical System .....	41
3.1 General.....	41
3.1.1 Battery .....	42
3.1.2 Fuse Box.....	42
3.1.3 Alternator and Voltage Regulator .....	42
3.1.4 Starter .....	43
4. Service .....	44
4.1 Service Intervals.....	44
4.1.1 General Maintenance.....	44
4.1.2 Fuel System Maintenance.....	48
4.2 Fluid and Lubricant Servicing .....	48
4.2.1 Fill and Drain Instructions .....	49
4.3 Engine Servicing .....	50
4.3.1 Valve Clearance.....	51
4.3.2 Fuel Injection Timing .....	51
4.3.3 Fuel Injector Troubleshooting and Replacement.....	52
4.3.4 Injection Pump.....	53
4.3.5 Engine Oil Pressure .....	53
4.4 Driveline Servicing .....	54
4.4.1 Clutch.....	54
4.4.2 Gearbox and Main Drive .....	55
4.4.3 Brake and Steering Clutch Mechanism .....	56
4.4.4 Track Tension Adjustment Procedure.....	57
4.4.5 Hydraulic System.....	58
4.5 Electrical Servicing.....	58

# Table of Contents

---

4.5.1 Battery Maintenance.....	58
4.5.2 Using Booster Cables to Jump-Start.....	59
4.6 Storage and Startup after Storage .....	59
4.6.1 Preparing Dozer for Long-Term Storage .....	59
4.6.2 Startup after Long-Term Storage .....	60
5. Diagnostics .....	61
5.1 Engine.....	61
5.2 Driveline .....	64
5.3 Electrical System .....	66
6. Dimensions and Specifications .....	68
6.1 Overall Machine Design Information and Specifications .....	68
6.2 Crawler Bolt Torque Specification .....	71
6.3 Engine Parts - Fitted Clearances and Wear Limits .....	71

# **WARRANTY**

## **NorTrac™ LIMITED WARRANTY**

### **4WD Diesel Tractor & Compact Crawler / Bulldozer**

NorTrac™ equipment is sold by NorTrac; a division of Northern Tool & Equipment Company, Inc. (NTE). NorTrac™ will repair or replace, at its option, any part(s) thereof of the NorTrac™ 4WD diesel tractor or crawler / bulldozer that are shown to be defective in material and/or workmanship, under normal use during the applicable 24 month warranty period. NorTrac wants your equipment to operate well and will assist you on repairs.

**All warranty repairs submitted after the first 60 days of ownership are subject to a \$100.00 labor deductible, per covered repair.**

After the labor deductible has been met, all warranty repairs and replacements will be made without charge for parts or labor at a pre-authorized service center. All parts replaced as a result of this limited warranty become the property of NorTrac and must be returned to NTE upon request. All parts replaced will become a portion of the whole and will be warranted for the duration of the original equipment warranty.

### **Length of Warranty**

The limited warranty begins on the original date of purchase and extends to 24 months for consumer household use.

For the commercial end user, the limited warranty is in effect for 6 months (180) days from date of original purchase.

- Commercial use is defined as: intended for the purpose of monetary reward or gain through the loan, rental or hire of equipment - OR- any manner that is primarily intended for or directed toward commercial advantage “For Profit” or private monetary compensation, or use by any governmental agency.

### **Qualifications for the limited warranty:**

- Applies to the original purchaser of the equipment. The limited warranty is non-transferable.
- Owner is to provide proof of purchase.
- Equipment was purchased in the United States from authorized representatives of NorTrac and/or NTE, Company, Inc.

### **To obtain service:**

Contact NorTrac Warranty Administrator by calling 1-800-521-0438 to report a possible warranty issue and to receive repair authorization from the Warranty Administrator. Detailed failure information can also be provided in hard-copy written form along with contact information to the address listed at the bottom of this page.

After receiving authorization from NorTrac Warranty Administrator, and the address of the pre-authorized service center, take the equipment to the service center during their regular business hours.

**All transportation costs after the first 60 days of ownership are the responsibility of the equipment owner.**

### **Exclusions and Warranty Disclaimers:**

This limited warranty applies to equipment used in its original form. Any unauthorized modifications or any incorporation or use of unsuitable attachments or parts will automatically void this limited warranty.

This limited warranty does not include parts affected or damaged by accident and/or collision, normal wear & tear (light bulbs, filters, belts, motor brushes, brakes, fuses and switches, tires and tubes, clutch linings, engine tune up, wheel alignment and lubrication), fuel contamination, or from failure to follow instructions contained in the User Manual for the equipment.

Warranty is void if adjustments are made to the injection pump fuel delivery system, starting fluid or ether is used to start or

# **WARRANTY**

run the engine or regular maintenance and service is not performed as prescribed by the operator's manual during the warranty term. The cost of normal maintenance of the equipment is the responsibility of the owner.

## **Limited Warranty**

This limited warranty does not cover defects that result from accident, misuse, lack of maintenance, improper repairs, neglect or use of replacement parts and accessories which do not meet NorTrac specifications.

## **Disclaimer of Consequential Damage:**

Any implied warranty of merchantability or fitness for a particular purpose, to the extent that either may apply to any NorTrac<sup>™</sup> tractor or crawler / bulldozer, shall be limited in duration to the periods of the express warranties shown above, and to the extent permitted by law any and all implied warranties are excluded. In no event will NorTrac or NTE Company, Inc. be liable for any loss of income, loss of time or use of the product, transportation, hiring of alternative services, commercial loss or any other incidental, consequential, or special damages and / or expenses. Some states do not allow limitations on how long an implied warranty lasts and / or do not allow the exclusion or limitation of incidental or consequential damages, so the above exclusions and limitations may not apply to you. This limited warranty gives you specific legal rights which may vary from state to state.

## **NorTrac**

### **C.O Warranty Administrator - Warranty Information**

**2800 Southcross Drive West — PO Box 1219**

**Burnsville, MN 55337**

# User Notes

## Thank You

Thank you for purchasing a NorTrac dozer from Northern Tool + Equipment Company. We value you as a customer and want you to enjoy many years of satisfaction and safe use of your dozer.

**Please contact NorTrac at 1-800-521-0438 for technical, parts and warranty assistance.**

## Introduction

The 35XTD crawler/bulldozer is powered by a fuel-efficient, 4-cylinder diesel engine and has a versatile manual transmission with eight forward and two reverse speeds. With a Category 1 rear hitch and 540/720 RPM PTO, the dozer can be used with such implements as a backhoe, post hole digger, cultivator, or log splitter. The six-way blade has a 20-inch lift that can dig down to three inches.

## Using Your Owner's Manual

- This Owner's Manual is an important part of your dozer and should remain with the dozer if you sell it. Please keep it in a safe, dry place.
- Failure to follow the break-in procedures will shorten the life of your dozer and void the warranty on the dozer.
- Read this Owner's Manual to help you and others avoid personal injury or damage to the dozer.
- This manual provides information on the safest and most effective use of the dozer. It will help you and others you might train to operate the dozer safely and correctly.
- If you use the dozer with an implement or other attachment, use the safety and operating instructions in the owner's manual for that implement or attachment along with this Owner's Manual so you can operate the implement safely and correctly with the dozer.
- While the dozer shown in this manual may differ slightly from your specific dozer model, the instructions in this manual will apply to your machine unless otherwise stated.

## Disclaimer

The 35XTD dozer and its components may be changed by the manufacturer at any time without notice and may not correspond to the contents of this Owner's Manual.

# User Notes

## Special Messages

Before operating this crawler/bulldozer, please read this manual carefully. Pay particular attention to the safety precautions on the following pages as well as those noted throughout this manual. Please read all such precautions carefully to avoid injury and machine damage.

This manual describes safety precautions as well as break-in procedures, proper usage, technical maintenance, adjustment, faults and troubleshooting methods for various parts of the NorTrac XTD dozers. The manual gives an in-depth look and should be used as a reference tool for owners and maintenance personnel.

The **Safety Alert Symbol**  ( ) identifies important safety messages in this manual and on machine safety labels on the dozer (see *Machine Safety Labels* in the *Safety* chapter). This Safety Alert Symbol is used to draw your attention to potential safety hazards and machine damage.

**Please call 1-800-521-0438 with questions or to obtain clarification of material in this manual.**

There are three levels of potential hazard, from least to most serious, as shown in these examples:

1. “**Caution**” alerts you to actions that could result in minor injury or could damage the dozer or its implements and thus result in possible safety hazards.



**CAUTION!** Inspect the machine before you operate and make any necessary adjustments!

2. “**Warning**” alerts you to safety hazards that could result in serious injury or even death.



**WARNING!** To avoid tipping, drive up and down slopes, not across them!

3. “**Danger**” alerts you to safety hazards that could result in serious injury or death, but is restricted to the most serious hazards or those that could occur suddenly or with little warning.



**DANGER!** Explosive Gases could cause blindness or other serious injury. Wear protective eyewear!

In addition, some government regulations specify that no one under the age of 16 may be employed to operate power machinery. (Refer to U.S. Department of Labor, Employment Standards Administration, Wage and Hour Division, Child Labor Bulletin #102)

In employment conditions, current OSHA regulations state in part: “At the time of initial assignment and at least annually thereafter, the employer shall instruct every employee in the safe operation and servicing of all equipment with which the employee is, or will be, involved.”

Observe the accident prevention rules as well as other safety regulations and local traffic rules at all times. The manufacturer is not liable for any damage to the machine or personal injury resulting from any unauthorized refitting of this machine or use of the dozer for tasks that are outside the scope of the dozers usage guidelines.

# Safety Precautions

---

## 1. Safety Precautions

### 1.1 Safety Rules and Notices of Use

**IMPORTANT!** Read this section thoroughly before attempting to drive the crawler/bulldozer.

This section points out some of the basic safety precautions and warning identifiers that may apply during the normal operation and maintenance of the dozer. See also the *Safety Precautions While Driving and Operating* sub-section under *Operating Instructions* later in this Owner's Manual.

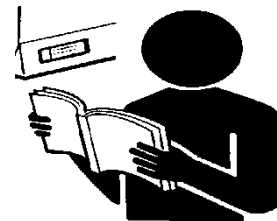

Additional precautions may be necessary, depending on the implements or attachments used and the conditions of the worksite or service area. Other information that can affect the safe operation of the dozer may be contained on safety signs, in vocational-agricultural and extension training materials, or in insurance requirements, employer's safety programs, safety codes, local, state/provincial, and federal laws, rules, and regulations.

It is YOUR responsibility to read and understand these safety precautions before operating the dozer. Remember that you are the key to safety. Study this manual. Study the owner's manuals for any implements or attachments you are using with the dozer. Make these safety precautions a working part of your safety program and practice all other usual and customary safe working precautions.

#### **1.1.1 Preparatory Precautions**

**Safe use of the 35XTD crawler / dozer requires the operator to be knowledgeable in the machine operation. When preparing to operate the dozer, read this sub-section and take note of the precautions listed below:**

#### **Protect Yourself**

- During operation, the driver should avoid loose-fitting and bulky clothing, jewelry or other items that could catch on parts of the dozer.
- Wear reflective clothing, a hard hat, safety shoes, heavy gloves, and safety glasses or goggles.
- Use hearing protection, foul weather gear, and a filter mask as appropriate.
- Have a first-aid kit available
- Always have a fire extinguisher available.

#### **Know the Dozer**

**Be familiar with the dozer and check it regularly. This includes the following measures:**

- Know the purpose of the controls, gauges, and dials. (See *Controls and Instruments* in the *Operating Instructions* section of this owner's manual.)
- Know the rated load capacity and speed range. (See the *Specifications* section of this owner's manual)
- Be familiar with braking and steering characteristics, turning radius, and operating clearances. (See the *Specifications* section of this owner's manual.)
- Recognize that rain, snow, ice, soft ground, gravel, sand, and other conditions affect the dozer operation.
- Be prepared to slow down and be extra careful under poor conditions.
- Be familiar with the dozer's machine safety labels. (See this owner's manual *Machine Safety Labels* section)

**Do not modify or remove parts of the dozer.**

# Safety Precautions

---

## Check the Dozer

Before operating the dozer, ensure all systems are in proper working condition; including the items listed below: In addition, check the hydraulic and cooling systems, as explained in the following sections.

- Perform maintenance items described under *Service Intervals* in the *Service* section of this Owner's Manual.
- Check for loose, broken, missing, or damaged parts.
- Check the tracks for proper tension and check the fasteners on the drive sprocket.
- Check the engine oil level and coolant level for the cooling system. (See below.)
- Check the fuel level and verify that the inlet valve for the fuel filter bowl is open.
- Check all hydraulic lines for signs of leakage.
- Check to ensure the dozer's lights are operating.
- Check the brakes.
- Check the rollover protection structure (ROPS) and seat belt for damage.
- When using a power take-off (PTO) attachment, ensure that the PTO drive locking device is latched and the PTO shield is in place. **Failure to do so may result in personal injury and severe damage to the implement and the dozer clutch and drivetrain.**
- Verify that the dozer and implement PTO RPM ratings (540 and 720) match.
- Make sure that implements and attachments are properly installed.
- Check the hydraulic systems of the dozer and any implements. (See below.)
- Make sure all safety devices are in place and working.

If problems are found, take appropriate measures to correct them.

## Checking the Hydraulic System

- Before disconnecting hydraulic lines to check the hydraulic system, be certain to relieve system pressure.
- Before re-applying pressure to the system, ensure that all connections are tight and that pipes, lines, and hoses are not damaged. See the Warning below.



### Warning!

- Hydraulic oil or diesel fuel that is under pressure can penetrate skin or eyes causing serious injury, blindness or death.
- Under pressure, fluid leaks may not be visible. To find leaks, use a piece of cardboard or wood. Never use your bare hands and wear safety goggles for eye protection.
- If any hydraulic oil or diesel fuel is injected into your skin, seek immediate medical attention from a doctor familiar with this type of injury to have the fluid or fuel removed.

## Checking the Cooling System

Take the following precautions when checking the cooling system:



### Warning!

- When the engine is hot, the cooling system is under pressure.
- Stop the engine and allow the system cool before removing the radiator cap.

# Safety Precautions

---

- Antifreeze/coolant should always be used in the engine cooling system.
- Do not fill the radiator with cold water or splash the radiator or engine with cold water when the engine is hot. After the engine is cool, antifreeze/coolant can be added to the radiator with the engine running.
- When cleaning the radiator, shut down the dozer and allow to cool.

## Keep the Dozer Clean

**Keep the engine and work surfaces clean. Take measures such as these:**

- Clean the dozer after first lowering the blade and any implements to the ground, placing the gear shift lever in 1st gear, shutting off the engine, and removing the key.
- Clean the lights.
- Clean the floor, steps, pedals, control levers, and engine compartment by removing grease and oil, and brushing dust or mud away (and—in cold weather—ice and snow).
- Clear away any dirt, straw, or other debris from the tracks and the radiator's scraper.
- Make sure that the foot pedals are clear of all obstacles and able to move freely to their home position.
  
- Never store items on the floor or around the pedals that could limit pedal travel.
- Remove loose items such as ropes, chains, hooks, tools, and lunch boxes.

## Inspect the Work Area

**Inspect the area where you will be working or traveling. Take measures such as these:**

- Look for ditches, drop-offs, steep slopes, potholes, stumps, and standing water.
- Check for other conditions that might be hazardous.
- Remove foreign objects or debris in the path of the dozer.

**Check for overhead clearance, especially when using implements!**



### **Warning!**

- **Contact with overhead powerlines can kill or seriously injure.**
- **Before starting work, inspect the work and travel area; then determine the safest procedure.**

## Re-fuel Carefully

- Before refueling, turn off the engine and allow it to cool.
- Do not overfill the tank or spill fuel. If you do spill fuel, clean it up immediately.
- Use No. 1 or No. 2 diesel fuel when ambient temperatures are above 50° F (10° C) (summer).
- Use only No. 1 diesel fuel when ambient temperatures are below 50° F (10° C) (winter).
- Ground the fuel funnel or nozzle against the filler neck to prevent sparks.
- Be sure to replace the fuel tank cap.

# Safety Precautions

---

## **1.1.2 Operating Precautions**

Before operating the 35XTD crawler-bulldozer read this sub-section and take precautions as listed below:

### **Know General Operating Rules**

- General operating rules for the dozer include taking measures like these:
- Securely fasten your seat belt.
- Reduce speed on rough, slick, muddy, or unstable surfaces or when crossing slopes or turning.
- Avoid use of the dozer near holes, ditches, and embankments whenever possible. Pay close attention to the surroundings, especially on roads, around trees, or when turning.
- Do not allow others to ride on the dozer.
- Do not allow children or unqualified persons to operate the dozer.
- Stay off of slopes too steep for safe operation.
- Operate the dozer smoothly— avoid sudden or jerky turns, starts, stops or changes in direction.
- Place the gear shift lever in 1st gear when the dozer is stopped.
- Hitch only to the specified drawbar and hitch points.
- Before crossing or going under a bridge, through a tunnel or into a structure, ensure adequate clearance and that the load and ROPS height are within the limits of the structure.
- Never leave the driver's seat while starting or operating the dozer.
- Always operate the dozer in a safe and responsible manner to avoid injury and possible death.
- If the dozer is being operated on multiple shifts in a work environment, be sure to tell the next shift about any problems with the dozer.
- Disengage the PTO, lower the blade and any implements and attachments to the ground, place the gear shift lever in 1st gear, shut off the engine, and remove the key before dismounting.



### **Warning!**

**When operating the dozer, do not use alcohol or drugs that can affect your alertness or coordination.  
When using prescription medications, consult your physician regarding the safe operation of machinery.**



### **Warning!**

**When operating the dozer, keep all parts of your body inside the operator's compartment at all times.  
Do not reach through, touch, or lean on any implement mechanism or permit other to do so.**



### **Warning!**

**Stay alert! If any part or component becomes loose or broken or fails to operate correctly, stop work, stop the engine and make appropriate repairs or adjustments before resuming operations.**

# Safety Precautions

---

## Mount and Dismount Safely

- Before using the dozer, walk completely around it to ensure that no persons or objects are on, under, or close to the dozer and any implements or hitched equipment.
- When mounting or dismounting the dozer, do so carefully, always keeping three of your four arms and legs in contact with the dozer.
- Watch for slippery steps and keep your hands and feet away from any controls.
- Never jump onto or off of the dozer.
- Face the dozer when mounting or dismounting.
- Never mount or dismount from the dozer when it is moving.
- Advise anyone nearby that you are starting the dozer.
- Do not start until everyone is clear of the dozer and any implements or hitched equipment.

**If necessary to dismount when the dozer is running; place the gearshift in neutral and set the parking brake.**

## Start Safely

- Adjust the operator's seat, fasten the seat belt, and place the dozer gearshift in neutral before starting.



### Warning!

**Only start the engine when sitting in the driver's seat.**

**Never try to start the engine by shorting across starter terminals. Doing so will bypass the clutch safety switch (which requires the clutch to be depressed to start the engine): allowing the engine to start with the transmission in gear, causing the dozer to move suddenly, and could cause serious injury or death!**

- Follow the starting procedures described under *Preparing to Start the Engine* and *Starting the Engine* in the *Operating Instructions* section in this Owner's Manual.
- Check all gauges, instruments, and indicator lights.



### Warning!

**Never use ether or other starting fluids on this dozer!**

**In addition to being highly flammable; the use of starting fluids is not recommended as it can cause permanent engine damage that is not covered under warranty.**

**Please refer to the *Operating Instructions* section of this Owner's Manual under *Fuel, Lubricants, Coolant / Anti-Freeze***

- Make sure there is adequate ventilation when starting the dozer in an enclosed space.



### Warning!

**Exhaust fumes contain carbon monoxide and other pollutants that can kill.**

# Safety Precautions

---

## Test Controls

- After starting the dozer, recheck all gauges, instruments, and indicator lights and verify that the readings are within normal operating range.
- Make sure all controls are working correctly, including brakes, clutch, hydraulic controls, and gear shift.
- If the dozer does not respond correctly to any of the controls, do not use the dozer until the problem is corrected.



### Warning!

- **Ensure that you can control the dozer's speed and direction before driving.**
- **Move slowly until you are certain that all systems are operating correctly.**
- **Check steering in both directions and ensure you have full control over steering and braking.**

## Watch for Others

- Be alert to what is going on around the dozer.
- Keep others away from the dozer.
- Do not let anyone stand on the dozer's tracks.
- Never drive towards a person who is standing in front of a fixed structure, object, or piece of equipment.
- Be familiar with all pinch and wrap points on your equipment.
- Keep others away from the PTO, hitches, and other moving parts.
- Keep all shields and guards in place.



### Warning!

- **Never allow riders on the dozer; it is a one-person machine.**
- **Never allow anyone to ride on any implements or attachments to the dozer.**
- **Never allow children to ride on the dozer or in the lap of the operator.**



### Warning!

**Never stand, or allow anyone else to stand between the dozer and an implement unless;**

- **The engine is stopped,**
- **The gear shift lever is in 1<sup>st</sup> gear**
- **All attachments and implements are lowered to the ground.**



### Warning!

**Never use an implement to lift a load over a person.**

# Safety Precautions

---

## Avoid Overturns

Take these precautions to avoid side and rear overturns:

### Side Overturns

Listed below are precautions to avoid side overturns:

- Reduce speed to match operating conditions.
- Turn with wide slow turns at reduced speeds.
- Do not use the brakes on one side to make a sharp turn.
- Go slow over rough terrain to avoid bouncing the dozer.
- Avoid braking suddenly. Instead, apply brakes gradually and smoothly.
- Shift into gear before starting down a slope.



**Never disengage the clutch or attempt to shift gears AFTER beginning to travel downhill!**

- Travel straight up or down, rather than across, a steep slope. If it is necessary to travel across a slope, avoid holes and depressions on the downhill side and raised areas, rocks, bumps, or stumps on the uphill side.
- When crossing a steep slope, avoid turning uphill. If you must do so, slow down and make a wide turn.
- When traveling down-slope, use the throttle to slow the dozer, using the same gear range used to go up-slope.
- Avoid riverbanks, ditches, and embankments, as well as their edges, which can cave in or shear away.
- Lock the drawbar in the center position when towing a load at transport speed.
- Avoid pulling loads that are too heavy for the dozer. They can run away from the dozer on a down slope or cause the dozer to jackknife around the load.
- Avoid raising any attached implement or the blade when crossing a slope.

### Rear Overturns

Listed below are precautions to avoid rear overturns:

- Attach towed loads to the drawbar only.



### **Warning!**

**Attaching a towed load to the rear axle or other point above the drawbar can cause a rear overturn!**

- Start slowly, gradually increasing your speed.
- Do not rev the engine or suddenly release the clutch pedal.
- Do not attempt to drive forward if the dozer is mired in mud or frozen to the ground. Instead, raise any attached implement and attempt to back out. If this is not possible, tow the dozer out with another vehicle.
- If the dozer is stuck in a ditch, back-out. If you must go forward, do so slowly and carefully. If the front end of the dozer starts to lift, reduce speed and disengage the clutch, if necessary.
- Travel directly up or down a slope, never across it.
- When traveling up or down a slope, keep the heavy end of the dozer pointed uphill. For example, a bare dozer or one with a rear-mounted implement should be backed up a slope in reverse and should travel forward downhill.
- Stay off of steep slopes.
- Keep the dozer in gear and the clutch engaged when going downhill.

# Safety Precautions

---

## Hitch, Unhitch, and Operate Implements Properly

- Hitch towed loads **ONLY** to the drawbar.
- When attaching or detaching a three-point mounted implement, refer to the implement's instructions and to *Operating the Hydraulic Hitch System* in the *Operating Instructions* section of this Owner's Manual.



### Warning!

**Do not allow anyone to stand between the dozer and an implement or other attachment while backing the dozer up to connect.**

- To prevent unexpected movement, place the hydraulic power lift (3-point hitch) selector lever in the lowered position before attaching the implement.
- Before unhitching an implement, move to a level area and lower the implement to the ground or block the equipment in place.
- If a PTO connection is required, refer to the implement's instructions and the *Operating the Power Take-Off (PTO)* in the *Operating Instructions* section of this Owner's Manual.
- Use all safety locks, safety chains, pins, and shields required.
- Be sure all PTO shields and implement driveline safety devices are in place and working properly.



### Warning!

**PTO wrapping or entanglement will result in severe injury or death. Do not approach a PTO driveline unless it is disengaged and has stopped rotating. Stay clear of all rotating components.**

The dozer is designed to operate with many different types of implements, attachments, and equipment. Each has its own operating characteristics and hazards. Many specialized implements have very specific operating hazards. You are responsible for familiarizing yourself with the operating instructions and warnings pertaining to each specific dozer/implement combination. Consult the implement manufacturer's manuals as well as *Operating Implements and Attachments* under *Operating Instructions* in this Owner's Manual.

## Watch for Hazards

**Take these precautions against possible hazards while operating the dozer:**

- Be sure everyone is clear of the dozer and any implements before engaging the PTO.
- For stationary PTO operation, always place the gear shift lever in neutral, set the parking brake and block both dozer tracks and implement wheels.
- When operating mobile PTO-driven equipment, never leave the dozer operator's seat until the PTO drive is disengaged, the gear shift lever is in 1st gear, the engine is shut off, and the key is removed.



### Warning!

**Never try to unclog or adjust an implement with the engine running or the PTO drive in operation; Serious injury or death may result!**

- When operating under poor visibility instructions or in the dark, use the dozer lights and reduce your ground speed. Do not use the rear-facing work lights when traveling on a roadway to avoid blinding and confusing drivers behind you.

# Safety Precautions

---

- Three-point hitches and side-mounted implements make a much wider arc when turning than towed equipment. Be careful to maintain sufficient clearance for safe turning.
- Do not overload an attachment or towed equipment.
- Reduce your speed when operating over rough or slippery terrain or when foliage restricts your view of possible hazards and obstacles.

## **1.1.3 Driving Precautions**

**Read this section and take precautions listed below before attempting to operate the dozer:**



### **Warning!**

- **Read and understand the operation sections of this Owner's Manual before operating the dozer.**
- **To avoid tipping, drive up and down slopes – NOT across them.**
- **Drive slowly on slopes and be careful when changing direction**
- **Avoid changing gears while driving on a slope.**
- **If you must back down a slope, disengage any implement and back down slowly.**



### **Danger!**

- **Look behind and around the dozer before and while backing up.**
- **Never allow children or any other riders on the dozer or any implements.**
- **Keep children out of the working area and remain alert.**
- **Never carry children in a trailer attached to the dozer**
- **Never allow children or any untrained persons to operate the dozer**
- **Use extra caution when approaching shrubbery or other objects that can block your view.**



### **Caution!**

- Never wear headphones when operating the dozer
- Wear appropriate clothing, work gloves, sturdy shoes and safety equipment such as earplugs and protective eyewear.
- Ensure that all operators are physically capable of operating the dozer safely and are able to pay proper attention to possible safety hazards.
- Never operate any kind of heavy equipment when tired or under the influence of alcohol or drugs.
- Be advised that any type of medication may impair your ability to effectively and safely operate this machine; check with your physician before operating the dozer.



### **Caution!**

- Follow the instructions under *Operating the Dozer* in the *Operating Instructions* section of this Owner's Manual before using the dozer for normal operations.
- Inspect the dozer and make any necessary adjustments before operation.
- Always repair or replace parts promptly if damaged, badly worn, or missing.
- If the dozer or its implement hits an object; stop, inspect the machine and make any necessary repairs before continuing.

# Safety Precautions

- Stop the dozer if any person approaches while it is operating.
- Never leave the dozer unattended if the engine is running.
- Never rest your foot on the clutch pedal except when changing gears
- Never stop the dozer with brake pedals only; always use the clutch and brake pedals simultaneously
- Always operate the dozer in daylight or with all headlights and running lights operating properly.



## Warning!

- Obey all local traffic laws.
- When driving on public roadways, use proper warning lights; slow-moving vehicles are more difficult for other drivers to see especially at night.
- Slow-moving vehicles that normally travel at a maximum speed of less than 25 mph must display the sign shown at the right. Consult local laws to determine if this is required in your area.
- Do not apply the brakes in a sudden manner; slow steady foot pressure is recommended.
- Never turn the dozer in either direction while traveling at a high rate of speed; overturning, injury and damage can result.
- Do not allow any riders on the dozer or any towed equipment, implements or attachments.



## Shut Down the Dozer Properly

When shutting down the 35XTD crawler/bulldozer, be familiar with *Stopping the Dozer* under *Operating the Dozer* in the *Operating Instructions* section in this Owner's Manual.

Moving parts that are covered by shields may rotate for several minutes after the dozer is shut down.

To avoid bodily injury, watch and listen for signs of continued rotation.

Do not open or remove any shields until all components have stopped.

### 1.1.4 Parking Precautions

When shutting down the 35XTD crawler/bulldozer, be familiar with *Stopping the Dozer* under *Operating the Dozer* in the *Operating Instructions* section in this owner's manual. In addition, take these precautions:



## Warning!

**Before dismounting the dozer, always place the gearshift lever in 1<sup>st</sup> gear, stop the engine and remove the keys to avoid accidental start up and to keep the dozer from moving while unattended.**



## Caution!

- Always park the dozer on firm level ground to prevent tipping.
- If parking on a slope is necessary, position the machine at a right angle to the slope and block the tracks.
- Disengage the PTO and lower any attachments to the ground.
- Do not leave the driver's seat until the engine and all parts have stopped moving.

### 1.1.5 Storage Precautions

When storing the dozer, take these precautions:

# Safety Precautions



## Warning!

- Allow the engine and exhaust system to cool before storing the dozer in an enclosed area.
- Store the dozer with the blade and any attached implement lowered to the ground and release all stored hydraulic pressure by actuating the control levers.
- Never store the dozer inside a building with fuel in its tank if fumes from the fuel could reach an open flame or spark.
- If the engine must be run in a confined area, provide adequate ventilation. Use an exhaust pipe extension if necessary.



## Caution!

- Remove the battery if the dozer will be stored without use for an extended period of time.
- Store the battery in a cool dry location where it will not freeze.
- Store out of the reach of children.

### 1.1.6 Maintenance Precautions

Read the sub-section before doing maintenance or repair on the dozer and take the precautions listed below:

#### Take Basic Maintenance Precautions

Listed below are basic maintenance precautions:



## Danger!

- Keep hands, feet, clothing, jewelry and long hair away from any moving parts.
- Do not approach a PTO driveline unless it is disengaged and has stopped rotating.
- PTO wrapping or entanglement will result in serious injury or death.
- Stay clear of all rotating components!



## Warning!

- Keep all safety devices in place and in proper working condition
- If any components must be raised or removed for servicing, support them.
- Before servicing electrical system or welding on the dozer, disconnect negative cable from the battery.



## Warning!

- Never attempt to service the dozer while it is moving.
- Lower all implements to the ground, place gearshift lever in 1<sup>st</sup> gear, stop the engine and remove key.
- Allow engine to cool.
- If the engine must be run while servicing, ensure gearshift is in neutral and parking brake is set.
- Ensure adequate ventilation is provided. Use an exhaust pipe extension if necessary.

**Exhaust fumes can kill!**

# Safety Precautions

---



## Warning!

- If the Roll-Over Protection System (ROPS) is damaged, it must be replaced.
- Never modify or repair the ROPS by drilling, cutting or welding as this may compromise its integrity.



## Caution!

- Never attempt to service the dozer or its implements unless you are a skilled, trained mechanic.
- Study the *Servicing* sections of this Owner's Manual before attempting any service procedures.
- Keep the service area clean and dry.
- Never modify the dozer or implements except as authorized by NorTrac or Northern Tool + Equipment Co.
- Never wear headphones when servicing.
- Wear appropriate clothing and avoid loose fitting clothing.
- Use appropriate safety equipment including ear and eye protection.
- Keep all parts of the dozer and implements in good working condition and properly installed.
- Always repair or replace parts promptly if damaged, badly worn or missing.
- Check frequently for any loose fasteners.
- Keep the dozer and implements clean; remove oil or grease deposits and any debris.

Check the *Battery Precautions* later in the *Dozer Safety Precautions* sub-section.

## Prepare the Dozer

If the dozer is disabled, fasten a **Do Not Operate!** tag to the front handle bar, and remove the ignition key if the dozer should not be started.



## Warning!

Only start the engine when sitting in the driver's seat.

Never try to start the engine by shorting across starter terminals. Doing so will bypass the clutch safety switch (which requires the clutch to be depressed to start the engine); allowing the engine to start with the transmission in gear, causing the dozer to move suddenly, and could cause serious injury or death!

- If necessary, move the machine to a level surface.
- Place the gearshift lever in 1st gear, shut off the engine
- Block all hydraulically operated attachments, and release all hydraulic pressure. (See *Stopping the Dozer* under *Operating the Dozer* in the *Operating Instructions* section in this Owner's Manual for further information.)

## Prepare the Work Area

- Ensure work area is clean, level and has enough clearance, room, and light. Make sure walking and work surfaces are clean. Remove grease, oil, and water to avoid slippery areas. Sand any existing slippery areas.
- Have the correct tools available and keep them clean.

# Safety Precautions

---

- Have jacks and hoists available and in good condition. Do not use jacks with bent, cracked, or twisted parts. Do not use twisted, frayed, or pinched cables. Do not use bent or distorted hooks. Always use wood blocks, jack stands, or other rigid and stable supports when working beneath raised equipment.



## Warning!

**Never use concrete blocks or damaged / decayed wood blocks for support. They can collapse even under light loads resulting serious injury or death!**

## Prepare Yourself

- Wear all protective clothing as appropriate for the maintenance tasks you will be performing.
- Wear a rubber apron and rubber gloves when working with corrosives.
- Wear gloves and safety shoes when handling wooden blocks or sharp-edged metal.
- Wear safety glasses or goggles to prevent eye injury due to electric arcs, fluids under pressure, and flying debris.
- Wear a face shield when disassembling spring-loaded components.
- Wear a helmet or goggles with special lenses when welding or using a cutting torch.
- Never wear a watch, ring, or loose clothing around machinery.
- Use mechanical assists and proper lifting methods to avoid back injuries.

## Avoid Fire and Explosion Hazards

- Shut off the engine and allow it to cool before filling the fuel tank.
- Always ground the fuel nozzle against the filler neck to avoid sparks.
- Avoid spilling fuel. If a spill occurs, wipe it up immediately.



## Warning!

**Never smoke while handling fuel or working on the fuel system. Be aware that the fumes in an empty fuel container or fuel tank are explosive. Never cut or weld fuel lines, tanks or containers.**

- Follow the manufacturers' procedures when handling solvents and dry chemicals.
- Work in a well-ventilated area.
- Make sure there are fire extinguishers nearby and know how to use them.
- Use only approved solvents to clean dozer parts. Never use diesel fuel.

## Handle Cooling Systems and Pressurized Fluids Properly

When maintaining the cooling and hydraulic systems, refer to *Checking the Hydraulic System* and *Checking the Cooling System* under *Check the Dozer* in the *Preparatory Precautions* sub-section earlier in this *Dozer Safety Precautions* sub-section.

## Check Machine Safety Labels

Clean or replace damaged, missing, or painted-over machine safety labels.

# Safety Precautions

---

## Do Not Take Chances or Exceed Safe Limits

- Use only parts, lubricants, and fluids described in this Owner's Manual.
- Use the correct tools. Make sure wrenches and drivers are properly fitted and avoid damaging machined and polished surfaces.
- During maintenance, inspect parts and replace them if cracked or damaged.
- Do not exceed the pressure limits of the fuel or hydraulic systems.

## Finalize Maintenance Properly

Before placing the dozer back into regular service, take these precautions:

- Tighten all bolts, fittings, and connections as specified under *Torque for Bolts and Nuts* in the *Engine Specifications* sub-section in the *Specifications* section later in this Owner's Manual.
- Reinstall all guards, covers, and shields after servicing, and replace or repair any damaged parts.
- Start the engine and check for leaks. If there are any hydraulic or coolant leaks, refer to *Checking the Hydraulic System* and *Checking the Cooling System* under *Check the Dozer* in the *Preparatory Precautions* sub-section earlier in this *Dozer Safety Precautions* sub-section.
- Operate all controls to ensure that the dozer and its implements are functioning properly. If necessary, road test the dozer. After testing, stop engine and re-check the work performed for missing cotter pins, washers, locknuts, etc. Re-check all fluid levels.

### 1.1.7 Battery Precautions

Follow these precautions when servicing the battery:



#### Warning!

- Explosive gases can cause blindness or other serious injury.
- Always wear protective eyewear and shield your eyes when servicing the battery.
- Ensure adequate ventilation when charging the battery.



#### Warning!

- Keep battery level (do no tip)
- Keep battery out of reach of children

Sulfuric acid can cause blindness and severe burns. In case of contact:

- Flush eyes immediately with water
- Get medical help immediately!



#### Warning!

When removing or installing battery:

- Keep sparks and open flames away and do not smoke
- Wear gloves and eye protection
- Never allow direct metal contact across battery posts
- When removing battery, disconnect negative cable first. When installing, connect positive cable first.

# Safety Precautions



## Warning!

When jump starting from a booster battery:

- Keep sparks and open flames away and do not smoke
- Wear gloves and eye protection
- Never try to jump start a frozen battery; warm to 60°F (15.5°C) first.
- Connect both ends of the red (+) cable first, beginning with the dead battery.
- Never connect the negative (-) jumper cable to the negative terminal of the dead battery; connect to a good ground location away from the battery.

## 1.2 Safety Warning Symbols

### 1.2.1 Machine Safety Labels



The dozer comes with machine safety labels placed in key areas to draw attention to potential safety hazards. Many of these machine safety labels use the words **DANGER**, **WARNING**, and **CAUTION** and the safety alert symbol explained under *Special Messages* in the *Introduction* to this Owner's Manual.

**DANGER** indicates the most serious hazards.





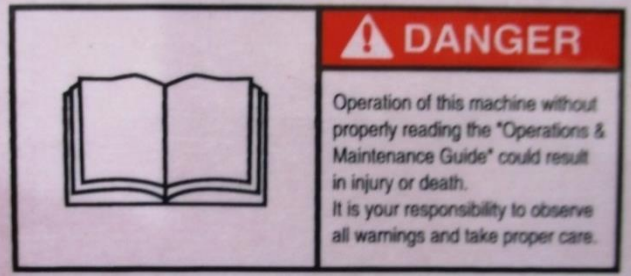

## Caution:





- All safety labels should be visible and easy to read. If they become obscured, wash with soapy water and wipe dry with a soft rag.
- If any safety labels are lost or damaged, contact NorTrac at 1-800-521-0438 for replacement stickers.
- When replacing parts with attached Safety warning symbols, the safety identifiers that correspond to that specific part need to be updated as well.
- To prevent injury, accidents and damage, always comply with safety warning labels.

Machine Safety Label	Description
	<p><b>Ensure Proper Usage</b></p> <p>Read and understand all instruction for use, including the meaning of all safety symbols.</p> <p><b>Location:</b> Left side of dash housing near stamped metal nameplate.</p>
	<p><b>Hydraulic System Under High Pressure</b></p> <ul style="list-style-type: none"> <li>• Remove system pressure before servicing or disconnecting lines or fittings.</li> <li>• Wear proper hand and eye protection.</li> <li>• Use cardboard or wood to locate leaks; do not use hands.</li> </ul> <p><b>Location(s):</b> Main hydraulic lift cylinders, top of right side compartment containing hydraulic controls &amp; valve.</p>

# Safety Precautions

 <p><b>WARNING</b> Entanglement and Dismemberment Hazard Keep hands and feet away from track when machine is in motion.</p>	<p><b>Entanglement and Dismemberment Hazard</b></p> <ul style="list-style-type: none"> <li>• Keep hands and feet away from track anytime machine is in motion.</li> </ul> <p><b>Location(s):</b> Sides of battery and hydraulic compartments</p>
 <p><b>WARNING</b> Avoid death or serious injury</p> <ol style="list-style-type: none"> <li>1. Before operating this machine read and understand the Operators Manual and the Equipment Manufacturer Institute Safety Manual.</li> <li>2. Operate all controls from the seat only.</li> <li>3. Before leaving seat: Park on level ground. Place Main and Auxillary Gear Shift in neutral. Stop engine by placing key in '0' Position. Lower blade or other implement to ground.</li> <li>4. DO NOT permit riders.</li> <li>5. DO NOT operate around children.</li> <li>6. Keep all safety shields and enclosures in place when operating this equipment.</li> </ol> <p>Contact Northern Tractor and Power for replacement manuals. 1-800-521-0438.</p>	<p><b>Pre-Operation Warnings – General Awareness</b></p> <ul style="list-style-type: none"> <li>• Read instructions before operating machine.</li> <li>• Remain in driver’s seat at all times when operating machine.</li> <li>• Parking &amp; Shutdown instructions.</li> <li>• Do not operate with others on or near machine.</li> <li>• Do not remove or defeat safety devices, shields or guards.</li> </ul> <p><b>Location(s):</b> Dash panel near key switch</p>
 <p><b>WARNING</b> Risk of Fall. On Entry &amp; Exit: • Maintain 3 points of contact • Never jump off machine • Climb up forwards, down backwards • Ensure the steps are clean</p>	<p><b>Risk of Fall</b></p> <ul style="list-style-type: none"> <li>• Maintain 3 points of contact when entering or exiting the machine</li> <li>• Never jump on or off</li> <li>• Keep steps clean</li> </ul> <p><b>Location(s):</b> Left side of dash housing.</p>
 <p><b>WARNING</b> DRIVER ONLY Strictly NO passengers.</p>	<p><b>This machine is designed for 1 person only.</b></p> <ul style="list-style-type: none"> <li>• Do NOT allow any person to ride on the fenders or any other place on the dozer.</li> <li>• Operating or riding in any location other than the driver seat could result in falling from the vehicle and possible severe injury or death.</li> </ul> <p><b>Location:</b> Right side of dash housing.</p>

# Safety Precautions

	<p><b>PTO Entanglement &amp; 3- Point Hitch Hazard</b></p> <ul style="list-style-type: none"> <li>• Do not remove any safety equipment or shields</li> <li>• Ensure driveline is securely attached at both ends</li> <li>• Do not operate PTO shaft at speeds above ratings for shaft or implement.</li> <li>• To prevent personal injury, please install the safety cover on the PTO shaft when it is not in use.</li> <li>• To avoid injury, stay a safe distance from the 3 point lift when it is in operation</li> </ul> <p><b>Location(s):</b> PTO safety shield</p>
	<p><b>Crushing Hazard</b></p> <ul style="list-style-type: none"> <li>• Do not remove any safety equipment or shields</li> </ul> <p><b>Location(s):</b> top of main blade lift cylinders</p>
	<p><b>Burn Hazard</b></p> <ul style="list-style-type: none"> <li>• During machine operation, keep a safe distance from hot surfaces, as they can cause serious burns.</li> </ul> <p><b>Location:</b> Side of engine compartment, near exhaust.</p>
	<p><b>Risk of Battery Explosion</b></p> <ul style="list-style-type: none"> <li>• Before servicing the battery, carefully read the instructions in order to understand the correct maintenance procedures.</li> </ul> <p><b>Location:</b> On top surface of the battery</p>
	<p><b>Be Aware of Your Surroundings</b></p> <ul style="list-style-type: none"> <li>• Please keep a safe distance from the machine when it is operating, to avoid any personal injuries.</li> </ul> <p><b>Location:</b> Rear of dozer on left side.</p>

# Safety Precautions

---

## 1.3 Preventing Farm Machine Hazards

*The following article describes important general safety precautions for machinery such as the NT-204C/NT-254 tractor. It is reprinted here with permission from Professor Thomas L. Bean, Safety Leader and Professor, Department of Food, Agricultural, and Biological Engineering, The Ohio State University Extension, The Ohio State University.*

**AEX-593-91**

**Thomas L. Bean**

Each year, 2,600 farm residents are killed and 230,000 disabled in farm-related injuries, many due to farm machinery. Farm machinery uses mechanical power to do work. This creates a number of possible hazards for both operators and bystanders. Even though manufacturers take many steps to make machinery safe, all hazards cannot be removed. Some machine parts cannot be completely shielded and still do their job. For instance, a totally enclosed cutting blade could not cut.

Many machinery-related accidents result from human error. The operator either forgot something, took a shortcut or a risk, ignored a warning, wasn't paying close attention, or failed to follow safety rules. In addition, guards removed for maintenance often aren't replaced.

There are many different kinds of farm machinery: mowers, tractors, shredders, harvesters, grinders, blowers, augers, balers, etc. They all have similar characteristics and hazards. You can be cut, crushed, pulled in or struck by an object thrown by these machines. They have cutting edges, gears, chains, revolving shafts, rotating blades, pinch points and other hazards. You can also be injured if you fall while working on or near any of these machines.

Accidents with farm machinery are often serious, even fatal. It is important to recognize and be alert for machine hazards and to take precautions to avoid injury.

### Shear and Cutting Points

Shear points (Fig. 1 below) are created when the edges of two objects are moved together closely enough to cut a soft material, as with a pair of shears or an auger. Cutting points are created when a single object moves forcefully or rapidly enough to cut, as with a rotary mower blade.

Both shear and cutting points are created on machinery designed to cut, such as harvesters, and on those that are not designed to cut, such as augers. They are hazardous because of their cutting force and they often move so rapidly that they may not be visible, so it is easy to forget they are operating or to underestimate the hazard.

Because some shear and cutting points cannot be guarded, it is important to be aware of their hazard and stay alert when they are operating. It is also important to warn others and to look out for their safety. This is especially true if there is a danger of thrown objects while using cutting-type equipment.

### Pinch Points

Pinch points are another hazard of farm machinery (Fig. 2 below). Pinch points (which should be more appropriately named mangled or maimed points) are formed when two rotating objects move together and at least one of them moves in a circle. For example, the point at which a belt runs into a pulley is a pinch point. Belt drives, chain drives, and gear drives are other sources of pinch points in power transmission devices. Feed rolls,

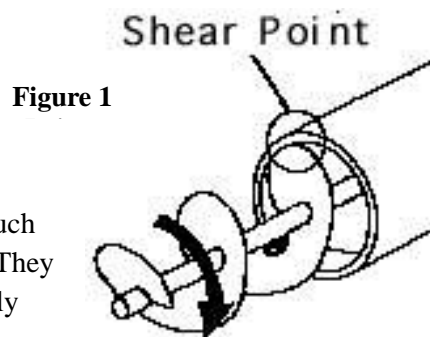

**Figure 1**

# Safety Precautions

gathering chains and similar equipment designed to draw crops into the machine also create pinch points.

Fingers, hands and feet can be caught directly in pinch points, or they may be drawn into the pinch points by the inertia of the moving part or loose clothing that becomes entangled. Contact may be made by falling or brushing against unshielded parts. You can become entangled in pinch points if you take chances and reach or work near rotating parts. Machines move too fast to get out of a pinch point once you become caught.

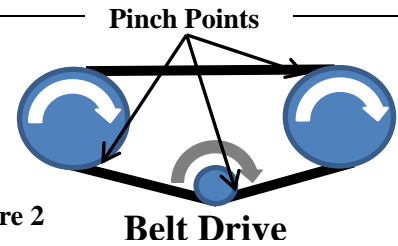

Figure 2

To avoid injury from pinch points, be aware where pinch points occur and avoid them. Wear clothing that fits well and is not loose or floppy. Never reach over or work near rotating parts. Turn off machinery to work on it. Always replace shields removed for maintenance.

## Wrap Points

Rotating shafts are the most common source of wrap-point accidents, although any exposed machine part that rotates can be a wrap point. A cuff, sleeve, pant leg, long hair or just a thread can catch a rotating part and result in serious injury. Entanglement with a wrap point can pull you into the machine, or clothing may become so tightly wrapped that you are crushed or suffocated. In other cases, you could be thrown off balance and fall into other machinery parts.

Even a perfectly round shaft can be hazardous if there is enough pressure to hold clothing against the shaft. Hazards increase with shafts that are not round. Clothing is more likely to catch if there is dried mud or manure on the shaft, or if the shaft is nicked. Ends of shafts that protrude beyond bearings are also dangerous. Universal joints, keys and fastening devices can also snag clothing.

Check all equipment for potential wrap points and, if possible, shield those that can be shielded. Replace any damaged manufacturer-installed warning labels and place warnings on equipment parts not previously labeled. In addition, consider painting them a bright color, perhaps with wide stripes. Be aware of wrap points and be alert to their danger.

## Crush Points

Crush points are created when two objects move toward each other or one object moves toward a stationary object. For example, hitching tractors to implements (Fig. 3 below) creates a potential crush point.

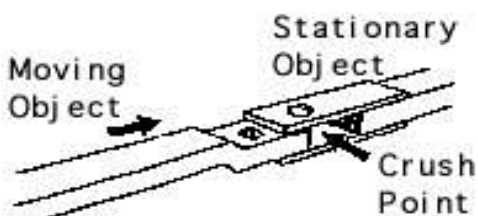

Figure

Hitch accidents most commonly occur to fingers placed at the hitching point. Wait until the tractor has stopped before stepping into the hitching position. If possible, arrange the hitch point so that the tractor can be backed into position without anyone between. Always know what the other person is doing.

Failure to safely block up equipment can result in a fatal crushing injury. A jack may slip, a hose or overhead support may break,

or the equipment may roll. Take extra precautions when working with machinery that is raised for any reason. The operator's head or chest can be crushed between the equipment and a low beam or other part of a farm building. These accidents usually occur when the machine is being operated in reverse. Tree limbs are also potential hazards when working with tractors and other machinery.

To prevent being crushed or pinned, recognize and avoid potentially dangerous situations. Block all machinery securely if you must work under it. If an implement can roll freely, block its wheels so it cannot roll.

# Safety Precautions

---

## Free-Wheeling Parts

Many machine parts continue to spin after the power is shut off, including cutter heads of forage harvesters, hammer mills of feed grinders, rotary mower blades, fans and flywheels. Never touch these parts until they have stopped moving. This could take 2 to 21/2 minutes.

## Springs



No Energy  
Spring Relaxed



Stored Energy  
Spring Compressed

Figure 4

Compressed springs (Fig. 4 below) will expand with great force when released, and springs that are stretched will contract rapidly when released. Know what direction a spring will move and how it might affect another machine part when released, and stay out of its path.

## Burn Points

Be aware of burn points: mufflers, manifolds and even gear cases under adverse climatic conditions. They may not be severe enough to seriously maim, but they can startle the operator enough to cause him or her to “jump” into more deadly danger.

## Hydraulic Systems

Hydraulic systems contain fluid under extreme pressure. Before loosening, tightening, removing or otherwise working with any fittings or parts, relieve this pressure. Jet streams from even pinhole leaks can penetrate flesh. In addition, the liquid is often hot.

Before attempting any service on hydraulic systems, shut off the engine that powers the hydraulic pump. Lower the implement to the ground and relieve the pressure. Follow instructions in the operator’s manual because the specific procedures for servicing the systems are very important to your safety.

*Funded in whole or in part from Grant Number U05/CCU506070-01, "Cooperative Agreement Program for Agricultural Health Promotion Systems," National Institute for Occupational Safety and Health.*

*Reviewed by Dr. Randall Wood and Dr. Warren Roller.*

# Operating Instructions

---

## 2. Operating Instructions

### 2.1 NorTrac Assembly, Setup, and Break-in

#### **IMPORTANT ISSUES:**

1. Always operate the dozer according to the specified break-in requirements. This will prolong the life of your dozer.
2. When using PTO-driven implements, the angle between the PTO shaft and the universal-joint drive shaft should be no more than 15°.
3. Place 3-point lift control lever in neutral when the implement is in the raised position.
4. When in the raised position, the included angle between the PTO shaft and the universal-joint drive shaft should be no more than 20°.
5. Failure to follow these guidelines may result in personal injury and severe damage to the implement and the dozer clutch and drivetrain.

**This section describes how to operate the 35XTD crawler/bulldozer. It covers these topics:**

- NorTrac assembly and break-in
- Initial owner break-in
- Daily operating checklist
- Fuel, lubricants, coolant/anti-freeze
- Controls and instruments
- Safety precautions while driving and operating
- Operating the dozer
- Electrical system
- Operating implements and attachments

#### **2.1.1 NorTrac Assembly, Setup, and Test**

**NorTrac performs final assembly, adjustment and detailed operational and performance testing of 35XTD dozer before shipping to ensure complete satisfaction and many years of trouble-free use.**

### **NorTrac Procedures**

**NorTrac's skilled technicians produce and prepare each unit, from start to finish, through a detailed process including:**

- Install blade frame, blade and related hydraulic components, ROPS/FOPS and 3-point hitch.
- Install hose heater, fill cooling system with anti-freeze/coolant and test to -35 F.
- Check fuel and hydraulic system retainers and lines.
- Drain factory fuel, replace with fresh diesel according to the season and add fuel conditioner.
- Inspect fuel delivery system, line routing and all connections.
- Check all lubricants to NorTrac specifications and proper fill level (engine, transmission, and hydraulic fluids).
- Check main clutch for proper engagement, free-play and smooth operation.
- Check and adjust linkages as needed for smooth operation and proper sequencing of steering clutches and brakes.
- Check and adjust throttle and fuel shut-off and parking brake linkages.

# Operating Instructions

---

- Start engine allow to warm-up; check throttle response throughout rpm range, monitor for smooth operation, vibration, proper oil pressure and thermostat operation.
- Perform electrical system function check.
- Test drive, operating engine throughout rpm range, to verify:
- Correct steering response and tracking of the steering system.
  - Proper drivetrain operation in all gears and ranges.
  - Parking brake operation and holding torque
  - Check overall dozer operation and gauge function.
- Verify proper function and adjustment of blade control, 3-point hitch system and PTO.
- Shut down engine and re-check
  - Cooling, fuel and hydraulic systems for leaks.
  - Re-confirm all fasteners in place and properly tightened.
  - Re-check fluid levels.
- Final clean-up and detailing for customer delivery.

## At Delivery

**You can be confident that every effort is made to make your new dozer is trouble free.**

**Upon delivery of the dozer, please confirm the following:**

- Machine is free from any shipping damage
- All items are present and in good condition (ignition and compartment door keys, manuals, parts, tools)
- Prior to operation, check coolant, engine oil, transmission oil, and hydraulic oil levels.

### **2.1.2 New Machine (Initial Owner) Run-in**

**When the dozer is first delivered (or after an overhaul), the initial break-in procedures described below must be performed to ensure proper operation, performance and life of the machine:**

#### **Initial Run-in**

**Perform this initial run-in for the dozer during the first 10 hours of operation:**

#### **Run the Engine**

Start engine and allow to run at idle speed; 600 rpm, for 10 Minutes. (See *Preparing to Start the Engine* and *Starting the Engine* under *Operating the Dozer* later in this section.

- After oil pressure and coolant temperature rise into normal operating range, increase the engine rpm gradually.
  - Monitor oil pressure; gauge should be steady and maintain a reading between 0.2 - 0.5 MPa.
  - Coolant temperature should reach steady state in the normal operating range on the gauge.
- Listen for any unusual engine noise.
- Observe the hour meter and ammeter for correct operation.
- Shut down engine and check for any fluid leaks.

#### **Operate 3-Point Hitch Hydraulic System**

- Connect an implement to the 3-point hitch to provide a load on the hydraulic system.
- Using the control handle, raise and lower the hydraulic 3-point hitch smoothly a minimum of 20 times over a period of 10 minutes with the engine at idle speed.

# Operating Instructions

- Observe the movement of the implement; confirm smooth operation during the raise-lower cycle.
- Do not allow the implement to drop too quickly and strike the ground or damage may occur.
- After cycling the 3-point hitch as described, lower the implement to the ground, shut down engine and check for any fluid leaks in the system.

## Drive the Dozer

Your dozer's initial run-in cycle has been completed by the factory per the table below.

- If you perform a complete overhaul of the engine or driveline, the initial run-in procedure should be repeated.
- Beginning with the dozer in low gears and the blade raised, operate on flat ground per the table below:

	Forward				Reverse
Gear:	1 Low	2 Low	3 Low	1 High	1 Low
Time	20	30	30	30	10

While driving the dozer at low speeds, practice turning left and right and using the brakes.

NorTrac Technicians have completed the following inspection steps after completing the dozer's final assembly and test, following the first two hours of factory run-in:

- Inspect and listen to the engine, the transmission, and the steering system.
- Make sure the clutch, brakes, and gears are operating normally.
- Check for correct readings on instruments and electrical equipment.



### Caution:

- To prevent damage, shut down the unit if any readings are out of range or abnormal engine or transmission sounds occur.
- Correct any abnormal conditions prior to continuing the break-in period.

## Increase Loads Gradually

You can begin using the dozer immediately upon receipt, per the run-in chart below:

	Forward			
Gear:	1 Low	2 Low	3 Low	1 High
Load (None; initial break-in)	-completed at factory-			
40% (1200 rpm max.)	3 Hours	4 Hours	5 Hours	5 Hours
60% (1500 rpm max.)	3 Hours	5 Hours	5 Hours	5 Hours
80% (1800 rpm max.)	3 Hours	5 Hours	5 Hours	0 Hours

- Gradually increase loads and speeds, changing gears periodically during the initial hours of operation. Do not apply heavy loads at the beginning.

**Initial Run-in Service must be performed after first 10 hours of operation.**

### 2.1.3 Initial Run-In (10 Hour) Service

After completing the initial 10-hour break-in period, perform the following:

- Change transmission fluid.
  - Remove plug and drain transmission case.

# Operating Instructions

---

- Replace plug and refill with new transmission fluid (11.6 qt / 11 L). *See section 2.1.5 for specifications*
- Change engine oil.
  - Loosen filler cap, remove the sump plug and drain engine oil from the sump when it is hot.
  - Replace the oil filter.
  - Replace oil plug and refill engine sump with new oil (6 qt / 5.7 L). *See section 2.1.5 for specifications.*
- Inspect all fasteners on the outside of the dozer and tighten if necessary.
- Check track tension. Adjust if droop exceeds one inch. *See section 4.4.3 for detailed adjustment instructions*
  - It is normal for the track to stretch during the break-in period and must be adjusted to prevent slippage or coming off the drive sprocket
- Inspect free travel on the track brake (brake/steering) pedals. Adjust if necessary.
- Lubricate the dozer. (See **Lubrication** under the **Service** section in this Owner's Manual.)

See also **Every 10 Hours of Operation** under **General Maintenance** in the **Service Intervals** sub-section in the **Service** section in this Owner's Manual.

## **2.1.4 Daily Operating Checklist**

**Before operating the dozer each day (shift), perform the following safety and maintenance checks:**

- Test the dozer's safety systems.
- Check track tension. During normal usage, the track will stretch. During routine maintenance, the tracks should be inspected and re-adjusted as needed. *See section 4.4.3 for detailed adjustment instructions*
  - Track should have no more than 2/3 - 1 inch (1.5-2.5cm) of deflection as measured at a point halfway between carrier roller and drive sprocket. Adjust if greater than one inch.
  - Ensure drive sprocket and track crossbar mounting bolts are secure.
- Check fuel level and verify that the inlet valve for the fuel filter bowl is open.
- Check engine oil level. Add oil as-needed.
- Check transmission oil level. Add transmission oil as-needed.
- Check coolant level. Top-off coolant as-needed.
- Remove debris around engine, radiator, tracks, and other moving parts.
- Clean air intake screen.
- Check below the dozer for leaks. Tighten or replace leaking components as appropriate.
- Check and tighten any loose fasteners on the drawbar, transmission, linkages and other connection points.

## **2.1.5 Fuel, Lubricants and Coolant/Anti-Freeze**

Listed below are fuel, coolant, and lubricant specifications for the 35XTD crawler/bulldozer. For further information on lubrication, see *Lubrication* under the *Service* section later in this Owner's Manual.

### **Fuel**

**Always maintain 35XTD crawler/bulldozer fuel within the specifications:**

#### **Type of Fuel**

- Use No. 1 or No. 2 diesel fuel when ambient temperatures are above 50°F (10°C) (summer).
- Use only No. 1 diesel fuel when ambient temperatures are below 50°F (10°C) (winter).
- Ground the fuel funnel or nozzle against the filler neck to prevent sparks. Be sure to replace the fuel tank cap.
- To prevent engine malfunction and prolong the engine's service life, always use clean diesel fuel.
- Use of a good quality fuel conditioner specifically designed for use with diesel fuels is recommended.

# Operating Instructions

## Precautions When Adding Fuel



### Caution:

- Turn off the engine before adding fuel.
- Avoid flame or spark and do not smoke while adding fuel.
- Allow fuel to settle in the storage tank at least 48 hours before you fill the dozer fuel tank.
- Never use fuel from the bottom of a storage tank to fill the dozer's fuel tank.
- Filter the fuel before it goes into the fuel tank.
- Keep the refueling device(s) clean.
- Clean the fuel tank and sediment bowl and change the fuel filter regularly.
- Do not use fuel containing water.
- Do not use ether or other starter fluids to assist in starting the dozer.

## Types of Lubricants

Always follow the proper lubricant specifications when servicing and maintaining the 35XTD crawler/bulldozer.

- Change oil, transmission fluid, and hydraulic oil after 10-hour break-in, then after every 50 hours.

### Engine sump (crankcase)

API Service: CJ-4 Diesel Rated Oil.

- Ambient temp. below 32° F (0° C): 10W
- Ambient temp. 32° F (0° C) to 77° F (25° C): 10W-30
- Ambient temp. above 77° F (25° C): 15W-40 – **OR-**
- Year round (factory fill) : 15W40 diesel-rated oil

### Drivetrain (Transmission, rear differential, final drives)

API Service: CF/SL.

- Year-round: 30W non-detergent oil – **OR-**  
Trans-Hydraulic

### Hydraulic Sump (3-point hitch, blade control)

API Service: CF/SL.

- Year-round: 30W non-detergent oil – **OR-**  
Trans-Hydraulic

**Grease fittings** (blade pivot points, hydraulic cylinder ends, track rollers, idlers and carrier roller, 3-point hitch, clutch linkage)

- Year-round: NLGI Certified GC-LB Grease  
Premium EP Lithium

## Coolant/Anti-Freeze

Fill the radiator with a 50% mixture of a high quality single phase, ethylene glycol (anti-freeze) and clean soft water, to prevent the accumulation of scale in the engine's cooling system.

- Scale will reduce the system's cooling efficiency.
- Select an appropriate anti-freeze; low silicate, all-purpose coolant designed for heavy-duty diesel use.

# Operating Instructions

## 2.1.6 Controls and Instruments

Before operating the dozer, become familiar with all of the controls and instruments on the dozer. Most of these are shown in the illustrations below and on the next several pages. These illustrations are followed by descriptions of some of the controls and instruments.



### Warning!

- Study the controls and instruments as shown below.
- Serious personal injury and equipment damage can occur if the operator is unfamiliar with the proper function of controls or instrumentation and /or disregards them.

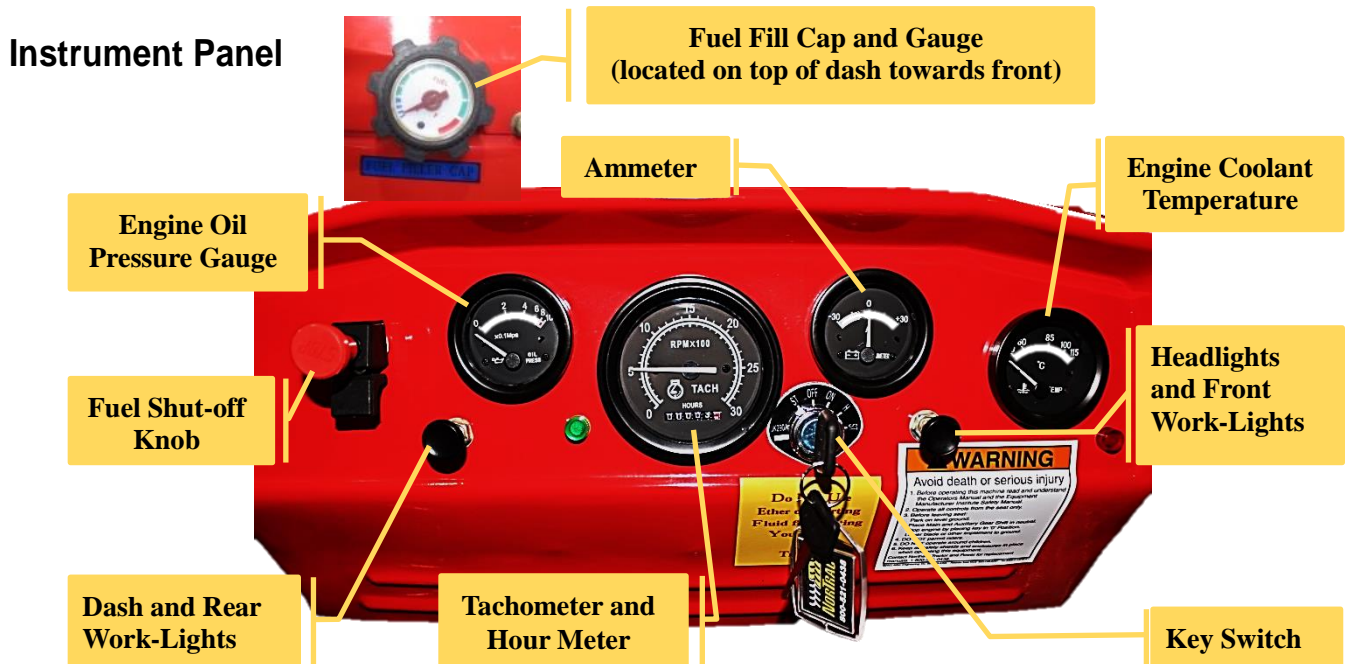

Listed below are basic descriptions and instructions for some of these controls and instruments:

**Ignition Key Switch** - The ignition switch (shown on the right), located in the lower middle portion of the dash panel performs the following functions:

- Controls power to all electrical circuits
- Apply power to the glow plugs for starting
- Initiate the starter.

These are the key positions:

**OFF position:** Normal position when dozer is not in use.

- All circuits are disconnected.

**Turning key clockwise to start a cold engine:**

**ON position:** Normal run position.

- All circuits except starter and glow plugs are connected.
- After starting, key is to be kept in this position.



# Operating Instructions

**H position:** Applies power to the glow plugs.

- Hold the key in this position for 15 – 30 seconds to preheat the cylinders for easier starting in cold conditions.

**ST position:** Engages starter, typically after preheating a cold engine.

- Do not engage the starter for more than 5-10 seconds or damage may occur due to overheating.
  - If the engine does not start within this time, wait at least 2 minutes, to prevent starter damage, before attempting to start again.

**Turning key counter-clockwise:**

**ST position:** No function.

## NOTE:

- Do not leave the key switch in the ON position after shutting down the engine.
- Power used by some gauges and electrical components when the key is in the ON position can drain the battery.

**Fuel Shut-Off Knob** - This control is located on the left side of the dash panel.

- To stop engine: pull out on the red knob to shut off the fuel supply.
- To start the dozer engine, allow the spring return to retract the red knob by pulling on the release lever located immediately below the red knob.

**Two-Position Front Head Light / Front Work Light Switch** – Located on lower portion of dash panel towards right side.

- Pull out to first position to turn on the two front headlamps.
- Pull out fully to also turn on the front work lights located at the top of the ROPS/FOPS.
- Push in to the respective positions to turn off front lights.

**Two Position Dash Light / Rear Work Light Switch** – Located on lower portion of dash panel towards left side.

- Pull out to first position to turn on the dash instrumentation lights.
- Pull out fully to also turn on the rear work lights located at the top of the ROPS/FOPS.
- Push in to the respective positions to turn off rear work and dash lights.

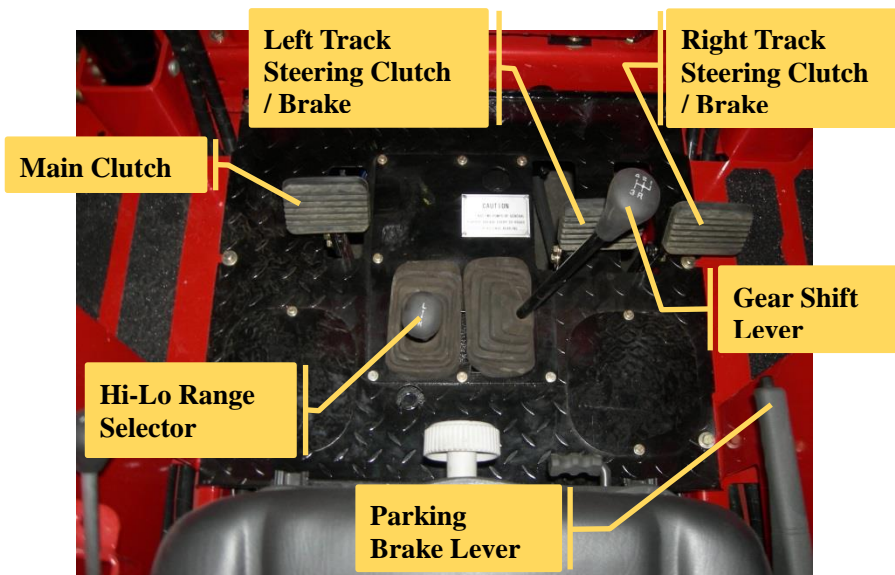

## Drivetrain Controls

**Track Steering Pedals (also known as Steering Clutch / brake pedals)** - These left and right pedals also referred to as "steering pedals".

Steering is accomplished by braking one track or the other. These pedals also allow independent control each track by engaging or disengaging the steering clutch for each track. Steering is accomplished by using these three positions for each pedal:

1. Track(s) locked to engine/transmission (responsive to engine and gear selection - pedal fully released).

# Operating Instructions

2. Track(s) free to coast (clutching - pedal partially depressed)

3. Track(s) Stopped or stopping (braking - pedal fully depressed)

**Gear Shift Lever** – Selects gear 1-4 or Reverse to match dozer speed and torque to working conditions.

**Hi-Lo Range Selector** – Used in conjunction with gear shift lever to multiply available gear ratios to match dozer speed and torque to working conditions.

**Main Clutch** – Used to connect / disconnect the engine power from the drivetrain and PTO.

## Operator Station

**Throttle** – With the engine running, pull upward / rearward on the handle to increase engine speed (rpm), push downward / forward to decrease engine speed (rpm).

**PTO Control Handle** - The clutch pedal must be depressed before attempting to move the PTO control lever to engage or disengage the PTO.

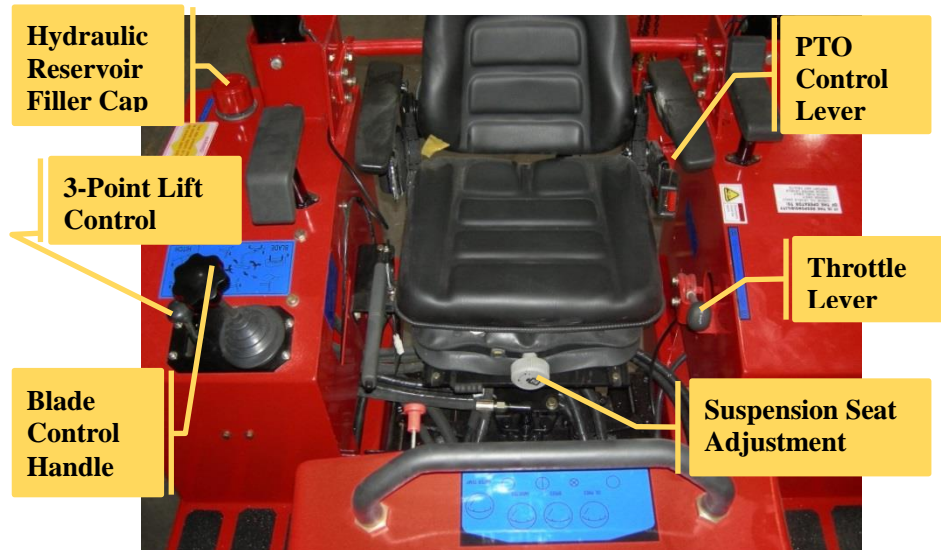

- When the PTO lever is in the middle (neutral) position, the output shaft is disengaged.
- Push the handle towards the front of the dozer for low speed (540 rpm).
- Move the handle towards the rear of the dozer for high speed (720 rpm).

**Always ensure the speed rating of any PTO driven implement matches the speed selected.**

### 2.1.7 Safety Precautions While Driving and Operating

Be familiar with the *Safety* section in this Owner's Manual and strictly observe these safety precautions when driving and operating the dozer:

#### **Warning!**

- Only engage the PTO when it is needed to power an implement.
- The PTO is the most dangerous device on the dozer.
- Always use the supplied PTO cover when the PTO is not in use!

- Be attentive to the working condition of the engine and main components, and listen for any abnormal sounds.
  - Pay special attention to the clutch and brakes.
  - Tighten any loose nuts and bolts on the exterior of the dozer.
  - It is good practice to always do a "walk-around" and perform a visual inspection. Problems can often be discovered and repaired before serious damage occurs.

# Operating Instructions

---

- Before starting the dozer, make sure that there are no persons or obstacles near the dozer.
- **NEVER** mount or dismount the dozer, or attempt to check or repair under the dozer, when engine is running
  - **If it is absolutely necessary, for repair purposes; place the hi-lo, gear shift and PTO levers in the neutral and block the tracks for safety.**
- Before driving the dozer up or down a slope, select the proper speed (and **NEVER** allow the engine to coast). **NEVER** turn sharply or shift gears while driving down a slope.
- If the engine —runs away", immediately pull out the choker pull rod. **DO NOT** disengage the clutch.
- Make sure the headlights and rear lights operate properly before using the dozer at night.
- Whenever the dozer is being transported on a trailer, place the gear shift lever in 1st gear. Use the tracks as the tie-down points.

Always check that the readings on all gauges remain normal.

**NEVER** rest your foot on the clutch pedal except when you are shifting gears. The clutch will wear prematurely or overheat and be damaged if kept semi-engaged.

## 2.2 Operating the Dozer

**This sub-section describes how to operate the 35XTD crawler/bulldozer. It covers these topics:**

- Preparing to start the engine
- Using the dozer
- Starting the engine
- Stopping the dozer
- Unique steering characteristics

For instructions on operating implements and attachments, see the *Operating Implements and Attachments* sub-section later in this *Operating Instructions* section.



### **Warning!**

- **The operator must recognize the operating characteristics of a dozer are significantly different compared to many other types of vehicles and heavy machinery.**
- **In addition to typical hazards associated with construction equipment, a crawler/dozer's steering system operation is unique; care should be taken to become familiar with them before working the machine.**

### **2.2.1 Preparing to Start the Engine**

**Before starting the engine:**

- Check the levels of the fuel, engine oil, hydraulic oil and coolant.
- Check that each accessory and the electrical system are working correctly. Open the fuel shut-off valve.
- Purge any air out of the fuel lines, using the bleed screw next to the fuel pump.

**Prime the fuel system as follows:**

- Pump the fuel pump primer slowly four times.

### **2.2.2 Starting the Engine**

**To start the engine, follow the instructions below.**

# Operating Instructions

## NOTE:

- To help start the engine in the winter or in weather below 30° F (1.1° C), use the NorTrac installed radiator hose heater to warm the engine before starting.
  - Be sure to plug in the heater 30-60 minutes prior to attempting to start.
  - For complete cold-weather starting instructions, refer to the “Quick Start Guide” or reference item #6 below.
- 
- Make sure the fuel shut-off knob is fully released (all the way forward).
  - Move the throttle approximately one-third of its travel range away from the idle position.
  - Place the gearshift and PTO control levers in their neutral positions.
  - Insert the key into the ignition key switch.
  - **Fully depress and hold the clutch down during the remaining steps.**



## Warning!

**Never use ether or other starting fluids to assist in starting the diesel engine!**

**Ether is highly flammable and can also cause permanent engine damage which is not covered by warranty.**

- To start the diesel engine under cold conditions;
  - Turn the key switch to the “H” position to preheat the engine cylinders using the glow-plugs for 20 to 30 seconds. In weather above 45° F (7.2° C) the glow plug pre-heat time can be reduced.
  - Turn the ignition switch clockwise to the starting position (“ST”, all the way to the right), to engage the starter motor. Do Not operate the starter for more than five to ten seconds at a time.
  - If the engine doesn’t start within that time, wait at least two minutes before you try again, to protect the starter and battery.
  - If the engine does not start after several attempts, search for the cause (fuel shut-off knob, fuel supply, etc.) before attempting to start again.
- When the engine starts, release the key switch and it will return to the “ON” position, providing power to all circuits.
- After the engine starts, allow to run at idle speed (600 RPM) until the engine temperature begins to rise and oil pressure is steady between 0.2-0.5 MPa.
- After starting the engine, check all instruments on the dashboard to ensure they are all in working order.
- Monitor gauges during warm-up. Verify that all gauges gradually approach their normal readings.
- After warm-up the oil pressure gauge should read 0.2-0.5 MPa
- Engine coolant temperature gauge should stabilize between 70-90 degrees Celsius.
- The ammeter should be in the middle or slightly in the “+” (charging) range.
- After engine is running, confirm that the gearbox and PTO are in the neutral position and release the clutch pedal.
- After warm-up, adjust the throttle as needed for the task to be performed.

## **2.2.3 Unique Steering Characteristics of a Dozer**

**When using the crawler/bulldozer, you must be aware of its unique steering characteristics:**

- The dozer does not have a steering wheel; it is steered by use of the track steering pedals (also referred to as steering clutch/brake pedals or steering pedals).
  - See the *Operator Station* diagram earlier in this manual for a view of these pedals.

**When backing up, the steering (track pedal) procedure is the reverse of the procedure for driving forward. The two procedures are noted below:**

# Operating Instructions

---

- **Driving Forward**

- When driving forward; depress the **right** steering pedal to turn the dozer to the right. Similarly, depress the **left** steering pedal to turn the dozer to the left

**When driving forward, pressing on a steering pedal removes power and applies braking to the track that will be on the inside of the turn. The track that will be on the outside of the turn continues to be powered and run freely; the outside track will then rotate around the inside track.**

- **Backing Up**

- When backing up, the steering procedure is reversed.
- To turn right- step on the **left** pedal; to turn left - step on the **right** pedal.

Because of these unique handling characteristics, all operators should be trained by a qualified individual or should read this manual to become knowledgeable and skilled in operating this machine.

## **2.2.4 Driving the Dozer**

**After the engine is started, allow it to warm up to 70-90<sup>0</sup>C before beginning to work:**

- Using the 3-Point Lift control lever, raise any attached implement.
- Press the clutch pedal, and put the gear shift lever into the desired gear.
- Place the Hi-Lo range selector in the desired range. Note, the lever can be placed in Neutral (disengaged) by centering between the L-H markings.
- Observe the surroundings to ensure there are no hazards in intended path.
- Increase the engine speed gradually and simultaneously release the clutch pedal to start the dozer smoothly.

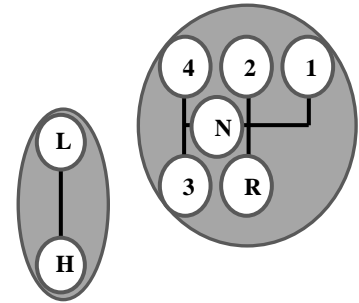

**When changing gears, high-low range or engaging the PTO, the clutch pedal must be completely depressed and the dozer brought to a complete stop to avoid damage to the gears.**

If the desired gear cannot be easily engaged, partially release the clutch pedal and depress it again (double-clutch) to engage the desired gear.

**Riding the clutch (holding the pedal in a partially depressed position) will significantly reduce its service life.**

**The highest productivity and maximum economy can be obtained by selecting the proper gears.**

If the engine begins to lug down and emits dark exhaust, shift the gearbox to a lower gear or shift the Hi-Lo range selector to “L” to avoid overload.

**When using the dozer, follow these guidelines:**

- Make sharp turns only at low speed.
- Do not use first and second gears (L-1st and H-1st) for plowing and harrowing to avoid overloading and damaging the transmission.
- Be observant of other signs that the dozer may be overloaded. If the engine sounds louder and more labored and produces dark smoke, it may also be overloaded; shift the gearbox or Hi-Lo selector to a lower gear.
- Monitor the dozer’s gauges. Oil pressure should be between 0.2-0.5 MPa. Water temperature should be between 70° C - 90° C. The ammeter should be in the middle position or charging (+).

# Operating Instructions

---

- Listen attentively to the engine and transmission. If abnormal sounds are heard, stop the engine at once and address the problem.
- Do not ride the clutch or use the clutch to control the speed of the dozer.
- Do not drive the steel-tracked dozer at high speed across a hard surface.

## Using the Clutch

Follow these guidelines when operating the clutch:

- Always depress and release the clutch fully.
- When engaging the clutch, do so slowly and smoothly without “popping” the clutch.
- When driving the dozer, do not keep the clutch pedal partially depressed. This will overheat and wear out the clutch and release bearing prematurely.
- Do not use the clutch to control speed.

## Putting the Dozer in Gear

Make sure there are no obstacles or persons around the dozer.

With the engine at low speed, depress the Main Clutch pedal and put the Gear Shift and Hi-Lo Range selectors in the required position for the work to be performed.

Slowly release the clutch pedal while simultaneously increasing the hand throttle so the dozer begins to move smoothly. After the dozer has started moving, remove your foot from the clutch pedal completely. Do not ride the clutch and never rest your foot on the clutch pedal except when changing gears.

## Using the Steering Pedals

Follow these guidelines when using the Steering Pedals:

- If you are not slowing the dozer, don't “ride” the brakes by keeping the brake pedal partially depressed. This will overheat and wear out the brake bands prematurely.
- Avoid contaminating the brake bands with oil.
- When driving straight forward and the dozer is pulling to the right or left, adjust the tracking lever (located by your right heel).

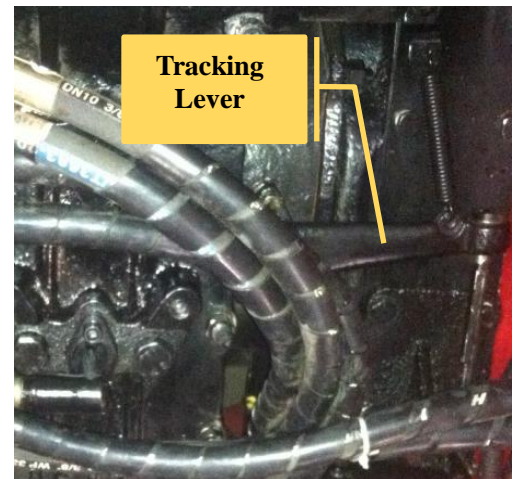

## Stopping the Dozer

When stopping the 35XTD crawler/bulldozer:

- Use the throttle to reduce the speed of the dozer.
- Depress the clutch pedal and then step on the steering / brake pedals.
- When the dozer stops, bring throttle to the idle position, shift gearbox and Hi-Lo Range selector into neutral and engage the parking brake.
- Disengage the PTO drive.
- Release the clutch and steering / brake pedals and let the engine run at idle speed.
- Lower blade and any implements to the ground.
- Allow the engine to continue running until the engine coolant temperature drops to 76 degrees Celsius (170 degrees Fahrenheit) or lower.
  - **Do not shut the engine down while it is at a high temperature.**

# Operating Instructions

## **Caution!**

When the engine temperature is elevated above normal operating range, park the dozer and allow the engine to continue running at idle speed until engine temperature has cooled down into normal operating range before shutting down at end of working session.

- After the engine has cooled down, Pull out the fuel shut-off knob to stop the engine.
- When the engine has stopped, pull on the release lever to allow the fuel shut-off knob to retract.
- Turn the key switch to the “OFF” position and remove key. If the dozer will be not be used for an extended period, close the fuel tank petcock.
- To eliminate pressure in the Hydraulic Hitch System, cycle the 3-Point hitch control back and forth.
- Dismount the dozer.
- If the dozer is on a slope or incline, block the tracks.

## **Warning!**

Always use the proper anti-freeze mixture in the cooling system.  
Never use an anti-freeze/water mixture that is less than 50% anti-freeze.  
Check anti-freeze to ensure it is safe to -35°F to prevent freezing damage to engine.

## 2.3 Working Systems, Implements and Attachments

This sub-section provides basic instructions for use of the 35XTD dozer’s working systems and connecting and operating implements. The following topics are covered:

- Operating the six-way blade
- 3-Point hitch system operation
- Operating the power take-off (PTO)

When using the 3-Point hitch and PTO with implements or attachments, be sure to read the owner’s manuals for each implement or attachment.

The hydraulic system on the 35XTD dozer provides power to both the six-way blade and the 3-Point hitch lift.

Controls for both systems are located on the console to the operator’s right side:



### 2.3.1 Six-Way Blade

The six-way blade is controlled by a 3-axis joystick.

#### **Operating the Six-Way Blade**

- The dozer’s blade can be moved in 3 axes:
  - Raise and Lower are accomplished by moving the joystick forward or backward
  - Tilt Clockwise and Tilt Counter-clockwise by moving the joystick lever to the right or left.
  - Angle Left and Angle Right by twisting the joystick handle counter-clockwise or clockwise, respectively.

An operating label on the dozer next to the controls illustrates each of these functions.

# Operating Instructions



## Warning!

Always lower the dozer blade and any implements to the ground and release stored hydraulic pressure by cycling the control levers several times in all directions after engine is shut down.

### 2.3.2 3-Point Hitch System

The 3-point hitch lift control is lever operated.

#### Operating the Hydraulic Hitch System with Implements

The hydraulic 3-Point hitch system allows you to attach, lift, and lower a variety of implements, as well as to adjust and maintain their working positions.

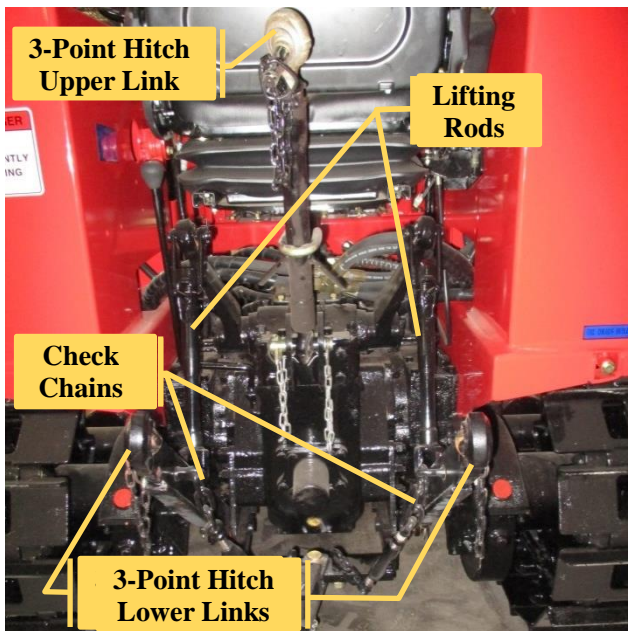

To raise the hitch, move the 3-Point Hitch control handle backwards. Push the handle forward to lower the hitch.

The 3-point lift control is proportional; the further the lever is moved in either direction, the faster the implement will raise or lower.

With the lever at the neutral position, the hitch floats between its last position and the highest position.

**Note:** The 3-Point hitch is raised hydraulically, and lowers via gravity acting on the weight of the attached implement.

With no implement attached, it may be necessary to push down on the arms to lower them.

When lowering an implement, slow the rate of descent as the implement approaches the ground by moving the control handle back towards the center (neutral) position. This will help avoid damage to the implement from impact with the ground.

When using a ground engaging implement, always raise the equipment before turning the dozer and lower it back into working position only after the dozer has completed the turn and is running in a straight line.

#### Positioning and Draft/Lift Control

By moving the 3-Point Hitch lift positioning control handle forward or backward, the height of an implement can be adjusted for proper working level.

Once the desired position is obtained, release the handle and it will return to the **Neutral** position and the 3-point arms will remain in the set position.

Positioning and draft/lift control assists you in field plowing and requires the use of a supporting wheel. It allows you to maintain a uniform plowing depth even when the soil's resistance to the plow varies widely.

#### Mounting an Implement

Before mounting an implement, start the engine to provide power to the tractor's hydraulic system.

Move the Lift/Position Control Handle (shown on the previous page) to the "lower" position to slowly lower the lifting arms while backing the dozer towards the implement. When the arms are lined up with the implement mounting pins, lower the front blade, stop the engine and dismount the dozer to complete the attachment process.

# Operating Instructions



## Warning!

Before dismounting the dozer, always place the gearshift lever in 1<sup>st</sup> gear, stop the engine and remove the keys to avoid accidental start up and to keep the dozer from moving while unattended.



## Danger!



- PTO wrapping or entanglement will result in severe injury or death.
- Do not approach a PTO driveline unless it is disengaged and has stopped rotating.
- Stay clear of all rotating components.

First, connect the implement with the left lower link, then with the right lower link. If the pin of the implement does not line-up correctly with the lower right link, the length of the right lower link can be adjusted by turning its adjusting handle. Finally, connect the upper links and lock all of the links with lock pins.

## Selecting Upper Link Attaching Point

When using Lift/Positioning Control to control tillage depth, connect the front end of the upper link through the middle pin hole on the rear of the dozer. Using this position will allow you to make adjustments depending on the depth of tillage required.

To protect the hydraulic lifter from damage, never use the attaching pins of the upper link for pulling.

## Adjusting the Longitudinal Level

To keep the implement horizontal in the longitudinal plane (i.e., to keep the implement level from front to rear), adjust the length of the upper link of the hitch. If the front is lower than the rear, extend the upper link. Conversely, if the front is higher than the rear, shorten the upper link.

## Adjusting the Lateral Level

To keep the implement horizontal in the lateral plane (i.e., to keep the implement level from side to side), adjust the length of the **right** lifting rod. Extending the right lifting rod lowers the right side of the implement; shortening it raises the right side. Typically, **left** lifting rod does not need adjustment, unless the right rod has been adjusted to its limits.

## Check Chains

The check chains help the dozer and implement to maneuver in the field, while preventing the implement from swinging against the sprocket/track when the dozer turns or the implement is lifted. When the implement is in the plowing position, the check chains should be loose enough to permit limited side-to-side movement of the implement relative to the dozer. **NEVER** try to adjust the tension of the check chains while the dozer is moving.



## Caution!

After any adjustments are made and before each use, check to ensure all jamb nuts are tight and all pins and keepers are installed and locked in place.

# Operating Instructions

## 2.3.3 Power Take-Off (PTO)

The power takeoff (PTO) is designed to provide mechanical power to implements attached to the 3-point hitch. Power is transmitted from the PTO shaft, extending from the rear of the dozer's differential housing, through a rotating driveshaft connected to the implement.

The PTO is engaged and disengaged by fully depressing the clutch pedal and moving the PTO control lever located on the left side of the transmission.



### Danger!

PTO wrapping or entanglement will result in severe injury or death.

Do not approach a PTO driveline unless it is disengaged and has stopped rotating.

Stay clear of all rotating components.



### NOTE:

- The PTO has two speeds: 540 and 720 RPM.
- Most implements in the U.S. use the 540 RPM setting.
- Always consult the owner's manual for the implement to ensure the proper speed is selected.
- **NorTrac recommends using a slip-clutch driveline with ground engaging implements and those with a large rotating mass (flywheel) such as a rough-cut mower, generator or chipper to prevent damage to the transmission which is not covered under warranty.**

- The **PTO Control Lever** should be in the **Neutral** (PTO Disengaged) position when the PTO shaft is not in use (as shown).
- The PTO drive can be shifted from the **Neutral** position into either:
  - High speed range (720 rpm) by moving the PTO control lever forward - or -
  - Low speed range (540 rpm) by moving the control lever backward.

**Always fully depress the clutch when engaging or disengaging the PTO or changing PTO speed range.**

### To operate the PTO:

**When choosing equipment for the (PTO), ensure that the power and speed ratings are compatible with the rating of the PTO shaft (31.5 HP at 540 RPM).**

- With engine stopped and the PTO disengaged, remove the PTO safety cover.
- Attach implement to dozer's 3-point hitch.
- Connect the PTO shaft to the implement and dozer, ensuring both ends of the driveshaft are securely locked onto the respective shafts.
- Confirm that the **gearshift**, **Hi-Lo** and **PTO** control levers are all in the **Neutral** position.

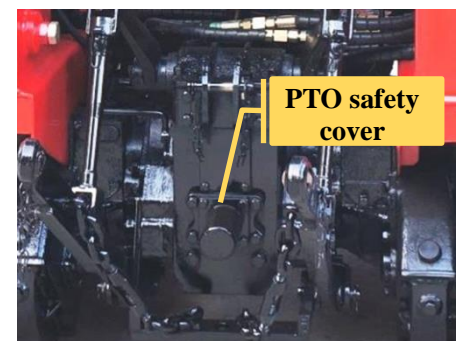
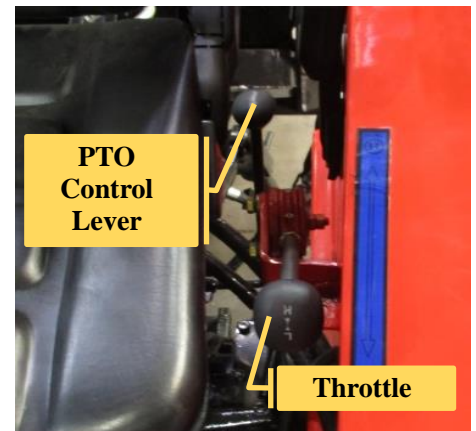

# Operating Instructions

---

- Start the dozer engine.
- Fully depress the clutch pedal, and then shift the PTO lever to engage the PTO at the appropriate speed for the installed implement.
- Release the clutch pedal slowly and the shaft will begin to rotate. Set the engine rpm slightly above idle speed initially to ensure that it is operating properly.
- Adjust the throttle to the rated speed when ready to work.



## Caution!

- Disengage PTO by depressing the clutch and moving PTO control lever to the **Neutral** position to remove power from the implement when traveling to / from the worksite to avoid damage or personal injury from moving parts on the implement.

## 3. Electrical System

The electrical system for the 35XTD crawler/bulldozer is a 12-volt, direct current, negative ground system. It is used to start the engine, power the dash instruments and lights, headlights and work-lights for night operation.

### 3.1 General

The electrical system consists of a **battery** for starting the engine and powering accessories when the engine is stopped, an **alternator** to power the system and recharge the battery and a **voltage regulator** to prevent over-voltage.

An Ignition Key Switch controls which electrical circuits receive power. This multi-position switch is described earlier in this section under *Controls and Instruments*.

Accessory switches control the headlights, work-lights, dash lights and some instrumentation.

All controls and instruments are dash mounted and within easy reach of the operator.

When the Ignition Switch is in the “H” (glow plug) or “ST” (start) positions, the accessory circuits are not powered. The Key Switch is spring-loaded and will return to the Run (ON) position when released. In this position, the accessory circuits are powered.

In order to maintain the electrical system it is recommended that a Volt-Ohm meter (either analog or digital) and an inline circuit tester (12 Volt) be available.

All circuits are connected through the fuse box.

### Wiring Diagram

Use the following **Wiring Diagram** as a guide for any trouble-shooting or repairs. For further assistance, see *Electrical System* under the *Troubleshooting* section in this Owner’s Manual.

# Operating Instructions

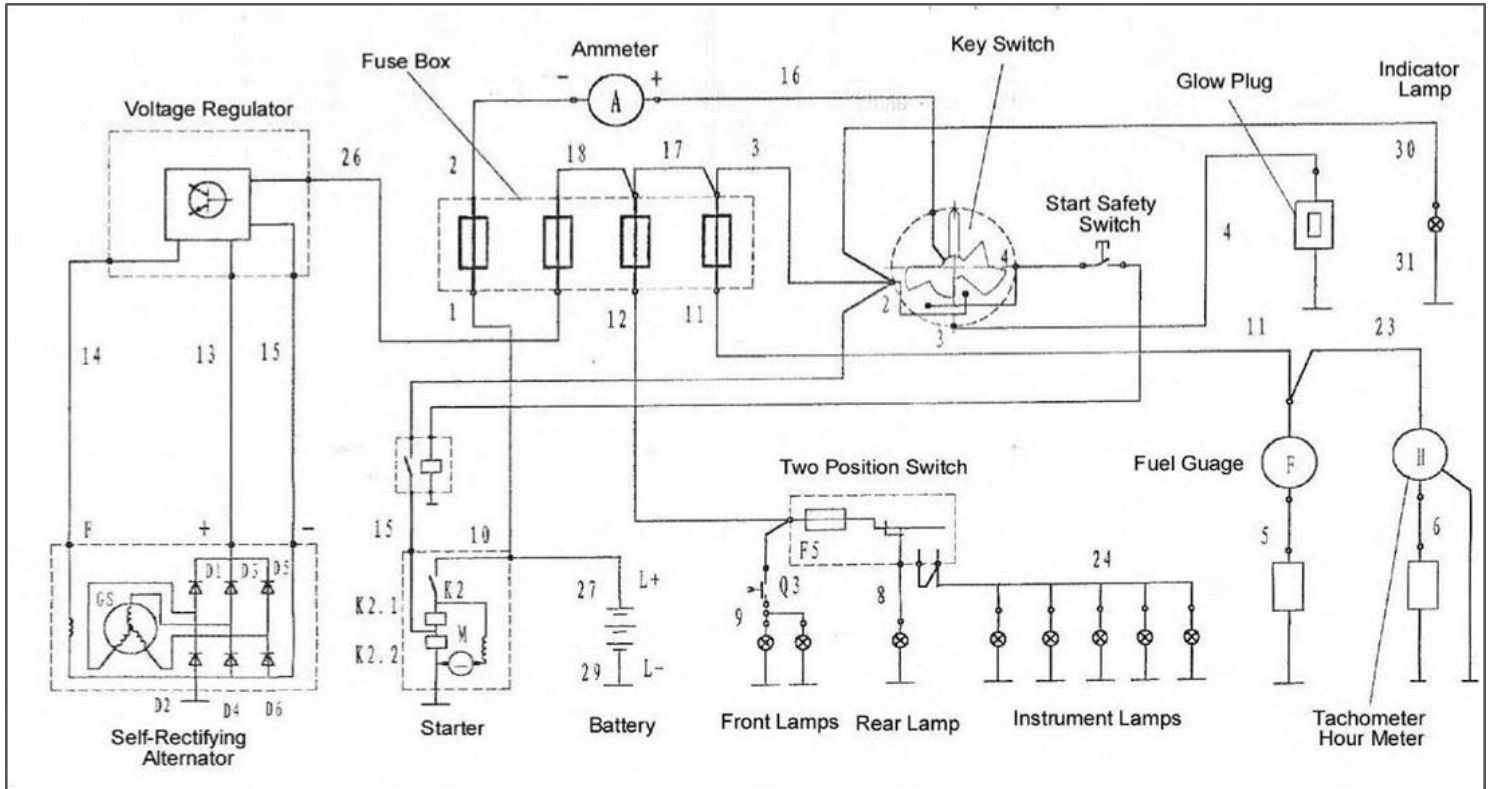

### 3.1.1 Battery

The battery stores electrical energy produced by the alternator for the purpose of providing power to the starter and glow plugs for engine starting. It can also power the accessory circuits if the engine is at low idle and the alternator output is insufficient to meet the accessory power needs.

Maintain the battery as described in the **Battery** section, of **Electrical Servicing** in the **Service** section of this Owner's Manual.

Recharge the battery at regular intervals if stored for extended periods. A healthy battery will maintain a voltage of 12.66V.

### 3.1.2 Fuse Box

The fuses are located under a rectangular plastic cover that is mounted to the left side of the engine bay (facing the engine from the front).

There are four working and two spare fuses. They are color-coded for clarity as well as marked by amperage value, as shown on the right.

### 3.1.3 Alternator and Voltage Regulator

The alternator is a negative ground design.

To avoid damaging the alternator, voltage regulator or battery, ensure all positive and negative connections are correct! Always use the voltage regulator in conjunction with the alternator.

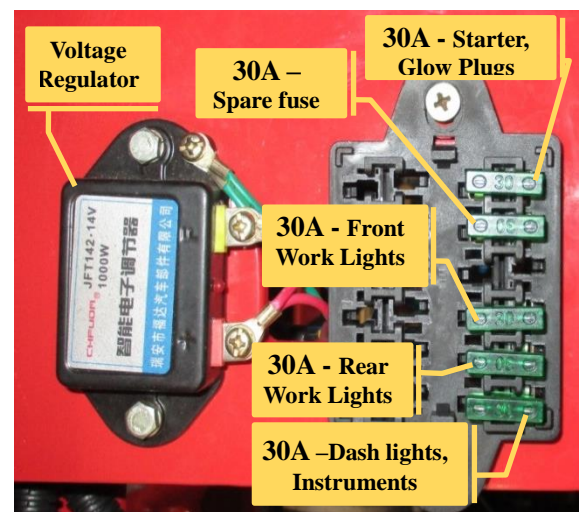

# Operating Instructions

---



## Caution!

- **Do Not** check alternator operation by short-circuiting across its terminals.
- **Do Not** use a Volt-Ohm meter setting above 100 volts when checking the alternator condition; use only a high-resistance tester to avoid damaging the alternator's diodes.

### **3.1.4 Starter**

- Keep the starter clean and the wire contacts in good condition. To insure contamination-free cable contacts, use a high-grade battery terminal lubricant; this will prevent the contacts from oxidation buildup.
- **Do Not** operate the starter for more than 10 seconds at a time.
- If the engine does not start within this time, wait at least 2 minutes, to prevent starter damage, before attempting to start again.
- If the engine does not start after 2-3 attempts, review fuel and starting systems for possible causes before additional starting attempt.
- **To start the engine in the winter, preheat the engine using the glow plugs before engaging the starter.** (See the cold start instructions under *Starting the Dozer* in the *Operating the Dozer* topic in the *Operating Instructions* section of this Owner's Manual.)

# Service

---

## 4. Service

This section provides service instructions for the following topics:

- Service intervals
- Lubrication
- Engine servicing
- Driveline servicing
- Storage and startup after storage
- Miscellaneous servicing

### 4.1 Service Intervals

This section describes the routine maintenance procedures that should be performed regularly to keep the dozer in proper operating condition. These procedures include:

- General maintenance
- Fuel system maintenance



#### Caution!

Before each use of the dozer, perform a “walk-around” visual inspection of the dozer looking for any fluid leaks or loose fasteners. Correct any issues before operating.

#### 4.1.1 General Maintenance

Perform the general maintenance procedures listed on the following pages at these intervals:

- Every 10 hours of operation
- Every 50 hours of operation
- Every 100 hours of operation
- Every 500 hours of operation
- Every 1000 hours of operation



#### Caution!

Before performing any general maintenance, carefully review the *Maintenance Precautions* sub-section and other applicable portions of the *Safety* section of this Owner’s Manual.

For maintenance before and after long-term storage, see the *Storage and Startup after Storage* sub-section later in this *Service* section of the Owner’s Manual.

# Service

---

## Every 10 Hours of Operation

Perform the following preventive maintenance tasks after every 10 hours of operation. (After the **first** 10 hours of use; see also *Service after the First 10 Hours* in the *Initial Owner Break-in* sub-section in the *Operating Instructions* section of this Owner's Manual.)

- Clean all dirt and debris from the dozer and implements.
- Keep the engine clean.
  - Take care to keep the electrical equipment clean and dry.
- Clean all dust and debris out of the radiator fins to ensure proper cooling.
- If operating under extremely dirty conditions, clean the air filter and battery.
- Check all exterior nuts and bolts, especially on the tracks and engine mount. Tighten as necessary.
- Check the connection between the engine and the transmission.
- Check all critical fluids; hydraulic oil, engine oil, engine coolant and transmission. Refill as necessary.

**NOTE:**

**Wait a minimum of 15 minutes after engine has stopped before checking the hydraulic oil level.**

- Check oil level in the engine sump; it should be between the two marks on the dipstick, near the upper mark.
  - For new engines or engines that have been stored for a prolonged period, fill oil to the upper mark on the dipstick. Start engine and run at idle speed for 5-10 minutes. Stop engine and recheck oil level.
- Check the coolant level in the radiator and check engine temperature after starting the engine.
- Check for any leaks of oil, coolant, or fuel on the engine fittings or on the ground.
  - Investigate and repair as necessary.
- Check the track tension. If it droops more than one inch, adjust accordingly.
- Grease the locations indicated under *Lubrication* in the *Service* section later in this Owner's Manual.
  - Before greasing, use a clean rag to remove any dirt or water from the lubricating points.
- Make sure all engine fasteners and accessories are properly tightened and adjusted.
- **After the FIRST 10 working hours of normal running**, change the engine oil and filter.
  - Change the oil and filter again at 50 hours [40 hours after the initial change] and every 50 hours thereafter as described below.

## Every 50 Hours of Operation

After every 50 hours of operation, perform the following maintenance tasks (in addition to the tasks performed after every 10 hours of operation):

- Replace the engine oil in the engine sump and replace the oil filter.
- Clean/replace the air filter.
- Change the fuel filter.

# Service

---

- Check fan belt tension and adjust if necessary.
  - Tension is checked by pressing the middle of the longer side of the belt with a force of about 12 ft-lbs. Belt should deflect ~1/2 inch.
  - An alternate method is to twist the belt; it should be able to rotate a half turn.
- Check and adjust the free travel of the clutch pedal and brake pedals.
- Wipe the battery with a cloth. Coat the battery terminals with corrosion preventative.

## Every 100 Hours of Operation

After every 100 hours of operation, perform the following maintenance tasks (in addition to the tasks performed after every 10 and 50 hours of operation):

- Re-torque the cylinder head bolts.
- Check the valve lash and re-adjust according to the recommended procedure.
- If necessary, fill the grease nipple of the water pump bearing with premium industrial grade grease as specified under *Lubrication* in the *Service* section of this Owner's Manual.
- Clean out the dust in the intake manifold.
- Use compressed air to clean the inside of the air cleaner and blow dust and debris out of the filter element pleats.
- Clean accumulated carbon from the exhaust pipe, inside of the exhaust manifold and muffler.
- All parts dismantled for maintenance should be cleaned, and properly reassembled.
  - After reassembly, start the engine to confirm proper operation. Correct any problems.
- Adjust clutch as described in the *Clutch* sub-section of the *Transmission Servicing* section of this manual.
- **After every 200 accumulated operating hours**, also check the fuel injection pressure and the spray pattern of the fuel injectors. If necessary, replace any injectors which are not performing properly.

## Every 500 Hours of Operation

After every 500 hours of operation, perform the following maintenance tasks (in addition to the tasks performed after every 10, 50, and 100 hours of operation):

- Check the fuel injection timing and readjust if necessary.
- Drain the fuel from the fuel system by removing the drain plug on the right side of the fuel tank. Replace with clean fuel and diesel fuel conditioner.
- Clean the strainer for the engine oil pump intake.
- Flush the transmission case and replace the lubricating oil.
- Check the cleanliness of the hydraulic oil.
  - Drain and replace if needed
  - Replace hydraulic fluid filter, located in the right body compartment, near the tank (see photo at right).



# Service

---

- Check the seal on intake and exhaust valves by turning the crankshaft and listening for the sound of leakage.
  - If necessary, remedy by lapping the valve sealing lip or the valve seat.
  - For severely worn valves it may be necessary to grind and lap the valves and seats.
- Adjust the valve lash as specified under Engine Servicing in the Service section of this Owner's Manual.
  - Specifications are listed in *Clearance between Valve and Rocker Arm* under *Engine Specifications* in the *Specifications* section in this Owner's Manual.)
- Re-torque cylinder head bolts, connecting rod bolts, connector bolts, main bearing-cover bolts, and flywheel bolts.
- Clean the cooling system with a radiator flush kit available from a local auto parts store.
  - Follow kit instructions. Refill the cooling system with a clean antifreeze/water mixture.
  - Test for freeze protection to -35<sup>0</sup>F
- Make sure all wiring contacts for the electrical system are firmly connected. Remove any contamination.
- Check steering clutch / brake linkages for proper free play and sequencing.
- Check crankshaft seal and replace it if it is worn out.

## Every 1000 Hours of Operation

After every 1000 hours of operation, perform the following maintenance tasks (in addition to the tasks performed after every 10, 50, 100, and 500 hours of operation):

- Inspect the front bearing and the release bearing of the clutch and replace if necessary.
- Replace the muffler if necessary.
- Clean carbon from the exhaust manifold.

**After every 1500 accumulated operating hours**, also perform the following maintenance:

- Remove cylinder head; check valves, valve seats, and other parts of the cylinder head assembly. Check the cylinder head for signs of warping.
- Remove carbon deposits on the surfaces of the cylinder head, liner, piston, piston ring, etc. and clean them.
- Check and measure the pistons and piston rings for wear.
- Check and measure the cylinder liner for wear.
- Replace the head gasket and carefully torque the head bolts.
- Check the crankshaft main journals and crank pins for wear. Clean the crankshaft's lube oil passages.
- Check the main bearing and connecting rod bearing shells for wear.
- Clean the cylinder block's oil passages and replace lube oil.

After completing the above maintenance, run the dozer for a short time to check for normal operation.

# Service

---

## **4.1.2 Fuel System Maintenance**



### **Caution!**

Before performing any fuel system maintenance, carefully review the *Maintenance Precautions* sub-section and other applicable portions of the *Safety* section of this Owner's Manual.

**Follow these guidelines to keep the fuel system in best operating condition.**

Diesel fuel systems must be kept clean and free of water. The fuel injectors require very close tolerances to operate at the high pressures necessary to atomize fuel at high cylinder head compression and do not tolerate foreign matter or the presence of water.

The fuel system is fitted with the following filters:

- The pre fuel pump filter screen, located inside the securing bolt that holds the rubber connecting hose between the fuel tank and the engine fuel pump. It is located under the fuel pump assembly. The canister filter, a post pump filter, is located on top of the engine directly above the fuel pump assembly.

Filter life depends more on careful maintenance than it does on hours or conditions of operation. The necessity for careful refueling with clean fuel to minimize contamination of the diesel fuel system cannot be over-emphasized.

**Follow these recommended precautions:**

- If condensation is suspected, loosen the drain plug located under the fuel tank and bleed the tank until clear fuel is present. To minimize water in the fuel tank always store the dozer with a full tank of fuel; this minimizes condensation (moisture) from collecting in the tank.
- Use a good quality diesel fuel conditioner each time fuel is added to the tank.

## **4.2 Fluid and Lubricant Servicing**



### **Caution!**

Before lubricating the dozer, carefully review the *Maintenance Precautions* sub-section and other applicable portions of the *Safety* section of this Owner's Manual.

**This sub-section provides instructions for lubricating the 35XTD crawler/bulldozer. Photographs of the dozer's fill and drain orifices appear below, followed by fill and drain instructions.**

See also *Types of Lubricants* under *Fuel, Coolant, and Lubricants* in the *Operating Instructions* section of this Owner's Manual.

# Service

## 4.2.1 Fill and Drain Instructions

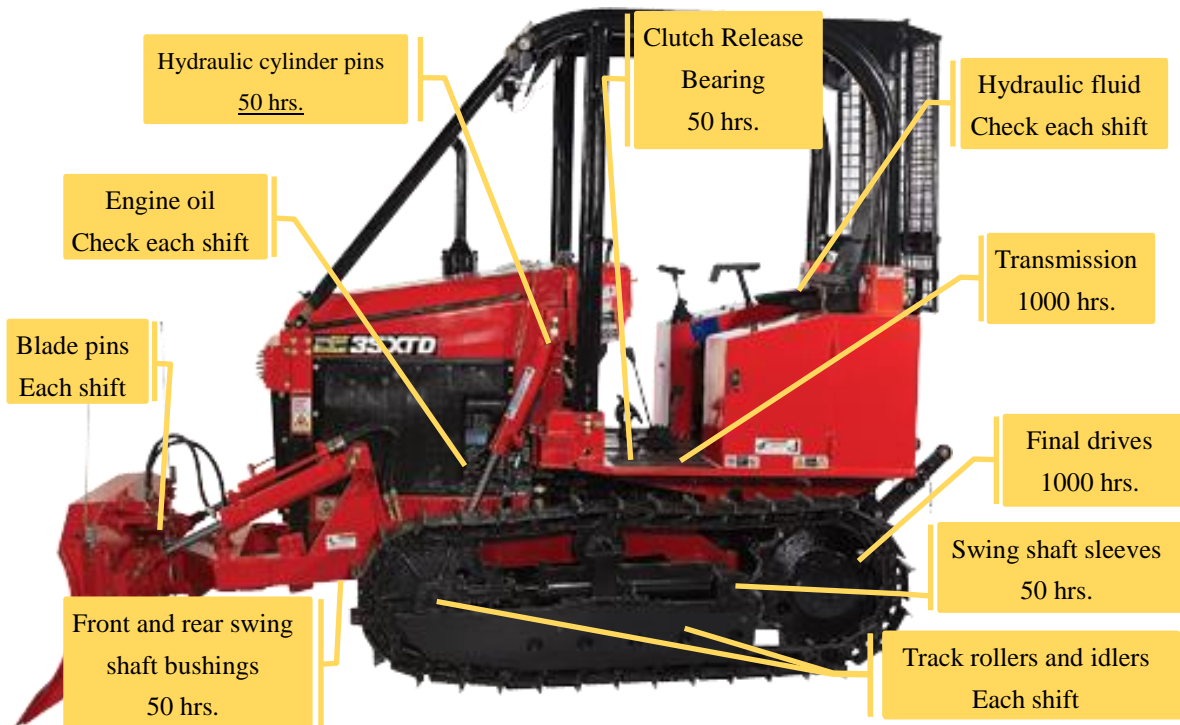

Follow these instructions for filling and draining oil and fluids from the dozer.

### Fill and Drain Locations

Shown above are fill and drain locations on the 35XTD crawler/bulldozer.

### Engine Oil System

Check engine oil level using the dipstick located on the left side of the engine, directly behind the fuel pump. To drain the engine oil, locate the engine oil drain plug directly below the dipstick on the bottom of the engine.

### Hydraulic Reservoir

The hydraulic reservoir is integrated into the right-side compartment and is equipped with a sight gauge to monitor the hydraulic oil tank fill level.

Stop engine and wait for a minimum of 10-15 minutes before hydraulic reservoir level can be read accurately.

Add hydraulic fluid as needed to bring to the proper level between the two marks.



### Grease Fittings

Grease all grease point fittings at all pivot points. Dozers are designed to accept grease for preventative maintenance.

Typically 2 pumps with a grease gun or until the grease begins to squeeze out of the joint.

# Service

## Grease these locations:

1. Brake pedal pivot/linkage
2. 3 point hitch, lift turnbuckles and swing balls
3. All pivot points on front blade and carriage
4. Track rollers / Track idlers
5. Swing shaft bushings
6. All hydraulic cylinder pins

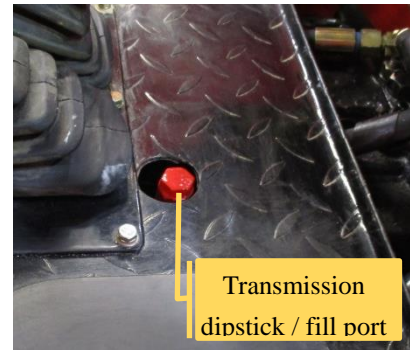

## Transmission Oil Sump

The transmission oil dipstick, located at the base of the gear shift lever, is integrated into the fill port plug (painted RED). To drain the transmission oil, remove the fill plug, then the drain plug located on the bottom rear of the dozer, directly below the seat (see photos on right).

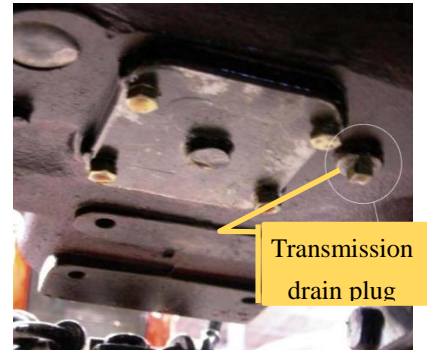

## Engine Cooling System

The cooling system does not incorporate an overflow tank.

With the engine cool, remove radiator cap and visually inspect the cooling system. If the coolant is cloudy, discolored (rusty or brownish) or is more than 2 years old, it should be drained, the system flushed and refilled. To flush the radiator, locate the petcock on the lower right side of the radiator; move the lever up to release fluids or down 90 degrees to close the valve.

The engine block is also fitted with a petcock and drain tube, located on the left side, to the rear of the fuel injection pump. Rotate the petcock clockwise to open (90 degrees is full open) or counterclockwise to close.

- Clean the cooling system with a radiator flush kit available from a local auto parts store.
  - Follow kit instructions. Refill the cooling system with a clean antifreeze/water mixture.
  - Test for freeze protection to  $-35^{\circ}\text{F}$ .

**Engine coolant is toxic and extremely deadly when consumed by people or animals.**

**Make sure to properly dispose of all excess and waste coolant.**

## 4.3 Engine Servicing



### Caution!

Before servicing the engine, carefully review the *Maintenance Precautions* sub-section and other applicable portions of the *Safety* section of this Owner's Manual.

**This sub-section provides engine servicing procedures intended for use by qualified service technicians.**

**The following topics are covered:**

- Valve clearance

# Service

- Fuel injection timing
- Fuel injector trouble-shooting and replacement
- Fuel injection pump
- Engine oil pressure

## **4.3.1 Valve Clearance**

During engine repair or routine engine maintenance, check and adjust valve clearance. The recommended method of adjusting the valve system and valve lash is described below:

- Remove the valve cover.
- Check and tighten the retaining nuts holding down the rocker assembly.
- Reassemble with valve contact cones pointing outwards.
- Rotate the engine to the Top Dead Center (T.D.C.) position.
  - The inspection window of the flywheel housing exactly points to the “O” mark on the flywheel rim, or the “O” mark on the crankshaft pulley is aligned with the pointer on the front cover of the timing gear housing.
- Insert a feeler gauge between the rocker arm and the tip of each valve stem starting with the front cylinder, as shown in the figure at the right.
  - **Check and adjust the intake valve clearance to .007 - .009 inches and exhaust valve clearance to .009 - .011 inches. These tolerances are to be performed with the engine cold.**
- After turning the crankshaft 40 degrees, adjust the valve clearance of the other three cylinders according to the engine’s firing order (1 - 3 - 2 - 4) for the 4-cylinder engine.



**NOTE: When performing this maintenance, also check and re-torque head bolts to 70-90 ft-lbs as needed.**

## **4.3.2 Fuel Injection Timing**

To obtain the most economical fuel consumption, power output and to ensure normal operation of the engine, injection timing should be adjusted properly. This is set by the engine factory and should not need any adjustment under normal circumstances.

**For Model 4L22TA-1 diesel engine, injection begins at 16 degrees plus or minus 1 degree before T.D.C. (at 2350 RPM).**

If adjustment is necessary, use the following procedure to adjust injection timing:

- Vent any air trapped in the fuel system:
  - Press and release the primer pump repeatedly until resistance is felt.

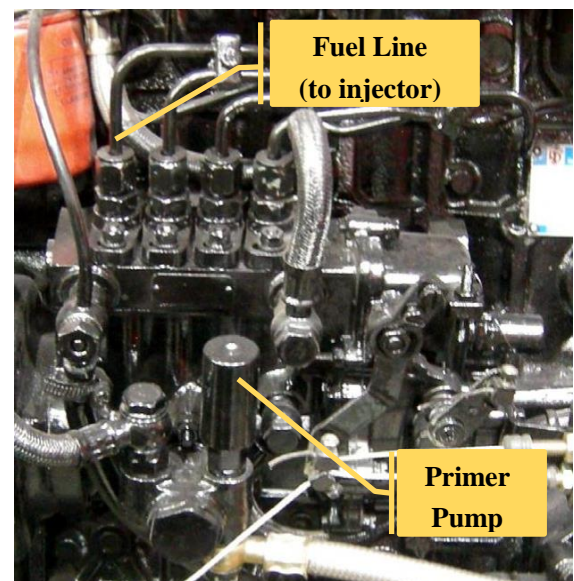

# Service

---

- Disconnect the fuel line to the first injector and pump the primer until fuel comes out of the line.
- Slowly turn the crankshaft manually in the direction of rotation while observing the fuel level in the fuel line.
  - **When fuel begins to rise, stop turning the crankshaft immediately.**
- Check the timing mark on the inspection window of the flywheel housing (as shown in the figure on the right) to see whether it aligns with the correct graduation mark of the advanced injection angle on the flywheel rim (or on the crankshaft pulley).
  - If the marks do not match-up with each other, the advanced injection angle can be adjusted by loosening the two injection pump mounting nuts and rotating the injection pump as shown in the adjacent photo.
    - If the injection timing is too advanced, rotate the injection pump counter-clockwise to the proper angle. Otherwise, rotate clockwise.

## **4.3.3 Fuel Injector Troubleshooting and Replacement**

Injector testing and adjustment must be performed by trained professionals on a calibrated injector tester in order to adjust the injector pressure, inspect spray pattern, and remedy any faults. Injector pressure that is too high or too low—or abnormal spray patterns on a damaged injector—will cause uneven fuel atomization in the cylinder.

The general symptoms of diesel engines with malfunctioning injector(s) are black exhaust smoke, a drop in engine power, increased exhaust gas temperature (engine leans), and diesel knocking.

Generally, the simplest method to identify a faulty injector is to loosen the nuts of the injector feed line one by one and observe the exhaust smoke.

- If the injector is operating normally, the engine speed will drop, however the black smoke will remain.
  - Re-tighten the fitting before testing the next injector.
- When the cylinder with the faulty injector is found, the black smoke will disappear, however the engine speed will change little or not at all.

Fuel injectors are tested and factory calibrated. If an injector is determined to be faulty, the complete injector assembly and copper sealing washer should be replaced.

### **To replace a faulty fuel injector**

- Loosen fuel line to the faulty injector at the injector end.
- Remove fuel return line from injector.
- Clean the area around the injector body to prevent any foreign matter from entering the cylinder and causing internal engine damage.
- Remove fuel injector retainer nuts.
- Slide retainer plate up and off of the injector.
- Remove injector by pulling straight upward.

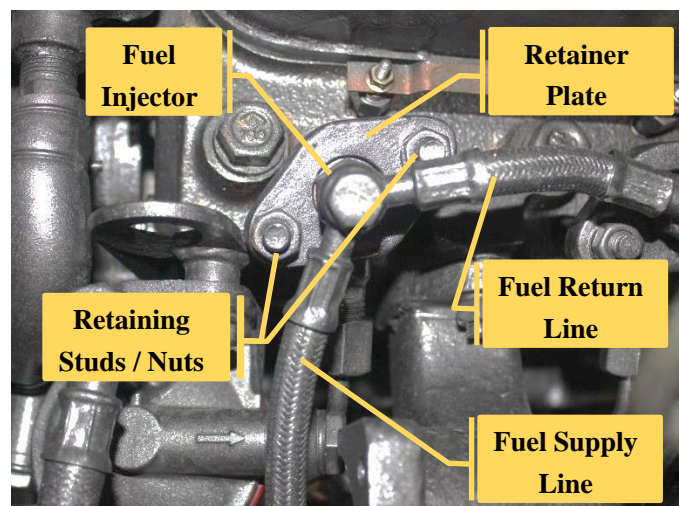

# Service

---

- If the injector is difficult to remove, tap lightly on the side of the injector body to loosen.
- Be sure to also remove the copper sealing washer found underneath the injector and replace with new sealing washer.
- Install new copper sealing washer on the new injector and insert into injector port on engine.
- Slide the retainer over the top of the injector and mounting studs.
- Install retaining nuts and tighten.
- Re-attach fuel return line, taking care not to twist the line when tightening the fitting.
- Re-install the fuel supply line and loosely install the fitting.
  - Bleed air from supply line with primer pump until fuel begins to flow from the fitting, then tighten.

## **4.3.4 Injection Pump**

The injection pump is tested and factory calibrated. If it is necessary to adjust it must be done in an injection pump test station with a known standard injector and injection plumbing. It is recommended that no attempt be made to service this part.

## **4.3.5 Engine Oil Pressure**

Engine oil pressure must be maintained within a specified range to provide proper lubrication without damaging internal seals.

With the engine oil filled to the proper level and engine at normal operating temperature, the oil pressure gauge should be steady and read between 0.2-0.5 MPa

Pressure that is either too high or too low can cause excessive engine wear and damage or total failure if critical bearing surfaces are starved of oil.

Maximum engine oil pressure is regulated by a relief valve located on the left side of the engine near the oil pressure sending unit.

**If oil pressure is not within the specified range, it can be adjusted according to the following procedure:**

- Remove the Oil Pressure Adjuster Cover Plug to access the adjusting screw located underneath.
- Using a flat-bladed screwdriver, slowly turn the adjuster, while watching the oil pressure gauge, to set the pressure within the specified range.
  - Turn the adjuster clockwise to increase pressure, or counter clockwise to reduce pressure.
  - If no change is observed in the reading when turning the screw in either direction, investigate other possible causes.
- When pressure is properly set, replace the cover plug and tighten.

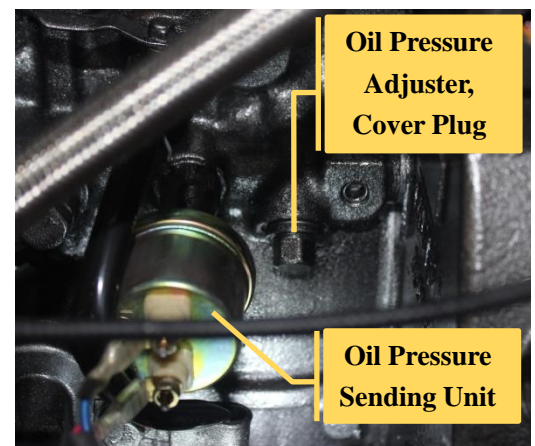

# Service

## 4.4 Driveline Servicing

This section provides transmission service procedures and is intended for use by a qualified service technician.

### **Caution!**

Before servicing the transmission, carefully review the *Maintenance Precautions* sub-section and other applicable portions of the *Safety* section of this Owner's Manual.

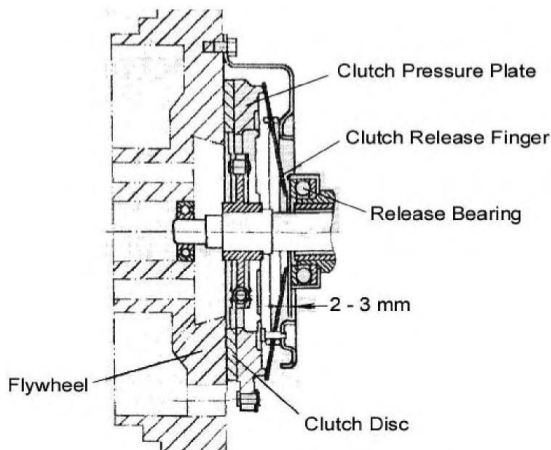

### 4.4.1 Clutch

During normal operation of the clutch, the clutch disc and pressure plate will experience wear, resulting in a gradual reduction of the clearance between the release fingers and the release bearing.

The normal clearance between the surfaces of the clutch release fingers and the clutch release bearing is 2-3 mm. See the illustration below.

Depressing the clutch pedal causes the release bearing to actuate the clutch release fingers. The amount of clutch pedal movement before resistance is felt is known as free-play. Free-play should be

maintained at ~1in. +/- 1/4" (20 – 30 mm). **See illustration.**

Free-play will decrease over time and if not adjusted, the clutch will begin to “slip”, causing heating and premature wear and failure.

**Take note of change to free-play before each use and adjust linkage and clearances as follows:**

**To adjust for clutch wear, review the description of the clutch and make the adjustments described below:**

Fully depressing the clutch pedal causes the release rocker to move until it reaches the stop bolt. This distance is the working-play. Working-play should be maintained within 4-6in. (100 – 150 mm). **See figure below.**

- Loosen lock nut on the adjusting fork.
- Turn adjusting fork to shorten or extend the push rod to adjust the free play to 20-30mm.
- Tighten lock nut on the adjusting fork.
- Loosen the lock nut on the stop bolt and adjust the stop bolt to maintain 100-150mm working play.
- Re-tighten the lock nuts on the push rod and stop bolt.

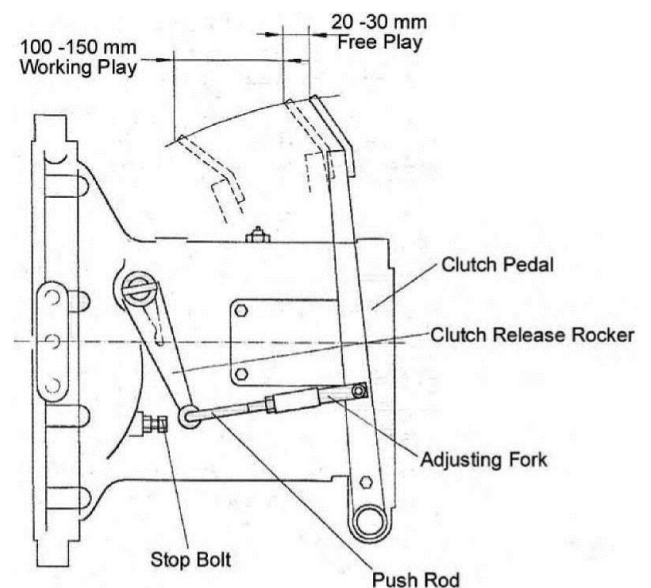

# Service

## 4.4.2 Gearbox and Main Drive

Use the instructions below to adjust the gearbox and main drive.

### First Shaft

To adjust the first shaft:

- Insert several adjusting shims between the 1st shaft front cover and the gearbox case body.
- Tighten the four bolts on the 1st shaft front cover of the gearbox case.
  - 30 – 30 Nm.
- Measure the clearance between the 1st shaft front cover and the gearbox case body with a feeler gauge. If there is no clearance, increase the number of shims of the primary shaft.
  - Decrease the number of adjusting shims of the first shaft if axial clearance appears. The proper axial clearance of the 1st shaft should be kept within the range of 0.05 – 0.10mm.

### Final Drive

The final drive is illustrated below.

To adjust the final drive,

1. Tighten the six bolts on the outer cover of the final drive case.
  - a. 30 – 35 Nm (22 – 25.8 ft.-lbs.)
2. Tighten the four bolts on the inner cover of the final drive case.
  - a. 35 – 40 Nm (25.8 – 29.5 ft.-lbs.)
3. Measure the clearance between the inner cover and the final drive case body with a feeler gauge.
  - a. Adjust quantity of shims to maintain a gap between the inner cover and the case body within a range of 0.03 – 0.10 mm.

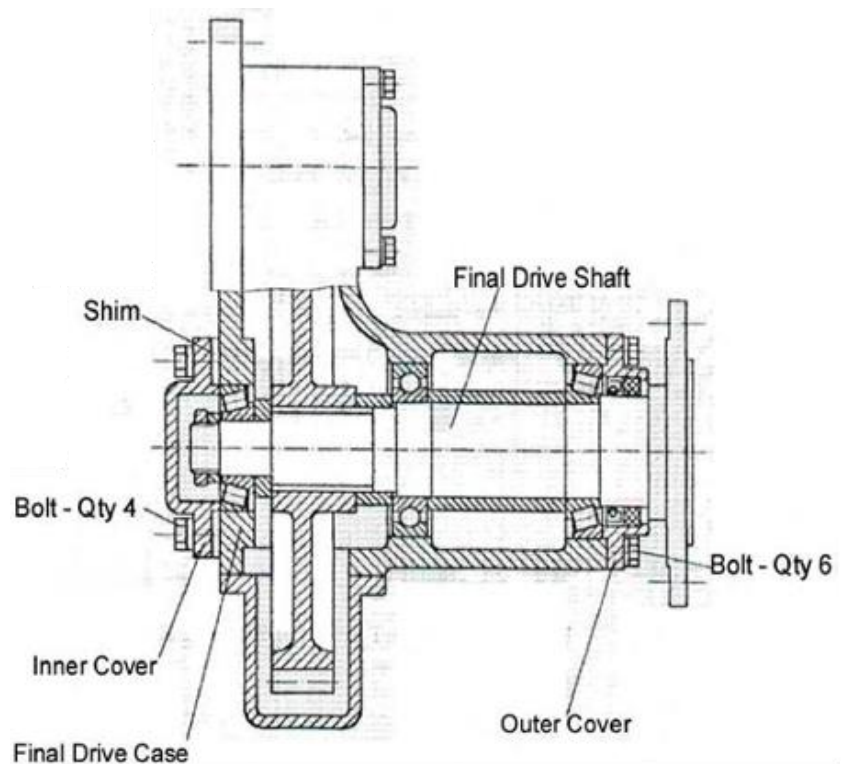

# Service

## 4.4.3 Brake and Steering Clutch Mechanism

The steering pedals are integrated with the brake pedals. Control of the brakes are operated sequentially with steering clutches and controlled with the same pedals. **Adjustment instructions refer to the diagram below.**

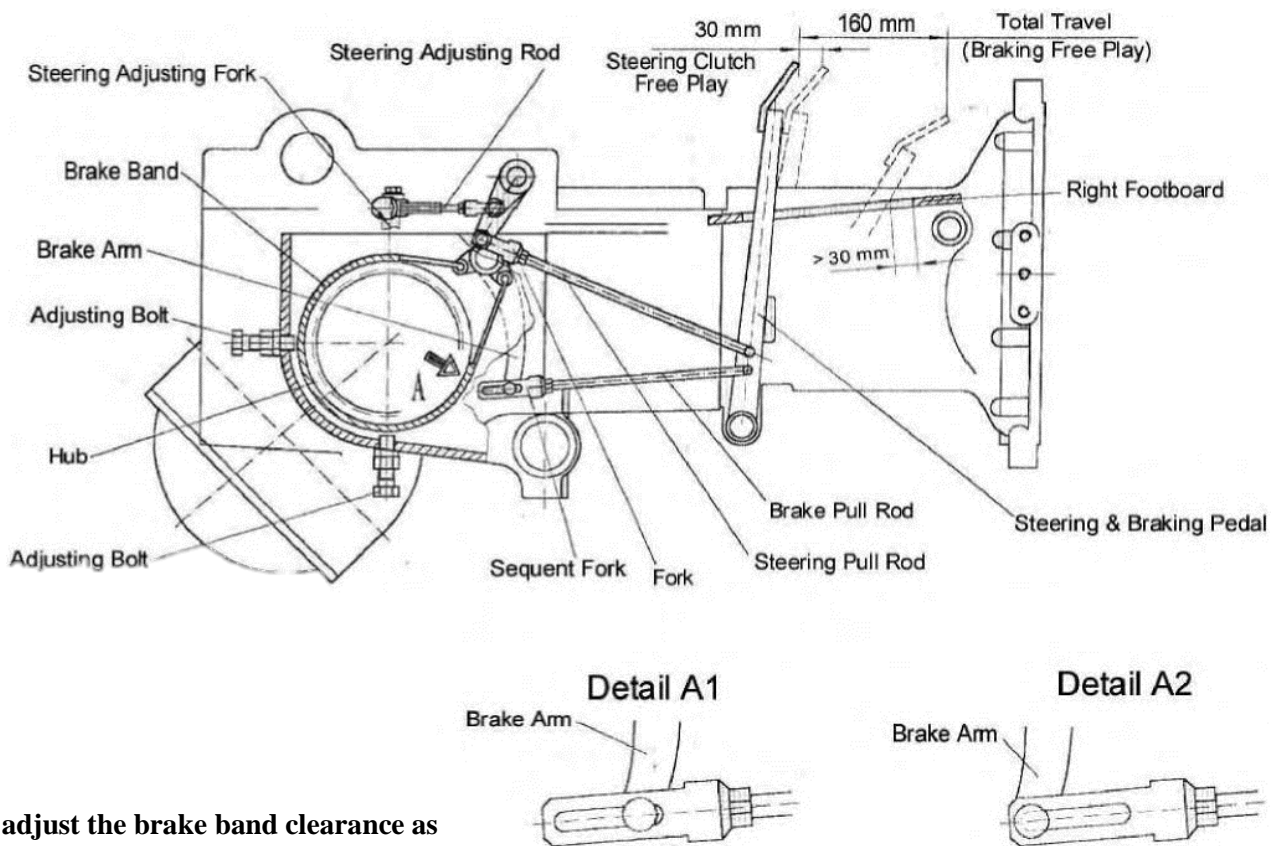

**First, adjust the brake band clearance as follows:**

- 1) Loosen the jam-nuts and turn the two adjusting bolts inward until snug; then back-out 1 turn.
  - a) This will set the clearance between the brake band and the hub to approx. 1.2 to 1.5 mm.
- 2) Lock the two bolts in position with their respective jam-nuts.
- 3) Turn the sequent fork to extend the brake pull rod until the pin on the end of the brake arm is positioned to the front of the slot. **See Detail A1 in the illustration.**

**Next, adjust the steering linkages following these steps:**

- 4) Loosen the steering linkage jam-nuts and turn the forks to adjust the length of the steering adjustment rod and steering pull rod to set steering free play to 1-1/4" (30mm) as shown at the top-right corner of the illustration.

**Finish the process by setting brake linkages to obtain correct Bottom-Free-play :**

- 5) Turn the sequent fork to shorten or extend the brake pull rod to adjust the braking bottom-free-play to 1-1/4" (30mm) as shown in the illustration's, top right corner.
- 6) Depress the brake and steering pedal completely. The clearance between the pedal arms and the slots in the dozer floorboard (right and left pedals) should exceed 1-1/4" (30 mm). Also, the pin on the end of the brake arm should

# Service

move back in the rear of the groove, as shown in Detail A2 in the illustration below.

7) Lock all nuts on the steering adjusting rod, steering pull rod and braking pull rod.

**Important:** After adjustments are properly completed, depress the brake and steering pedal completely to verify that the clutch is separated completely and the brakes are applied.

## **4.4.4 Track Tension Adjustment Procedure**

When properly adjusted, tracks should droop 0.6 - 1 in. (1.5 - 2.5cm) as measured at a point halfway between carrier roller and drive sprocket, as shown below.

**Routine maintenance should include re-adjusting track tension according to the following procedure:**

- Drive the dozer forward, stopping on hard, level ground with the lower track flat on the ground; the upper track should be slightly slack.
- Loosen the locking bolt for the adjusting screw.
- Turn the adjusting screw until the track has the proper droop; about  $\frac{3}{4}$  in. (2 cm), and then lock in place by re-tightening the locking bolt.
- If the spring cap turns together with the adjusting screw, tighten the arresting bolt into the groove of the spring cap, to prevent the spring cap from rotating.
  - After adjusting, turn the arresting bolt to its original position and lock in place with the jam nut.
- After several adjustments of the steel tracks, the idler may reach the limit of its adjustment range.
  - If this occurs, adjust the tensioner to its shortest length.
  - Remove one shoe from the track chain, and then re-adjust the track tension.

**Check and re-torque the drive sprocket mounting nuts at this time, according to the following specification; 200 ±20 foot-pounds.**

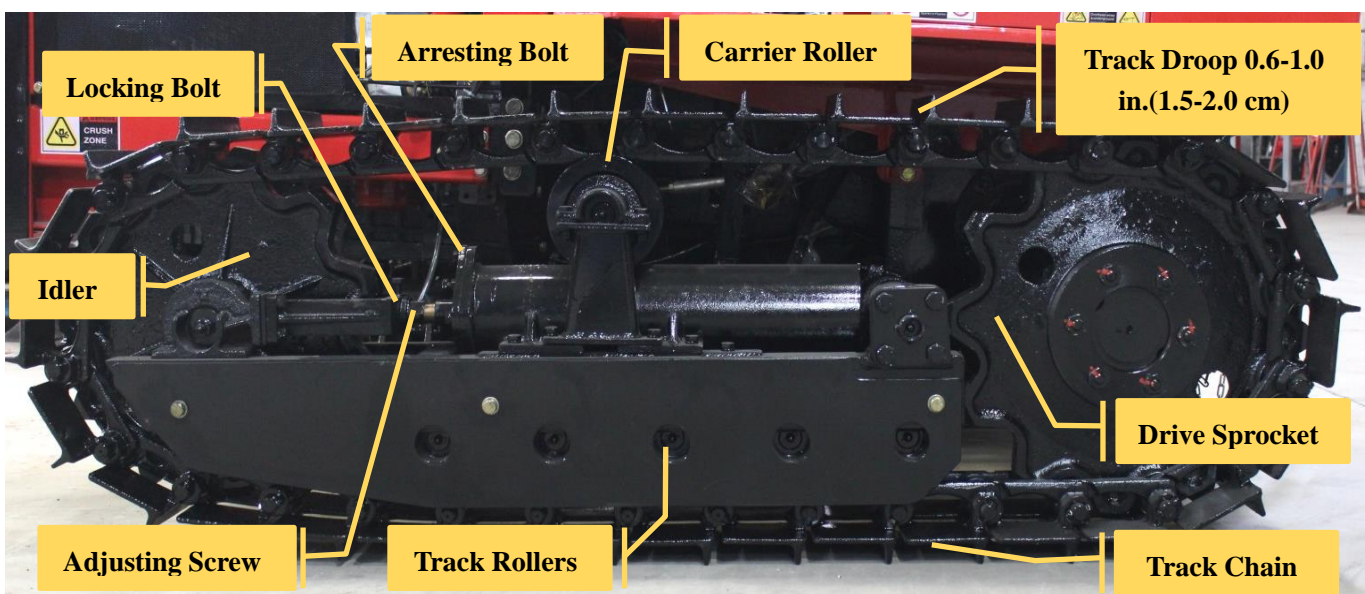

# Service

## 4.4.5 Hydraulic System

The layout of the hydraulic system is shown below.

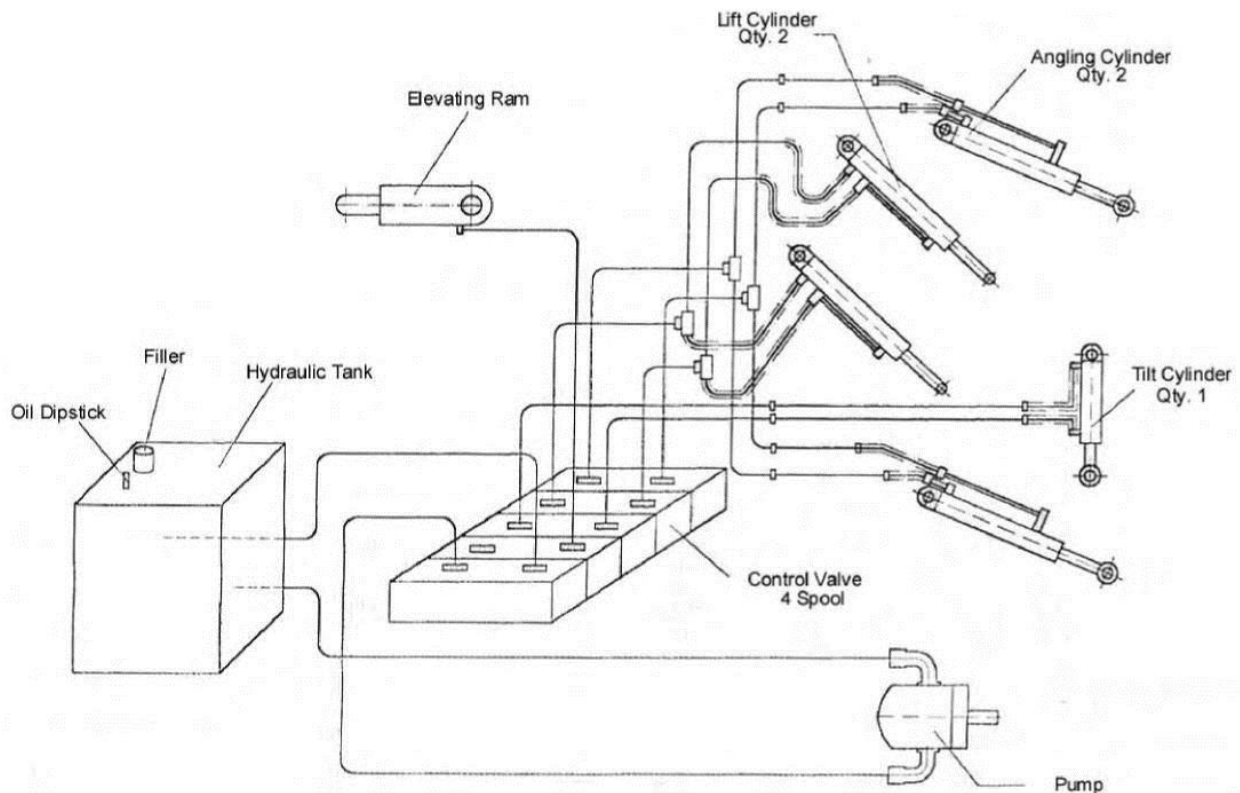

## 4.5 Electrical Servicing

### **Caution!**

Before servicing the battery or other electrical components, carefully review the *Battery Precautions* sub-section and other applicable portions of the *Safety* section of this Owner's Manual.

This sub-section describes procedures for servicing the battery and fuses on the 35XTD crawler / bulldozer.

### 4.5.1 Battery Maintenance

Follow these procedures for servicing and to extend the life of the dozer's battery:

- **Keep Terminals Clean.** Visually inspect the terminals and cables at least once a year, for signs of corrosion, especially in hot temperatures.
  - If the terminals are dirty or corroded, clean the connections with a scraper and wire brush. This will ensure a good connection and proper starting.
- **Keep Case Clean.** Keep the top of the battery clean of dirt and oil with a cloth dampened with ammonia or a 50/50 solution of baking soda and water. Rinse with clear water and allow to thoroughly dry.

# Service

---

- **Keep Battery Charged.** Batteries are designed to be charged regularly by the alternator and, if unused, will discharge slowly over time. If allowed to remain discharged, the battery will deteriorate internally and eventually fail to hold a charge. If the dozer is not used for an extended period, it may be necessary to charge the battery before use.
- **Checking Electrolyte Level.** To check the electrolyte level on a sealed battery, check the battery's built-in hydrometer. If it is green, the battery is good. If it is clear or light yellow or dark, the electrolyte level is low or the battery needs recharging.

## **4.5.2 Using Booster Cables to Jump-Start**

Take these steps when jump starting the dozer:

1. Connect one end of the positive (+) booster cable (usually red) to the booster battery's positive (+) post.
2. Connect the other end of the positive (+) booster cable to the disabled dozer battery's positive (+) post.
3. Connect one end of the negative (-) booster cable (usually black) to the booster battery's negative (-) post.
4. Connect the other end of the negative (-) booster cable to a metal part of the dozer's frame away from the battery.
5. Start the engine of the disabled dozer and run for several minutes.
6. Carefully disconnect the booster cables in the exact reverse order. (Disconnect the negative cable first and then the positive cable.)

## **4.6 Storage and Startup after Storage**

**Perform the following procedures before placing the dozer into long-term storage and when placing the machine back into service after long-term storage.**

### **4.6.1 Preparing Dozer for Long-Term Storage**

**Before placing the dozer in long-term storage, be sure it is in good operating condition as specified in this Owner's Manual. Then take the following measures:**

- Clean all external surfaces and running gear of the dozer.
- The dozer should be parked in a level, dry, secure, well ventilated area.
  - If such an area is unavailable, cover the dozer with a waterproof covering.
  - Never store the dozer around flammables or corrosive materials.
- Check the level and fill transmission and hydraulic systems as needed.
- Check anti-freeze/coolant to ensure freeze protection down to  $-35^{\circ}\text{F}$ .
- Drain the engine oil while it is hot and fill with fresh engine oil.
  - Run engine for 10 minutes at idle to allow the new engine oil to adhere to the surfaces of all the moving parts evenly.
- Lubricate to all grease fittings.
- Lower the blade and any attached implements to the ground
  - Release stored hydraulic energy by cycling the blade control and 3-point hitch controls in all directions.

# Service

---

- Remove the battery, coat the terminals posts with petroleum jelly, and keep it in dark, well-ventilated room with a consistent moderate temperature.
- Coat the electrical contacts, connectors with anti-corrosion spray.
- Loosen the fan belt on the engine and remove it if necessary.
  - Wrap the belt(s) securely and spray the pulley groove with a rust-proof agent.
- If possible, touch-up chipped/worn paint and cover non-painted metal parts with a preservative.
- Drain diesel fuel from the fuel tank or add diesel fuel conditioner to the fuel tank.
- Seal any engine opening such as intakes/outlets with protective material to prevent foreign matter, dust, and moisture from getting in.
- Place all control handles in the neutral position (including electrical system switches and the parking brake).
- Any parts removed from the dozer should be cleaned, packed and stored in a dry place.
- If possible, start the engine every three months, and allow it to run for at least 20 minutes to lubricate internal parts and ensure the battery remains charged.

## **4.6.2 Startup after Long-Term Storage**

**After extended storage, the following steps should be taken before returning the dozer to normal service:**

- Remove the corrosion preventative coating.
- Re-open the various sealed up openings and clean the dozer
- Check coolant, engine, transmission and hydraulic fluids for proper level.
- Check fuel level and condition
  - If fuel is more than 60 days old, drain and refill fuel system with fresh diesel fuel and conditioner
  - Flush the fuel system by pumping hand primer 15-25 times to circulate fresh fuel and conditioner throughout the pump, lines and injectors.
- Lubricate all grease fittings according to the provisions.
- Remove any anti-rust agent in the pulley grooves and re-install and/or adjust the fan/alternator/water pump belt. **(See: Engine Instruction for Use and Maintenance)**
- Re-install battery, check for proper electrolyte level and terminals for corrosion. Fill and clean as needed.
- Replace any other parts that may have been removed.
- Check to ensure all hoses, lines and fittings are properly connected and free of leaks.
  - Tighten, repair or replace, as needed.
- Start dozer engine and allow to warm-up at engine idle speed for 15-20 minutes.
- Check for proper operation of all electrical accessories and circuits.
- Conduct a final walk-around inspection, observing any leaks, unusual noises, or loose items.

# Diagnostics

## 5. Diagnostics

This section provides information to aid in diagnosing problems for the following systems and symptoms:

Engine:	Driveline components:	Electrical System Components:
<ul style="list-style-type: none"> <li>• Difficulty Starting</li> <li>• Low Power Output</li> <li>• Engine Quits Running</li> <li>• Abnormal Exhaust</li> <li>• Unexpected Engine Acceleration</li> <li>• Starter</li> </ul>	<ul style="list-style-type: none"> <li>• Main Clutch</li> <li>• Gearbox</li> <li>• Brake</li> <li>• Steering Clutch</li> <li>• Hydraulic Lift System</li> </ul>	<ul style="list-style-type: none"> <li>• Alternator</li> <li>• Battery</li> <li>• Accessory Systems and Dash indicator lights</li> </ul>

### 5.1 Engine

Fuel conditioner is recommended year-round regardless of temperature or conditions.

Difficult Starting		
Symptoms	Possible Cause(s)	Remedy
1. Low Ambient Temperature		<ul style="list-style-type: none"> <li>• Store indoors</li> <li>• Plug-in radiator hose heater</li> <li>• Use fuel conditioner</li> <li>• Use proper weight engine oil</li> <li>• Follow cold-weather starting instructions</li> </ul>
2. Weak Battery	<ul style="list-style-type: none"> <li>• Key switch or lights left on.</li> </ul>	<ul style="list-style-type: none"> <li>• Charge battery</li> </ul>
3. Weak Starter	<ul style="list-style-type: none"> <li>• Excessive cranking time without resting.</li> </ul>	<ul style="list-style-type: none"> <li>• Replace starter, reduce crank time</li> </ul>
4. Starter does not operate	<ul style="list-style-type: none"> <li>• Weak battery, loose or corroded cable connections</li> <li>• Loose wiring connections</li> <li>• Fuse blown –solenoid short circuit</li> <li>• Fuse blown – wiring short circuit</li> <li>• Key switch wiring damaged or defective</li> <li>• Damaged or defective solenoid</li> <li>• Starter motor windings failed</li> </ul>	<ul style="list-style-type: none"> <li>• Charge battery, clean and tighten connections</li> <li>• Inspect, clean and tighten connections at key switch, starter, battery and alternator</li> <li>• Determine cause and correct, replace fuse</li> <li>• Repair or replace wiring</li> <li>• Repair or replace wiring</li> <li>• Check and replace if necessary</li> <li>• Replace starter</li> </ul>

# Diagnostics

5. Starter turns, but will not engage engine or grinding sound is heard	<ul style="list-style-type: none"> <li>Excessive wear of starter drive gear or flywheel</li> <li>Start switch closes before starter drive gear engages flywheel</li> </ul>	<ul style="list-style-type: none"> <li>Check and replace worn parts</li> <li>Adjust</li> </ul>
6. Fuel System	<ul style="list-style-type: none"> <li>Water in fuel</li> <li>Fuel too thick</li> <li>Air in fuel system</li> <li>Defective or damaged fuel line or leak in fittings/connections</li> <li>Abnormal fuel spray pattern</li> <li>Faulty injector</li> </ul>	<ul style="list-style-type: none"> <li>Drain and refill with fresh fuel. Purge pump, lines, injectors.</li> <li>Use #1 diesel fuel when temperature is below 20<sup>0</sup>F.</li> <li>Use fuel anti-gel.</li> <li>Bleed air and check fuel line for leaks, loose fittings.</li> <li>Replace defective parts, tighten all connections.</li> <li>Add fuel injector cleaner to fuel or replace injector.</li> <li>Replace injector</li> </ul>
7. Incorrect Valve Clearance		<ul style="list-style-type: none"> <li>Check and adjust</li> </ul>
8. Fuel Injection Timing	<ul style="list-style-type: none"> <li>Timing out of adjustment</li> </ul>	<ul style="list-style-type: none"> <li>Check and adjust</li> </ul>
9. Low Cylinder Compression	<ul style="list-style-type: none"> <li>Leakage through head gasket</li> <li>Piston rings worn</li> <li>Gaps on piston rings aligned</li> <li>Piston rings stuck or broken</li> <li>Leaking valves</li> </ul>	<ul style="list-style-type: none"> <li>Check cylinder head bolt torque</li> <li>Replace cylinder head gasket</li> <li>Replace rings</li> <li>Move to 120<sup>0</sup> spacing</li> <li>Free- up or replace rings</li> <li>Repair or replace as necessary</li> </ul>

<b>Low Output Power</b>		
<b>Symptoms</b>	<b>Possible Cause(s)</b>	<b>Remedy</b>
1. Fuel Supply	<ul style="list-style-type: none"> <li>Fuel system clogged</li> <li>Primer pump worn or sticking</li> <li>Fuel pump mis-timed</li> <li>Sticking injection pump governor</li> </ul>	<ul style="list-style-type: none"> <li>Clean or replace clogged / damaged fuel lines</li> <li>Replace fuel filter</li> <li>Inspect plunger; clean or replace</li> <li>Check and adjust</li> <li>Drain old fuel, prime system with fuel conditioner, let soak, add fresh fuel</li> <li>Replace fuel injection pump</li> </ul>

# Diagnostics

	<ul style="list-style-type: none"> <li>Fuel cut-off control malfunction</li> </ul>	<ul style="list-style-type: none"> <li>Check linkage for proper operation</li> <li>Replace worn or damaged parts, lubricate and adjust</li> </ul>
--	--	---

Engine Stops Running		
Symptoms	Possible Cause(s)	Remedy
1. Engine abruptly stops	<ul style="list-style-type: none"> <li>Fuel tank empty</li> <li>No fuel delivery</li> <li>Air in fuel system</li> <li>Governor spring broken</li> <li>Sudden overload</li> <li>Component failure</li> </ul>	<ul style="list-style-type: none"> <li>Re-fill tank, prime system</li> <li>Check fuel lines and filter</li> <li>Check lines and fittings, tighten or replace. Bleed air from system</li> <li>Replace fuel injection pump</li> <li>Reduce load</li> <li>Inspect for probable causes and repair.</li> </ul>

Abnormal Exhaust		
Symptoms	Possible Cause(s)	Remedy
1. Black Smoke	<ul style="list-style-type: none"> <li>Engine overloaded</li> <li>Injector clogged</li> <li>Insufficient air supply</li> <li>Valves not adjusted properly</li> <li>Fuel injection mis-timed</li> </ul>	<ul style="list-style-type: none"> <li>Reduce load; shift to a lower gear, shift to Low range, raise blade</li> <li>Use fuel additive, clean or replace injector</li> <li>Clean/replace air filter element</li> <li>Adjust to specifications</li> <li>Set to correct timing</li> </ul>
2. Blue Smoke	<ul style="list-style-type: none"> <li>Engine oil over-filled</li> <li>Gaps on piston rings aligned</li> <li>Piston rings worn</li> <li>Valves worn</li> </ul>	<ul style="list-style-type: none"> <li>Drain to correct level per dipstick</li> <li>Move to 120<sup>0</sup> spacing</li> <li>Replace piston rings</li> <li>Repair or replace as necessary</li> </ul>
3. White Smoke	<ul style="list-style-type: none"> <li>Water in fuel</li> <li>Water in cylinder</li> <li>Dirty or defective injector(s)</li> <li>Cold engine</li> </ul>	<ul style="list-style-type: none"> <li>Drain fuel tank. Refill, add fuel conditioner</li> <li>Change fuel filter</li> <li>Re-torque cylinder head bolts</li> <li>Check cylinder head flatness</li> <li>Replace cylinder head gasket</li> <li>Clean or replace fuel injector(s)</li> <li>Allow engine to warm-up</li> </ul>

# Diagnostics

<b>Unexpected Engine Acceleration</b>		
<b>Symptoms</b>	<b>Possible Cause(s)</b>	<b>Remedy</b>
1. Engine Over-speeds	<ul style="list-style-type: none"> <li>• Throttle linkage binding</li> <li>• Governor sticking or failed</li> <li>• Engine oil over-filled</li> <li>• Engine running hot due to poor cooling system performance</li> </ul>	<ul style="list-style-type: none"> <li>• Adjust or replace linkage parts</li> <li>• Drain old fuel, prime system with fuel conditioner, let soak, add fresh fuel</li> <li>• Replace fuel pump</li> <li>• Drain to correct level per dipstick</li> <li>• Clean radiator, check fluid level, fan belt and water pump</li> </ul>

## 5.2 Driveline

<b>Clutch</b>		
<b>Symptoms</b>	<b>Possible Cause(s)</b>	<b>Remedy</b>
1. Clutch Slipping (heavy load, engine not lugging)	<ul style="list-style-type: none"> <li>• Grease or oil on clutch disk face</li> <li>• Insufficient clutch pedal free-play</li> <li>• Pressure plate warped, or worn unevenly</li> </ul>	<ul style="list-style-type: none"> <li>• Eliminate oil leak and replace disk</li> <li>• Adjust per directions</li> <li>• Replace pressure plate</li> </ul>
2. Clutch not disengaging completely, excessive noise or difficult shifting	<ul style="list-style-type: none"> <li>• Excessive clutch pedal free-play / insufficient working play</li> <li>• Pressure plate glazed</li> </ul>	<ul style="list-style-type: none"> <li>• Adjust per specifications</li> <li>• Re-surface or replace pressure plate</li> </ul>
3. Dozer vibrates severely when it begins to move	<ul style="list-style-type: none"> <li>• Clutch disk broken</li> </ul>	<ul style="list-style-type: none"> <li>• Replace clutch assembly</li> </ul>
<b>Gearbox</b>		
<b>Symptoms</b>	<b>Possible Cause(s)</b>	<b>Remedy</b>
1. Crawler stops abruptly	<ul style="list-style-type: none"> <li>• Weak gearbox self-locking spring</li> <li>• Gears not fully engaged after shifting</li> </ul>	<ul style="list-style-type: none"> <li>• Replace spring</li> <li>• Remove any obstructions to gear shift lever travel</li> <li>• Inspect shift rods and forks for proper operation</li> </ul>
2. Shifting gears is difficult or impossible	<ul style="list-style-type: none"> <li>• Clutch not completely disengaged</li> <li>• Gear edges worn, rounded or broken</li> <li>• Sliding gear binding on splined shaft</li> </ul>	<ul style="list-style-type: none"> <li>• Adjust clutch linkage per specifications</li> <li>• Inspect and replace gears as needed</li> <li>• Clean or replace gear and/or shaft</li> </ul>
3. Abnormal sounds from gearbox	<ul style="list-style-type: none"> <li>• Insufficient lubrication</li> </ul>	<ul style="list-style-type: none"> <li>• Use dipstick to check fluid level and fill to correct level</li> </ul>

# Diagnostics

	<ul style="list-style-type: none"> <li>Bearing(s) or gear(s) severely worn</li> <li>Damaged gear tooth face</li> </ul>	<ul style="list-style-type: none"> <li>Replace worn gears and/or bearings</li> <li>Replace damaged part(s)</li> </ul>
--	--	---

## Brakes

Symptoms	Possible Cause(s)	Remedy
1. Brakes not responding	<ul style="list-style-type: none"> <li>Grease or oil on brake band</li> <li>Brake band worn excessively</li> <li>Excess brake linkage free-play</li> </ul>	<ul style="list-style-type: none"> <li>Eliminate source of oil / grease and replace brake band</li> <li>Replace brake band</li> <li>Adjust linkage</li> </ul>
2. Brakes get excessively hot, not releasing	<ul style="list-style-type: none"> <li>Linkage not adjusted properly</li> <li>Return spring weak or missing</li> <li>Insufficient clearance to drum</li> </ul>	<ul style="list-style-type: none"> <li>Adjust linkage</li> <li>Replace spring</li> <li>Adjust clearance per specification</li> </ul>

## Steering Clutch

Symptoms	Possible Cause(s)	Remedy
1. Steering clutch slipping (weak traction, engine speeds up but dozer does not move faster, will not track straight)	<ul style="list-style-type: none"> <li>Grease or oil on clutch disk(s)</li> <li>Clutch disk(s) excessively worn</li> <li>Insufficient steering free-play</li> </ul>	<ul style="list-style-type: none"> <li>Eliminate source of contamination and replace disk(s)</li> <li>Replace disk(s)</li> <li>Adjust free-play per specifications</li> </ul>
2. Steering clutch does not completely disengage (cannot turn tightly)	<ul style="list-style-type: none"> <li>Excessive steering clutch free-play</li> <li>Insufficient brake free-play</li> </ul>	<ul style="list-style-type: none"> <li>Adjust per specifications</li> <li>Adjust per specifications</li> </ul>

## 3-Point Hitch Hydraulic Lift System

Symptoms	Possible Cause(s)	Remedy
1. Hitch will not raise when loaded, or raises slowly	<ul style="list-style-type: none"> <li>Low oil level in hydraulic reservoir</li> <li>Air leak in pump inlet line.</li> <li>Hydraulic filter dirty</li> <li>Oil pressure too low</li> <li>Seal damaged in cylinder</li> <li>Seal damaged in valve</li> <li>Hydraulic pump or pump drive failure</li> </ul>	<ul style="list-style-type: none"> <li>Add oil to proper level</li> <li>Tighten fittings or replace line / seals.</li> <li>Replace filter</li> <li>Adjust pressure to specification</li> <li>Replace cylinder seal</li> <li>Replace valve seal or valve assy.</li> <li>Replace pump or pump drive</li> </ul>
2. Hitch will not raise when unloaded	<ul style="list-style-type: none"> <li>See above</li> <li>Relief valve defective or leaking</li> </ul>	<ul style="list-style-type: none"> <li>See above</li> <li>Replace relief valve</li> </ul>
3. Lift will not lower	<ul style="list-style-type: none"> <li>Control valve stuck in lift position</li> </ul>	<ul style="list-style-type: none"> <li>Clean valve</li> </ul>
4. Lift jumps or vibrates while raising or lowers slowly from neutral position	<ul style="list-style-type: none"> <li>Control valve seal or sleeve worn</li> <li>Lift cylinder or seal worn</li> <li>Relief valve bypassing</li> <li>Implement too heavy</li> </ul>	<ul style="list-style-type: none"> <li>Replace parts</li> <li>Replace parts</li> <li>Replace relief valve</li> <li>Only use implements within ratings</li> </ul>

# Diagnostics

## 5.3 Electrical System

Refer to Wiring Diagram under Electrical System in the Operating Instructions section.

Troubleshooting charts for possible battery problems are listed on the next page:



### Caution!

Before performing battery troubleshooting, carefully review the **Battery Precautions** sub-section and other applicable portions of the **Safety** section of this Owner's Manual.

<b>Battery</b>		
<b>Symptoms</b>	<b>Possible Cause(s)</b>	<b>Remedy</b>
1. Insufficient Electrical Power	<ul style="list-style-type: none"> <li>• Alternator failure</li> <li>• Loose or dirty terminals / connections</li> <li>• Internal battery failure or sulfonation</li> </ul>	<ul style="list-style-type: none"> <li>• Replace alternator</li> <li>• Clean and retighten connections.</li> <li>• Use anti-corrosion coating</li> <li>• Replace battery</li> </ul>
2. Spontaneous Discharge of Battery	<ul style="list-style-type: none"> <li>• Internal battery failure</li> <li>• Starter solenoid wire short-circuit to tractor frame</li> </ul>	<ul style="list-style-type: none"> <li>• Replace battery</li> <li>• Repair or replace wire with proper insulation. Route / restrain wires to prevent damage</li> </ul>
3. Diminished Battery Charging Capacity	<ul style="list-style-type: none"> <li>• Infrequent charging of battery</li> <li>• Battery slowly discharged over extended period without recharging. Plates warped; battery will not hold a charge</li> </ul>	<ul style="list-style-type: none"> <li>• Deep cycle and slow charge to restore battery plates</li> <li>• Replace battery</li> </ul>
<b>Dash Instruments</b>		
<b>Symptoms</b>	<b>Possible Cause(s)</b>	<b>Remedy</b>
1. Indicator light(s) not working	<ul style="list-style-type: none"> <li>• Bulb failed</li> <li>• Power to bulb socket, poor ground</li> <li>• Loose or broken wire</li> <li>• Fuse failed</li> <li>• Dash switch failed</li> </ul>	<ul style="list-style-type: none"> <li>• Replace bulb</li> <li>• Clean ground points and tighten connections</li> <li>• Tighten or repair/replace wire</li> <li>• Replace fuse</li> <li>• Replace faulty switch</li> </ul>

# Diagnostics

<b>Alternator</b>		
<b>Symptoms</b>	<b>Possible Cause(s)</b>	<b>Remedy</b>
1. Low / No output current or voltage	<ul style="list-style-type: none"> <li>• Connecting wires loose or broken</li> <li>• Diode failed</li> <li>• Internal alternator windings failed</li> <li>• Output voltage – below specification</li> <li>• Voltage regulator failed</li> <li>• Ammeter in dash panel does not indicate system is charging</li> <li>• Alternator drive belt loose</li> </ul>	<ul style="list-style-type: none"> <li>• Tighten, repair or replace wiring</li> <li>• Replace alternator</li> <li>• Replace alternator</li> <li>• Replace voltage regulator</li> <li>• Replace voltage regulator</li> <li>• Check wiring connections in dash</li> <li>• Replace gauge</li> <li>• Adjust belt tension to specifications</li> </ul>
2. Unstable output current / voltage	<ul style="list-style-type: none"> <li>• Alternator drive belt loose</li> <li>• Internal windings failing</li> <li>• Voltage regulator failing</li> </ul>	<ul style="list-style-type: none"> <li>• Clean belt and adjust belt tension. (See <i>Every 50 Hours of Operation</i> under <i>Service Intervals</i> in the <i>Service</i> section.)</li> <li>• Replace alternator</li> <li>• Replace voltage regulator</li> </ul>
3. Abnormal sounds or smells from alternator	<ul style="list-style-type: none"> <li>• Improper mounting or interference from rotating parts</li> <li>• Bearings failing</li> <li>• Internal parts rubbing together</li> <li>• Voltage regulator failed – voltage too high</li> </ul>	<ul style="list-style-type: none"> <li>• Find and correct interference. Check alternator guard</li> <li>• Replace alternator</li> <li>• Replace alternator</li> <li>• Replace voltage regulator</li> </ul>
4. Ammeter indicates excessive charging level	<ul style="list-style-type: none"> <li>• Battery shorted</li> <li>• Voltage regulator output too high</li> <li>• Poor ground to voltage regulator</li> <li>• Voltage regulator terminals dirty</li> </ul>	<ul style="list-style-type: none"> <li>• Replace battery</li> <li>• Replace voltage regulator</li> <li>• Clean and retighten ground wire</li> <li>• Clean and retighten connections</li> </ul>

# Dimensions and Specifications

## 6. Dimensions and Specifications

The following section contains dimensional and performance information and specifications for the 35XTD crawler/bulldozer:

### 6.1 Overall Machine Design Information and Specifications

<p><b>Dimensions in. (mm)</b></p> <ul style="list-style-type: none"> <li>• Overall length with blade</li> <li>• Overall width (blade width, straight)</li> <li>• Height of blade</li> <li>• Crawler width (no blade)</li> <li>• Track length on ground</li> <li>• Track Width</li> <li>• Ground clearance</li> <li>• Overall height to top of ROPS</li> <li>• Blade lift height</li> <li>• Digging Depth</li> </ul>	<p>116.54 (2960)</p> <p>64.5 (1638)</p> <p>26.5 (673)</p> <p>64.5 (1638)</p> <p>43.3 (1100)</p> <p>10.25 (260)</p> <p>9.45 (240)</p> <p>90 (2286)</p> <p>19.63 (500)</p> <p>3.1 (80)</p>		
<p><b>Design Speeds in Gears: mph (km/h)</b> (@ maximum power output)</p>	<p><b>Gear</b></p>	<p><b>Low Range</b></p>	<p><b>High Range</b></p>
	<p><b>Reverse</b></p>	<p>0.48 (0.77)</p>	<p>1.90 (3.05)</p>
	<p><b>1<sup>st</sup> gear</b></p>	<p>0.51 (0.81)</p>	<p>2.00 (3.23)</p>
	<p><b>2<sup>nd</sup> gear</b></p>	<p>0.65 (1.04)</p>	<p>2.53 (4.07)</p>
	<p><b>3<sup>rd</sup> gear</b></p>	<p>1.05 (1.69)</p>	<p>4.12 (6.63)</p>
	<p><b>4<sup>th</sup> gear</b></p>	<p>1.67 (2.68)</p>	<p>6.53 (10.51)</p>
<p><b>Performance Data</b></p> <ul style="list-style-type: none"> <li>• Operating Weight: lb. (kg)</li> <li>• Maximum Drawbar Pull: lb (kg)</li> <li>• Blade Capacity: yd<sup>3</sup> (m<sup>3</sup>)</li> </ul>	<p>6150 (2790)</p> <p>5180 (2350)</p> <p>.876 (.67)</p>		
<p><b>Drivetrain</b></p> <ul style="list-style-type: none"> <li>• Main clutch</li> <li>• Gearbox</li> <li>• Main drive</li> <li>• Final drive</li> </ul>	<p>Single dry disk diaphragm-spring clutch, 10” pedal control</p> <p>2-shaft, 8 forward, 2 reverse, sliding gear shift</p> <p>Spiral bevel</p> <p>Externally meshed spur gear</p>		

# Dimensions and Specifications

<p><b>Steering and brakes</b></p> <p>Steering pedals integrated with brake pedals.</p> <ul style="list-style-type: none"> <li>Steering clutches</li> <li>Brakes</li> </ul>	<p>Multiple dry cerametallic disk clutches, pedal control</p> <p>Band brakes, pedal control</p>
<p><b>Under Carriage</b></p> <ul style="list-style-type: none"> <li>Frame design</li> <li>Track rollers (per side)</li> <li>Track recoil system</li> <li>Track shoes: qty/side), width: in. (mm)</li> </ul>	<p>Semi-rigid</p> <p>5 + 1</p> <p>Helical spring, screw adjusted</p> <p>32, 10 ¼ (260)</p>
<p><b>Hydraulic Systems</b></p> <p>(Blade, 3-point hitch lift)</p> <ul style="list-style-type: none"> <li>Pump type / model</li> <li>Flow at rated engine rpm: gpm (lpm)</li> <li>Relief valve pressure: psi (MPa)</li> <li>Control valve</li> <li>Blade functions</li> <li>Blade cylinders</li> <li>Blade lift: qty, bore/stroke in. (mm)</li> <li>Blade angle: qty, stroke/bore in. (mm)</li> <li>Blade tilt: qty, stroke/bore in. (mm)</li> <li>3-Point hitch linkage</li> <li>3-Point hitch lift control</li> <li>3-Point hitch lift cylinder</li> <li>3-Point lift cyl.: bore/stroke in (mm)</li> <li>3 Point hitch lift capacity: lbs (kg)</li> </ul>	<p>Gear type, CBJ30-F12</p> <p>6.6 (25.2) @ 2200 rpm</p> <p>2230 (16)</p> <p>4-spool (3 blade control, 1 3-Point hitch control)</p> <p><b>Lift:</b> Raise-Hold-Lower-Float</p> <p><b>Angle:</b> Right – Hold – Left</p> <p><b>Tilt:</b> Clockwise – Hold – Counter-Clockwise</p> <p>Double-Acting</p> <p>2 ea., 2.5 x 11.25 (63 x 285)</p> <p>2 ea., 2.5 x 11.00 (63 x 280)</p> <p>1 ea., 2.5 x 2.00 (63 x 50)</p> <p>Rear, Category 1</p> <p>Raise – Hold – Lower (float)</p> <p>Single-acting</p> <p>1 ea., 3.15 x 3.95 (80 x 100)</p> <p>1650 lbs (750)</p>
<p><b>Power Take-off (PTO)</b></p> <ul style="list-style-type: none"> <li>Type</li> <li>Speeds @ engine rpm</li> <li>Shaft specification</li> </ul>	<p>Mechanical, dependent engagement</p> <p>540 rpm @ 1812 rpm, 720 rpm @ 1772 rpm</p> <p>1-3/8 diameter 6 spline</p>
<p><b>Electrical system</b></p> <ul style="list-style-type: none"> <li>Voltage</li> <li>Alternator (internal rectified)</li> <li>Starter</li> <li>Battery</li> </ul>	<p>12V, negative ground</p> <p>200W</p> <p>3 kW</p> <p>850 CCA, Maintenance free</p>

# Dimensions and Specifications

<ul style="list-style-type: none"> <li>• Headlights</li> <li>• Work lights</li> </ul>	<p>2 ea., 55W</p> <p>2 ea. front, 2 ea. rear, 55W</p>
<b>Capacities</b> <ul style="list-style-type: none"> <li>• Fuel: gal. (liter)</li> <li>• Engine Oil: qt. (liter)</li> <li>• Transmission: qt. (liter)</li> <li>• Hydraulic reservoir: qt. (liter)</li> <li>• Final drives: qt. (liter)</li> <li>• Radiator (coolant): qt. (liter)</li> </ul>	<p>7.4 (28)</p> <p>6 (5.7)</p> <p>11.6 (11)</p> <p>27.2 (25.8)</p> <p>2 (1.9)</p> <p>9.4 (8.7)</p>

Engine Specifications – Design and performance data	
<b>Model</b> <ul style="list-style-type: none"> <li>• Type</li> <li>• # cylinders, displacement in<sup>3</sup> (L)</li> <li>• Bore x Stroke: in. (mm)</li> <li>• Compression ratio</li> <li>• Maximum power: hp (kW) @ rpm</li> <li>• Maximum torque: ft-lbs (Nm) @ rpm</li> <li>• Optimum fuel consumption (g/kWh)</li> <li>• Fuel</li> <li>• Lubrication</li> </ul>	<p><b>4L22TA-1</b></p> <p>Vertical, water-cooled, four stroke, direct injection</p> <p>4, 136 (2.16)</p> <p>3.74 x 4.13 (85 x 95)</p> <p>18 : 1</p> <p>34.5 (25.7) @ 2350</p> <p>89.25 (121) @1400</p> <p>243</p> <p>Diesel</p> <p>Full pressure, internal gear pump</p>
Engine Specifications – Technical, torque, clearance and wear limit data	
<b>Valve Clearance (cold)</b> <ul style="list-style-type: none"> <li>• Intake: in. (mm)</li> <li>• Exhaust: in. (mm)</li> </ul> <b>Valve Timing</b> <ul style="list-style-type: none"> <li>• Intake Valve – Open</li> <li>• Exhaust Valve – Open</li> <li>• Intake Valve – Close</li> <li>• Exhaust Valve - Close</li> </ul>	<p>0.007 – 0.009 (0.20 – 0.25)</p> <p>0.009 – 0.011 (0.25 – 0.30)</p> <p>8<sup>0</sup> CA Before TDC</p> <p>52<sup>0</sup> CA Before TDC</p> <p>52<sup>0</sup> CA After TDC</p> <p>8<sup>0</sup> CA After TDC</p>
<b>Fuel Injection System</b> <ul style="list-style-type: none"> <li>• Injection Pressure</li> <li>• Fuel Supply Advanced Angle</li> </ul>	<p>1.95 x 10<sup>3</sup> – 1.9 x 10<sup>4</sup> Kpa</p> <p>20+/- 10 CA</p>
<b>Net Weight lbs (kg)</b>	530 (240)
<b>Overall Dimensions L x W x H in (mm)</b>	26.2 x 19.7 x 26.7 (666 x 500 x 678)
<b>Oil Filter</b>	FC4L2209305 or WB477

# Dimensions and Specifications

<b>Fuel Filter</b>	FCKW200701
<b>Key Torque Specifications</b>	
<ul style="list-style-type: none"> <li>• Connecting Rod Bolt</li> <li>• Cylinder Head Bolt</li> <li>• Main Bearing Bolt</li> <li>• Flywheel Bolt</li> </ul>	<p>90 ~ 100 NM - 66 ~ 73.75 foot pounds</p> <p>120 ~ 135 NM - 88.5 ~ 99.5 foot pounds</p> <p>150 ~ 160 NM - 110 ~ 118 foot pounds</p> <p>90 ~ 110 NM - 66 ~ 81 foot pounds</p>

## 6.2 Crawler Bolt Torque Specification

<b>General Torque Specifications</b>	1 Nm = 0.74 lb-ft.		
<b>Bolts</b>			
<b>Thread diameter of bolt (mm)</b>	<b>Width across flat (mm)</b>	<b>Nm</b>	<b>Lb-ft</b>
6	10		
8	13	13 +/- 2	9.6 +/- 2
10	17	30 +/- 3	22 +/- 3
12	19	65 +/- 7	48 +/- 5
14	22	110 +/- 10	80 +/- 7
16	24	180 +/- 20	130 +/- 15
18	27	280 +/- 30	200 +/- 20
20	30	380 +/- 40	280 +/- 30
		550 +/- 60	400 +/- 40
<b>Nuts</b>			
Drive sprocket mounting nuts should be torqued to 200 +/- 20 lb-ft (280 +/- 30 Nm)			

## 6.3 Engine Parts - Fitted Clearances and Wear Limits

Fitted Parts	Hole Axle	Type of Fit	Recommended Clearance	Wear Limit
Connecting Rod Bearing Crankpin	+0.07 +0.04 Φ61----- 0.0 -0.019	Clearance	0.04 ~ 0.089	0.20
Connecting Rod Small End Bushing	+0.025 +0.0 Φ39----- 0.043 -0.068	Interference	-0.068 ~ -0.018	

# Dimensions and Specifications

Fitted Parts	Hole Axle	Type of Fit	Recommended Clearance	Wear Limit
Opening of Crankpin Connecting Rod Big End	+0.10 +0.0 38----- 0.17 -0.27	Clearance	0.17 ~ 0.37	0.50
Connecting Rod Bushing Piston Pin	+0.041 +0.025 Φ35----- 0.0 -0.011	Clearance	0.025 ~ 0.052	0.12
Piston Ring Groove 1st Piston Ring	+0.08 +0.06 2.5----- 0.0 -0.012	Clearance	0.06 ~ 0.092	0.18
Piston Ring Groove 2nd Piston Ring	+0.08 +0.06 2.5----- 0.0 -0.012	Clearance	0.06 ~ 0.092	0.15
Piston Ring Groove Oil Ring	+0.05 +0.03 5----- 0.0 -0.012	Clearance	0.03 ~ 0.062	0.15
Piston Ring Open Clearance (Measured by Ö95.035) 1st Piston Ring 2nd Piston Ring Oil Ring			0.30 ~ 0.45 0.25 ~ 0.40 0.25 ~ 0.45	2.5 2.5 2.5
Main Bearing Shell Crankshaft Main Bearing	+0.013 +0.10 Φ75----- 0.0 -0.019	Clearance	0.010 ~ 0.149	0.25
Front Camshaft Bushing Camshaft Front Neck	+0.030 +0.0 Φ55----- 0.06 -0.09	Clearance	0.06 ~ 0.12	0.25

# Dimensions and Specifications

Fitted Parts	Hole Axle	Type of Fit	Recommended Clearance	Wear Limit
Middle Camshaft Bushing Camshaft Middle Neck	+0.030 +0.0 Φ54 ----- -0.06 -0.09	Clearance	0.06 ~ 0.12	0.25
Rear Camshaft Bushing Camshaft Rear Neck	+0.025 +0.0 Φ45 ----- -0.05 -0.075	Clearance	-0.05 ~ -0.10	0.25
Hole in Cylinder Block Tappet	+0.018 +0.0 Φ16 -0.016 -0.034	Clearance	0.016 ~ 0.052	0.20
Bushing Idle Gear Shaft	+0.025 +0.0 Φ44 ----- -0.009 -0.025	Clearance	0.009 ~ 0.05	0.5
Valve Guide Valve Rod	+0.025 +0.00 Φ9 ----- -0.05 -0.07	Clearance	0.05 ~ 0.092	0.20
Axial Clearance of Camshaft			0.07 ~ 0.175	0.30
Axial Clearance of Crankshaft			0.018 ~ 0.028	0.40
Cylinder liner protruding from top surface of cylinder block	+0.058 Cylinder Block 10+0.00 Cylinder Liner 10 +0.12 +0.08		0.022 ~ 0.012 Over the same engine <0.05	
Sinking of Valves			0.6 ~ 0.9	1.8
Rocker Arm Bushing Rocker Arm Shaft	+0.043 +0.016 Φ16 ----- 0.0 -0.011	Clearance	0.043 ~ 0.054	0.20

## End of Owner's Section

# Parts Breakdown - Chassis

---

## NorTrac 35XTD Crawler-Dozer: Item# 24549 - Chassis

Fig.1 Diesel engine assembly & accessories .....	76
Fig.2 Engine throttle assembly .....	77
Fig.3 Engine shut-down assembly .....	78
Fig.4 Clutch housing assembly (I).....	79
Fig.5 Clutch housing assembly (II) .....	81
Fig.6 Undercarriage frame assembly .....	82
Fig.7 Swing shaft.....	83
Fig.8 Track Tensioner Assembly .....	84
Fig.9 drive sprocket, guiding wheel and track shoe .....	85
Fig.10 Track roller assembly .....	86
Fig.11 Transmission case.....	87
Fig.12 Fork & fork shaft.....	89
Fig.13 PTO control assembly .....	90
Fig.14 Transmission case cover assembly .....	91
Fig.15 transmission case shift (I).....	92
Fig.16 Transmission case Shaft II.....	93
Fig.17 PTO shaft.....	95
Fig.18 Reverse shaft assembly .....	96
Fig.19 Central transmission.....	97
Fig.20 Steering clutch assembly.....	98
Fig.21 Steering clutch housing assembly .....	99
Fig.22 Final drive housing assembly .....	100
Fig.23 Final drive .....	101
Fig.24 Steering clutch control assembly.....	102
Fig.25 Brake assembly (I) .....	104
Fig.26 Brake assembly (II) .....	105
Fig.27 Operator's seat.....	106
Fig.28 Canopy assembly.....	107

# Parts Breakdown - Chassis

---

Fig.29 Engine hood assembly .....	108
Fig.30 Left side block assembly .....	110
Fig.31 right side block assembly .....	111
Fig.32 Transom.....	113
Fig.33 Electrical system and instrumentation.....	114
Fig.34 Fuel tank assembly .....	116
Fig.35 3-Point hitch hydraulic lifter .....	117
Fig.36 Three-point hitch linkage and traction mechanism assembly.....	118
Fig.37 Hydraulic control lever - STRAIGHT BLADE .....	120
Fig.38 Six-action Blade - STRAIGHT BLADE.....	122
Fig.39 blade bracket .....	123
Fig.40 Hydraulic tank and lines.....	124
Fig.41 Hand brake .....	125

# Parts Breakdown - Chassis

**Fig.1 Diesel engine assembly & accessories**

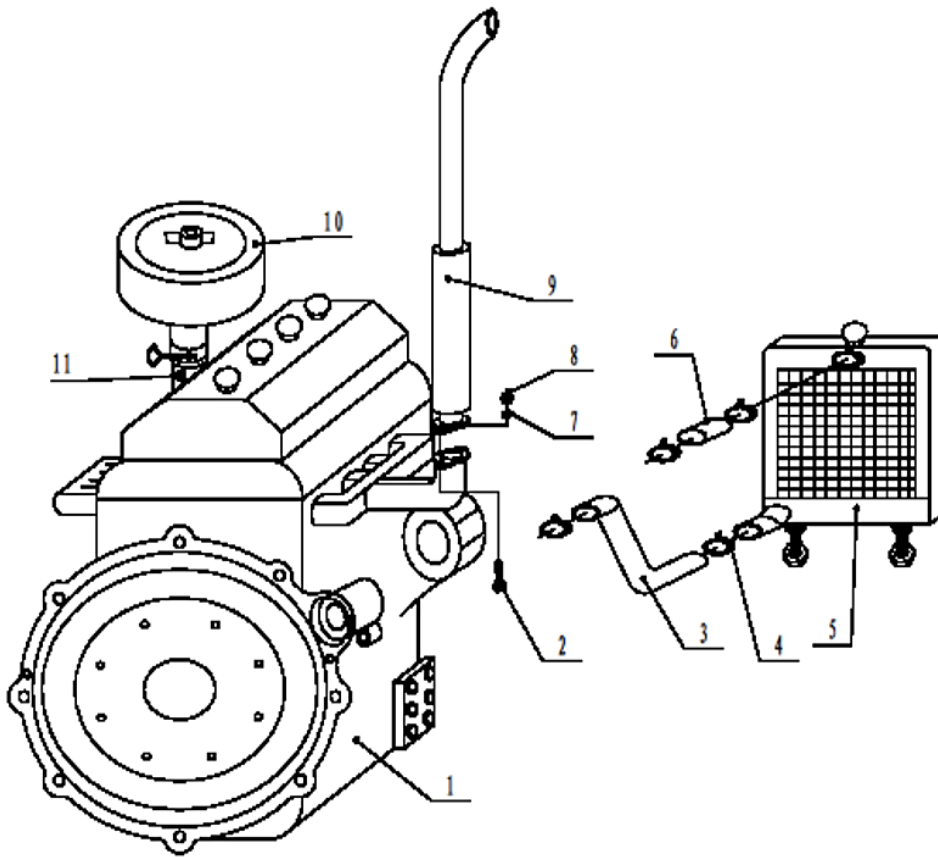

Fig#	Ref#	Mfg. Part#	NTE Part#	Description	Qty
1	1	4L22TA-265	FC4L22TA265	Diesel engine	1
1	2	GB/T5783-		bolt M12x35	2
1	3	328B-0200002	FC328B0200002	Sewer pipe	1
1	4	ZBT32001.1-88		clip 2# (38-57)	4
1	5	330-0201000	FC3300201000	radiator	1
1	6	330E-0200002	FC330E0200002	Potable water pipe	1
1	7	GB93-10		washer 10	2
1	8	GB6170-M10		nut M10	2
1	9*	330-0101000	FC3300101000	Muffler – 2 bolt. Mfg. before 8/2014	1
1	9*	LD485-0101000	FCLD4850101000	Muffler – 4 bolt. Mfg. after 8/2014	1
1	10	KW2007	FCKW2007	Air filter assembly	1
1	10.1	KW2007-01	FCKW200701	Air filter element	1
1	11	335A-0100010		Air filter elbow	1
1	n/a	335A-0100020	FC335A0100020	Exhaust Extension (2 bolt). Mfg. before 8/2014	1
1	n/a		FCLD4850100020	Exhaust Extension (4 bolt). Mfg. after 8/2014	1

# Parts Breakdown - Chassis

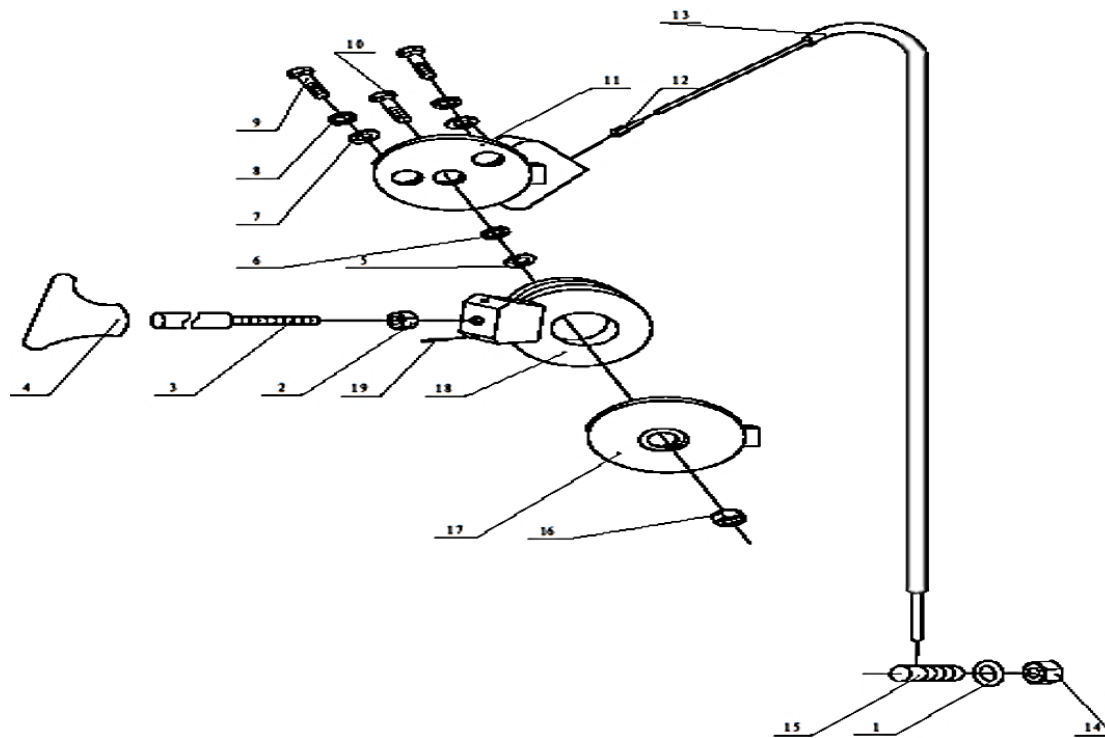
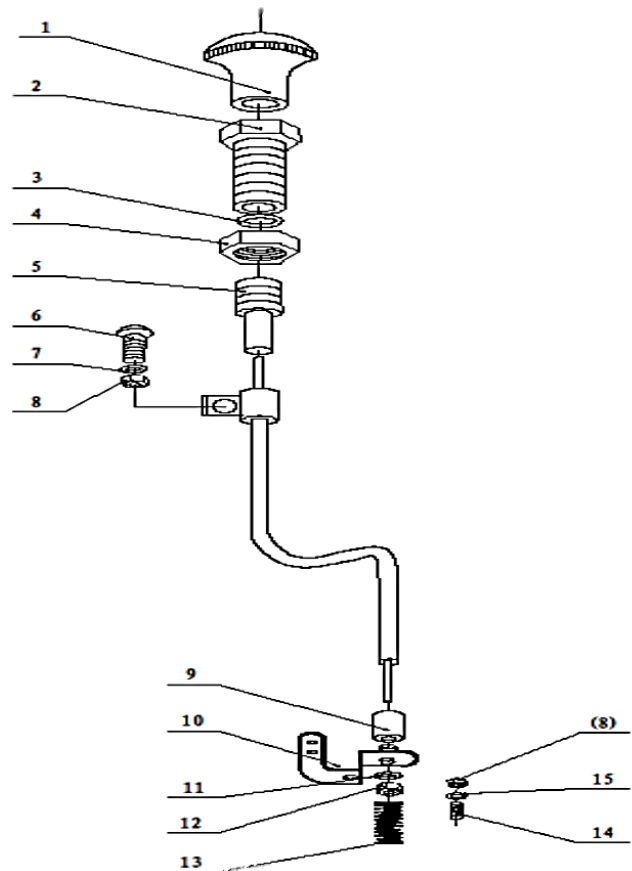

**Fig.2 Engine  
throttle  
assembly**

Fig#	Ref#	Mfg. Part#	NTE Part#	Description	Qty
2	1	GB96-6-A140HV		washer 6-A140HV	3
2	2	GB6170-M10		nut M10	1
2	3	252L-4.20.101	FC252L420101	handle pole	1
2	4	302L-5.20.211	FC302L520211	Throttle handle	1
2	5	252L-4.20.108		washer	1
2	6	252L-4.20.109		washer	1
2	7	GB97.1-8-140HV		washer 8-140HV	2
2	8	GB93-8		washer 8	2
2	9	GB5782-M8x15		bolt M8x15	2
2	10	GB5782-M8x30		Bolt M8x30	1
2	11	252L-4.20.105	FC252L420105	pedestal	1
2	12	252L-4.20.106		line base	1
2	13	252L-4.20.107	FC252L420107	Throttle cable subassembly	1
2	14	GB6170-M6		nut M6	1
2	15	252L-4.20.110	FC252L420110	screw M6x16	1
2	16	GB6170-M8	FCGB6170M8	Nut M8	1
2	17	252L-4.20.104		impact cover	1
2	18	252L-4.20.011	FC252L420011	swivel weldment	1
2	19	GB67-M6x10		screw M6x10	1

# Parts Breakdown - Chassis

Fig.3 Engine shut-down assembly



Fig#	Ref#	Mfg. Part#	NTE Part#	Description	Qty
3	1	302-6.20.500		drawing button	1
3	2	302-6.20.501		pulling rod base	1
3	3	GB93-12		washer 12	1
3	4	GB6170-M12		nut M12	1
3	5	302-6.20.020	FC302620020	Fuel cut-off line assembly	1
3	6	GB818-M6x16	FCGB818M616	screw M6x16	1
3	7	GB93-6		washer 6	1
3	8	GB6170-M6		nut M6	2
3	9	302-6.20.112	FC302620112	line pedestal	1
3	10	335A-0600001		support bracket	1
3	11	GB93-8		washer 8	1
3	12	GB6170-M8	FCGB6170M8	nut M8	1
3	13	302-6.20.505	FC302620505	spring	1
3	14	252L-4.20.110	FC252L420110	screw M6x16	1
3	15	GB97.1-6		washer 6	1

# Parts Breakdown - Chassis

Fig.4 Clutch housing assembly (I)

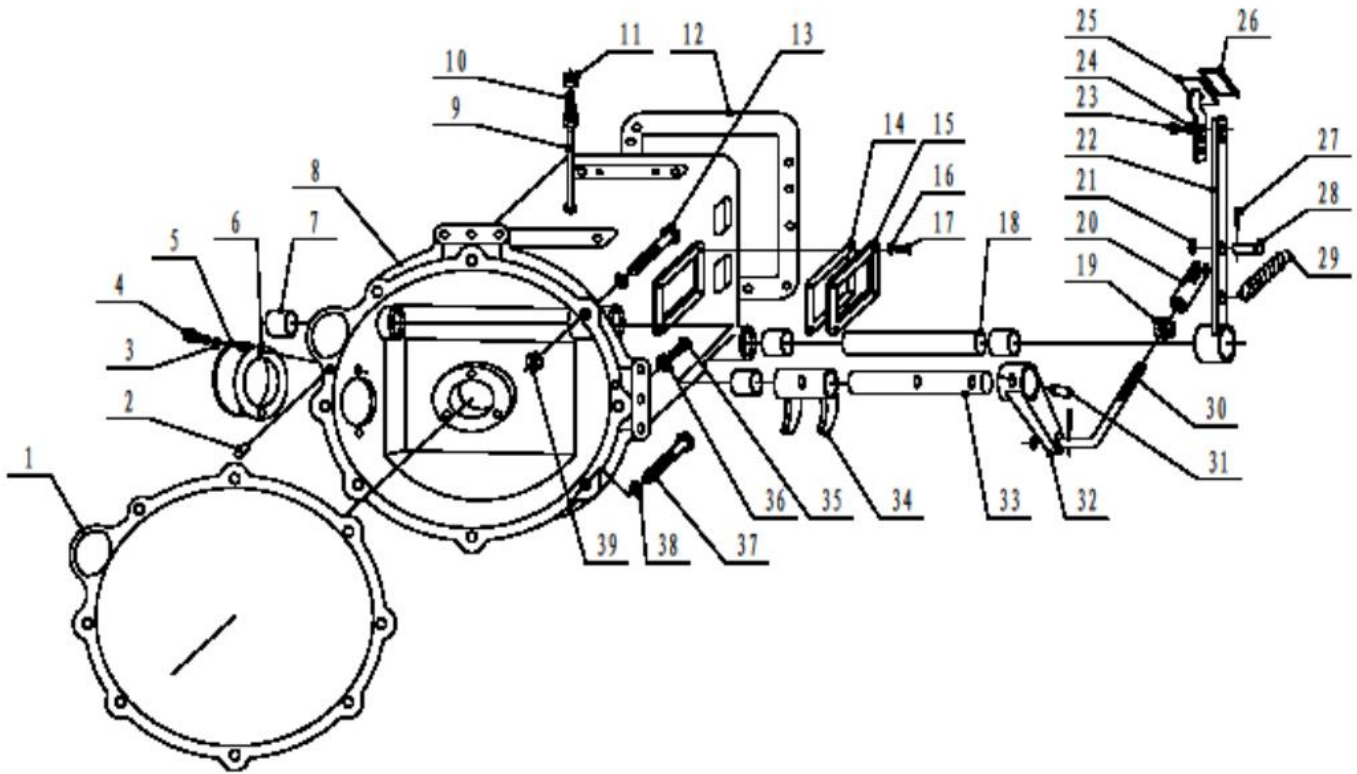

Fig#	Ref#	Mfg. Part#	NTE Part#	Description	Qty
4	1	252L.21.522F	FC252L21522F	paper gasket	1
4	2	GB/T119.2-A12x24	FCGBT1192A1224	pin A12x24	2
4	3	GB93-10		washer 10	2
4	4	GB5782-M10x20		Bolt M10x20	2
4	5	252L.21.524		cap	1
4	6	252L.21.523	FC252L21523	cap paper gasket	1
4	7	252L.21.136A	FC252L21136A	bushing	4
4	8	252L.21.501F	FC252L21501F	clutch housing	1
4	9	302L-5.21.600	FC302L521600	hose, release bearing	1
4	10	GB1152-M6x1	FCGB1152M61	grease cup M6x1	1
4	11	GB6172-M16		nut M16	1
4	12	252L.21.140	FC252L21140	paper gasket	1
4	13	GB5782-M12x80		bolt M12x80	5
4	14	252L.21.113	FC252L21113	paper gasket	1
4	15	252L.21.112		cover plate	1
4	16	GB93-8		washer 8	4

# Parts Breakdown - Chassis

Fig#	Ref#	Mfg. Part#	NTE Part#	Description	Qty
4	17	GB5783-M8x20		Bolt M8x20	4
4	18	252L.43.102	FC252L43102	pedal shaft	1
4	19	GB6170-M10		nut M10	1
4	20	252L.21.107	FC252L21107	adjusting fork	1
4	21	GB97.1-8		washer 8	2
4	22	330A3-0701000		Lever weldment	1
4	23	GB5781-M8x20		bolt M8x20	2
4	24	GB93-8		washer 8	2
4	25	330E-1503110		pedal	1
4	26	525-1803001	FC5251803001	rubber pad	1
4	27	GB91-2x20	FCGB91220	Cotter pin 2x20	2
4	28	GB882-B8x30	FCGB882B830	pin 8Bx30	1
4	29	252L.21.110	FC252L21110	return spring of pedal	1
4	30	252L.21.502		clutch pushing rod	1
4	31	GB879-8x40	FCGB879840	pin 8x40	2
4	32	252L.21.105A	FC252L21105A	release rocker for clutch	1
4	33	252L.21.103	FC252L21103	shaft for clutch release fork	1
4	34	402.21.602	FC40221602	clutch release yoke	1
4	35	GB5781-M10x45		bolt M10x45	1
4	36	GB6170-M10		nut M10	1
4	37	GB5782-M12x70		bolt M12x70	5
4	38	GB93-12		washer 12	10
4	39	GB6170-M12		nut M12	5

# Parts Breakdown - Chassis

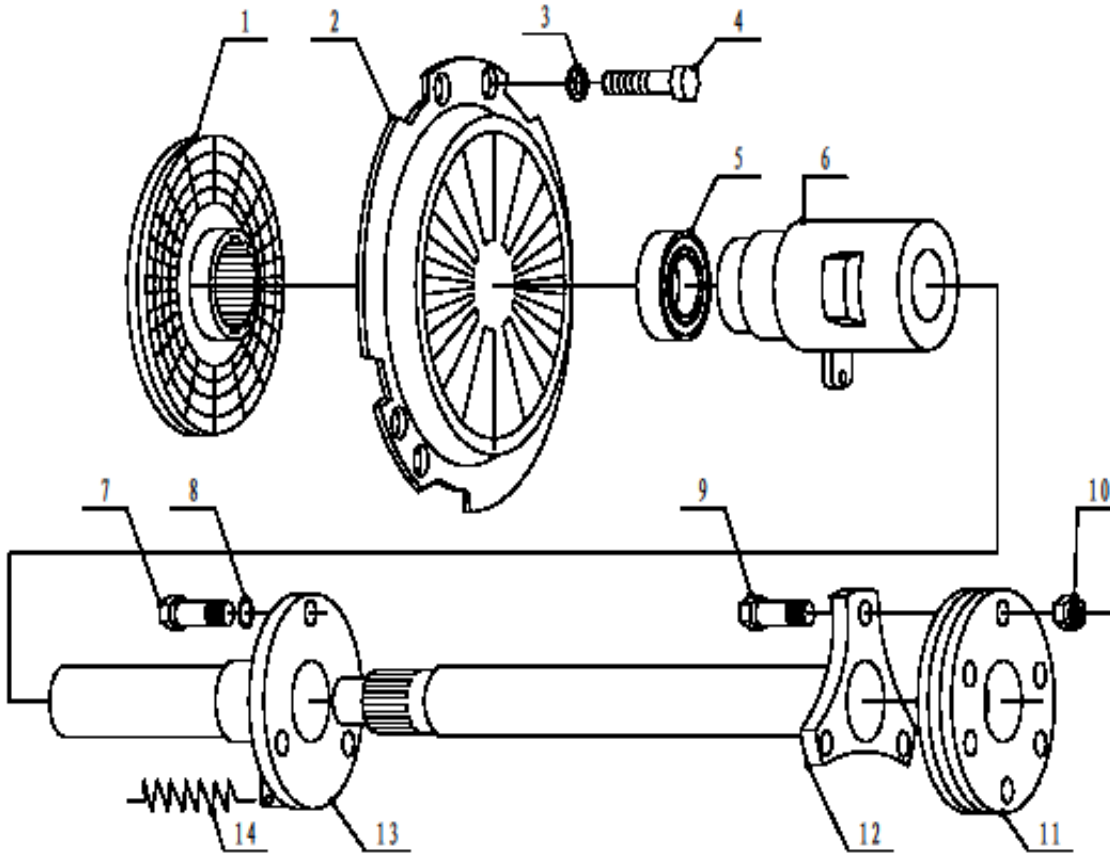
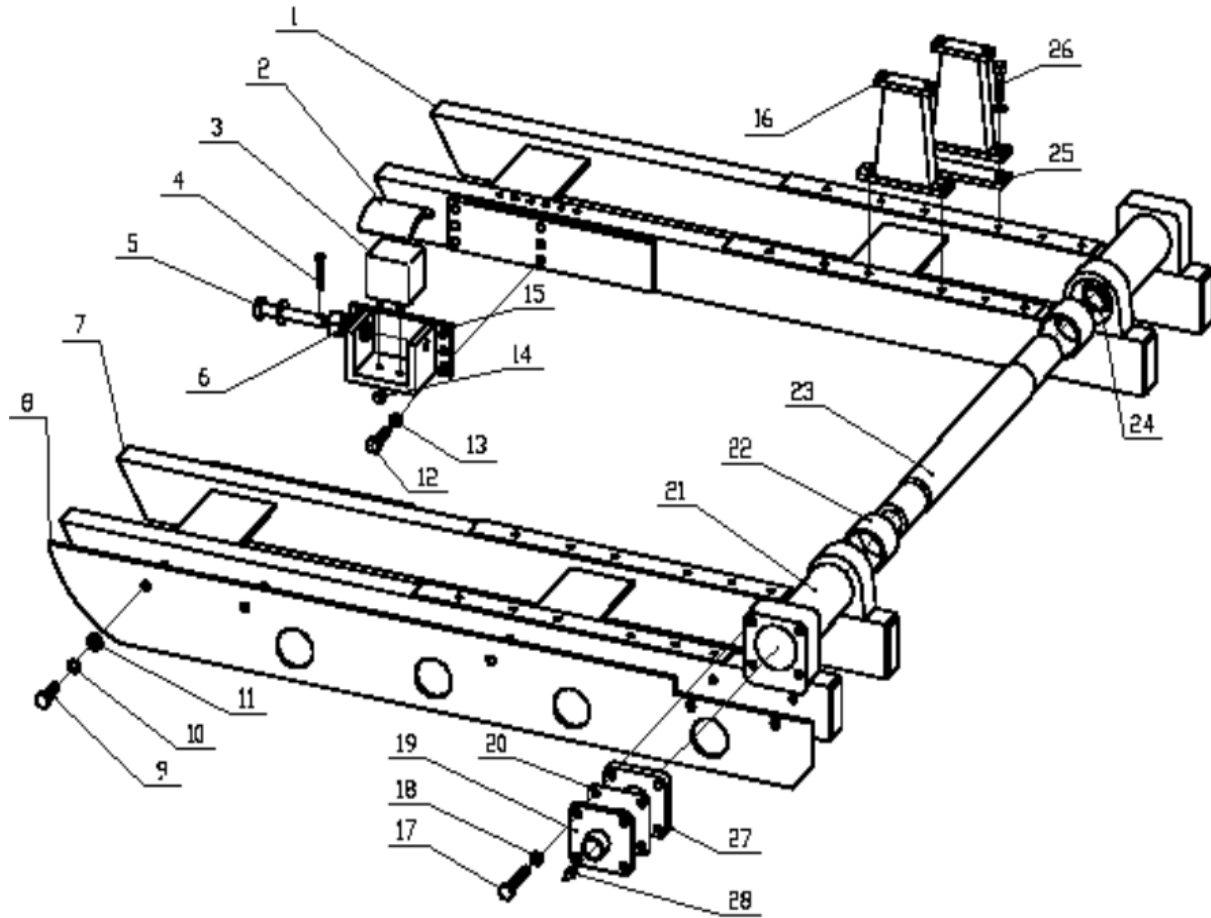

**Fig.5 Clutch housing assembly (II)**

Fig#	Ref#	Mfg Part#	NTE Part#	Description	Qty
5	1	F255-1601200	FCF2551601200	clutch driven disc assembly	1
5	2	F255-1601100	FCF2551601100	clutch pressure disc assembly	1
5	3	GB93-8		washer 8	6
5	4	GB5782-M8x20		Bolt M8x20	6
5	5	688911	FC688911	release bearing	1
5	6	302L-5.21.514	FC302L521514	release bearing seat	1
5	7	GB5782-M8x20		Bolt M8x20	3
5	8	GB93-8		washer 8	3
5	9	GB5782-M8x32		bolt M8x32	3
5	10	GB6179-M10		nut M10	3
5	11	252L.21.056	FC252L21056	coupling assembly	1
5	12	302L-5.21.065	FC302L521065	clutch shaft assembly	1
5	13	302L-5.21.501	FC302L521501	release bearing bracket	1
5	14	252L.21.104	FC252L21104	return spring	1

# Parts Breakdown - Chassis

Fig.6 Undercarriage frame assembly



Fig#	Ref#	Mfg. Part#	NTE Part#	Description	Qty
6	1	302-6.34.063N	FC302634063N	right undercarriage frame weldment	1
6	2	302-6.34.504	FC302634504	rubber buffer glue piece	2
6	3	252L.34.060	FC252L34060	rubber buffer glue piece	2
6	4	GB91-3x25	FCGB91325	cotter pin 3x25	2
6	5	252L.34.505	FC252L34505	bolt	2
6	6	GB6178-M16		Fluted nut M16	2
6	7	302-6.34.062N	FC302634062N	left undercarriage frame weldment	1
6	8	302-6.34.716N		outer guard board	2
6	9	GB5783-M12x30		bolt M12x30	26
6	10	GB93-12		washer 12	26
6	11	GB95-12		washer 12	26
6	12	GB5783-M14x30		bolt M14x30	12
6	13	GB93-14		washer 14	12
6	14	GB6170-M10		nut M10	4
6	15	252L.34.502A	FC252L34502A	support of equalizing beam	2

# Parts Breakdown - Chassis

Fig#	Ref#	Mfg. Part#	NTE Part#	Description	Qty
6	16	302-6.34.070	FC302634070	bracket weldment for carrier roller	8
6	17	GB5783-M16x35		Bolt M16x35	8
6	18	GB93-16		washer 16	8
6	19	302-6.34.071	FC302634071	end cap of swinging shaft	2
6	20	252L.34.508	FC252L34508	paper gasket	2
6	21	252L.34.540	FC252L34540	Swinging shaft support	2
6	22	252L.34.524A	FC252L34524A	bushing	2
6	23	302-6.43.710	FC302643710	Swinging shaft	1
6	24	302-6.34.712	FC302634712	space bushing	2
6	25	330A2-1100007		Pad for bracket wheel stent	4
6	26	GB5783-M12x35		Bolt M12x35	8
6	27	252L.34.503	FC252L34503	threaded bushing	2
6	28	GB1152-M6	FCGB1152M61	Grease cup M6	2

**Fig.7 Swing shaft**

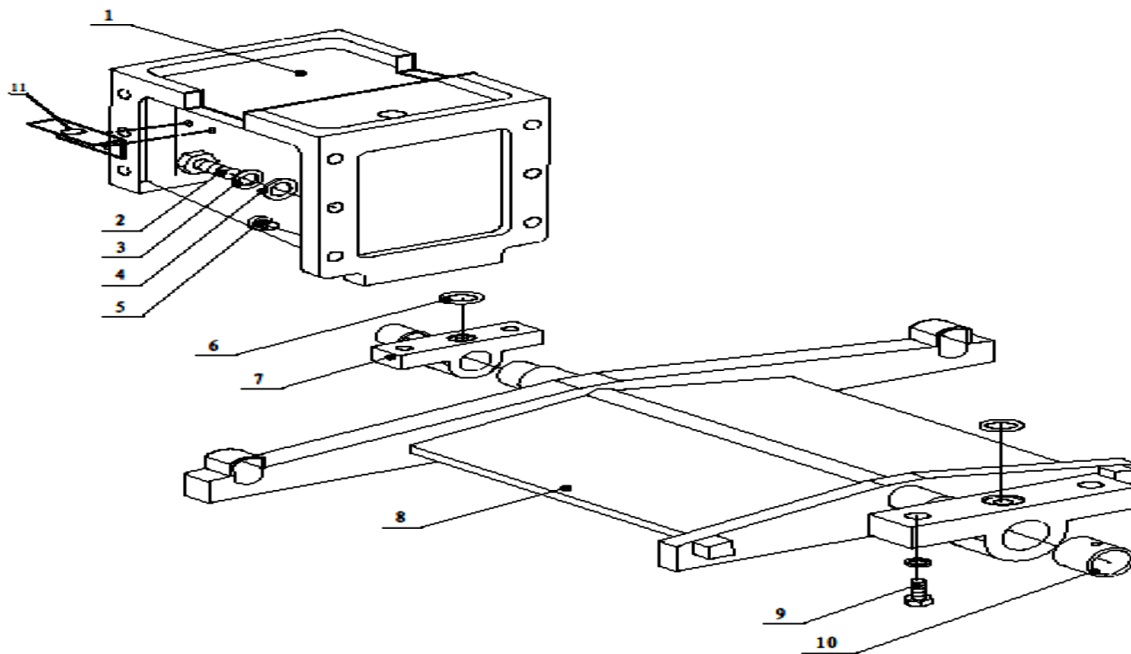

Fig#	Ref#	Mfg. Part#	NTE Part#	Description	Qty
7	1	335A-1100014	FC335A1100014	bracket	1
7	2	GB5782-M16x80	FCGB5782M1680	Bolt M16x80	6
7	3	GB93-16	FCGB9316	washer 16	10
7	4	GB97.1-16	FCGB97116	washer 16	6
7	5	GB1153-M10x1	FCGB1153M101	Oil cup M10x1	2

# Parts Breakdown - Chassis

Fig#	Ref#	Mfg Part#	NTE Part#	Description	Qty
7	6	GB1253		O-ring	2
7	7	302-6.34.088E	FC302634088E	Bracket weldment for swinging shaft	2
7	8	302-6.34.059E	FC302634059E	swinging shaft weldment	1
7	9	GB5782-M16x45	FCGB5782M1645	Bolt M16x45	4
7	10	252L.34.539A	FC252L34539A	Roller bushing	2
7	11	335A-1100051	FC335A1100051	Connect angle iron	2

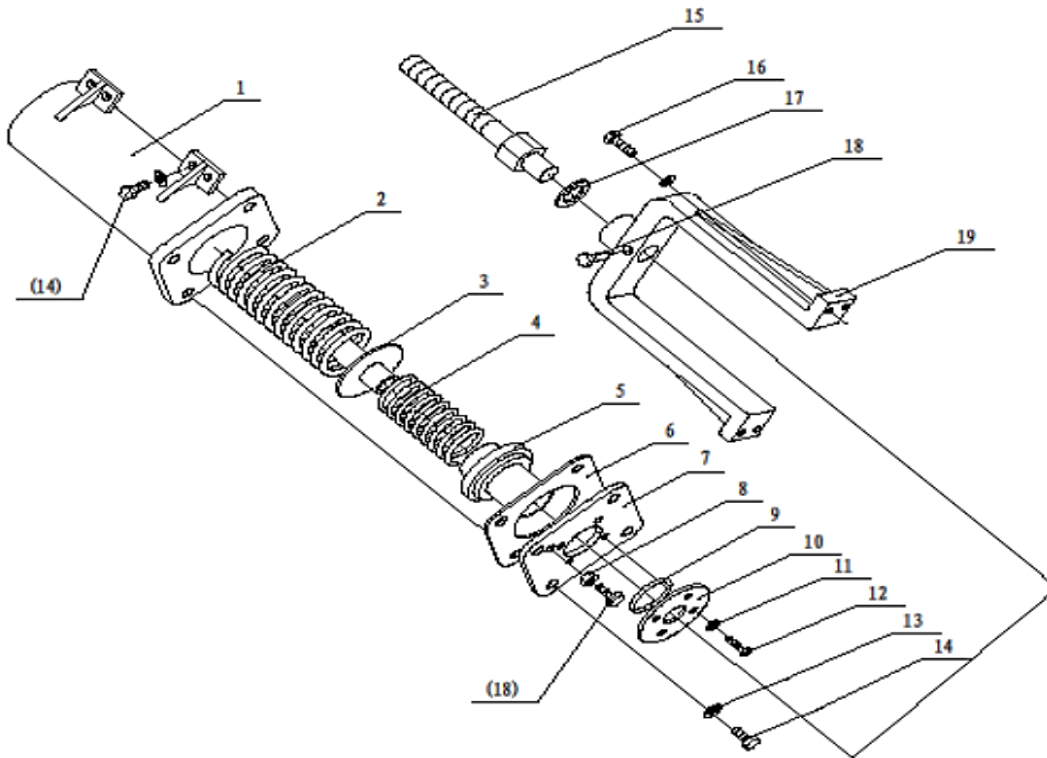

**Fig.8 Track  
Tensioner  
Assembly**

Fig#	Ref#	Mfg Part#	NTE Part#	Description	Qty
8	1	D300.34.064	FCD30034064	barrel weldment for spring	2
8	2	252L.34.528	FC252L34528	big spring	4
8	3	402.34.076	FC40234076	isolating plate	2
8	4	252L.34.529	FC252L34529	small spring	2
8	5	302-6.34.065A	FC302634065A	spring seat	2
8	6	252L.34.531	FC252L34531	paper gasket	2
8	7	Z05.34.527		cover	2
8	8	GB6170-M12		nut M12	2
8	9	FJ145-63		felt seal	2
8	10	252L.34.530A	FC252L34530A	elastic ring	2

# Parts Breakdown - Chassis

Fig#	Ref#	Mfg Part#	NTE Part#	Description	Qty
8	11	GB93-5	FCGB935	washer 5	8
8	12	GB67-M5x10		Button head screw M5x10	8
8	13	GB93-12		washer 12	32
8	14	GB5782-M12x30		Bolt M12x30	24
8	15	D300.34.526	FCD30034526	adjusting bolt	2
8	16	GB5783-M12x50		Bolt M12x50	8
8	17	GB97.1-24		washer 24	8
8	18	GB5783-M12x25	FCGB5783M1225	button head screw M12x25	8
8	19	252L.34.525A	FC252L34525A	hitch yoke	2

**Fig.9 drive sprocket, guiding wheel and track shoe**

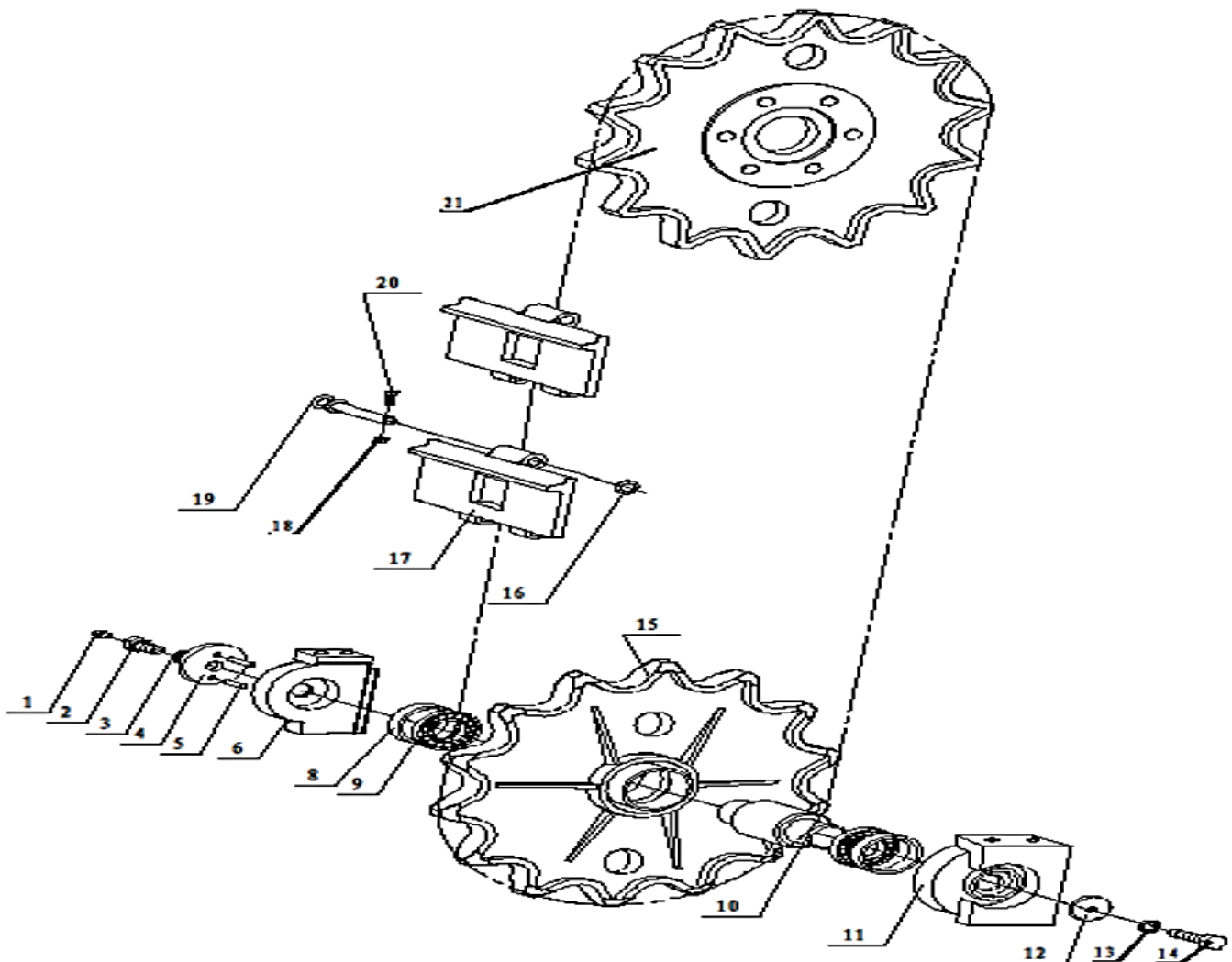

# Parts Breakdown - Chassis

Fig#	Ref#	Mfg Part#	NTE Part#	Description	Qty
9	1	GB1152-M10x1	FCGB1152M101	oil cup M10x1	2
9	2	252L.34.522	FC252L34522	hollow bolt	2
9	3	GB93-16		washer 16	4
9	4	252L.34.521		Thackeray washer	4
9	5	GB119-4dx8	FCGB1194D8	pin 4dx8	4
9	6	252L.34.519	FC252L34519	right guiding wheel's bracket	2
9	8	HG4-692-67-PD60x80x12	FCHG4692PD608012	Oil seal PD60x80x12	4
9	9	GB276-307	FCGB276307	ball bearing 307	4
9	10	252L.34.523	FC252L34523	guiding wheel shaft	2
9	11	252L.34.520	FC252L34520	left guiding wheel's bracket	2
9	12	252L.34.567		Thrust washer	2
9	14	GB5783-M16x30		Bolt M16x30	2
9	15	252L.34.518F	FC252L34518F	guiding wheel	2
9	16	GB95-22	FCGB9522	washer 22	128
9	17	252L.34.510G	FC252L34510G	track shoe	64
9		252L.34.051GL	FC252L37051GL	Left track assembly, complete (Not shown)	
9		252L.34.051GR	FC252L37051GR	Right track assembly, complete (Not shown)	
9	18	GB6184-M8	FCGB6184M8	Nut M8	64
9	19	252L.34.511A	FC252L34511A	track pin	64
9	20	GB5783-M8x30	FCGB5783M830	Bolt M8x30	64
9	21	302-6.34.501N	FC302634501N	drive sprocket	2

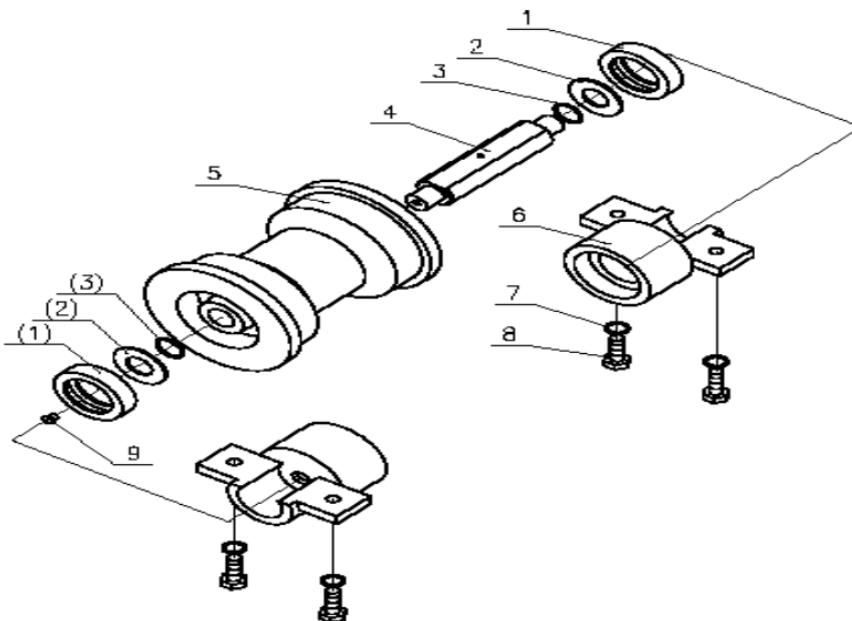
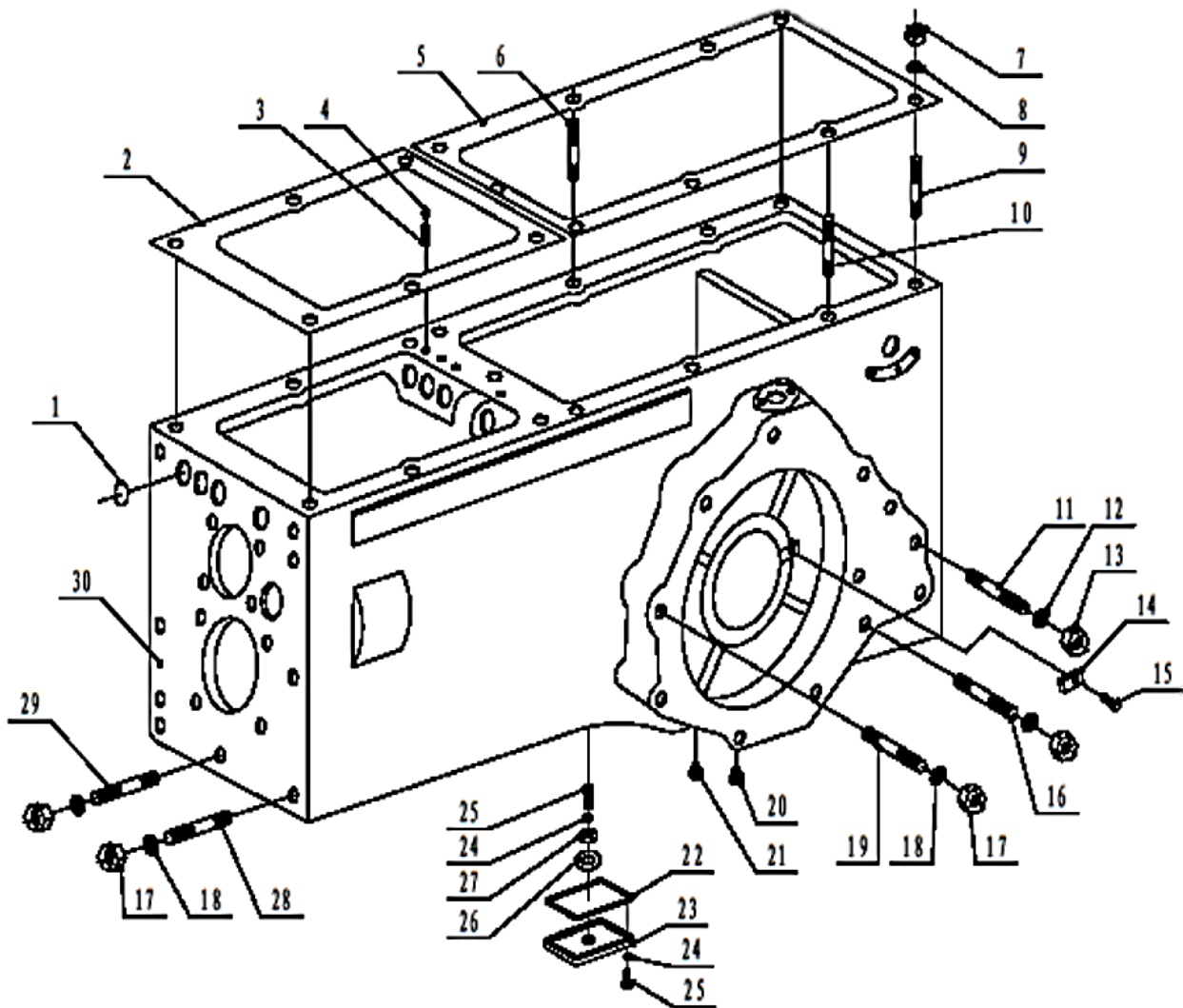

**Fig.10 Track roller assembly**

# Parts Breakdown - Chassis

Fig#	Ref#	Mfg Part#	NTE Part#	Description	Qty
10	1	JB2600-PD70x95x12	FCJB2600PD709512	oil seal PD70x95x12	24
10	2	252L.34.516A	FC252L34516A	Thackeray washer	24
10	3	GB3452.1-D35x3.1	FCGB34521D3531	O-ring D35x3.1	24
10	4	252L.34.514	FC252L34514	track roller shaft	12
10	5	302-6.34.061	FC302634061	track roller assembly	12
10	6	252L.34.515	FC252L34515	bracket for track roller	24
10	7	GB93-12		washer 12	48
10	8	GB5782-M12x30		Bolt M12x30	48
10	9	GB1152-M10x1	FCGB1152M101	grease cup M10x1	12

**Fig.11 Transmission case**



# Parts Breakdown - Chassis

Fig#	Ref#	Mfg Part#	NTE Part#	Description	Qty
11	1	252L.37.600A		plug	4
11	2	252L.37.169	FC252L37169	paper gasket	1
11	3	252L.37.147	FC252L37147	locating spring for fork shaft	4
11	4	GB308-77-11/32"		steel ball 11/32"	4
11	5	252L.37.156A	FC252L37156A	paper gasket for rear cover	1
11	6	GB897-AM12x90		stud AM12x90	5
11	7	GB6170-M12		nut M12	9
11	8	GB93-12		washer 12	9
11	9	GB897-AM12x100		stud AM12x100	2
11	10	GB897-AM12x120		stud AM12x120	2
11	11	GB899-AYM16-M16x1.5x35		Stud AYM16-M16x1.5x35	6
11	12	GB93-16		washer 16	8
11	13	GB6172-M16x1.5		nut M16x1.5	8
11	14	252L.37.175		guiding key	2
11	15	GB68-M6x12		screw M6x12	2
11	16	GB899-AYM16-M16x1.5x45		Stud AYM16-M16x1.5x45	2
11	17	GB6172-M14x1.5		nut M14x1.5	23
11	18	GB93-14		washer 14	23
11	19	GB899-AM14-M14x1.5x30		Stud AM14-M14x1.5x30	16
11	20	137-56-II-K1 cc	FC13756IHK14	screw plug	2
11	21	137-56-II-K1/2	FC13756IHK12	screw plug	1
11	22	252L.37.217	FC252L37217	paper gasket	1
11	23	252L.37.214		cover for permanent magnet	1
11	24	GB93-8		washer 8	5
11	25	GB5782-M8x25		Bolt M8x25	5
11	26	252L.37.215		permanent magnet	1
11	27	252L.37.218	FC252L37218	locking piece for magnet	1
11	28	GB899-AM14-M14x1.5x40		Stud AM14-M14x1.5x40	5
11	29	GB899-AM14-M14x1.5x70		Stud AM14-M14x1.5x70	2
11	30	252L.37.510F	FC252L37510F	Transmission case	1
11		GB5782-M6X16	FCGB5782616	Bolt M6x16 (not shown)	4
11		252L.37.216	FC252L37216	Rubber gasket (not shown)	2
11		252L.37.166	FC252L37166	Limiting piece for adj. nut (not shown)	2
11		252L.37.167	FC252L37167	Locking piece (not shown)	2

# Parts Breakdown - Chassis

Fig.12 Fork & fork shaft

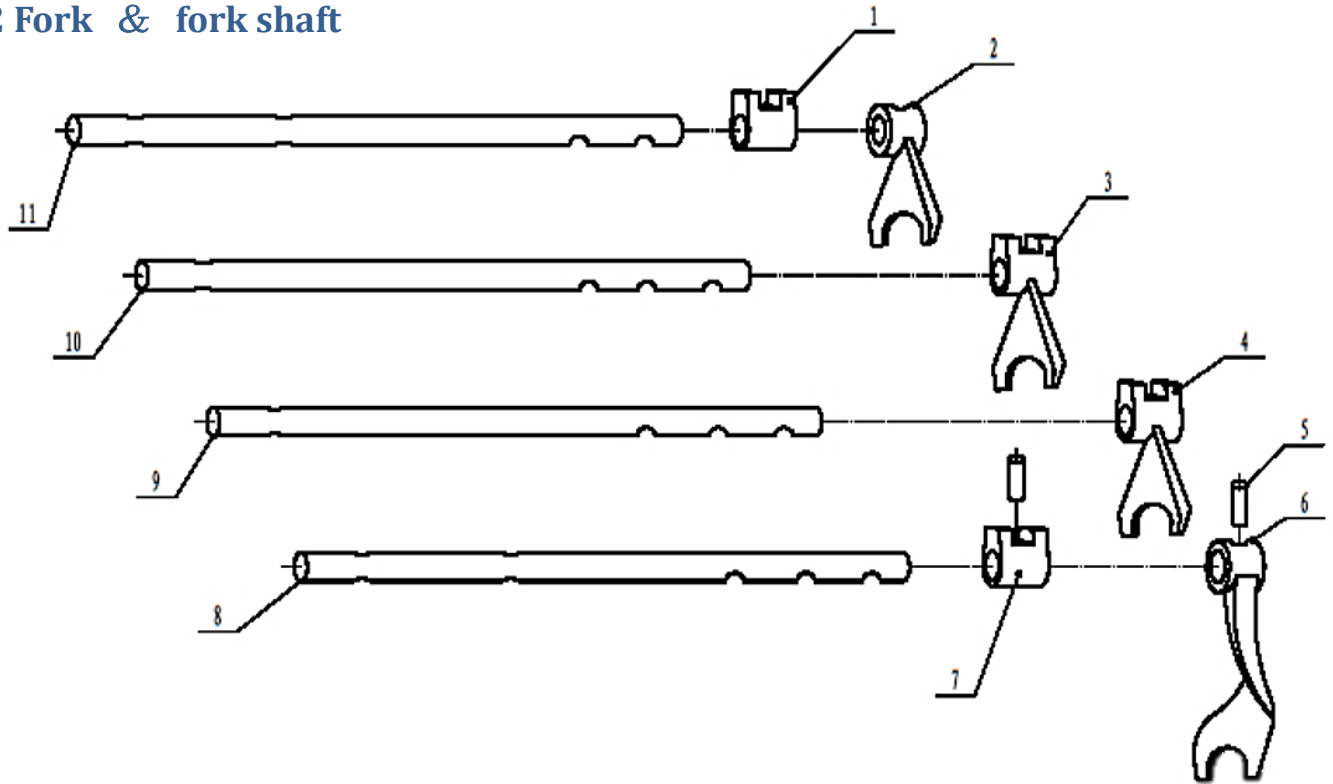

Fig#	Ref#	Mfg Part#	NTE Part#	Description	Qty
12	1	25.37.137	FC2537137	III-IV gearshift fork block	1
12	2	25.37.123	FC2537123	III-IV gear shift fork	1
12	3	25.37.122	FC2537122	II-reverse gear fork	1
12	4	25.37.121	FC2537121	I gear shift fork	1
12	5	GB879-5x25	FCGB879525	elastic pin 5x25	6
12	6	25.37.124	FC2537124	high-low gearshift fork	1
12	7	25.37.138	FC2537138	high-low gearshift fork block	1
12	8	25.37.129	FC2537129	fork shaft for high-low gearshift	1
12	9	25.37.126	FC2537126	shift shaft I	1
12	10	25.37.127	FC2537127	II-reverse gear fork shaft	1
12	11	25.37.128	FC2537128	fork shaft for III-IV	1

# Parts Breakdown - Chassis

Fig.13 PTO control assembly

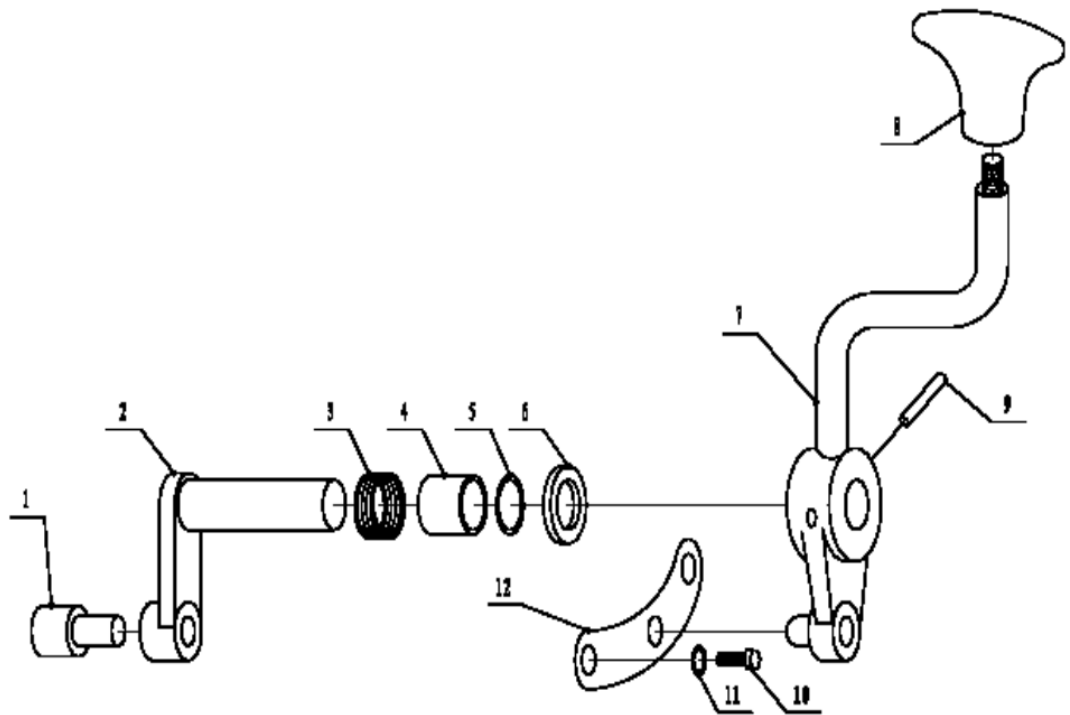

Fig#	Ref#	Mfg. Part#	NTE Part#	Description	Qty
13	1	252L.37.139F	FC252L37139F	sliding block for PTO shaft	1
13	2	252L.37.131A	FC252L37131A	fork shaft for PTO	1
13	3	252L.37.149	FC252L37149	spring for PTO fork shaft	1
13	4	252L.21.115A	FC252L21115A	bushing	1
13	5	GB1235-20x2.4	FCGB12352024	O-ring 20x2.4	1
13	6	GB97.1-16		washer 16	1
13	7	330A3-1204000	FC330A31204000	PTO control lever	1
13	8	302L-6.57.148	FC302L657148	handle	1
13	9	252L.37.200	FC252L37200	locating pin	1
13	10	GB5786-M8x12		bolt M8x12	2
13	11	GB93-8		washer 8	2
13	12	252L.37.165	FC252L37165	locating lever for PTO control lever	1

# Parts Breakdown - Chassis

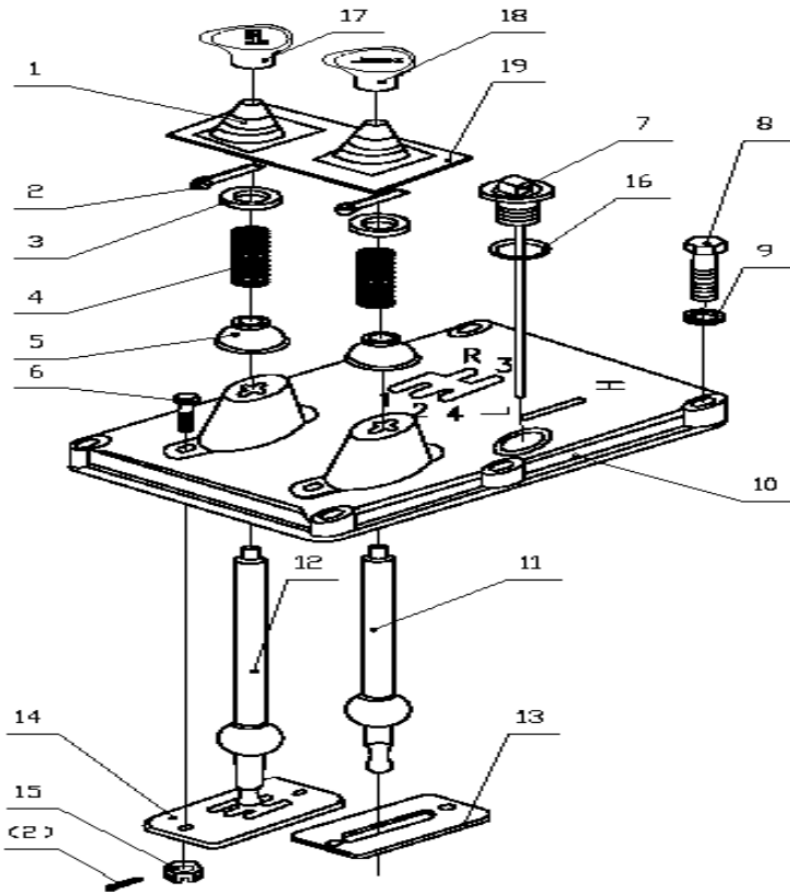
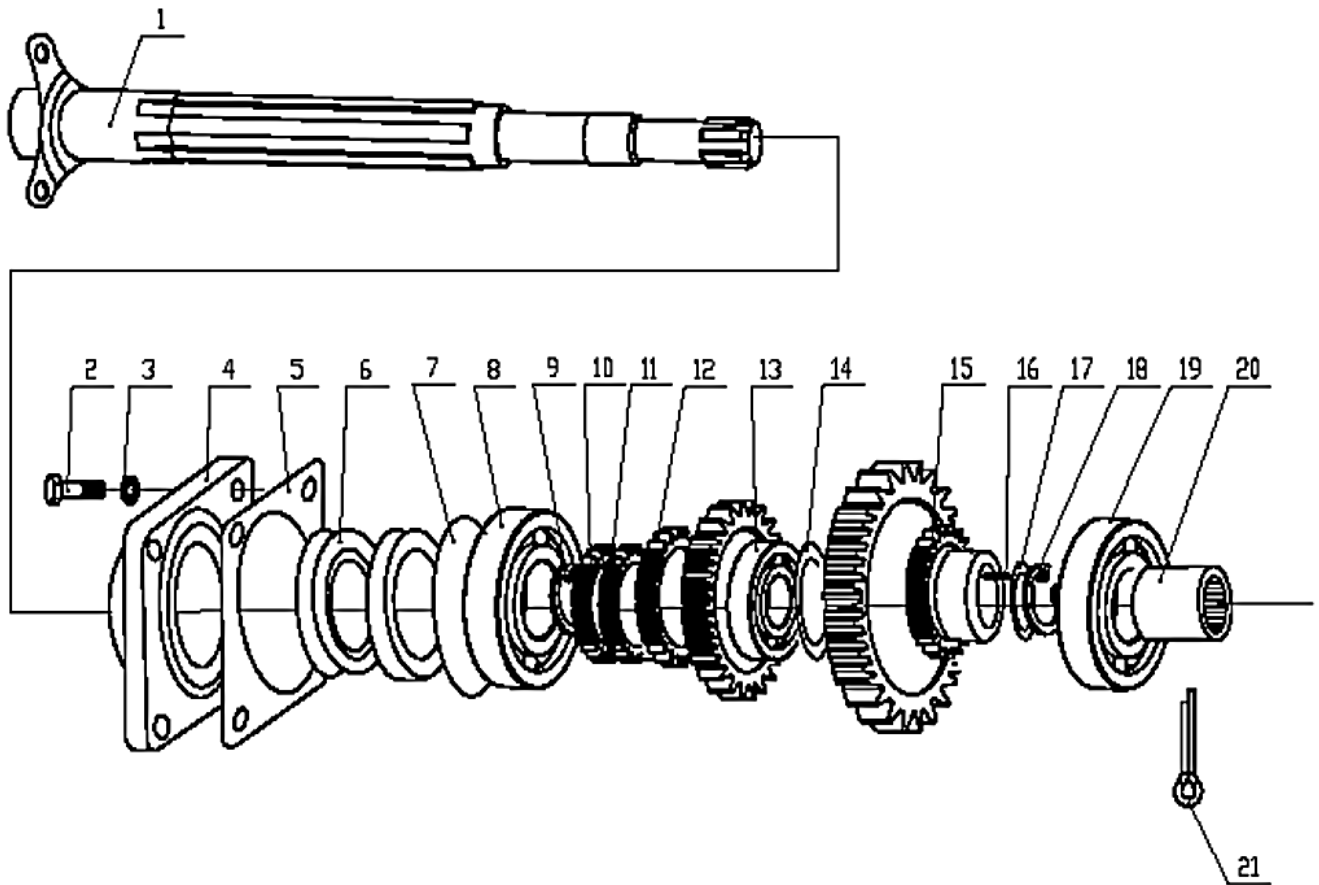

**Fig.14 Transmission case cover assembly**

Fig#	Ref#	Mfg. Part#	NTE Part#	Description	Qty
14	1	302L-5.37.603A	FC302L537603A	protective cover	2
14	2	GB91-2x20	FCGB91220	Cotter pin 2x20	6
14	3	252L.37.195		spring retainer	2
14	4	252L.37.194	FC252L37194	spring	2
14	5	252L.37.196		bowl cover	2
14	6	GB5782-M8x30		Bolt M8x30	4
14	7	252L.37.019A	FC252L37019A	dipstick	1
14	8	GB5782-M8x45		Bolt M8x45	6
14	9	GB93-8		washer 8	6
14	10	252L.37.189F	FC252L37189F	top front cover transmission case	1
14	11	252L.37.193A	FC252L37193A	auxiliary shift lever	1
14	12	252L.37.192A	FC252L37192A	main shift lever	1
14	13	252L.37.191A	FC252L37191A	limit board for auxiliary shift	1
14	14	252L.37.512F	FC252L37512F	limit board for main shift	1
14	15	GB6172-BM8		nut BM8	4
14	16	252L.37.197	FC252L37197	dipstick gasket	1
14	17	302L-5.37.213	FC302L537213	knob of main shift lever	1
14	18	302L-5.37.212	FC302L537212	knob of auxiliary shift lever	1
14	19	330A3-2601010A		cover	1

# Parts Breakdown - Chassis

Fig.15 transmission case shift (I)



Fig#	Ref#	Mfg. Part#	NTE Part#	Description	Qty
15	1	25.37.013B	FC2537013B	shaft I assembly	1
15	2	GB5782-M10x25		Bolt M10x25	12
15	3	GB93-10		washer 10	12
15	4	252L.37.119A		front bearing cover of Shaft I	1
15	5	252L.37.157	FC252L37157	adjusting shims for Shaft I	A/R
15	5	252L.37.158	FC252L37158	adjusting shims for Shaft I	A/R
15	5	252L.37.59	FC252L37159	adjusting shims for Shaft I	A/R
15	6	HG4-692-67-35x56x12	FCHG469267355612	oil seal 35x56x12	1
15	7	252L.37.171	FC252L37171	paper gasket for front cover of Shaft I	1
15	8	GB276-307	FCGB276307	ball bearing 307	1
15	9	GB894-35	FCGB89435	elastic ring 35	1
15	10	25.37.104	FC2537104	Sliding gear I	1
15	11	25.37.106	FC2537106	Sliding gear R-II	1
15	12	25.37.108	FC2537108	Sliding gear III-IV	1
15	13	GB276-106	FCGB276106	ball bearing 106	1

# Parts Breakdown - Chassis

Fig#	Ref#	Mfg. Part#	NTE Part#	Description	Qty
15	14	252L.37.178		isolating ring	1
15	15	25.37.111	FC2537111	high-low speed twin gears	1
15	16	GB309-2.5x16	FCGB3092516	needle roller 2.5x16	90
15	17	252L.37.174		isolating ring	1
15	18	GB893-30	FCGB89330	elastic ring 30	1
15	19	GB277-208	FCGB277208	ball bearing 208	1
15	20	252L.37.136F	FC252L37136F	spline bushing	1
15	21	GB91-5x45	FCGB91545	Cotter pin 5x45	1

**Fig.16 Transmission case Shaft II**

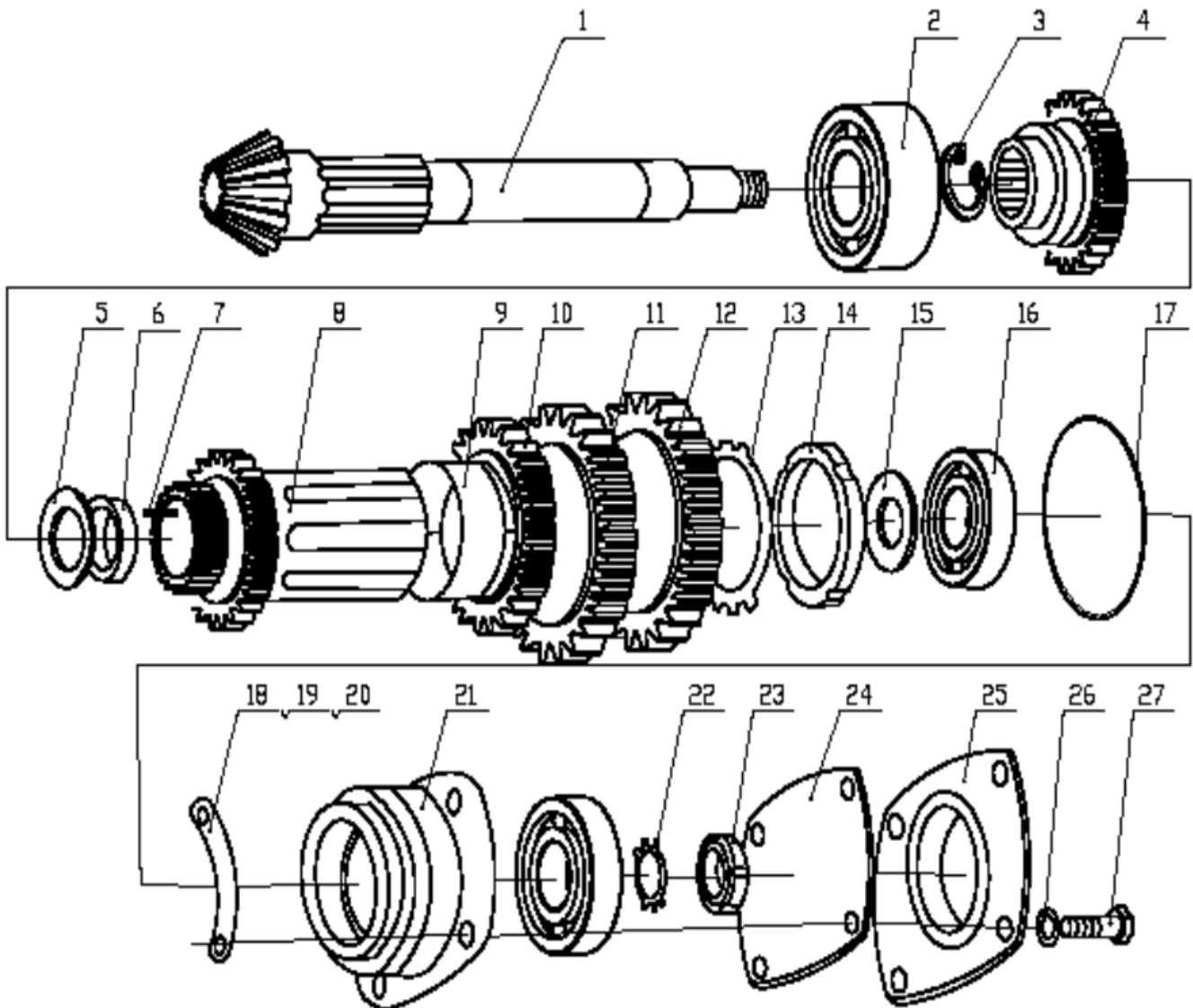

## Parts Breakdown - Chassis

Fig#	Ref#	Mfg. Part#	NTE Part#	Description	Qty
16	1	25.37.101Q		shaft II	1
16	2	GB286-3608	FCGB2863608	ball bearing 3608	1
16	3	GB894-40	FCGB89440	elastic ring 40	1
16	4	25.37.112	FC2537112	high-low shift sliding gear	1
16	5	252L.37.152	FC252L37152	rear thackeray washer for shaft II	1
16	6	252L.37.144	FC252L37144	blocker ring of needle bearing for shaft II	1
16	7	GB309-3x24	FCGB309324	needle roller 3x24	72
16	8	25.37.110	FC2537110	spline bushing of shaft II	1
16	9	25.37.142	FC2537142	blocker ring of shaft II	1
16	10	25.37.109	FC2537109	shift III driven gear	1
16	11	25.37.107	FC2537107	shift II driven gear	1
16	12	25.37.105	FC2537105	shift I driven gear	1
16	13	GB858-60	FCGB85860	lock washer 60	1
16	14	GB810-M60x2		round nut M60x2	1
16	15	252L.37.151		front thackeray washer for shaft II	2
16	16	GB298-27305	FCGB29827305	ball bearing 27305	2
16	17	GB1235-90x5.7	FCGB12359057	O -ring 90x5.7	1
16	18	252L.37.132	FC252L37132	adjusting shims for shaft II	A/R
16	19	252L.37.133	FC252L37133	adjusting shims for shaft II	A/R
16	20	252L.37.134	FC252L37134	adjusting shims for shaft II	A/R
16	21	252L.37.117	FC252L37117	front bushing for Shaft II	1
16	22	GB858-24	FCGB85824	lock washer 24	1
16	23	GB812-M24x1.5		Round nut M24x1.5	1
16	24	252L.37.170	FC252L37170	paper gasket	1
16	25	252L.37.135A		front bearing cover of shaft II	1
16	26	GB93-10		washer 10	4
16	27	GB5782-M10x25		Bolt M10x25	4

# Parts Breakdown - Chassis

Fig.17 PTO shaft

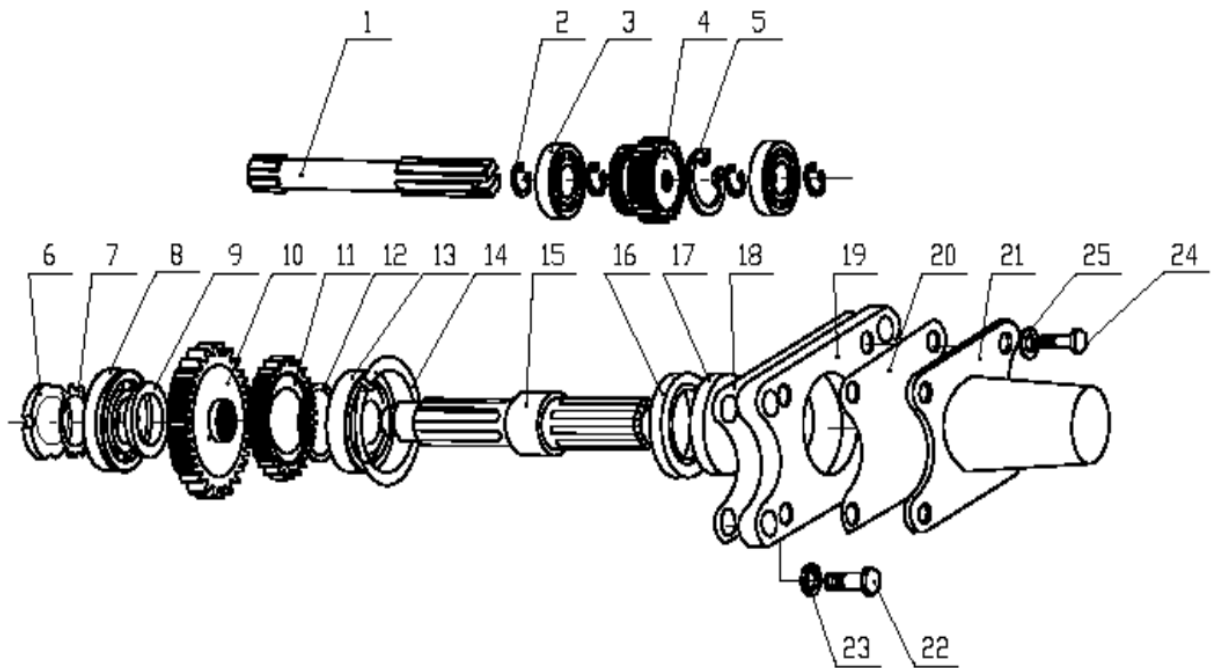

Fig#	Ref#	Mfg. Part#	NTE Part#	Description	Qty
17	1	252L.37.102F	FC252L37102F	drive shaft	1
17	2	GB894-25	FCGB89425	elastic ring 25	4
17	3	GB276-205	FCGB276205	ball bearing 205	2
17	4	25.37.114	FC2537114	sliding gear	1
17	5	GB893-52	FCGB89352	elastic ring 52	1
17	6	GB812-M24x1.5		Round nut M24x1.5	1
17	7	GB858-24	FCGB85824	lock washer 24	1
17	8	GB276-305	FCGB276305	ball bearing 305	1
17	9	302-6.37.151	(use FC252L37151)	Front thackeray washer for shaft II	2
17	9	252L.37.151	FC252L37151	Front thackeray washer for shaft II	2
17	10	302-6.37.116	(use FC2537116)	PTO low speed gear	1
17	10	25.37.116	FC2537116	PTO low speed gear	1
17	12	302-6.37.155	(use FC252L37155)	PTO rear thackeray washer	1
17	12	252L.37.155	FC252L37155	PTO rear thackeray washer	1
17	13	GB277-50207	FCGB27750207	ball bearing 50207	1
17	14	GB305-72	FCGB30572	thrust ring 72	1
17	15	302-6.37.682	(use FC252L37103A)	PTO shaft	1
17	15	252L.37.103A	FC252L37103A	PTO shaft	1
17	16	HG4-692-67-45x65x12	FCHG469267456512	Oil seal 45x65x12	1
17	17	302-6.37.690	(use FC252L37021)	Bushing	1

## Parts Breakdown - Chassis

Fig#	Ref#	Mfg. Part#	NTE Part#	Description	Qty
17	17	252L.37.021	FC252L37021	Bushing	1
17	18	252L.37.172	FC252L37172	paper gasket for rear cover	1
17	19	252L.37.118A	FC252L37118A	rear cover for PTO shaft	1
17	20	302-6.37.691	(use FC252L37173)	Baffle	1
17	20	252L.37.173	FC252L37173	Baffle	1
17	21	252L.37.146	FC252L37146	protective cover for PTO	1
17	22	GB5782-M12x40		Bolt M12x40	4
17	23	GB93-12		washer 12	4
17	24	GB5783-M10x30		bolt M10x30	4

**Fig.18 Reverse shaft assembly**

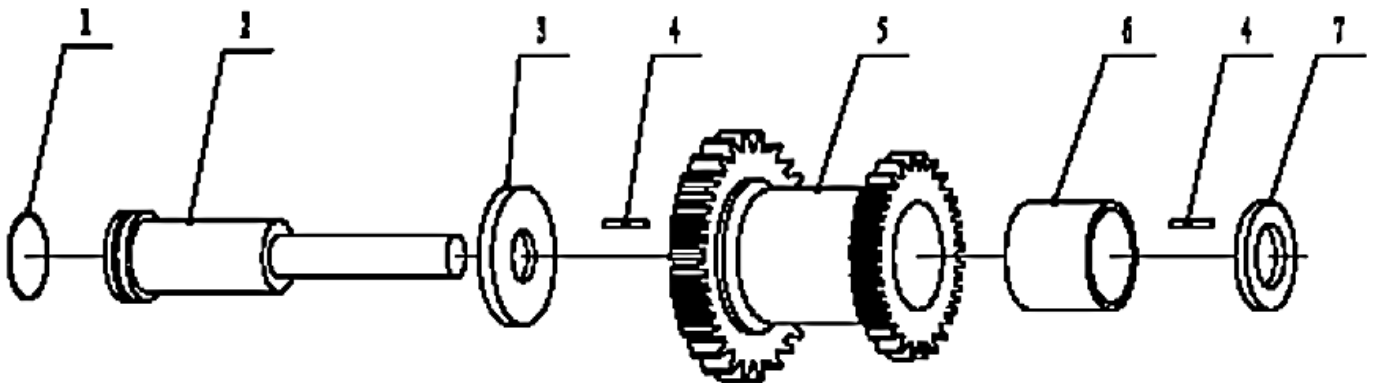

Fig#	Ref#	Mfg. Part#	NTE Part#	Description	Qty
18	1	GB1235-32x3.5	FCGB12353235	O-ring 32x3.5	1
18	2	25.37.120	FC2537120	reverse shaft	1
18	3	252L.37.153	FC252L37153	front thrust ring for reverse shaft	1
18	4	GB309-2.5x16	FCGB3092516	needle roller 2.5x16	90
18	5	25.37.113	FC2537113	reverse gear	1
18	6	252L.37.145	FC252L37145	retainer shell	1
18	7	252L.37.154	FC252L37154	behind thrust ring for reverse shaft	1

# Parts Breakdown - Chassis

**Fig.19 Central transmission**

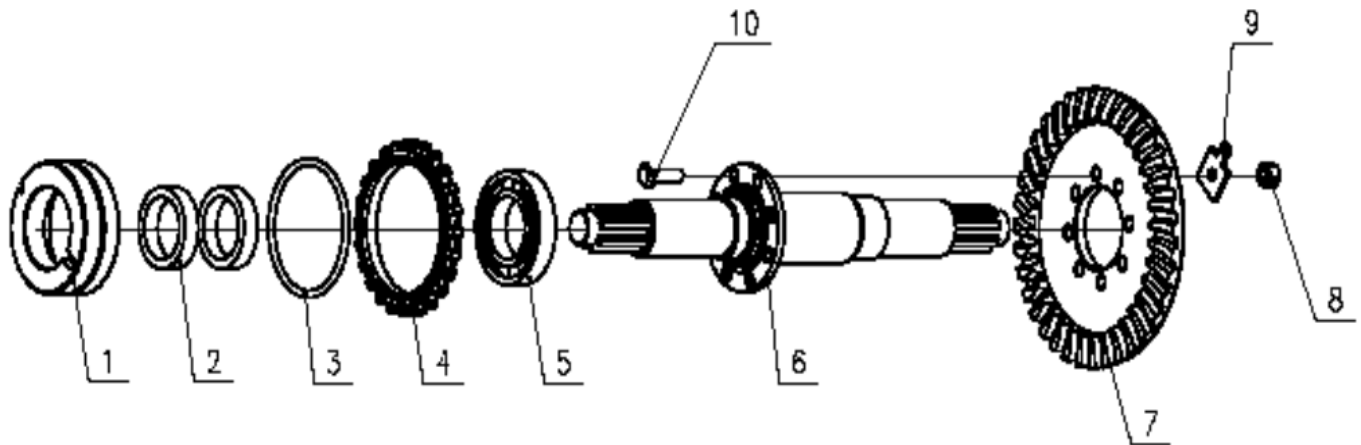

Fig#	Ref#	Mfg. Part#	NTE Part#	Description	Qty
19	1	252L.37.505	FC252L37505	bearing seat for central transmission	2
19	2	HG4-692-67-45x65x1 2	FCHG46926745651 2	Oil seal 45x65x12	4
19	3	GB1235-105x5.7	FCGB123510557	o-ring 105x5.7	2
19	4	252L.37.150	FC252L37150	adjusting nut for differential	2
19	5	GB297-7210	FCGB2977210	ball bearing 7210	2
19	6	252L.37.507	FC252L37507	central drive shaft	1
19	7	252L.37.506Q		big bevel gear	1
19	8	GB6170-M10		nut M10	8
19	9	252L.37.509		lock washer	4
19	10	252L.37.187A		bolt for bevel gear	8
19		GB5782-M6X16	FCGB5782616	Bolt M6x16 (Not shown)	4
19		252L.37.216	FC252L37216	Rubber gasket (Not shown)	2
19		252L.37.166	FC252L37166	Limiting piece for adj. nut (Not shown)	2
19		252L.37.167	FC252L37167	Locking piece (Not shown)	2

# Parts Breakdown - Chassis

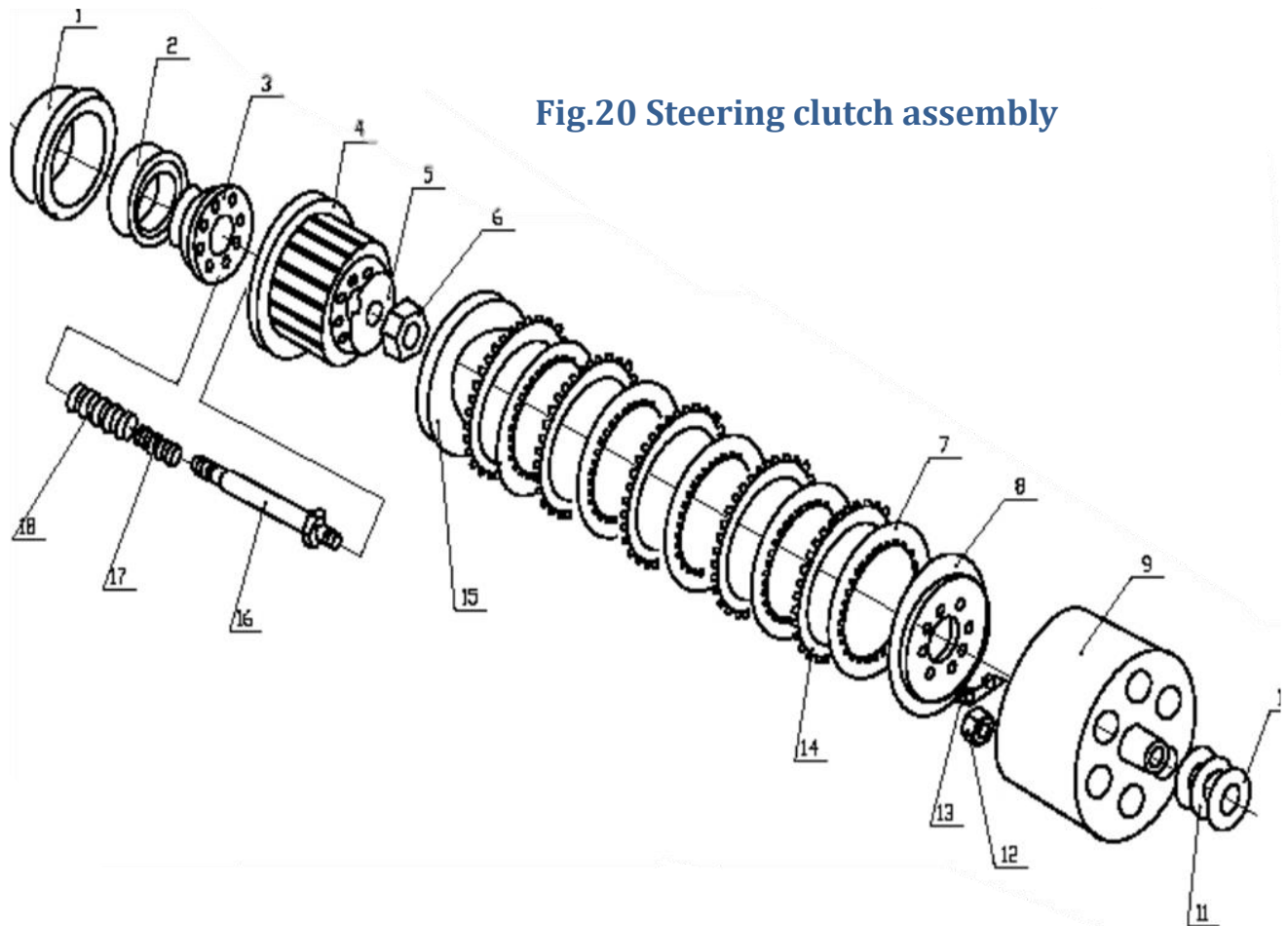
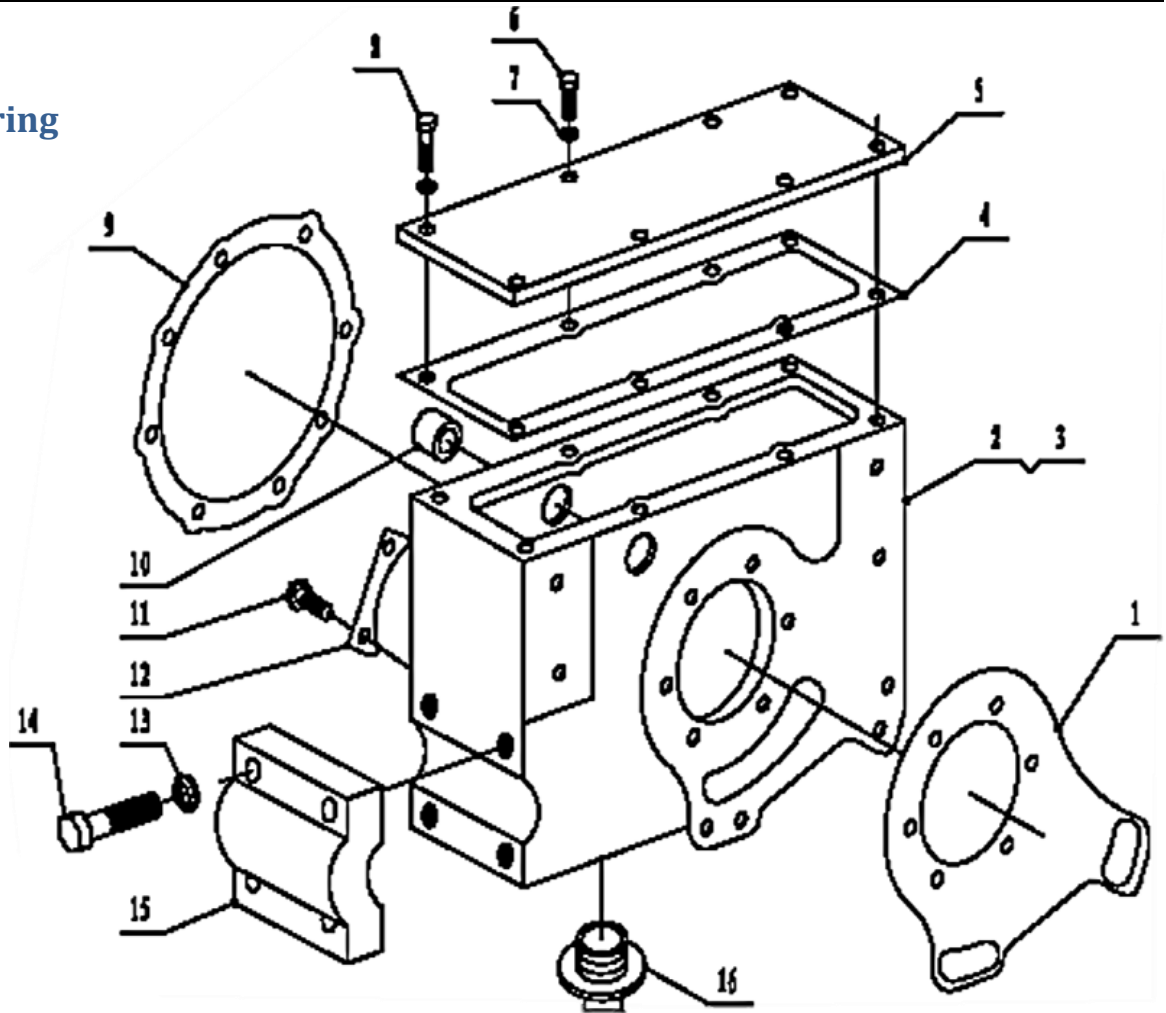

**Fig.20 Steering clutch assembly**

Fig#	Ref#	Mfg. Part#	NTE Part#	Description	Qty
20	1	252L.39.535	FC252L39535	release bearing seat	2
20	2	GB278-80211	FCGB27880211	ball bearing 80211	2
20	3	302-6.39.559	FC302639559	clutch release pressure plate	2
20	4	302-6.39.558	FC302639558	steering clutch drive drum	2
20	5	GB856-27	FCGB85627	lock washer 27	2
20	6	GB6173-M27x1.5		nut M27x1.5	2
20	7	302-6.39.556	FC302639556	steering clutch driving plate	14
20	8	302-6.39.560	FC302639560	steering clutch pressure plate	2
20	9	252L.39.501B	FC252L39501B	steering clutch driven hub	2
20	10	JB2600-PD55x75x12	FCJB2600PD557512	oil seal PD55x75x12	4
20	11	252L.39.519	FC252L39519	reparatory gasket	2
20	12	GB6172-M10		nut M10	20
20	13	302-6.39.561		locking piece	10
20	14	302-6.39.555	FC302639555	friction plate	12
20	15	302-6.39.557		washer	1
20	16	252L.39.533	FC252L39533	guiding bolt	20
20	17	252L.39.531	FC252L39531	small spring	20
20	18	252L.39.530	FC252L39530	big spring	20

# Parts Breakdown - Chassis

Fig.21 Steering  
clutch  
housing  
assembly



Fig#	Ref#	Mfg. Part#	NTE Part#	Description	Qty
21	1	252L.39.508	FC252L39508	paper gasket	2
21	2	302-6.39.525	FC302639525	left steering clutch housing	1
21	3	302-6.39.526	FC302639526	right steering clutch housing	1
21	4	252L.39.524	FC252L39524	paper gasket	2
21	5	252L.39.523	FC252L39523	Cover of steering clutch case	2
21	6	GB5782-M10x20		Bolt M10x20	12
21	7	GB93-10		washer 10	16
21	8	GB5782-M10x30		Bolt M10x30	4
21	9	252L.39.505	FC252L39505	gasket	2
21	10	252L.39.541A	FC252L39541A	bushing	4
21	11	GB5782-M14x35		bolt M14x35	12
21	12	252L.39.517A		locking piece	6
21	13	GB93-16		washer 16	8
21	14	GB5782-M16x60		Bolt M16x60	8
21	15	Z05.39.518		cover for swing shaft	2
21	16	137-59-II-1/2"	FC13756IIK12	screw plug II-1/2"	2

# Parts Breakdown - Chassis

**Fig.22 Final drive housing assembly**

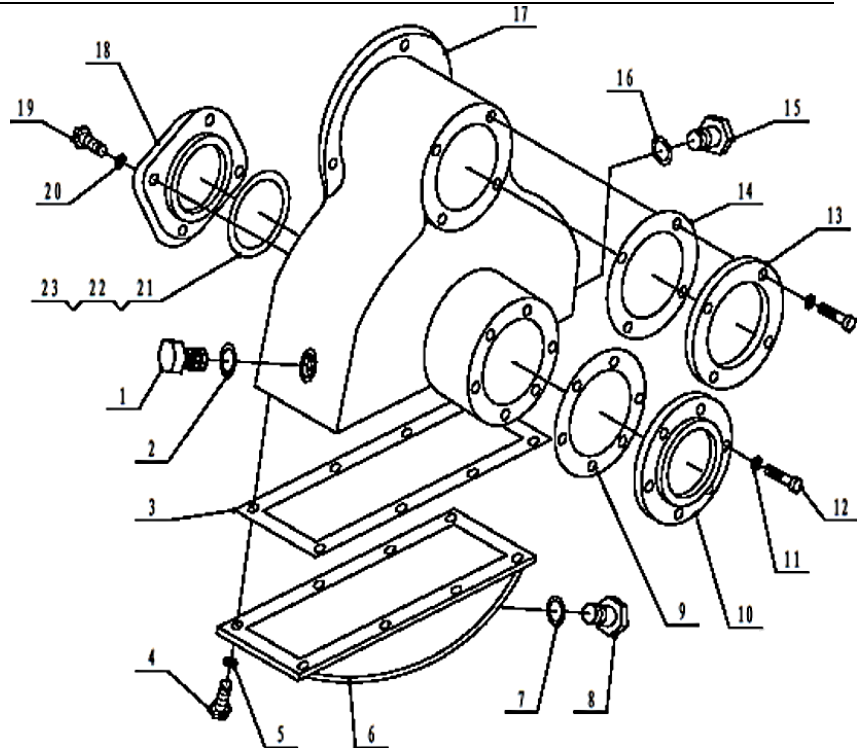

Fig#	Ref#	Mfg. Part#	NTE Part#	Description	Qty
22	1	252L.39.521	FC252L39521	oil drain plug	2
22	2	JB982-27	FCJB98227	seal washer 27	2
22	3	252L.39.516	FC252L39516	paper gasket	1
22	4	GB5782-M8x20		Bolt M8x20	8
22	5	GB93-8		washer 8	8
22	6	252L.39.515A	FC252L39515A	cover of final drive case	2
22	7	JB982-14	FCJB98214	seal washer 14	2
22	8	252L.58.518	FC252L58518	oil drain plug	2
22	9	252L.39.119	FC252L39119	outer gasket	2
22	10	252L.39.513		bearing cap	2
22	11	GB93-10		washer 10	20
22	12	GB5782-M10x25		Bolt M10x25	20
22	13	252L.39.510	FC252L39510	semi-axle bearing cap	2
22	14	252L.39.120	FC252L39120	paper gasket	2
22	15	252L.39.521	FC252L39521	oil drain plug	2
22	16	JB982-27	FCJB98227	seal washer 27	2
22	17	252L.39.502B	FC252L39502B	final transmission housing	2
22	18	252L.39.514A		inner bearing cap	2
22	19	GB5782-M12x25		Bolt M12x25	8
22	20	GB93-12		washer 12	8
22	21	252L.39.700	FC252L39700	adjusting shim	A/R
22	22	252L.39.701	FC252L39701	adjusting shim	A/R
22	23	252L.39.702	FC252L39702	adjusting shim	A/R

# Parts Breakdown - Chassis

**Fig.23 Final drive**

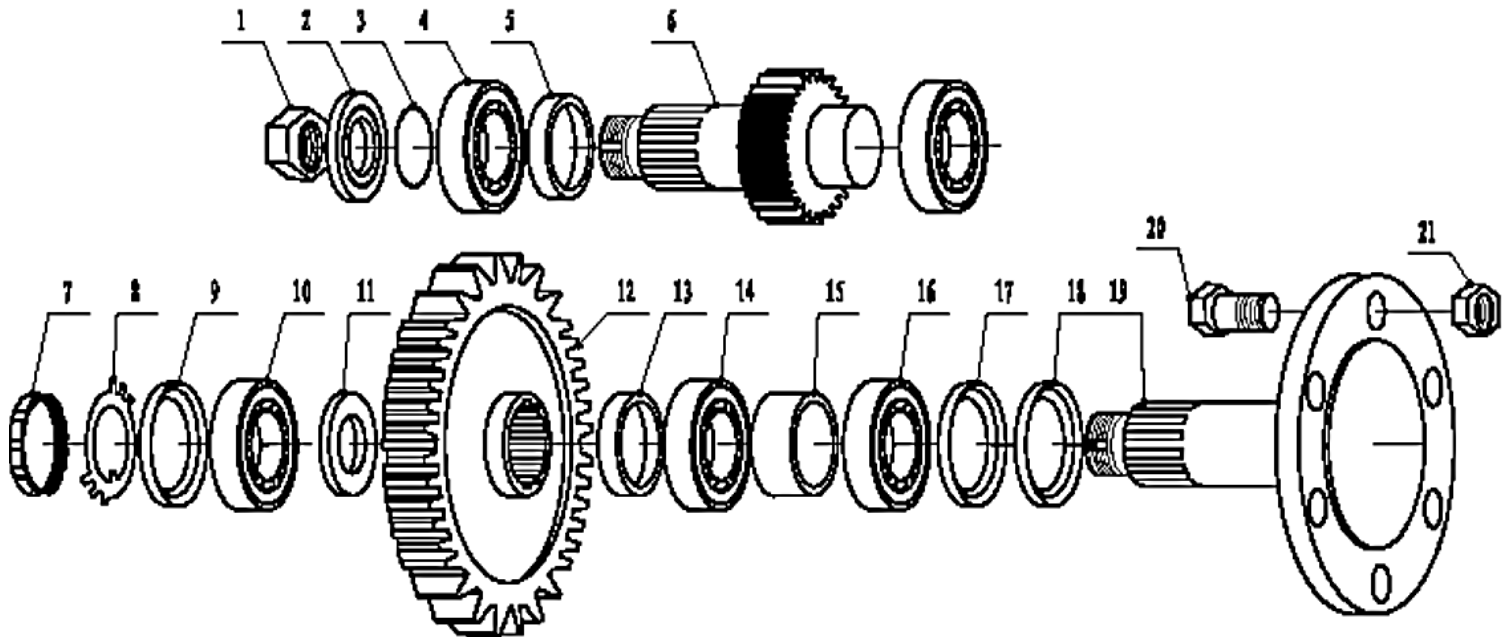

Fig#	Ref#	Mfg. Part#	NTE Part#	Description	Qty
23	1	252L.39.806E	FC252L39806E	Compression nut	2
23	2	252L.39.506D	FC252L39506D	Compression washer	2
23	3	GB3452.1-31x3.5	FCGB345213135	O-ring 31x3.5	2
23	4	GB276-209	FCGB276209	bearing 209	4
23	5	252L.39.509	FC252L39509	elastic ring for semi-axle	2
23	6	252L.39.503D (R)	FC252L39503D	semi-axle gear	2
23	7	GB812-M33x1.5		round nut M33x1.5	2
23	8	GB858-33	FCGB85833	locking washer 33	2
23	9	252L.39.104	FC252L39104	washer	2
23	10	GB297-7307	FCGB2977307	roller bearing 7307	2
23	11	252L.39.512	FC252L39512	tapered washer	2
23	12	252L.39.504A (Q)	FC252L39504A	final big drive gear	2
23	13	Z05.39.551	FCZ0539551	short sleeve	2
23	14	GB276-212	FCGB276212	bearing 212	2
23	15	Z05.39.550	FCZ0539550	long sleeve	2
23	16	GB297-7212	FCGB2977212	roller bearing 7212	2
23	17	JB2600-70x95x12	FCJB2600709512	seal 70x95x12	2
23	18	252L.39.014	FC252L39014	felt seal	2
23	19	Z05.39.537	FCZ0539537	drive shaft	2
23	20	252L.39.538	FC252L39538	sprocket fixing bolt	12
23	21	252L.39.114	FC252L39114	sprocket fixing nut	12

# Parts Breakdown - Chassis

**Fig.24 Steering clutch control assembly**

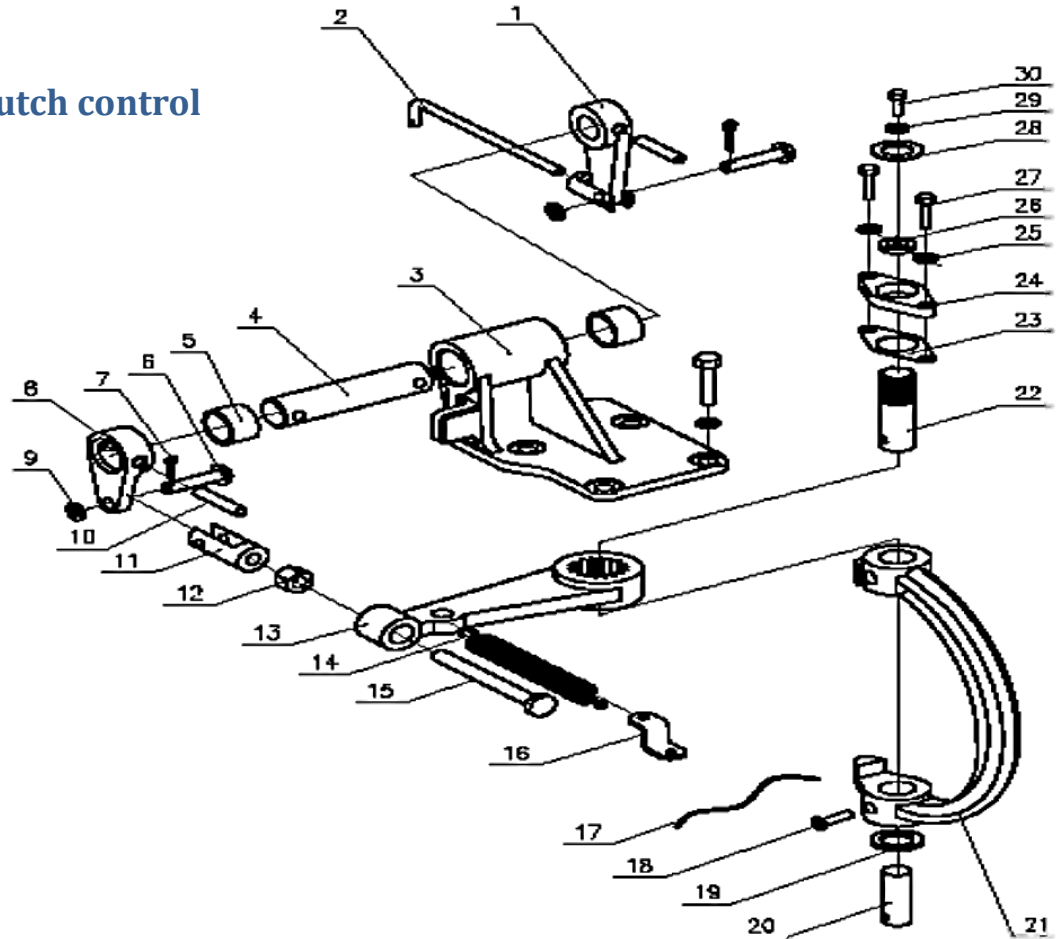

Fig#	Ref#	Mfg. Part#	NTE Part#	Description	Qty
24	1	252L.40.056		linkage lever weldment	2
24	2	252L-4.40.105A	FC252L440105A	drawing bar	2
24	3	252L-4.40.010	FC252L440010	left steering bracket assembly	1
24	3	252L-4.40.011	FC252L440011	right steering bracket assembly	1
24	4	252L.40.514	FC252L40514	universal driving shaft	1
24	5	252L-4.40.102	FC252L440102	Bushing	2
24	6	GB882-B8x30	FCGB882B830	pin 8x30	4
24	7	GB91-3x20	FCGB91320	Cotter pin 3x20	2
24	8	252L.40.513	FC252L40513	rocker	4
24	9	GB97.1-8-140HV		washer 8-140HV	2
24	10	GB879-8x45	FCGB879845	Elastic pin 8x45	2
24	11	252L.43.109	FC252L43109	adjusting fork for drawing bar	4
24	12	GB6172-M10		nut M10	2
24	13	252L.40.501	FC252L40501	fork rocker	2
24	14	252L.40.508	FC252L40508	tension spring	2
24	15	252L.40.053	FC252L40053	drawing bar weldment	2
24	16	252L.40.512	FC252L40512	leaf spring	2
24	17	GB344-64-1-10		steel wire $\Phi$ 1-10	L=500mm

## Parts Breakdown - Chassis

---

Fig#	Ref#	Mfg. Part#	NTE Part#	Description	Qty
24	18	252L.40.502	FC252L40502	locating screw	4
24	19	252L.40.507	FC252L40507	washer	2
24	20	252L.40.504	FC252L40504	lower fork shaft	2
24	21	252L.40.503	FC252L40503	release fork	2
24	22	252L.40.505	FC252L40505	upper fork shaft	2
24	23	252L.40.511	FC252L40511	paper gasket	2
24	24	252L.40.509	FC252L40509	seal	2
24	25	GB93-8		washer 8	4
24	26	252L.40.510	FC252L40510	felt seal	2
24	27	GB5782-M8x25		Bolt M8x25	4
24	28	252L.40.506		washer	2
24	29	GB93-16		washer 16	2
24	30	GB5782-M16x25		bolt M16x25	2

# Parts Breakdown - Chassis

Fig.25 Brake assembly (I)

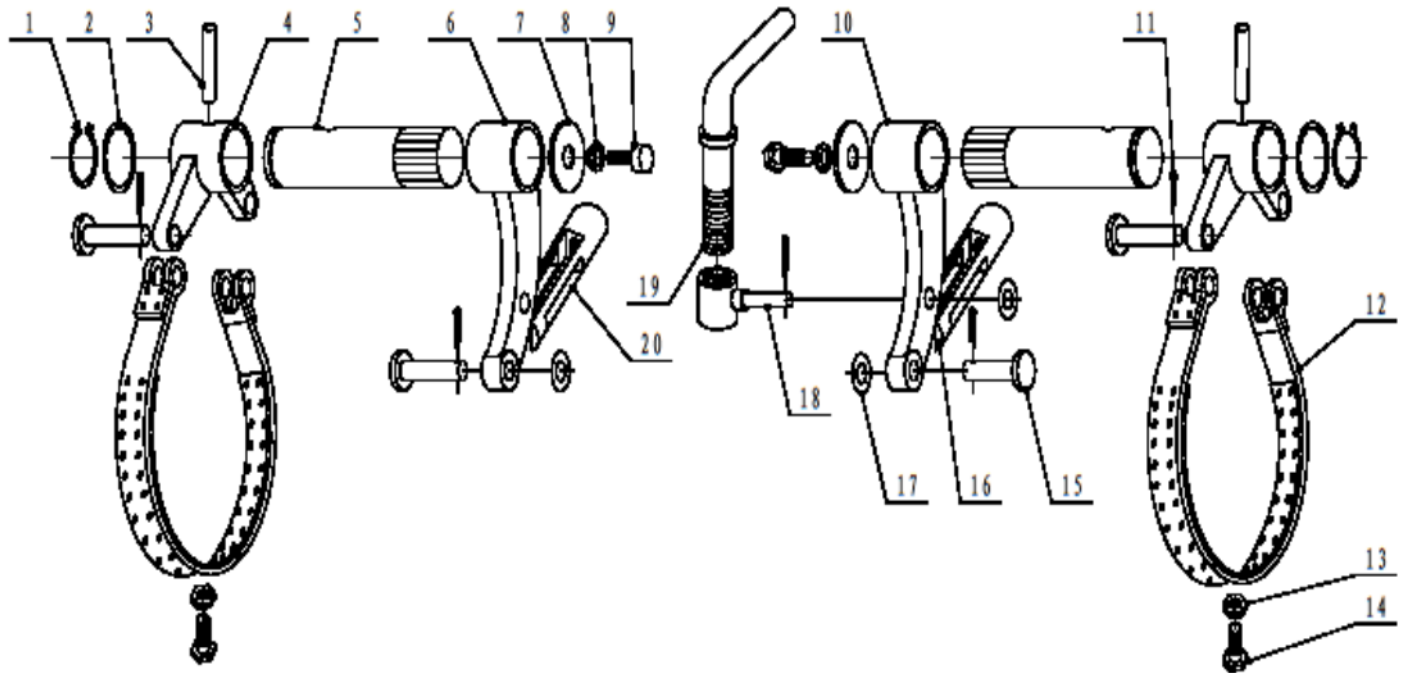

Fig#	Ref#	Mfg. Part#	NTE Part#	Description	Qty
25	1	GB894-25	FCGB89425	elastic washer 25	2
25	2	252L.43.121		thackeray washer	2
25	3	GB879-8x45	FCGB879845	Elastic pin 8x45	2
25	4	252L.43.502	FC252L43502	brake cam	2
25	5	252L.43.503	FC252L43503	brake shaft	2
25	6	252L.43.504	FC252L43504	left brake arm	1
25	7	252L.43.137		washer	2
25	8	GB93-8		washer 8	4
25	9	GB5782-M8x45		Bolt M8x45	2
25	10	252L.43.505A	FC252L43505A	right brake arm	1
25	11	GB91-3x20	FCGB91320	Cotter pin 3x20	5
25	12	252L.43.051	FC252L43051	brake band assembly	2
25	13	GB6170-M10		nut M10	2
25	14	GB5782-M10x35		Bolt M10x35	2
25	15	GB882-B8x30	FCGB882B830	pin B8x30	4
25	16	252L-4.43.104	FC252L443104	adjusting fork (right)	1
25	17	GB97.1-8		washer 8	5
25	18	252L-4.43.022	FC252L443022	nut	1
25	19	252L-4.43.021	FC252L443021	Adjusting threaded rod	1
25	20	252L-4.43.118	FC252L443118	adjusting rod (left)	1

# Parts Breakdown - Chassis

Fig.26 Brake assembly (II)

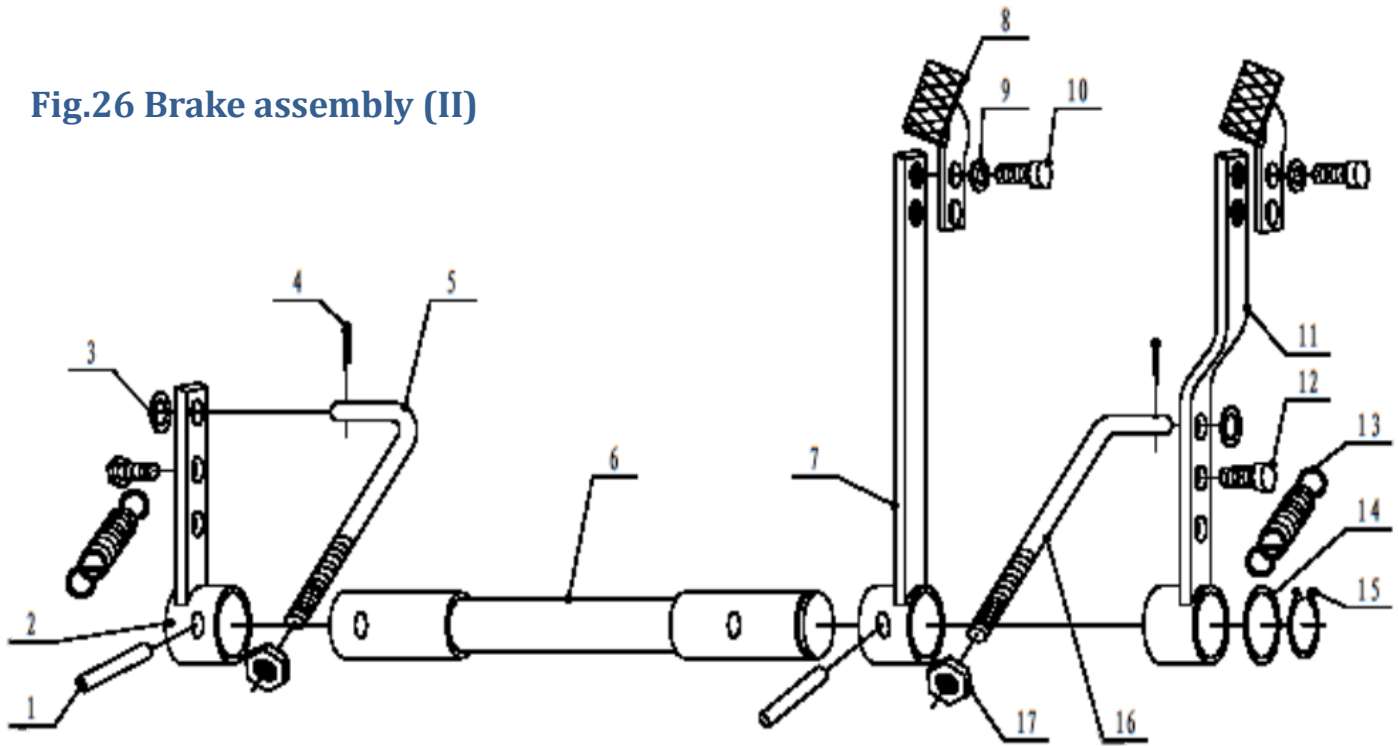

Fig#	Ref#	Mfg. Part#	NTE Part#	Description	Qty
26	1	GB879-8x45	FCGB879845	Elastic pin 8x45	2
26	2	252L-4.43.018A	FC252L443018A	rocker arm weldment	1
26	3	GB93-10		washer 10	2
26	4	GB91-3x20	FCGB91320	Cotter pin 3x20	2
26	5	330A3-1500002	FC330A31500002	brake drawing rod	1
26	6	252L-4.43.102	FC252L443102	pedal shaft	1
26	7	330A3-1503000	FC330A31503000	left brake pedal assembly	1
26	8	330A3-1501000A	FC330A31501000A	right steering pedal	2
26	9	GB93-8		washer 8	4
26	10	GB5782-M8x20		Bolt M8x20	4
26	11	330A3-1504000A	FC330A31504000A	right brake pedal assembly	1
26	12	GB5782-M8x16	FCGB5782816	bolt M8x20	2
26	13	252L.21.110	FC252L21110	Pedal return spring	2
26	14	252L.43.121		thackeray washer	2
26	15	GB894-25	FCGB89425	elastic washer 25	2
26	16	252L-4.43.120A	FC252L443120A	brake drawing rod	1
26	17	GB6170-M10		nut M10	2

# Parts Breakdown - Chassis

Fig.27 Operator's seat

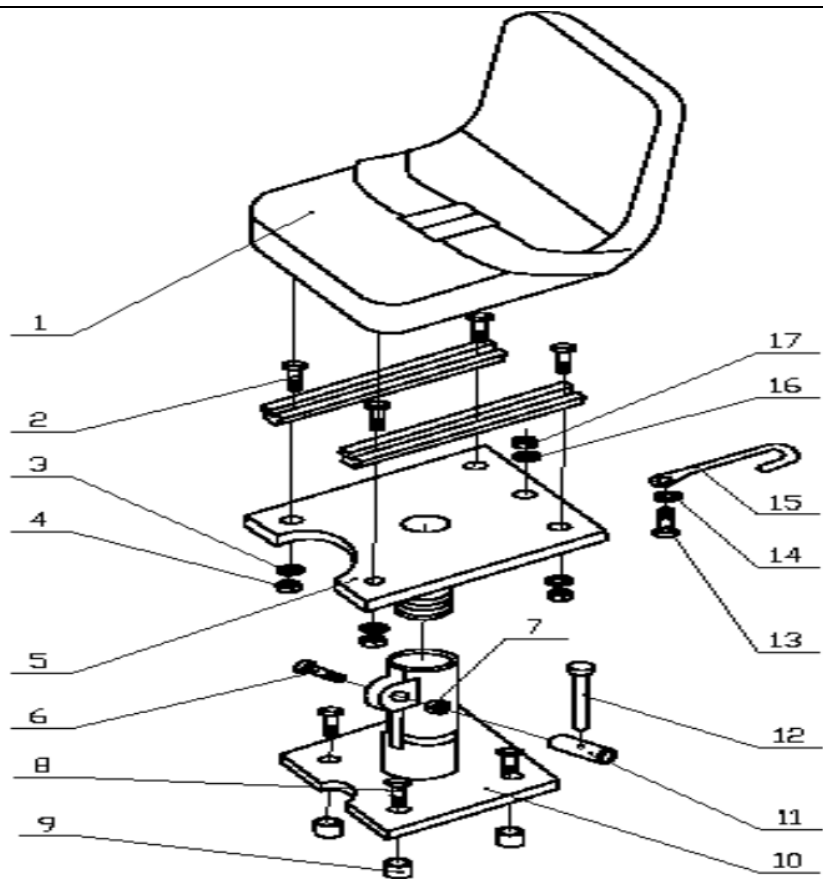

Fig#	Ref#	Mfg. Part#	NTE Part#	Description	Qty
27	1	S44	FCS44	seat assembly	1
27	1	SC2-13	FCSC213	Seat assembly	1
27	2	GB5782-M8x16	FCGB5782816	bolt M8x16	4
27	3	GB6170-M8	FCGB6170M8	nut M8	4
27	4	GB93-8		washer 8	4
27	5	252L-4.44.011A		screw weldment	1
27	6	GB5782-M12x40		Bolt M12x40	5
27	7	GB6170-M12		nut M12	1
27	8	GB5780-M12x40		bolt M12x40	4
27	9	252L-4.44.103		block	4
27	10	252L-4.44.012		pedestal weldment	1
27	11	252L-4.44.102		nut	11
27	12	252L-4.44.101		handle	1
27	13	302-5.44.505		bolt	1
27	14	GB93-6		washer 6	1
27	15	302-5.44.013		hook weldment	1
27	16	GB97.1-6		washer 6	1
27	17	GB6170-M6		nut 6	1
27	18			busing	1

# Parts Breakdown - Chassis

**Fig.28 Canopy assembly**

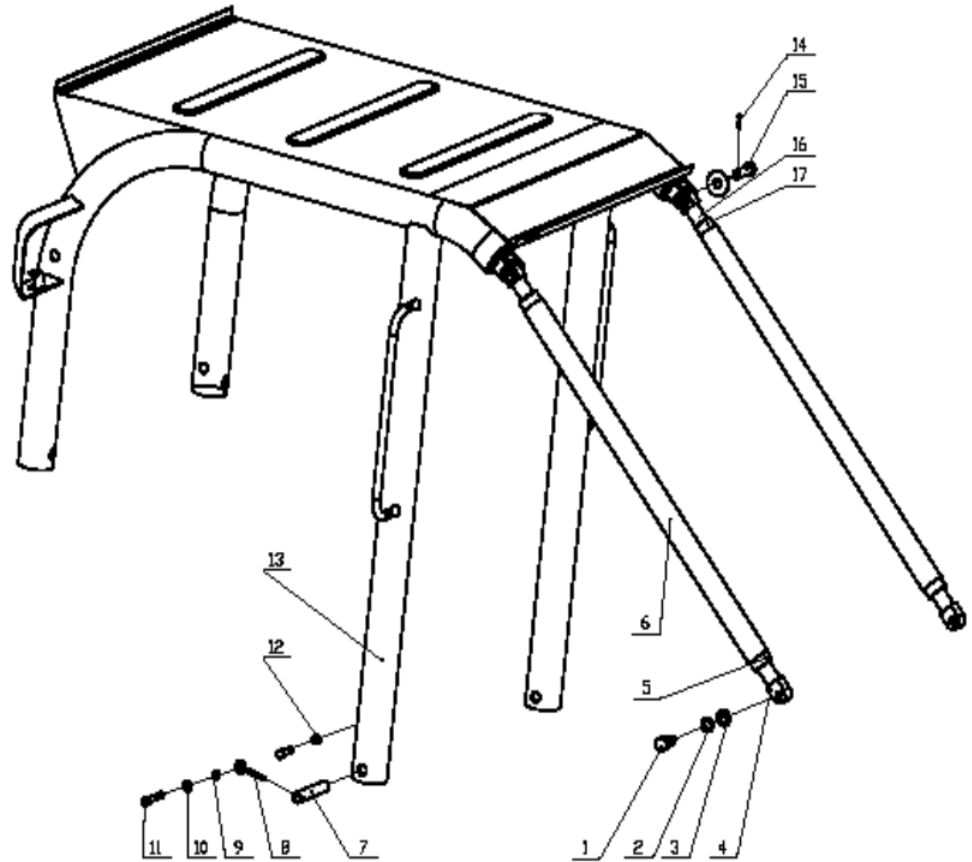

Fig#	Ref#	Mfg. Part#	NTE Part#	Description	Qty
28	1	GB5783-M20x45		bolt M20x45	2
28	2	GB93-20		washer 20	2
28	3	GB97-20		washer 20	4
28	4	302-6H.45.123		adjusting screw (left handed)	2
28	5	GB810-M36x1.5-LH		round nut M36x1.5 (left handed)	2
28	6	302-6H.45.070A	FC3026H45070A	guard bar weldment	2
28	7	302L-5.45.701	FC302L545701	pin	4
28	8	402L.75.125		battle pin	4
28	9	GB97-12		washer 12	10
28	10	GB93-12		washer 12	10
28	11	GB5783-M12x45	FCGB5783M1245	bolt M12x45	12
28	12	GB6170-M12		nut M12	8
28	13	302-6H.45.050A		canopy weldment	1
28	14	GB91-5x30	FCGB91530	Cotter pin 5x30	2
28	15	GB882-B20x70	FCGB882B2070	pin shaft B20x70	2
28	16	302-6H.45.124		adjusting screw (right handed)	2
28	17	GB810-M36x1.5-RH		round nut M36x1.5 (right handed)	2

# Parts Breakdown - Chassis

Fig.29 Engine  
hood  
assembly

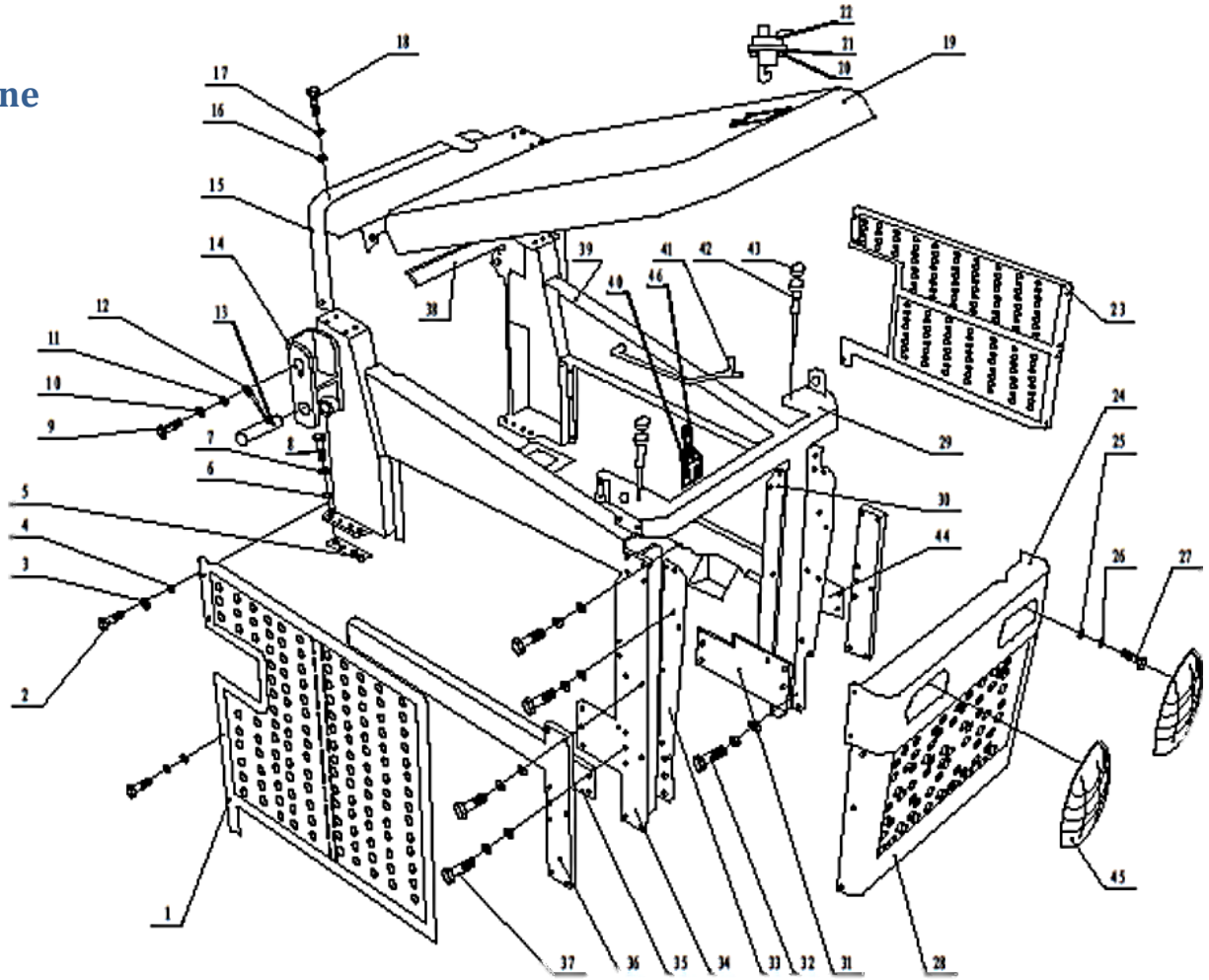

Fig#	Ref#	Mfg. Part#	NTE Part#	Description	Qty
29	1	335A-2212000		right side board weldment	1
29	2	GB5782-M8x20		Bolt M8x20	28
29	3	GB93-8		washer 8	28
29	4	GB97.1-8		washer 8	28
29	5	302-6.47.208		plate	A/R
29	6	GB97.1-10		washer 10	28
29	7	GB93-10		washer 10	28
29	8	GB5782-M10x55		Bolt M10x55	4
29	9	GB5782-M12x25		Bolt M12x25	2
29	10	GB93-12		washer 12	2
29	11	GB97.1-12		washer 12	2
29	12	LW01-3		battle pin	2
29	13	302-6.75.239	FC302675239	pin shaft	2
29	14	335A-2204000		right bracket weldment	1
29	15	302-6.47.039D		rear girder weldment	1

# Parts Breakdown - Chassis

Fig#	Ref#	Mfg. Part#	NTE Part#	Description	Qty
29	16	GB97.1-16		washer 16	18
29	17	GB93-16		washer 16	18
29	18	GB5782-M16x40		bolt M16x40	4
29	19	302-6.47.045D	FC302647045D	hood assembly	1
29	20	GB/T65-M5x15		bolt M5x15	3
29	21	GB93-5	FCGB935	washer 5	1
29	22	302-6.47.801	FC302647801	lock	1
29	23	302-6.47.080B		left side board weldment (1)	1
29	24	302-6.47.037	FC302647037	light bracket weldment	1
29	25	GB97.1-4		washer 4	6
29	26	GB93-4		washer 4	6
29	27	GB5782-M4x30		bolt M4x30	6
29	28	302-6.47.301A		front hole board	1
29	29	302-6.47.038A	FC302647038A	front girder weldment	1
29	30	302-6.47.307A		transition connecting board	2
29	31	335A-2207000		left stay bar weldment	1
29	32	GB5782-M16x50		bolt M16x50	10
29	33	302-6.47.306A		transition connecting board(1)	2
29	34	302-6.47.036A		right stay bar weldment	1
29	35	302-6.47.034A		right side board weldment	1
29	36	302-6.47.305	FC302647305	limit board	2
29	37	GB5782-M10x30		Bolt M10x30	16
29	38	531-1704000		hinges	2
29	39	302-6.47.032		left bracket weldment	1
29	40	330A2-2200036		lock seat board	1
29	41	302-6.47.099		stay bar weldment	1
29	42	302-6.47.090A	FC302647090A	spring bar weldment	2
29	43	302-6.47.640	FC302647640	rubber pad	2
29	44	335A-2206000		left side board weldment	1
29	45	330E-2211000	FC330E2211000	headlight guard shield	2
29	46	330E-2401033	FC330E2401033	Lock button	1

# Parts Breakdown - Chassis

Fig.30 Left side

block assembly

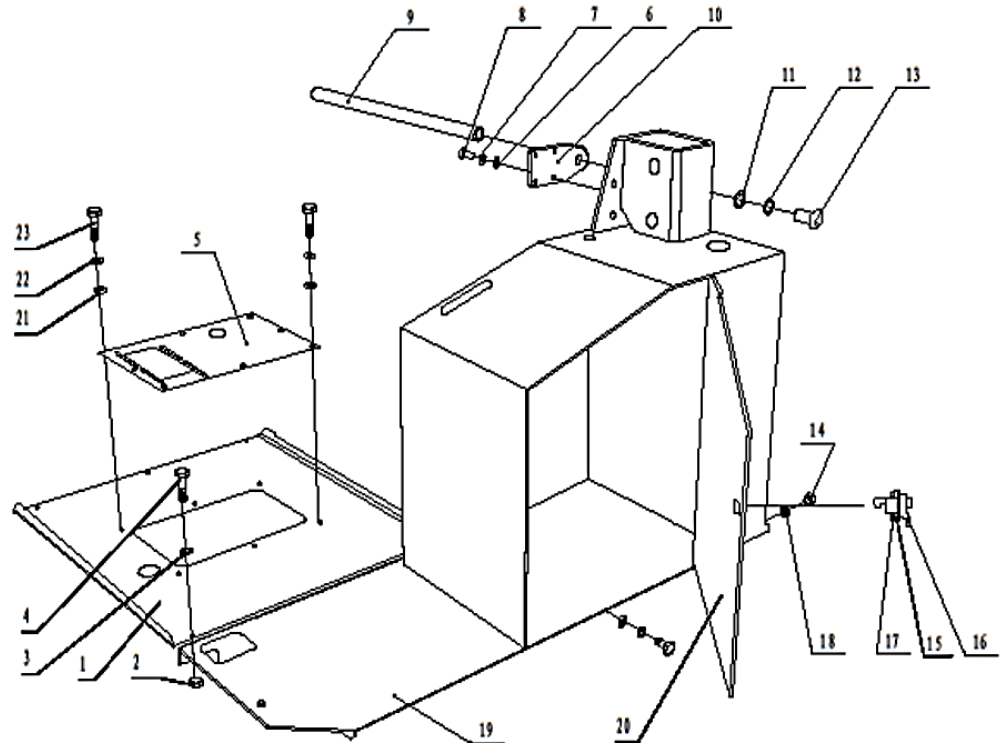

Fig#	Ref#	Mfg. Part#	NTE Part#	Description	Qty
30	1	330A3-2600001A		Base plate	1
30	2	GB6170-M8	FCGB6170M8	Nut 8	9
30	3	GB93-8		washer 8	9
30	4	GB5782-M8x20		Bolt M8x20	12
30	5	330A3-2601010		Cover weldment	1
30	6	GB97.1-12		washer 12	6
30	7	GB93-12		washer 12	6
30	8	GB5782-M12x30		Bolt M12x30	6
30	9	302-6.47.177		drawing bar	1
30	10	302-6.47.730	FC302647730	bar seat	1
30	11	GB97.1-20		washer 20	3
30	12	GB93-20		washer 20	3
30	13	GB5782-M20x30		Bolt M20x30	3
30	14	JB1000-M14x1.5	FCJB1000M1415	screw plug M14x1.5	1
30	15	GB93-5	FCGB935	washer 5	3
30	16	302-6.47.801	FC302647801	door lock for side box	1
30	17	GB/T65-M5x15		bolt M5x15	3
30	18	GB982-14	FCJB98214	washer 14	1
30	19	302-6.47.040A (335A-2301000)		left side block weldment	1
30	20	335A-2306000		Door weldment	1
30	21	GB97.1-6		washer 6	6
30	22	GB93-6		washer 6	6
30	23	GB818-M6x12		Screw M6x12	6

# Parts Breakdown - Chassis

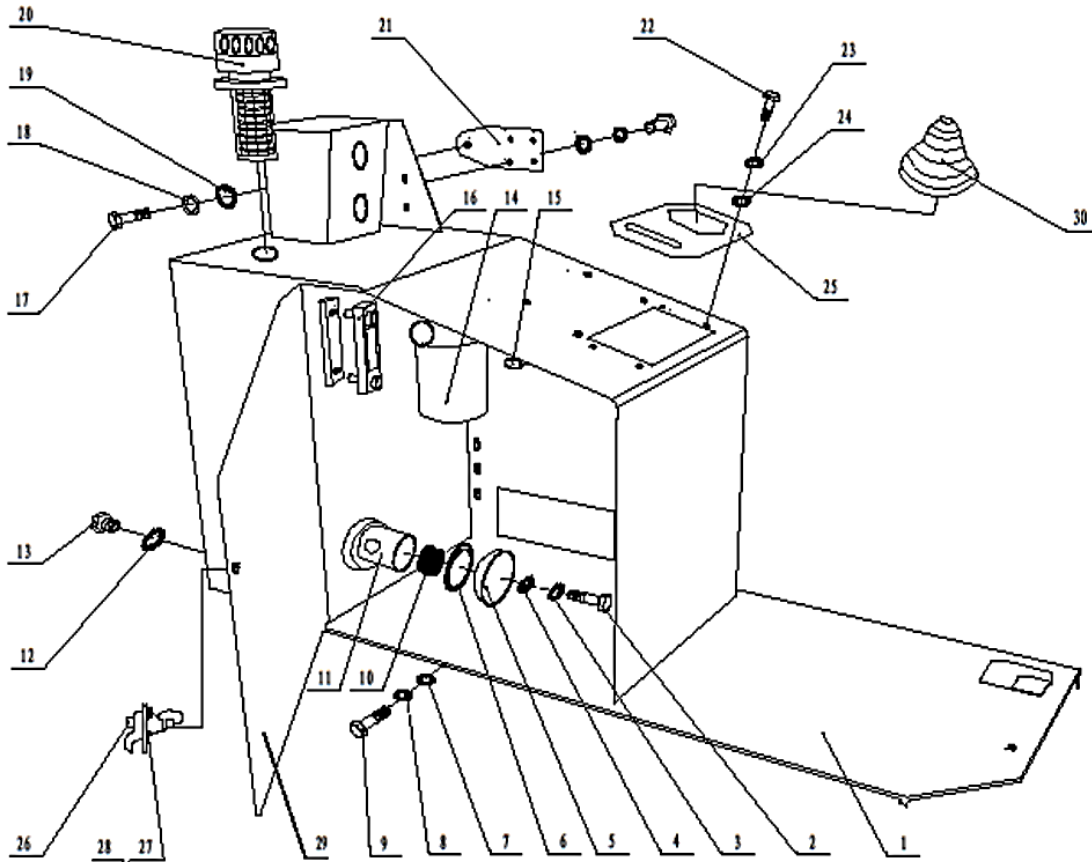

**Fig.31 right side block assembly**

Fig#	Ref#	Mfg. Part#	NTE Part#	Description	Qty
31	1	335A-2401000		right side block weldment	1
31	2	252L.58.505	FC252L58505	bolt	1
31	3	JB982-24	FCJB98224	seal washer 24	2
31	4	252L.58.515	FC252L58515	paper gasket	1
31	5	252L.58.516	FC252L58516	filter cover	1
31	6	252L.58.121		rubber washer	1
31	7	GB97.1-12		washer 12	8
31	8	GB93-12		washer 12	8
31	9	GB5782-M12x30		Bolt M12x30	8
31	10	252L.58.105	FC252L58105	filter spring	1
31	11	252L.58.058A	FC252L58058A	filter assembly	1
31	12	JB982-14	FCJB98214	seal washer 14	1
31	13	JB1000-M14x1.5	FCJB1000M1415	screw plug M14x1.5	1
31	14	SP-06X10	FCSP06X10	strainer	1
31	15	302-6.47.072		cappel	1
31	16	XYW-100	FCXYW100	hydraulic scale	1
31	17	GB5782-M20x30		Bolt M20x30	3
31	18	GB93-20		washer 20	3
31	19	GB97.1-20		washer 20	3

# Parts Breakdown - Chassis

---

<b>Fig#</b>	<b>Ref#</b>	<b>Mfg. Part#</b>	<b>NTE Part#</b>	<b>Description</b>	<b>Qty</b>
31	20	QUQ2-20X1.0	FCQUQ22010	hydraulic air cleaner	1
31	21	302-6.47.730	FC302647730	bar seat	1
31	22	GB818-M6x12		Screw M6x12	4
31	23	GB93-6		washer 6	4
31	24	GB97.1-6		washer 6	4
31	25	335A-2400036		top cover	1
31	26	302-6.47.801	FC302647801	door lock for side box	1
31	27	GB93-5	FCGB935	washer 5	3
31	28	GB/T65-M5x15		Slotting cheese head screw M5x15	3
31	29	335A-2306000		door	1
31	30	302-6.47.781		Dust proof cover	1

# Parts Breakdown - Chassis

Fig.32 Transom

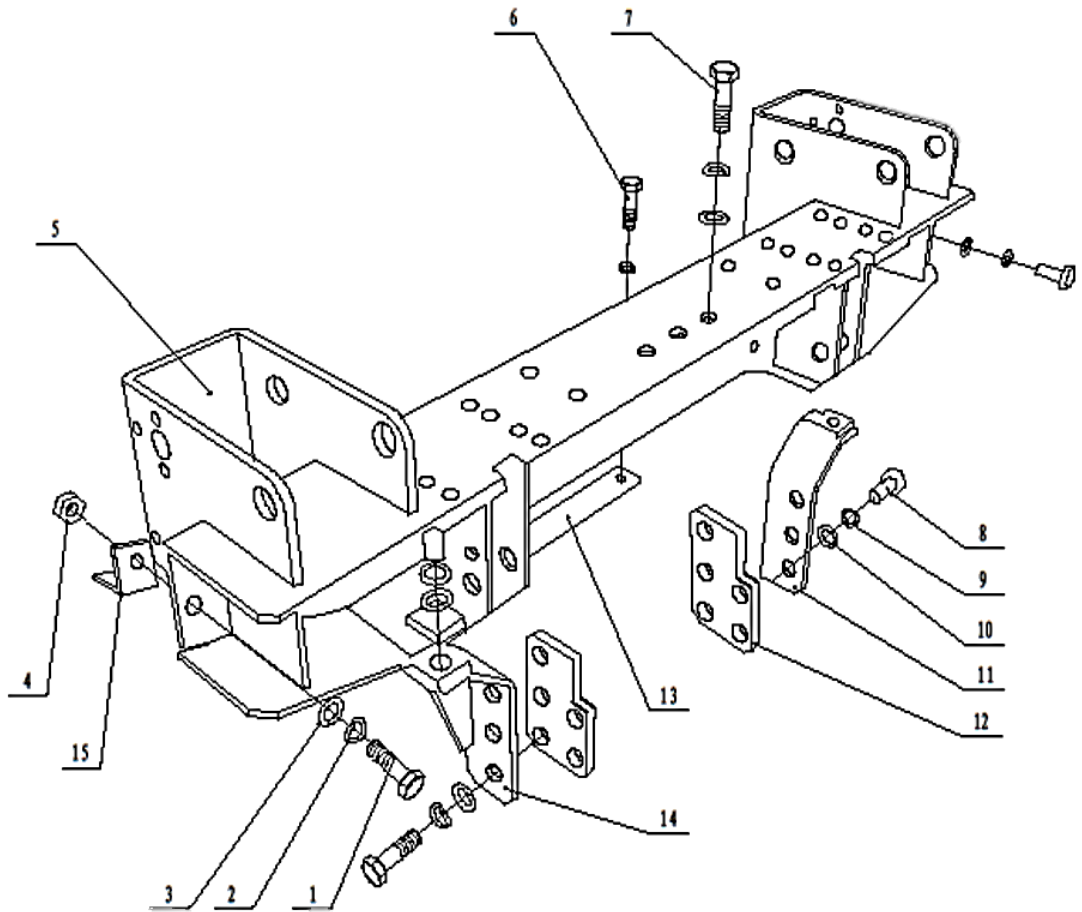

Fig#	Ref#	Mfg. Part#	NTE Part#	Description	Qty
32	1	GB5782-M12x30		Bolt M12x30	4
32	2	GB93-12		washer 12	6
32	3	GB97.1-12		washer 12	4
32	4	GB6170-M12		nut M12	4
32	5	302-6.47.051A	FC302647051A	transom weldment	1
32	6	GB5783-M12x40		bolt M12x40	2
32	7	GB5783-M16x40		bolt M16x40	5
32	8	GB5783-M16x45		bolt M16x45	6
32	9	GB93-16		washer 16	11
32	10	GB97.1-16		washer 16	5
32	11	302-6.47.053		transom left seat weldment	1
32	12	335A-2502004		connecting board	2
32	13	302-6.47.503A		plate	1
32	14	302-6.47.052		transom right seat weldment	1
32	15	302-6.47.501	FC302647501	Connect angle iron	2

# Parts Breakdown - Chassis

Fig.33 Electrical system and instrumentation

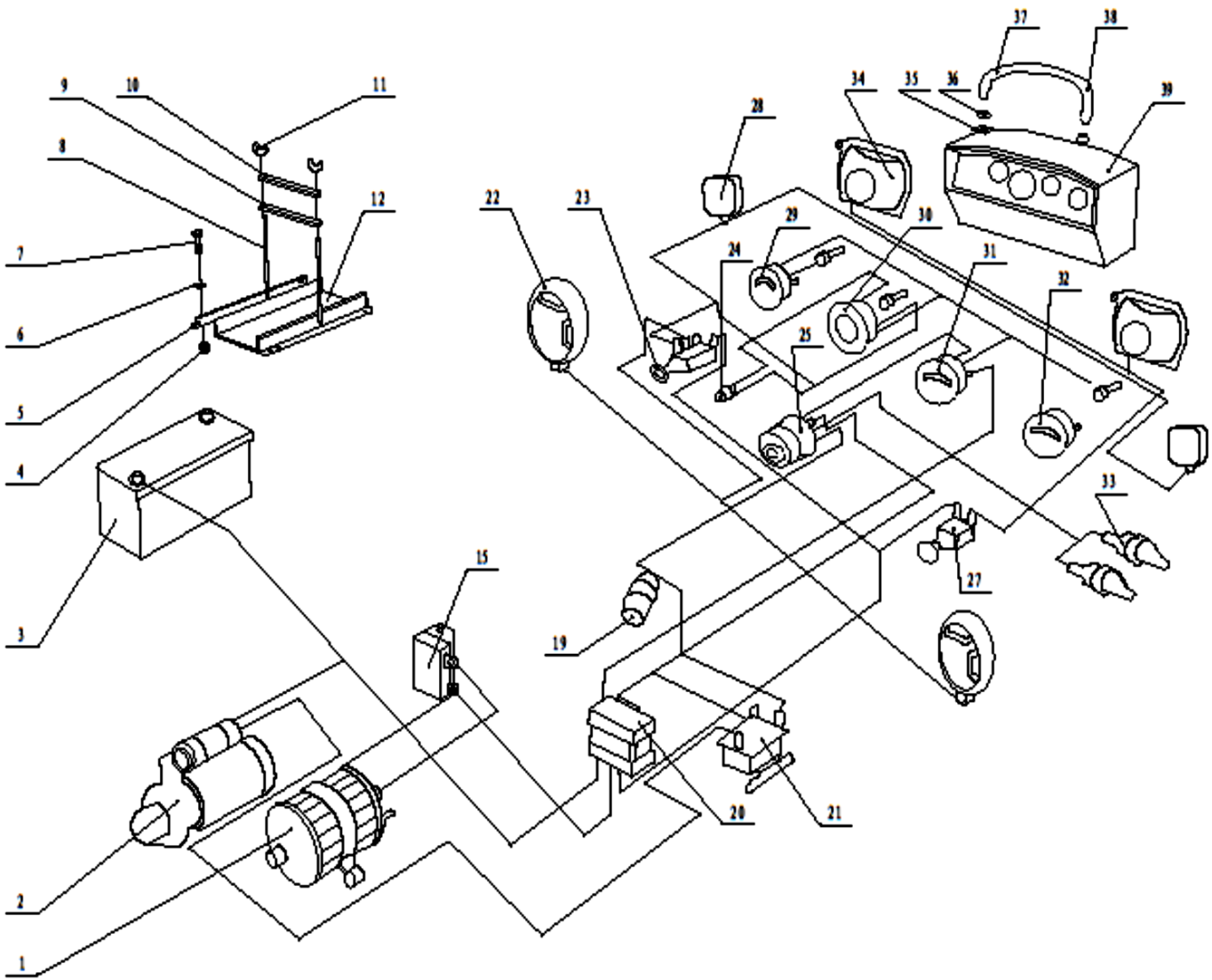

Fig#	Ref#	Mfg. Part#	NTE Part#	Description	Qty
33	1	JF121A-200W-14V	FCJF121A	alternator	1
33	2	QD152TD-12V	FCQDJ157Y12V	Starting motor 12V 3kw	1
33	3	110Ah		Battery 12V (LOCAL PURCHASE)	1
33	4	GB6170-M8	FCGB6170M8	nut M8	5
33	5	302-6.48.020		angle iron	2
33	6	GB93-8		washer 8	4
33	7	GB5783-M8x20		Bolt M8x20	4
33	8	302-6.48.703	FC302648703	hook	2
33	9	302-6.48.705		small rubber pad	1
33	10	302-6.48.706		splint	1

## Parts Breakdown - Chassis

---

Fig#	Ref#	Mfg. Part#	NTE Part#	Description	Qty
33	11	GB62-M8		nut M8	2
33	12	302-6.48.704	FC302648704	big rubber pad	1
33	15	JFT142A-14V	FCJFT142A14V	electronic-regulator	1
33	19	BJ1041	FCBJ1041	brake switch	1
33	20	BOX504	FCBOX504	Fuse box	1
33	21	JD131-12V	FCJD13112V	relay	1
33	22	1028V	FC1028V	taillight	2
33	23	JK107	FCJK107	2-shift switch	1
33	24	XDX1		power indicating light	1
33	25	JK290A	FCJK290A	preheating-start switch	1
33	27	JK106	FCJK106	1-shift switch	1
33	28	WD107X87-1	FCWD107X871	cab light	2
33	29	312-0-100PSI	FC3120100PSI	oil pressure gauge	1
33	30	ZX-12V-M18x1.5	FCZX12V	speed counter	1
33	31	311-A-1	FC311A1	ampere meter	1
33	32	313-A-1	FC313A1	water -thermometer	1
33	33	HS12V	FCHS12V	warm-up plug	1
33	34	SH50-12V	FCSH5012V	headlight	2
33	35	252L.48.504A-2		spacer block	2
33	36	GB6170-M8	FCGB6170M8	nut M8	2
33	37	252L.48.504A-1		armrest	1
33	38			pipe	1
33	39	302-6.48.710C		dashboard bracket weldment	1

# Parts Breakdown - Chassis

Fig.34 Fuel tank assembly

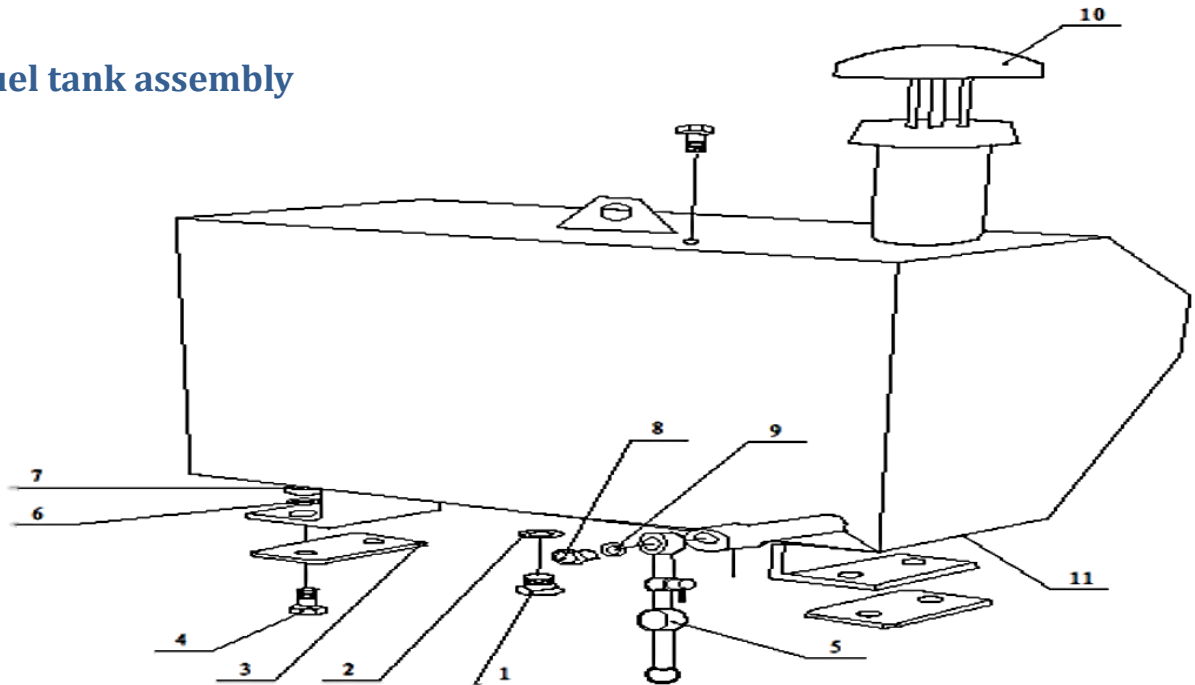

Fig#	Ref#	Mfg. Part#	NTE Part#	Description	Qty
34	1	302-6.50.101	FC302650101	screw plug M18x1.5	2
34	2	GB892-18	FCJB98218	seal washer 18	2
34	3	302-6.50.100		rubber pad	2
34	4	GB5783-M12x50		Bolt M12x50	4
34	5	302-6.50.09B	FC30265009B	oil tank connecting pipe	1
34	6	GB97.1-12		washer 12	4
34	7	GB6170-M8	FCGB6170M8	nut M8	8
34	8	330A3-3300001		bolt M14x1.5(L=25)	1
34	9	GB892-14	FCJB98214	seal washer 14	2
34	10	302-6.50.050C	FC302650050C	oil scale ( NLA) (Before Jan 2015)	1
34	10	302L.6.50.050C	FC302L650050C	FUEL CAP/GAUGE(SM INTERFACE)(Jan 2015 & after)	1
34		302-6.50.050D	FC302650050D	SMALL INTERFACE ADAPTER (To convert old tank to new cap)	
34	11	330A3-3301000	FC330A33301000	fuel tank weldment	1

# Parts Breakdown - Chassis

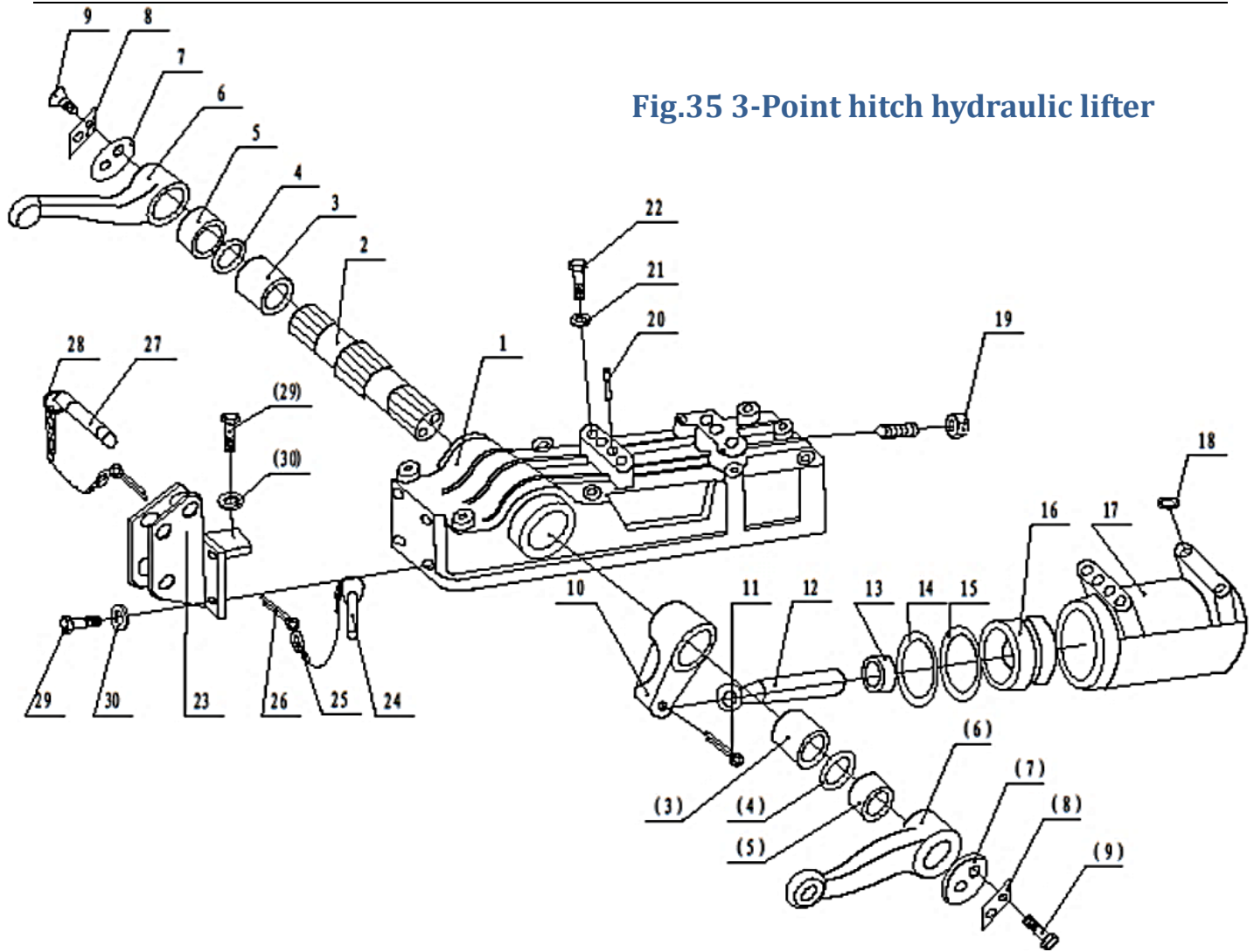

**Fig.35 3-Point hitch hydraulic lifter**

Fig#	Ref#	Mfg. Part#	NTE Part#	Description	Qty
35	1	252L.55.501A	FC252L55501A	lifter housing	1
35	2	252L.55.503	FC252L55503	lifter shaft	1
35	3	252L.55.504	FC252L55504	bushing	2
35	4	GB3452.1-60x5.7	FCGB345216057	O-ring 60x5.7	2
35	5	2552L.55.505	FC2552L55505	bushing	2
35	6	252L.55.053		lifting arm	2
35	7	252L.55.509	FC252L55509	locking piece for lifting arm	2
35	8	252L.55.510		locking piece	2
35	9	GB5782-M12x30		Bolt M12x30	4
35	10	252L.55.520	FC252L55520	inner lifting arm	1
35	11	GB91-5x60	FCGB91560	cotter pin 5x60	1
35	12	252L.55.521	FC252L55521	piston push rod	1
35	13	252L.55.517	FC252L55517	piston push rod bearing	1
35	14	252L.55.519	FC252L55519	elastic ring for piston	1
35	15	GB3452.1-80x5.7	FCGB345218057	O-ring 80x5.7	1

# Parts Breakdown - Chassis

Fig#	Ref#	Mfg. Part#	NTE Part#	Description	Qty
35	16	252L.55.516	FC252L55516	piston	1
35	17	252L.55.502	FC252L55502	cylinder barrel	1
35	18	GB1235-26x2.4	FCGB12352624	O-ring 26x2.4	1
35	19	GB6170-BM12		nut BM12	2
35	20	GB119-10jcx40	FCGB11910JC40	pin	2
35	21	GB93-16		washer 16	4
35	22	GB5782-M16x55		bolt M16x55	4
35	23	330E5-3501000A	FC330E53501000A	upper link support bracket	1
35	24	252L.55.028		chain link & locking pin assembly	1
35	25	252L.55.029	FC252L55029	small chain link assembly	2
35	26	GB91-5x20	FCGB91520	cotter pin 5x20	2
35	27	252L.55.127		upper link rear connecting pin	1
35	28	252L.55.128		connecting ring	1
35	29	GB5782-M12x25		Bolt M12x25	8
35	30	GB93-12		washer 12	8
35	31	GB75-M12x45		screw M12x45	2

**Fig.36**  
**Three-point hitch**  
**linkage and traction**  
**mechanism assembly**

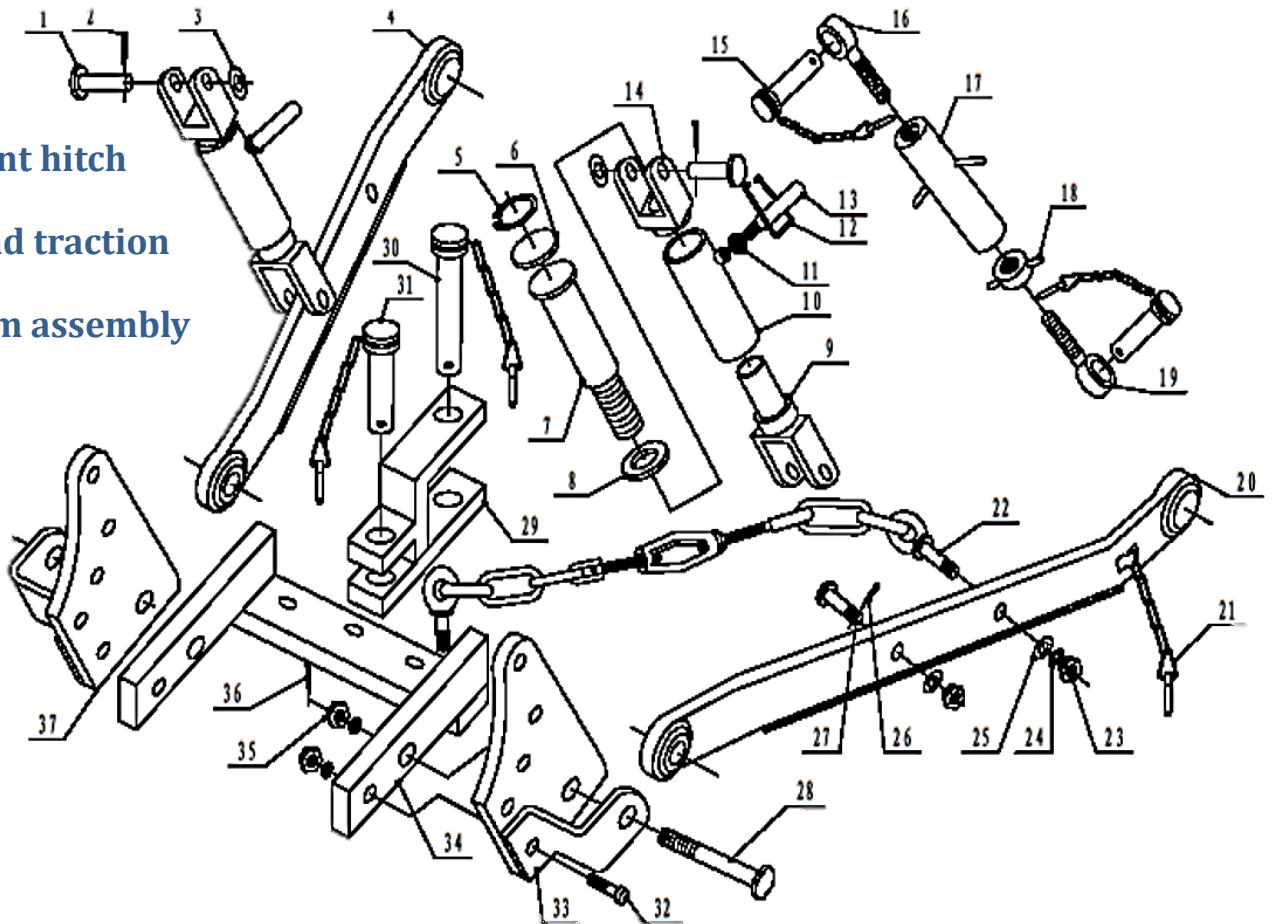

# Parts Breakdown - Chassis

Fig#	Ref#	Mfg. Part#	NTE Part#	Description	Qty
36	1	GB882-A16x70	FCGB882A1670	pin A16x70	2
36	2	GB91-4x20	FCGB91420	Cotter pin 4x20	2
36	3	GB95-16		washer 16	7
36	4	252L.56.062	FC252L56062	right lower link assembly	1
36	5	GB893-34	FCGB89334	elastic ring for hole 34	2
36	6	252L.56.509	FC252L56509	plug	2
36	7	252L.56.505	FC252L56505	bolt for lift link	1
36	8	252L.56.508		washer	2
36	9	252L.56.066	FC252L56066	lower part assembly of lift link	2
36	10	252L.56.067	FC252L56067	upper part assembly of lift link	2
36	11	GB6170-M10		nut M10	2
36	12	252L.56.507		locking ring	2
36	13	252L.56.506		handle	2
36	14	252L.56.504	FC252L56504	upper part of lift link	2
36	15	252L.56.023		rear connecting pin with locking pin assembly	1
36	16	252L.56.064	FC252L56064	front adjusting bolt assembly of upper link	2
36	17	252L.56.065	FC252L56065	adjusting threaded pipe assembly	1
36	18	252L.56.503	FC252L56503	locking nut	1
36	19	252L.56.063	FC252L56063	rear adjusting rod assembly of upper linkage	1
36	20	252L.56.061	FC252L56061	left lower link assembly	1
36	21	252L.56.025		locking pin assembly for lower link	4
36	22	252L.56.057	FC252L56057	Chain assembly	2
36	23	GB6170-M16		nut M16	8
36	24	GB97.1-16		washer 16	8
36	25	GB93-16		washer 16	8
36	26	GB91-4x20	FCGB91420	Cotter pin 4x20	2
36	27	GB882-A16dx55	FCGB882A16D55	pin A16dx55	2
36	28	252L.56.505	FC252L56505	bolt for lift link	2
36	29	252L.56.502	FC252L56502	drawing hook	1
36	30	252L.56.060	FC252L56060	drawing pin with locking pin assembly	1
36	31	252L.56.059	FC252L56059	front drawing pin with locking pin assembly	1
36	32	GB5782-M16x60	FCGB5782M1660	Bolt M16x60	2
36	33	252L.56.055	FC252L56055	left connecting plate assembly	1
36	34	252L.56.058	FC252L56058	traction frame assembly	1
36	35	GB59-M16	FCGB6170M16	nut M16	2
36	36	GB91-4x35	FCGB91435	Cotter pin 4x35	2
36	37	252L.56.056	FC252L56056	right connecting plate assembly	1

# Parts Breakdown - Chassis

**Fig.37 Hydraulic control lever - STRAIGHT BLADE**

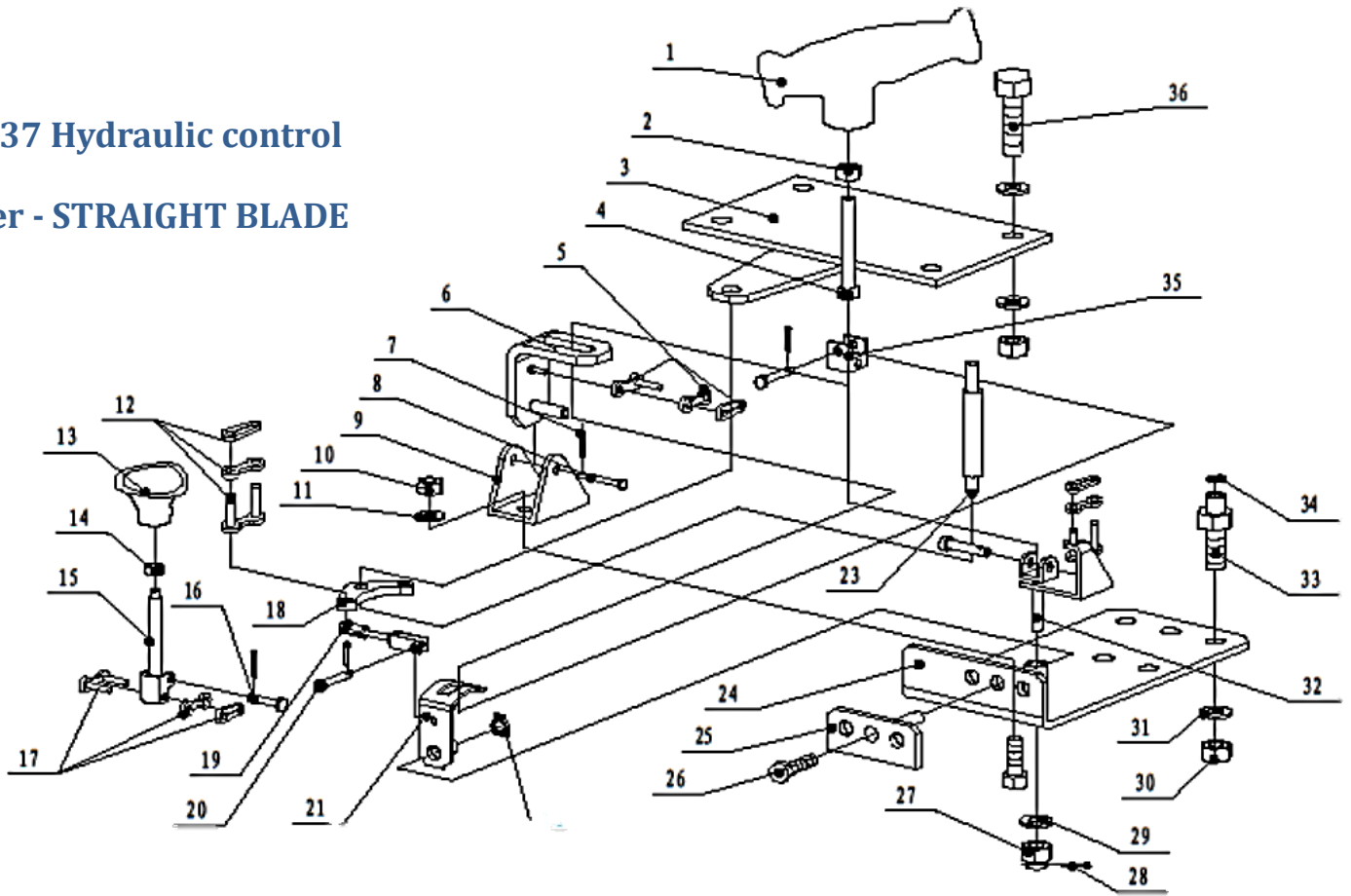

Fig#	Ref#	Mfg. Part#	NTE Part#	Description	Qty
37	1	302-6.57.015A		handle weldment	1
37	2	302-6.57.016	FC302657016	bracket weldment	1
37	3	GB6173-M14x1.5		nut M14x1.5	1
37	4	302-6.57.126A	FC302657126A	lever	1
37	5	302-6.57.017	FC302657017	link (1)	1
37	6	302-6.57.011A	FC302657011A	rocker (1)	1
37	7	GB882-B6x35		pin B6x35	1
37	8	302-6.57.120A	FC302657120A	bracket	1
37	9	GB91-2x14	FCGB91214	cotter pin 2x14	6
37	10	GB6170-M10		nut M10	7
37	11	GB93-10		washer 10	7
37	12	302-6.57.014	FC302657014	link (2)	2
37	13	302-6.57.148	FC302657148	knob	1
37	14	GB6171-M10		nut 10	1
37	15	302-6.57.019		lever	1
37	16	GB882-B6x20	FCGB882B620	cotter pin B6x20	4
37	17	302-6.57.020		link (3)	1
37	18	302-6.57.140	FC302657140	rocker lever	1

## Parts Breakdown - Chassis

---

Fig#	Ref#	Mfg. Part#	NTE Part#	Description	Qty
37	19	302-6.57.124	FC302657124	rod	1
37	20	GB882-B6x16	FCGB882B616	cotter pin B6x16	1
37	21	302-6.57.012A	FC302657012A	rocker (2)	1
37	22	GB894.1-10	FCGB894110	elastic ring 10	1
37	23	302-6.57.122A	FC302657122A	shaft	1
37	24	302-6.57.010A	FC302657010A	bracket weldment	1
37	25	302-6.57.018	FC302657018	support axle	1
37	26	GB5783-M10x20		bolt M10x20	1
37	27	GB6178-M10		nut M10	1
37	28	GB91-2x24	FCGB91224	cotter pin 2x24	1
37	29	GB97-10		washer 10	5
37	30	GB6173-M18x1.5		nut M18x1.5	4
37	31	GB93-18		washer 18	4
37	32	302-6.57.013	FC302657013	yoke	1
37	33	302-6.57.128A	FC302657128A	fitting	6
37	34	JB982-18	FCJB98218	seal washer 18	6
37	35	302-6.57.125	FC302657125	yoke	1
37	36	GB5782-M10x70		bolt M10x70	3

# Parts Breakdown - Chassis

Fig.38 Six-action Blade -  
STRAIGHT BLADE

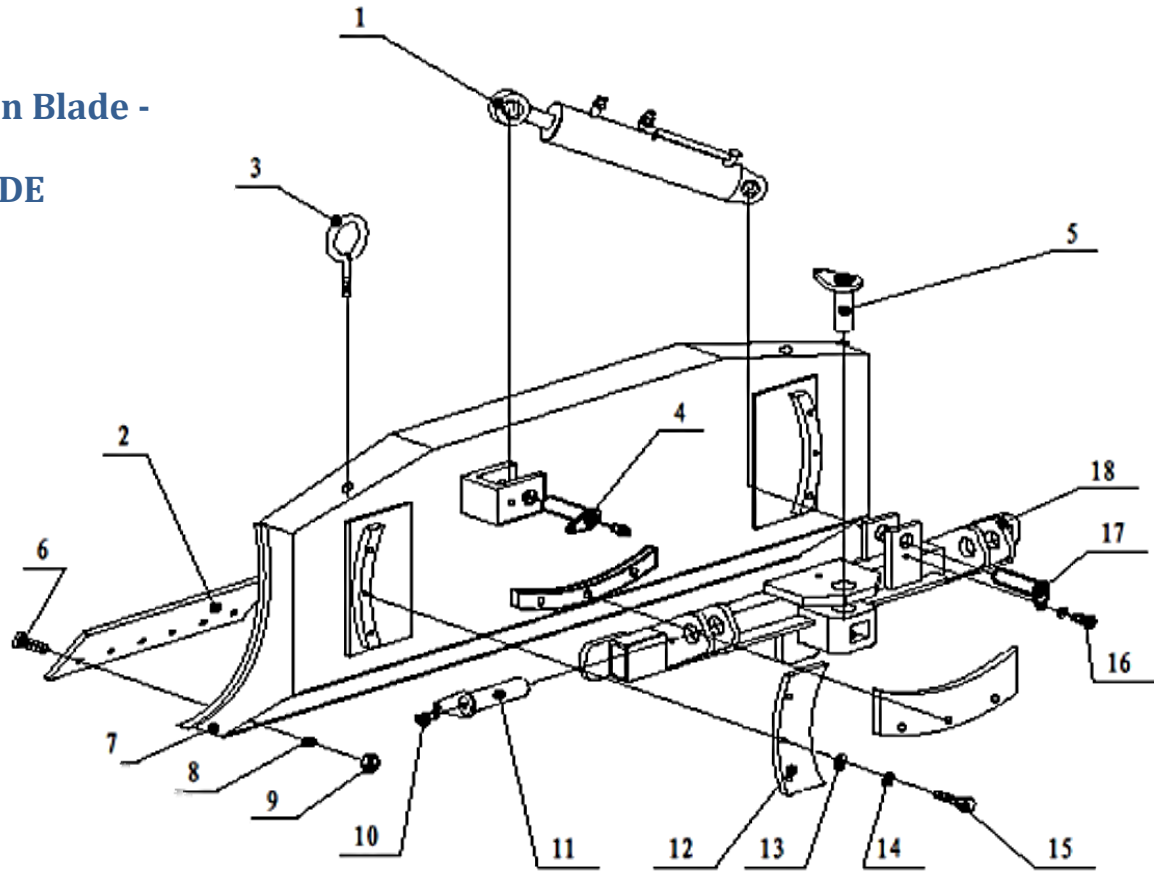

Fig#	Ref#	Mfg. Part#	NTE Part#	Description	Qty
38	1	330A-5114000	FC330A5114000	tilting cylinder	1
38	2	302-4.75.137	FC302475137	cutting edge (1)	3
38	3	GB852-76		eye bolt	2
38	4	330E5-5125000	FC330E55125000	pin	1
38	5	330E5-5121000	FC330E55121000	pin	1
38	6	GB10-M12x40		bolt M12x40	15
38	7	402L.75.011C	FC402L75011C	blade weldment	1
38	8	GB93-12		washer	20
38	9	GB6172-M12		nut M12	15
38	10	GB1152-M10x1	FCGB1152M101	grease cup M10x1	1
38	11	330E5-5123000	FC330E55123000	pin	2
38	12	252L-4.75.135		pressure plate	3
38	13	GB95-16		washer 16	11
38	14	GB93-16		washer 16	11
38	15	GB5782-M16x45		Bolt M16x45	9
38	16	GB5782-M12x25		Bolt M12x25	5
38	17	330E5-5122000	FC330E55122000	pin	2
38	18	302L-5.75.020	FC302L575020	frame weldment	1

# Parts Breakdown - Chassis

**Fig.39 blade  
bracket**

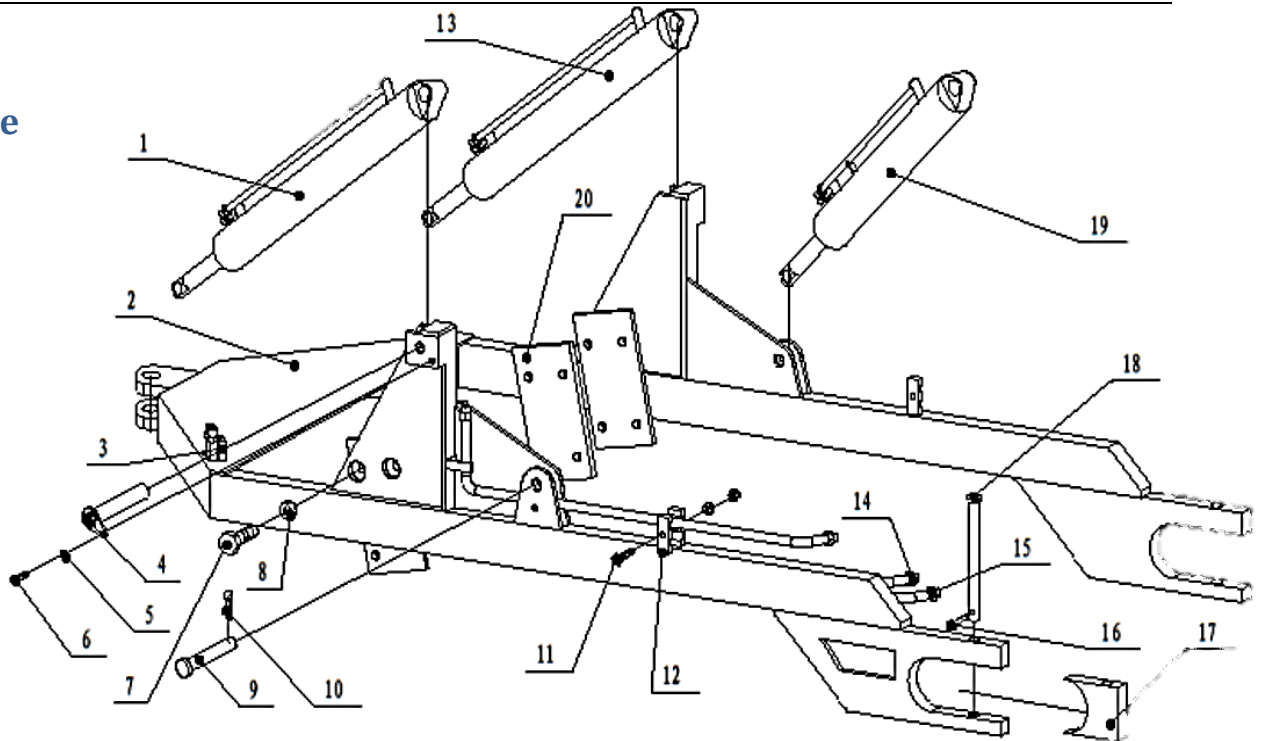

Fig#	Ref#	Mfg. Part#	NTE Part#	Description	Qty
39	1	330A-5111000	FC330A5111000	left rotary cylinder assembly	1
39	1.1	330A-5111000-1	FC330A51110001	Left swing cylinder seals	
39	2	302-6.75.030	FC302675030	blade bracket weldment	1
39	3	302-6.75.412		Pipe clamp(2)	1
39	4	330E5-5124000		pin	2
39	5	GB93-8		washer 8	5
39	6	GB5782-M8x25		Bolt M8x25	2
39	7	GB5782-M12x30		Bolt M12x30	8
39	8	GB93-12		washer 12	8
39	9	252L-4.75.112	FC252L475112	pin (2)	2
39	10	GB91-4x35	FCGB91435	Cotter pin 4x35	2
39	11	GB5782-M8x35		bolt M8x35	3
39	12	302-6.75.411		Pipe clamp(1)	2
39	13	330A-5112000	FC330A5112000	right rotary cylinder	1
39	13.1	330A-5112000-1	FC330A51120001	Right swing cylinder seals	
39	14	302L-5.75.063		oil pipe(2)	2
39	15	302L-5.75.062		oil pipe(1)	2
39	16	GB91-5x35		cotter pin 5x35	2
39	17	252L-4.75.114	FC252L475114	semi-circle seat	2
39	18	GB882 (model B) 22x140		pin 22x140	2
39	19	330A-5113000	FC330A5113000	lifting cylinder assembly	2
39	19.1	330A-5113000-1	FC330A51130001	Lift cylinder seals	
39	20	302-6.75.237		Shovel location-limited plate	2

# Parts Breakdown - Chassis

**Fig.40 Hydraulic tank and lines**

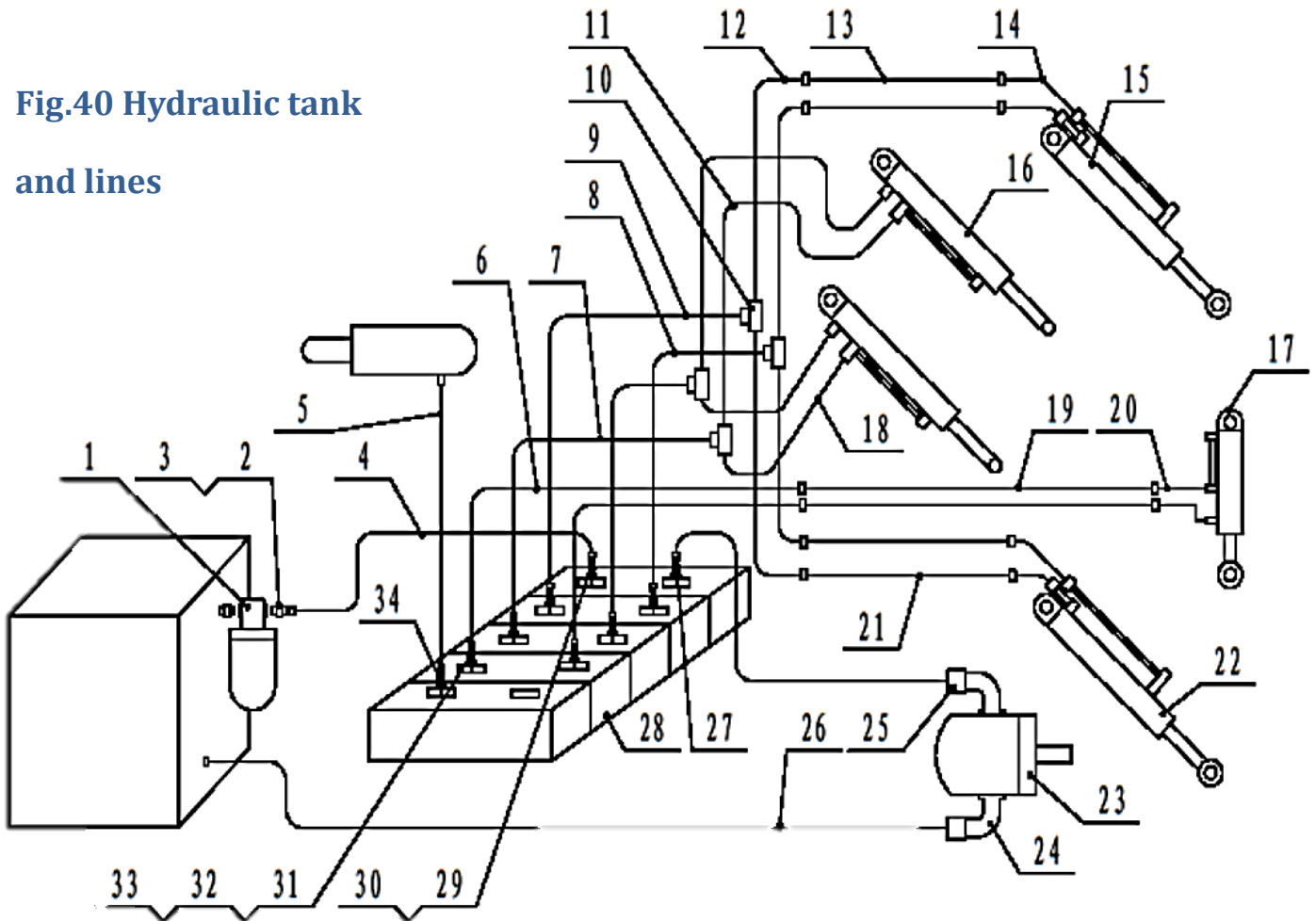

Fig#	Ref#	Mfg. Part#	NTE Part#	Description	Qty
40	1	SP-06X10	FCSP06X10	strainer	1
40	2	330A-3700015		inlet	1
40	3	GB3452.1-	FCGB3452115265	O-ring 15x2.65	3
40	4	330A-3743000	FC330A3743000	Return hose	1
40	5	330A-3738000	FC330A3738000	Lifting hose	1
40	6	330A-3742000	FC330A3742000	Pipe(1) for tilt cylinder	2
40	7	330A-3732000	FC330A3732000	Lifting hose	2
40	8	330A-3734000	FC330A3734000	Swing hose 1-1	1
40	9	330A-3735000	FC330A3735000	Swing hose 1-2	1
40	10	252L-4.57.582	FC252L457582	Cappel	4
40	11	330A-3742000	FC330A3742000	Lifting hose 2-left	2
40	12	330A-3734000	FC330A3734000	Swing hose 2-right	2
40	13	302L-5.57.063		Oil pipe III	2
40	14	330A-3736000	FC330A3736000	Swing hose	4
40	15	330A-5111000	FC330A5111000	Left swing cylinder	1
40	15.1	330A-5111000-1	FC330A51110001	Left swing cylinder seals	

# Parts Breakdown - Chassis

Fig#	Ref#	Mfg. Part#	NTE Part#	Description	Qty
40	16	330A-5113000	FC330A5113000	Lift cylinder	2
40	16.1	330A-5113000-1	FC330A51130001	Lift cylinder seals	
40	17	330A-5114000	FC330A5114000	Tilt cylinder	1
40	18	330E5-4003000	FC330E54003000	Lifting hose 2-right	2
40	19	302L-5.75.061	FC302L575061	Oil pipe II	2
40	20	330A-3737000	FC330A3737000	Tilt pipe	2
40	21	302L-5.57.062	FC302L557062	Oil pipe I	2
40	22	330A-5112000	FC330A5112000	Right swing cylinder	1
40	22.1	330A-5112000-1	FC330A51120001	Right swing cylinder seals	
40	23	CBT-F314	FCCBTF314	Gear pump	1
40	24	335A-3708000	FC335A3708000	Fitting for gear pump inlet	1
40	25	335A-3707000	FC335A3707000	Fitting for gear pump outlet	1
40	26	330A-3739000	FC330A3739000	Suction hose assembly	1
40	27	Z05.57-21		Capple	1
40	28	DF450G	FCDF450G	Hydraulic valve	1
40	29	Z05.57-22		Capple	1
40	30	GB982-22	FCJB98222	Seal washer 22	2
40	31	302-6.57.128		Fitting	5
40	32	GB982-18	FCJB98218	Seal washer 18	5
40	33	GB3452.1-8x1.8	FCGB34521818	O-ring 8x1.8	32
40	34	252L-4.57.502	FC252L457502	Capple	1

**Fig.41 Hand brake**

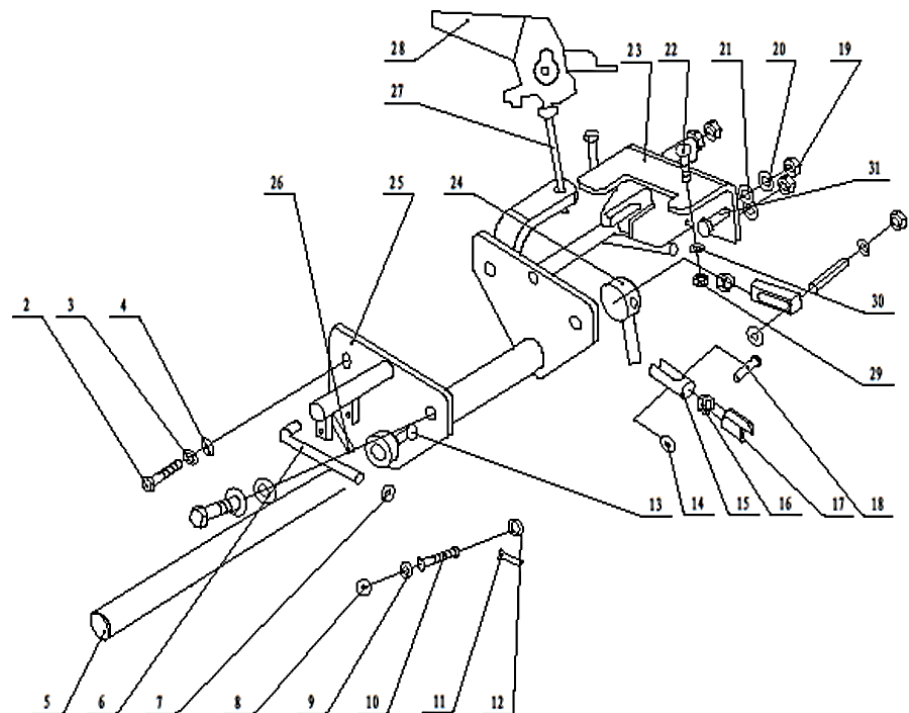

## Parts Breakdown - Chassis

Fig#	Ref#	Mfg. Part#	NTE Part#	Description	Qty
41	2	GB5782-M12x40		Bolt M12x40	4
41	3	GB93-12		washer 12	4
41	4	GB97.1-12		washer 12	4
41	5	330A3-1800001	FC330A31800001	Universal drive shaft	1
41	6	330A3-1800002	FC330A31800002	Brake pulling bar	2
41	7	GB6170-M10		nut 10	2
41	8	GB6170-M8	FCGB6170M8	nut 8	2
41	9	GB93-8		washer 8	2
41	10	330A3-1800004	FC330A31800004	Fixing bar	2
41	11	GB91-A3x20	FCGB91A320	Cotter pin A3x20	5
41	12	GB97.1-10		washer 10	4
41	13	GB879-8x45	FCGB879845	Elastic pin	3
41	14	GB97.1-8		washer 8	1
41	15	330A3-1800006		Adjusting bar	1
41	16	GB6170-M10		nut 10	1
41	17	330A3-1800007	FC330A31800007	Adjusting bar	1
41	18	GB882-A8x30	FCGB882A830	Pin A8x30	1
41	19	GB6170-M10		nut 10	2
41	20	GB93-10		washer 10	2
41	21	GB97.1-10		washer 10	2
41	22	GB5782-M8x30		Bolt M8x30	2
41	23	330A3-1802000	FC330A31802000	Pulling arm seat	1
41	24	330A3-1804000	FC330A31804000	Universal lever weldment II	1
41	25	330E5-1801000A		Hand brake fixing seat	1
41	26	330A3-1803000	FC330A31803000	Universal lever weldment I	2
41	27	330A3-1800008	FC330A31800008	Drawing rope for hand brake	1
41	28	330A3-1800012	FC330A31800012	Handle for hand brake	1
41	29	GB6170-M8	FCGB6170M8	nut 8	2
41	30	GB93-8		washer 8	2
41	31	GB5782-M10x30		Bolt M10x30	2

# Parts Breakdown - Engine

---

## NorTrac 35XTD Crawler-Dozer: Item# 24549 - Engine

Fig 1 - Cylinder Block Assembly 1 .....	128
Fig 2 - Cylinder Block Assembly 2 .....	130
Fig 3 - Cylinder Block Assembly 3 – Engine Oil Sump .....	132
Fig 4 - Cylinder Block Assembly 4 – Flywheel Housing .....	132
Fig 5 – Cylinder Block Assembly 5 – Front Engine Cover Assembly .....	133
Fig 6 - Timing Gear & Camshaft Assembly .....	135
Fig 7 - Cylinder Head Assembly .....	136
Fig 8 - Piston & Connecting Rod Assembly .....	138
Fig 9 - Crankshaft & Flywheel Assembly .....	139
Fig 10 - Cooling System Assembly .....	140
Fig 11 - Intake Manifold Assembly .....	141
Fig 12 - Exhaust Manifold Assembly .....	142
Fig 13 - Lubricating System Assembly .....	143
Fig 14 - Fuel System Assembly .....	144
Fig 15 – Engine Electrical Components .....	145

# Parts Breakdown - Engine

Fig 1 - Cylinder Block Assembly 1

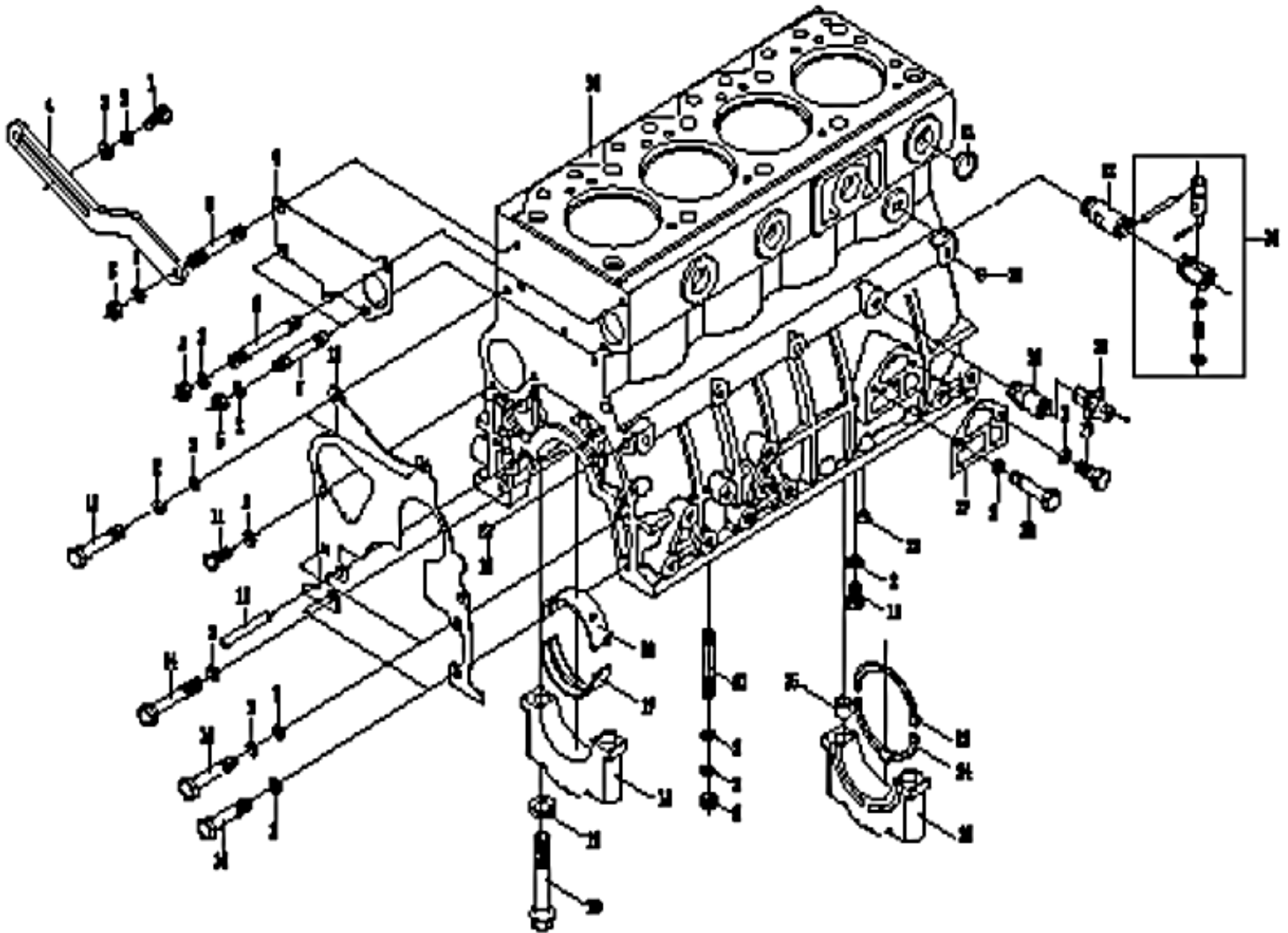

Fig#	Ref#	Mfg. Part#	NTE Part#	Description	Qty
1	1	GB5783-M8x35		Bolt M8x35	1
1	2	GB93-8		Washer 8	35
1	3	GB97.1-8		Washer 8	21
1	4	4L22BT-01029	FC4L22BT01029	Alternator adjustable support	1
1	5	GB6170-M8		Nut M8	20
1	6	GB898-M8x65		Bolt M8x65	1
1	7	GB898-M8x60		Bolt M8x60	2
1	8	GB898-M8x90		Bolt M8x90	1

## Parts Breakdown - Engine

Fig#	Ref#	Mfg. Part#	NTE Part#	Description	Qty
1	9	4L22-01006	FC4L2201006	Water rear cover gasket	1
1	10	GB5782-M8x55		Bolt M8x55	4
1	11	GB5783-M8x20		Bolt M8x20	5
1	12	L375-01007	FCL37501007	Gear case cover gasket	1
1	13	GB119-B8x50		Pin B8x50	1
1	14	GB5782-M8x45		Bolt M8x45	4
1	15	L375-01104		Main bearing stopper	1
1	16	4L22-01015	FC4L220101516	Main bearing (upper shell)	5
1	17	4L22-01016	use FC4L220101516	Main bearing (lower shell)	5
1	18	4L22BZ-01112		Main bearing cap	4
1	19	4L22BZ-01113		Washer of Main bearing cap bolt	10
1	20	4L22BZ-01114		Main bearing cap bolt	10
1	21	GB898-M8x16		Bolt M8x16	16
1	22	D495QB-03109		Blind plug $\phi$ 12	1
1	23	4L22-01007	FC4L22010078	Upper thrust piece of crankshaft	2
1	24	4L22-01008	use FC4L22010078	Lower thrust piece of crankshaft	2
1	25	L375-01106		Locating sleeve of main bearing cap	2
1	26	4L22BZ-01113		Rear main bearing cap	1
1	27	L375-01027	FCL37501027	Oil filter gasket	1
1	28	GB5782-M8x50		Bolt M8x50	1
1	29	GB5783-M8x25		Bolt M8x25	1
1	30	L375-01035	FCL37501035	Oil pressure indicator joint	1
1	31	L375-01105-1		Taper plug	4
1	32	D495QB-01024		Blind plug $\phi$ 32	4
1	33	LL380BD-01033		Water drain cock joint	1
1	34	195N-15200		Water drain cock	1
1	35	L375-12400	FCHXYG01	Sensor, Oil Pressure gauge	1
1	36	4L22BT-01111		Cylinder block	1

# Parts Breakdown - Engine

Fig 2 - Cylinder

Block Assembly 2

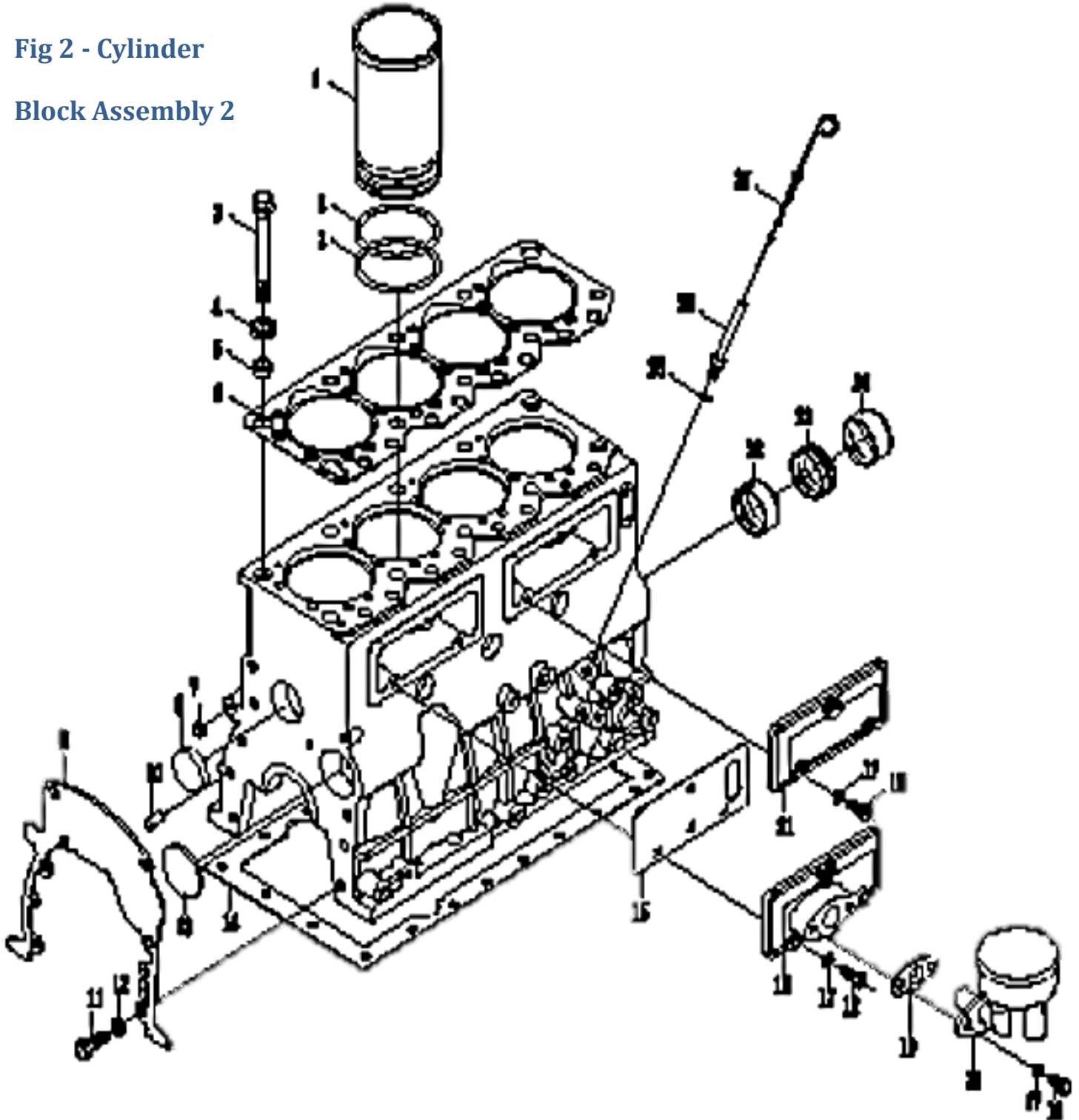

Fig#	Ref#	Mfg. Part#	NTE Part#	Description	Qty
2	1	4L22-01003	FC4L2201003	Cylinder liner	4
2	2	L380-01002		Seal ring of cylinder liner	8
2	3	4L22-01005	FC4L2201005	Cylinder head stud	10
2	4	4L22-01024		Washer of cylinder head stud	10

# Parts Breakdown - Engine

Fig#	Ref#	Mfg. Part#	NTE Part#	Description	Qty
2	5	L375-01103		Locating sleeve	2
2	6	L480Q-01002	FC4L22010021	Cylinder head gasket	1
2	7	L375-01104		Main oil chanel plug	1/2
2	8	D495QB-01024		Blind plug $\phi$ 32	
2	9	4L22BT-01018-1	FC4L22BT010181	Flywheel housing gasket	1
2	10	GB119-B10x20		Pin B10x20	
2	11	GB5783-M10x30		Bolt M10x30	9/14
2	12	GB93-10		Washer 10	9/14
2	13	L375-01102	FCL37501102	Plug $\phi$ 55	1
2	14	4L22-01017	FC4L22BT01017	Oil sump gasket	1
2	15	LL480-01014	FCLL48001014	Side cover spacer	2
2	16	4L22-01013	FC4L2201013	Side cover (II)	1
2	17	GB93-8		Washer 8	12/50
2	18	GB5783-M8x25		Bolt M8x25	6/30
2	19	LL480-01011		Breather housing gasket	1
2	20	D495QB-012104		Breather housing	1
2	21	LL480-01012	FCLL48001012	Side cover (I)	1
2	22	4L22-01117		Rear bushing of camshaft	1
2	23	4L22-01116		Middle bushing of camshaft	1
2	24	4L22-01115		Front bushing of camshaft	1
2	25	195-13007		Gasket	1
2	26	LL385T-01320-01320		Dipstick sleeve weldment	1
2	27	LL385BT-01322		Oil dipstick part	1

# Parts Breakdown - Engine

**Fig 3 – Cylinder Block Assembly 3 –  
Engine Oil Sump**

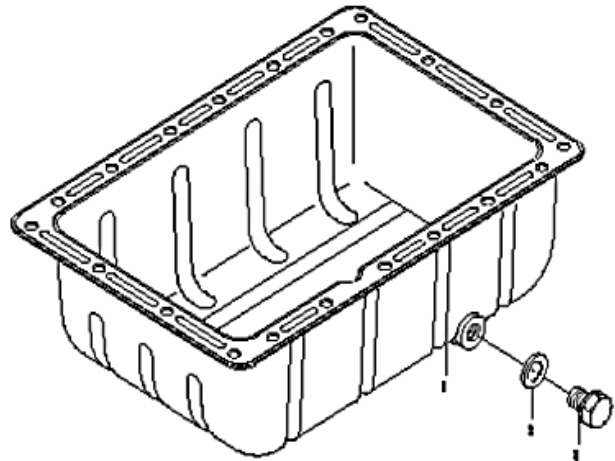

Fig#	Ref#	Mfg. Part#	NTE Part#	Description	Qty
3	1	4L22BT-01500-2		Oil sump	1
3	2	LL380-01503	FCLL38001503	A type washer	1
3	3	LL380-01501	FCLL38001501	Oil drain plug	1

**Fig 4 - Cylinder Block Assembly 4 –  
Flywheel Housing**

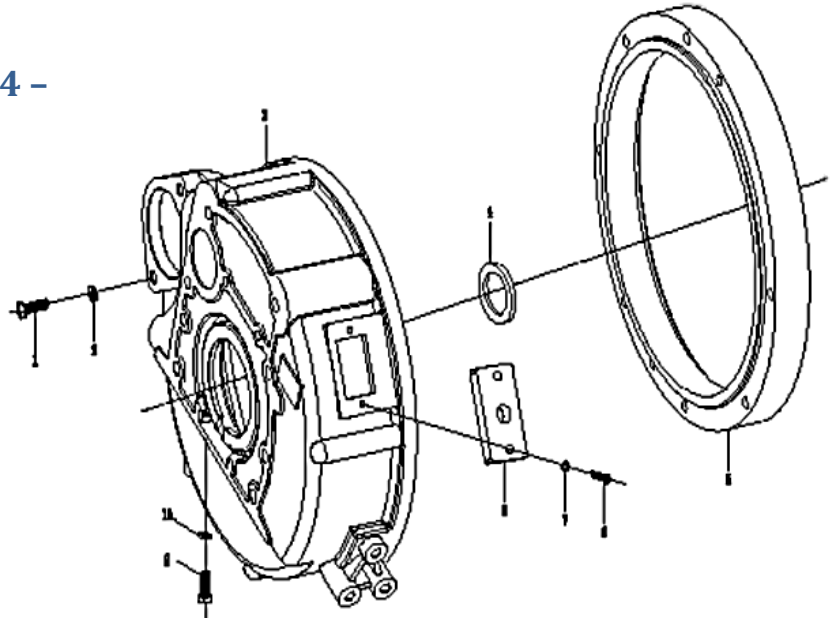

Fig#	Ref#	Mfg. Part#	NTE Part#	Description	Qty
4	1	GB5783-M10x30		Bolt M10x30	2
4	2	GB93-10		Washer 10	2
4	3	4L22BT-01010		Flywheel housing	1
4	4	JB2600-80-DL80x100x12	FCDL8010012	Oil seal DL80x100x12	1
4	5	LL380D-01701		Flywheel housing connect plate	1
4	6	GB5783-M6x20		Bolt M6x20	2
4	7	GB93-6		Washer 6	2
4	8	LL480-01025		Cover board	1
4	9	GB5783-M8x18		Bolt M8x18	4
4	10	GB93-8		Washer 8	4

# Parts Breakdown - Engine

Fig 5 - Cylinder Block Assembly 5 - Front Engine Cover Assembly

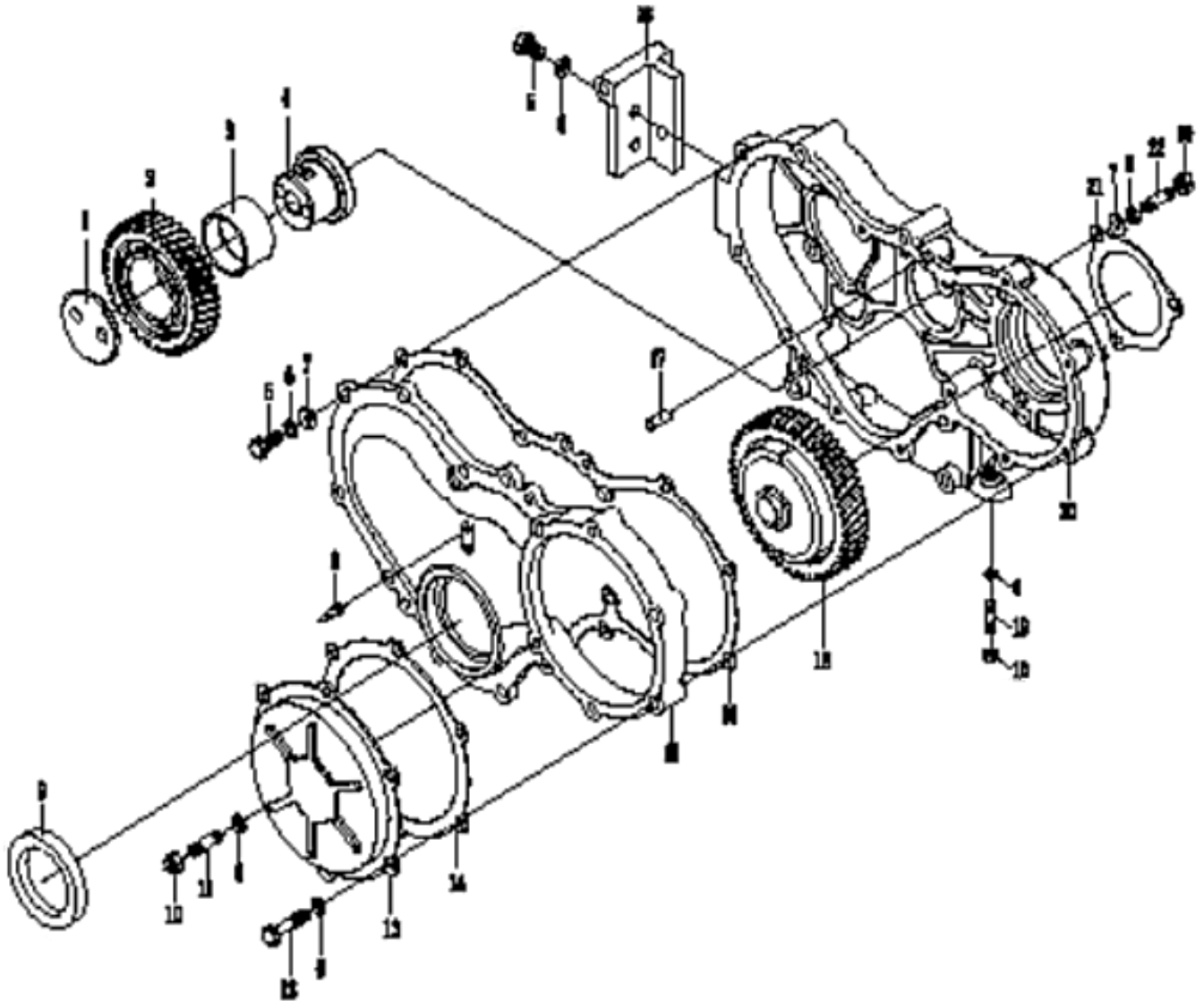

Fig#	Ref#	Mfg. Part#	NTE Part#	Description	Qty
5	1	4L22BT-01020	FC4L22BT01020	Idle gear hold-down	1
5	2	4L22BT-01201		Idle gear	1
5	3	4L22BT-01202		Idle gear bushing	1
5	4	4L22BT-01015	FC4L22BT01015	Idle gear shaft	1
5	5	GB5783-M8x20		Bolt M8x20	10
5	6	GB93-8		Washer 8	23
5	7	GB97.1-8-100HV		Washer 8-100HV	20
5	8	L375-01034		Upper death piont showing needle	1
5	10	GB6170-M8		Bolt M8	5
5	11	GB898-M8x40		Bolt M8x40	1
5	12	GB5782-M8x40		Bolt M8x40	5

# Parts Breakdown - Engine

Fig#	Ref#	Mfg. Part#	NTE Part#	Description	Qty
5	13	4L22BT-01025	FC4L22BT01025	Gear case front cover	1
5	14	4L22BT-01030	FC4L22BT01030	Gear case front cover gasket	1
5	15	4L22BT-01008	FC4L22BT01008	Timing gear case cover	1
5	16	4L22BT-01009	FC4L22BT01009	Timing gear case cover gasket	1
5	17	GB119-B8x18		Pin B8x18	1
5	18	L480Q-109000		Timing advance assembly	1
5	1	L375-01014		Idle gear hold-down	1
5	2	L375-01201		Idle gear	1
5	3	L375-01202		Idle gear bushing	1
5	4	LL480-01015		Idle gear shaft	1
5	5	GB5783-M8x20		Bolt M8x20	10
5	6	GB93-8		Washer 8	23
5	7	GB97.1-8-100HV		Washer 8-100HV	20
5	8	L375-01034		Top dead center indicator	1
5	9	JB2600-80-DR55x75x12	FCDR557512	Oil seal DR55x75x12	1
5	10	GB6170-M8		Bolt M8	5
5	11	GB898-M8x40		Bolt M8x40	1
5	12	GB5782-M8x40		Bolt M8x40	5
5	13	L375-01025		Gear case front cover	1
5	14	L375-01030		Gear case front cover gasket	1
5	15	L375-01015		Timing gear case cover	1
5	16	L375-01009		Timing gear case cover gasket	1
5	17	GB119-B8x18		Pin B8x18	1
5	18	L480Q-109000		Timing advance assembly	1

# Parts Breakdown - Engine

Fig 6 - Timing Gear & Camshaft Assembly

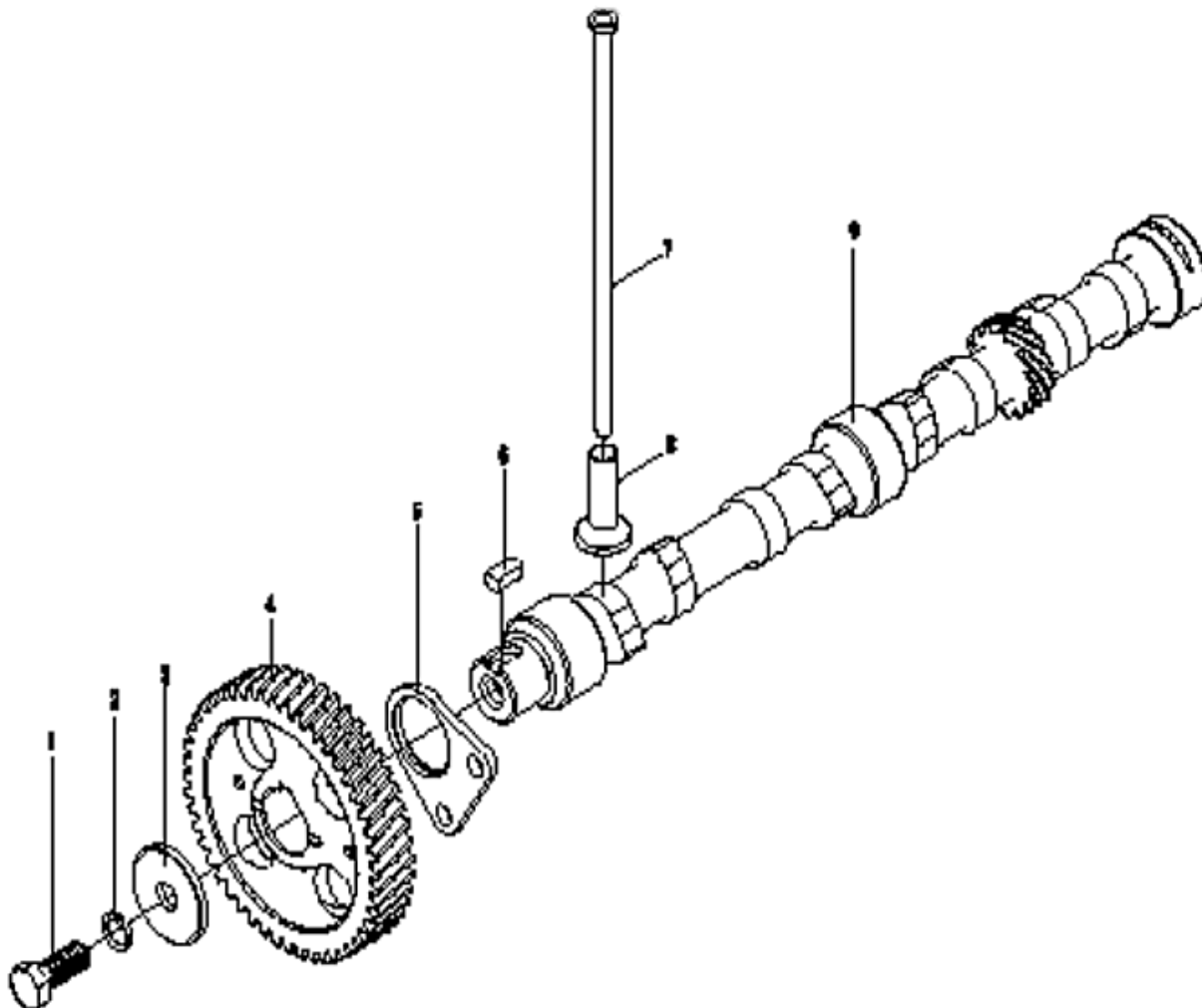

Fig#	Ref#	Mfg. Part#	NTE Part#	Description	Qty
6	1	GB5783-M12x35		Bolt M12x35	1
6	2	GB93-12		Washer 12	1
6	3	L375-02004	FCL37502004	Camshaft gear circlip	1
6	4	4L22BT-02011	FC4L22BT02011	Camshaft gear	1
6	5	L375-02002	FCL37502002	Camshaft thrust gasket	1
6	6	GB1096-79-C8x18		Key C8x18	1
6	7	4L22-02003	FC4L2202003	Valve push rod	8
6	8	L375-02005	FCL37502005	Valve tappet	8
6	9	4L22-02001	FC4L2202001	Camshaft	1

# Parts Breakdown - Engine

**Fig 7 - Cylinder Head Assembly**

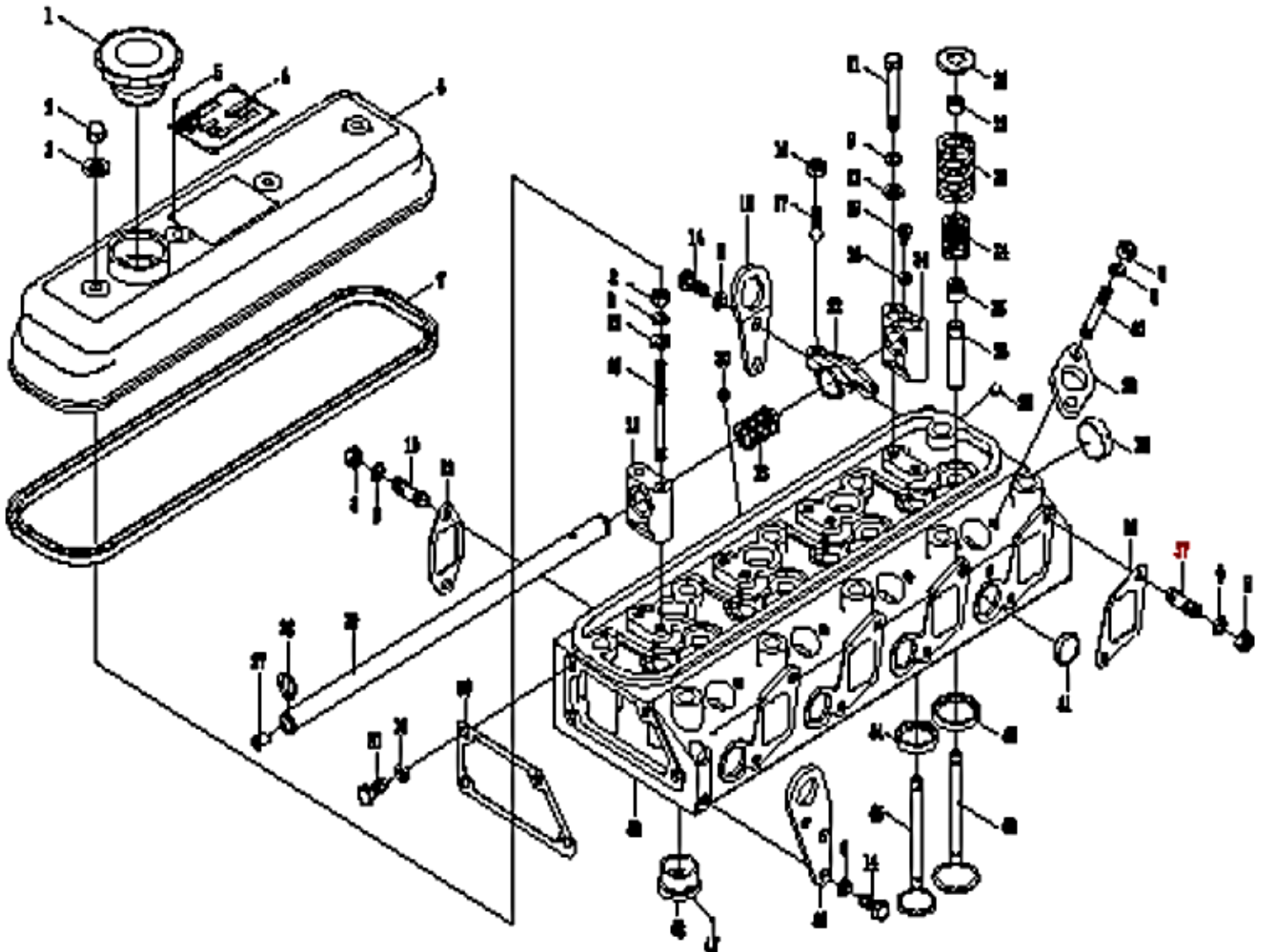

Fig#	Ref#	Mfg. Part#	NTE Part#	Description	Qty
7	1	L375-03005	FCL37503005	Filler cap	1
7	2	GB923-M8		Nut M8	4
7	3	L375-03017		Sealing washer	4
7	4	KM385TA-03302		Brand mark plate	1
7	5	GB827-2x6		Rivet 2x6	4
7	6	4L22T-03301	FC4L22T03301	Cylinder head cover	1
7	7	4L22-03002	FC4L2203002	Cylinder head cover gasket	1
7	8	GB6170-M8		Bolt M8	28
7	9	GB93-8		Washer 8	40
7	10	GB848-M8		Washer 8	28
7	11	LL480B-03001		Rocker arm seat fixed bolt	4
7	12	GB898-M8x30		Bolt M8x30	8

## Parts Breakdown - Engine

Fig#	Ref#	Mfg. Part#	NTE Part#	Description	Qty
7	13	4L22-03006	FC4L2203006	Exhaust pipe gasket	4
7	14	GB5781-M8x20		Bolt M8x20	4
7	15	L375-03012		Rear slinger	1
7	16	GB6170-M8X1		Bolt M8x1	8
7	17	LL480B-03201		Valve clearance adjusting screw	8
7	18	GB5782-M8x60		Bolt M8x60	4
7	19	L375-03206		Rocker shaft locating screw	1
7	20	GB898-6-100HV		Washer 6-100HV	16
7	21	4L22BT-03009	FC4L22BT03009	Valve spring seat(upper)	8
7	22	LL480B-03008	FCLL480B03008	Valve clamp	16
7	23	4L22-03015	FC4L2203015	Valve outer spring	8
7	24	L375-03007	FCL37503007	Valve inner spring	8
7	25	L375-03019		Valve oil seal	8
7	26	KM485QB-03102	FCKM485QB03102	Valve guide	8
7	27	L375-01115		Blind plug $\phi$ 10	2
7	28	GB894.1-86		Circlip	2
7	29	4L22-03205	FC4L2203200	Rockshaft	1
7	30	L375-03107		Blind plug $\phi$ 8.3	4
7	31	L375-03202		Rockshaft bracket	3
7	32	4L22-03210	FC4L2203210	Valve rocker arm	8
7	33	L375-03204		Valve rocker shaft spring	3
7	34	L375-03207		Rocker shaft rear arm	1
7	35	D495QB-03110		Stopper $\phi$ 6	1
7	36	D495QB-01024		Blind plug $\phi$ 32	1
7	37	GB898-M8x35		Bolt M8x25	8
7	38	195-03014		Injector hold-down	4
7	39	4L22-03013	FC4L2203013	Intake pipe gasket	4
7	40	GPB898-M8x65		Bolt M8x65	8
7	41	L375-03106	FCL37503106	Blind plug $\phi$ 25	6
7	42	4L22-03103	FC4L2203103	Intake valve seat	4
7	43	4L22-03005	FC4L2203005	Intake valve	4
7	44	4L22-03104	FC4L2203104	Exhaust valve seat	4
7	45	4L22-03004	FC4L2203004	Exhaust valve	4
7	46	LL480-03010		Front stationary rings	1
7	47	GB308-84		Steel ball $\phi$ 3	4
7	48	4L22T-03102	FC4L22T03102	Insert block	4
7	49	4L22-03101		Cylinder head	1
7	50	L375-03010	FCL37503010	Thermostat housing gasket	1
7	51	GB5781-M8x25		Bolt M8x25	4

# Parts Breakdown - Engine

**Fig 8 - Piston & Connecting Rod Assembly**

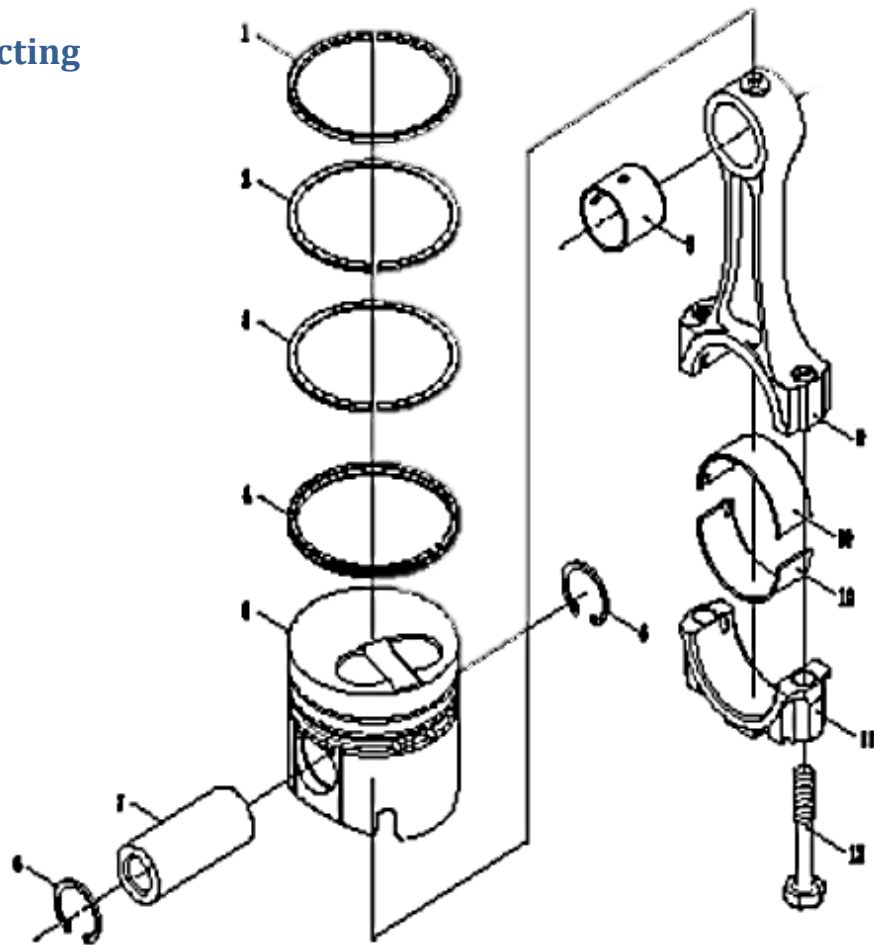

Fig#	Ref#	Mfg. Part#	NTE Part#	Description	Qty
8	1	4L22-04001	use FC4L22T04010	1st compression ring	1
8	2	4L22-04002	use FC4L22T04010	2nd compression ring	1
8	3	4L22-04100	use FC4L22T04010	Oil scraper ring	1
8	4	4L22-04005	FC4L2204005	Piston	1
8	5	GB893.1-26		Circlip 26	2
8	6	4L22-04004	FC4L2204004	Piston pin	1
8	7	4L22-04201	FC4L2204201	CONNECTING ROD BUSHING	1
8	8	4L22-04202	use FC4L2204200	Connecting rod	1
8	9	4L22-04003	FC4L2204003	CONNECTING ROD BEARING (U & L)	2
8	10	4L22-04203	use FC4L2204200	Connecting rod cover	1
8	11	4L22BZ-04204	use FC4L2204200	Connecting rod bolt	2

# Parts Breakdown - Engine

Fig 9 - Crankshaft & Flywheel Assembly

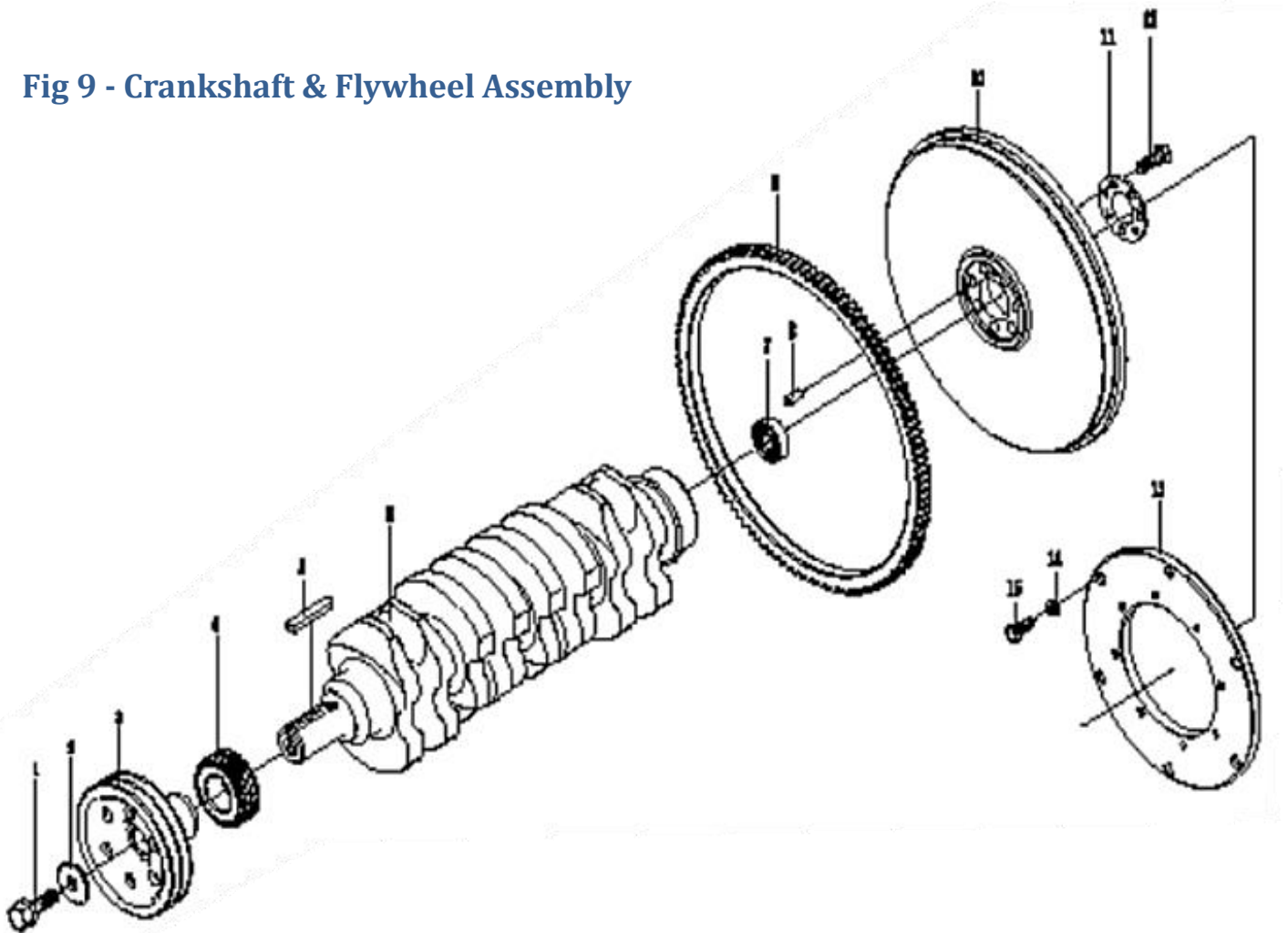

Fig#	Ref#	Mfg. Part#	NTE Part#	Description	Qty
9	1	4L22BT-05006	FC4L22BT05006	Starting claw	1
9	2	L375-05005	FCL37505005	Starting claw washer	1
9	3	4L22BT-05005	FC4L22BT05005	Crankshaft belt pulley	1
9	4	KM385T-05007	FCKM385T05007	Crankshaft timing gear	1
9	5	GB1096-79-C10x63		Key C10x63	1
9	6	4L22-05003	FC4L2205003	Crankshaft	1
9	7	GB276-6203-2RS	FCGBT27662032RS	Bearing 6203-2RS	
9	8	GB119-B8x20		Pin B8 x20	1
9	9	LL480-05102	FCLL48005102	Flywheel gear ring	1
9	10	4L22BT-05101-2		Flywheel	1
9	11	4L22-05002		Flywheel bolt backing	
9	12	4L22BT-05001-4		Flywheel bolt	1
9	13	LL380D-05103		Flywheel connect plate	1
9	14	GB93-8		Washer 8	6
9	15	GB5783-M8x25		Bolt M8x25	6

# Parts Breakdown - Engine

**Fig 10 - Cooling  
System Assembly**

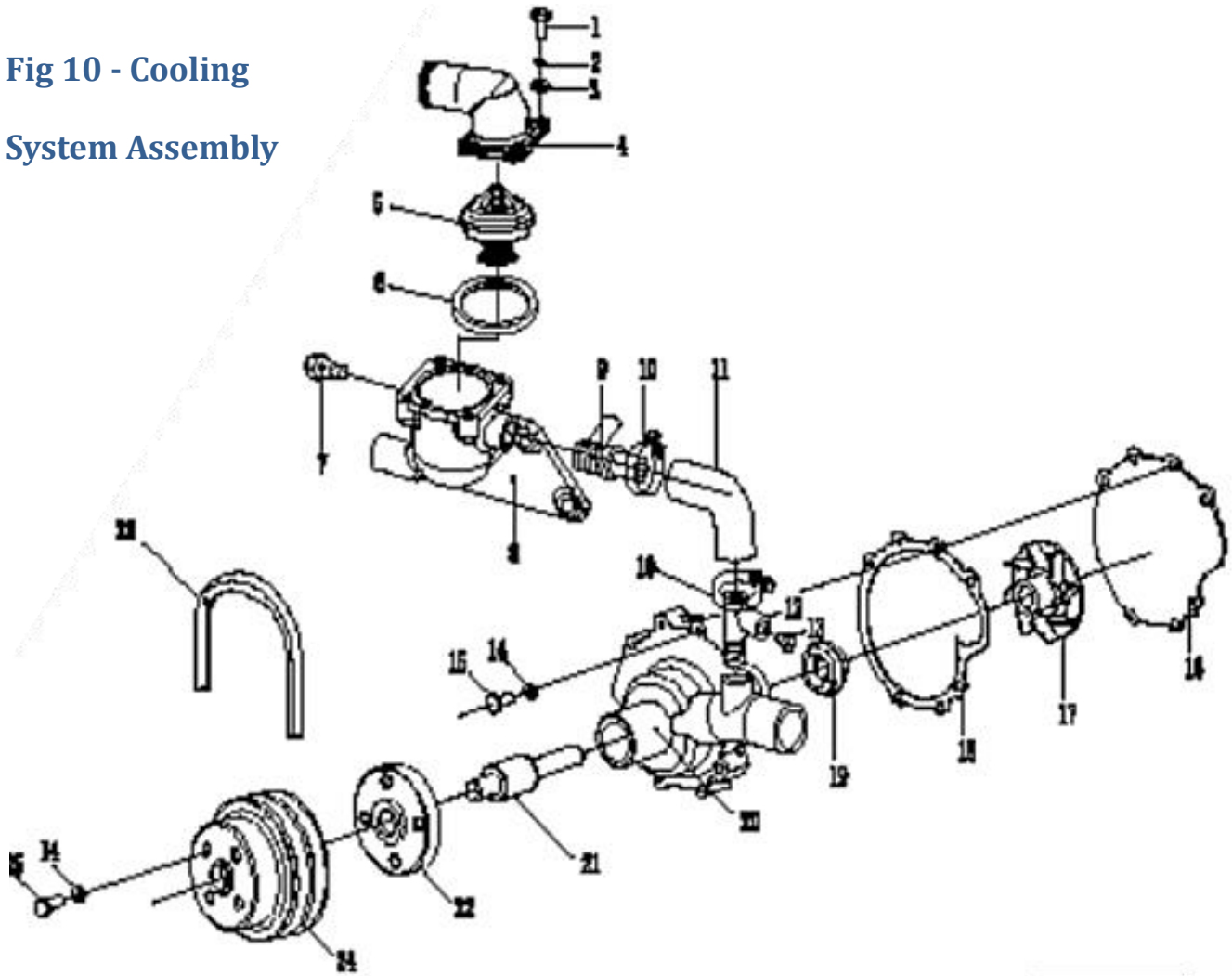

Fig#	Ref#	Mfg. Part#	NTE Part#	Description	Qty
10	1	GB5783-M6x22		Bolt M6x22	4
10	2	GB93-6		Washer 6	4
10	3	GB848-M6-140HV		Washer 6-140HV	4
10	4	LL380-06201	FCLL380062011	Thermostat cover	1
10	5	L375-06203	FCL37506203	Thermostat	1
10	6	KM385T-06209-1		Thermostat cover gasket	1
10	7	L375-06206	FCL37506206	Water temperature transmitter	1
10	8	L375-06204	FCL37506204	Thermostat housing	1
10	9	LL480-06303	use FC4L22BT06100	Small circulating water pipe	2
10	10	ZBT32005.1-88-26		Clamp 26	1
10	11	LL380-06001	FCLL38006001	Hose	1
10	12	4L22-06110		Water pipe	1
10	13	L375Y3-14-06111	use FC4L22BT06100	Stopper	6

# Parts Breakdown - Engine

Fig#	Ref#	Mfg. Part#	NTE Part#	Description	Qty
10	14	GB93-8		Washer 8	2
10	15	GB5783-M8x30		Bolt M8x30	1
10	16	4L22-06108	use FC4L22BT06100	Water pump rear cover	1
10	17	4L22-06105	use FC4L22BT06100	Water pump impeller	1
10	18	4L22-06107	use FC4L22BT06100	Water pump gasket	1
10	19	IIF-15	use FC4L22BT06100	Water seal	1
10	20	4L22BT-06103	use FC4L22BT06100	Water pump housing	1
10	21	LL480-06106	use FC4L22BT06100	Water pump bearing	1
10	22	LL480-06113	use FC4L22BT06100	Water pump hubcap	1
10	23	GB/T12732-1996-A-1000		Belt A-1000	1
10	24	4L22BT-06102		Belt pulley	1
10	25	GB5780-M8x25		Bolt M8x25	4

**Fig 11 - Intake  
Manifold Assembly**

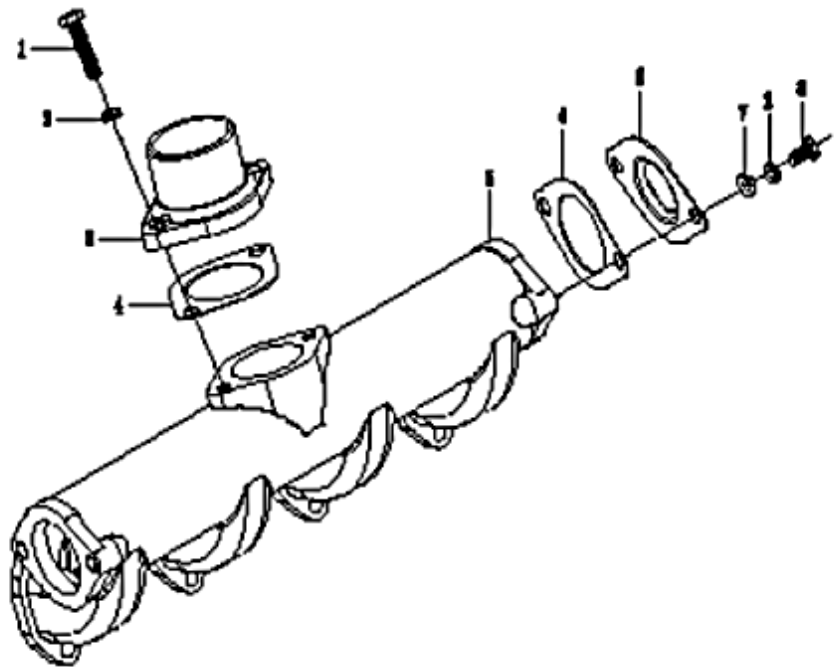

Fig#	Ref#	Mfg Part#	NTE Part#	Description	Qty
11	1	GB5783-M8x25		Bolt M8x25	2
11	2	GB93-8		Washer 8	6
11	3	LL380-07004		Intake manifold joint pipe	1
11	4	L375Y3-07003	FCL375Y307003	Intake manifold cover gasket	3
11	5	4L22T-07001-1	FC4L22T070011	Intake manifold	1
11	6	L375Y3-07002		Intake manifold cover	2
11	7	GB97.1-8		Washer 8	4
11	8	GB5783-M8x16		Bolt M8x16	4

# Parts Breakdown - Engine

**Fig 12 - Exhaust  
Manifold Assembly**

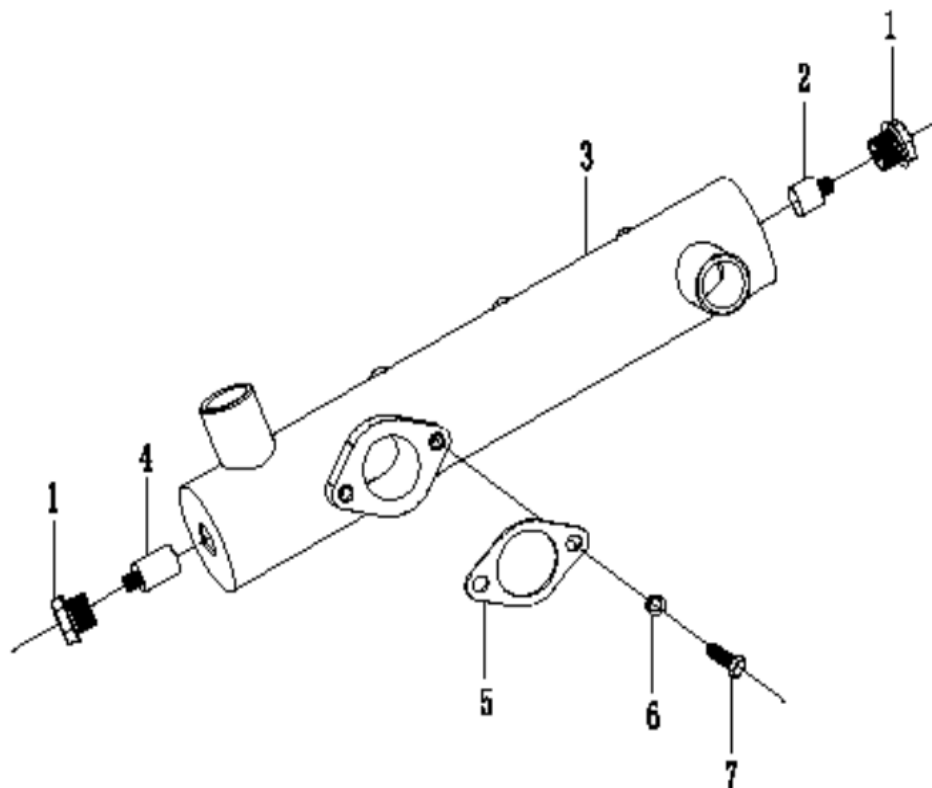

Fig#	Ref#	Mfg Part#	NTE Part#	Description	Qty
12	1	LL480-08003		Exhaust manifold plug	2
12	2	LL380D-08005		Exhaust manifold zinky stick I	1
12	3	4L22BT-08001-2	FC4L22BT080012	Exhaust manifold	1
12	4	LL380D-08005-1		Exhaust manifold zinky stick II	1
12	5	KM385T-08002	FCKM385T08002	Exhaust manifold gasket	1
12	6	GB93-10		Washer 10	2
12	7	GB5783-M10x30		Bolt M10x30	2
12		335A-0100020	FC335A0100020	Exhaust Extension, 2 BOLT (not shown)	1
12		LD485-0100020	FCLD4850100020	Exhaust Extension, 4 BOLT (not shown)	1

# Parts Breakdown - Engine

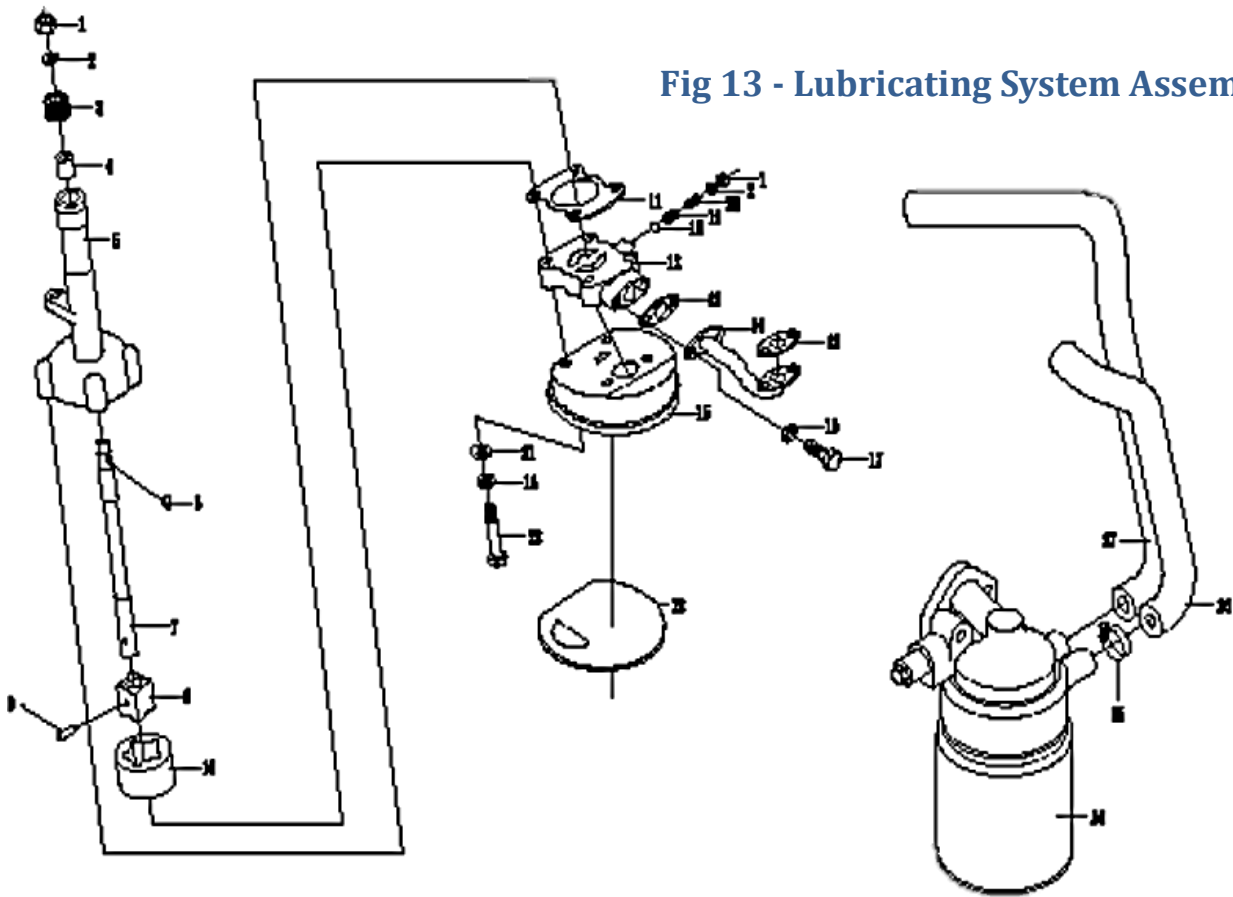

**Fig 13 - Lubricating System Assembly**

Fig#	Ref#	Mfg. Part#	NTE Part#	Description	Qty
13	1	GB6170-M10	use FC4L22091009	Nut M 10	2
13	2	GB93-10	use FC4L22091009	Washer 10	2
13	3	LL480-09107	use FC4L22091009	Oil pump driven gear	1
13	4	4L22-09121	use FC4L22091009	Oil pump body bush	1
13	5	4L22-09122	use FC4L22091009	Oil pump body	1
13	6	GB1099-79-3x5x13	use FC4L22091009	Woodruff key 3x5x13	1
13	7	4L22-09111	use FC4L22091009	Oil pump shaft	1
13	8	4L22-09112	use FC4L22091009	Inner rotor	1
13	9	LL480-09113	use FC4L22091009	Pin	1
13	10	4L22-09101	use FC4L22091009	Outer rotor	1
13	11	4L22-09105	use FC4L22091009	Oil pump gasket	1
13	12	4L22-09104	use FC4L22091009	Oil pump cover	1
13	13	4L22-09001	FC4L2209001	Oil outlet pipe flange gasket	2
13	14	4L22-09200	FC4L2209200	Oil outlet pipe unit	1
13	15	4L22-09103	use FC4L22091009	Gauze strainer	1
13	16	GB93-8-100HV	use FC4L22091009	Washer 8-100HV	6
13	17	GB5783-M8x20	use FC4L22091009	Bolt M8x20	2
13	18	GB308-77	use FC4L22091009	Steel ball	1

# Parts Breakdown - Engine

Fig#	Ref#	Mfg. Part#	NTE Part#	Description	Qty
13	19	LL480-09109	use FC4L22091009	Limit valve spring	1
13	20	1105-09207	use FC4L22091009	Adjusting pressure screw	1
13	21	GB97.1-8-100HV	use FC4L22091009	Washer 8-100HV	4
13	22	GB5782-M8x40	use FC4L22091009	Bolt M8x40	4
13	23	4L22-09130	use FC4L22091009	Weldment	1
13	24	4L22B-09300		Oil filter	1
13	24	4L22-09305	FC4L2209305	OIL FILTER (WB447)	1
13	24	4L22B-09320	FC4L22B09320	OIL FILTER SEAT	1
13	25	ZBT32005.1-88-24		Circle clamp	4
13	26	LL380BD-09401		Fuel cooler inlet pipe	1
13	27	LL480BD-09402		Fuel cooler outlet pipe	1
13	28	4L22-09100-1	FC4L22091001	Oil pump driven assembly	1

**Fig 14 - Fuel System Assembly**

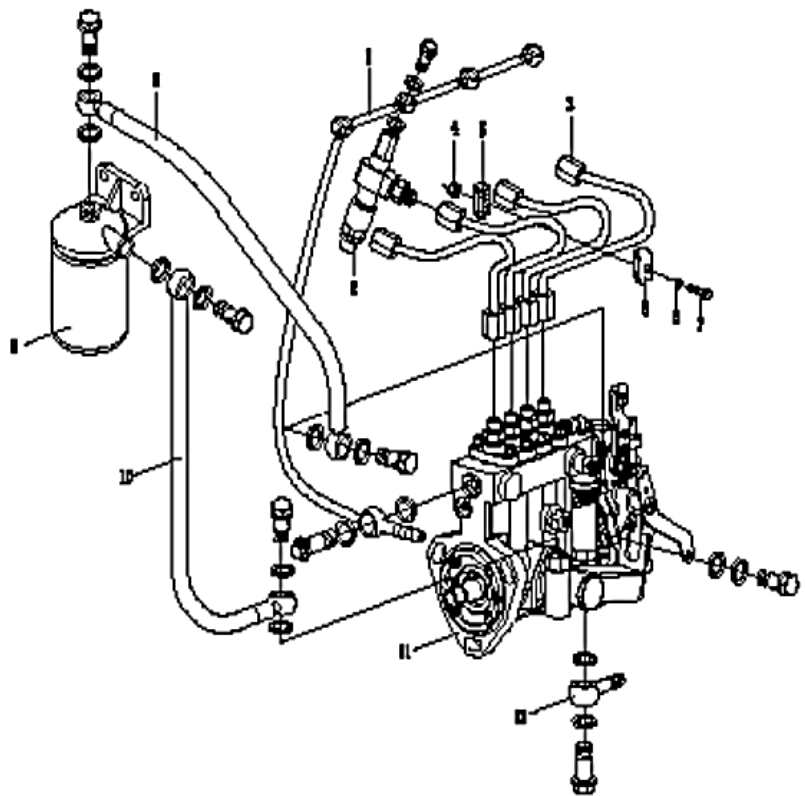

Fig#	Ref#	Mfg Part#	NTE Part#	Description	Qty
14	1	4L22BT-10400-3	FC4L22BT104003	Fuel return pipe	1
14	2	KM385TA-10300	FCKM385TA10300	Fuel injector	4
14	3	4L22-10200	FC4L2210200	Fuel injection pipe	1
14	4	GB/T6170-M6		Nut M6	2
14	5	D495QB-10600		Fuel injection pipe clamp	4

# Parts Breakdown - Engine

Fig#	Ref#	Mfg Part#	NTE Part#	Description	Qty
14	6	GB/T93-1987		Washer 6	2
14	7	GB65-85-6x30		Screw M6x30	2
14	8	L375-10600	FCL37510600	Pipe from filter to injection pump	1
14	9	L375-10500	FCL37510500-1	Fuel filter	1
14	10	L375-10700-1	FCL375107001	Fuel pipe from feed pump to filter	1
14	11	4Q213YC-1	FC4Q213YC1	Injection pump assy	1
14	12	L375-10601		Pipe joint	1

**Fig 15 - Engine Electrical Components**

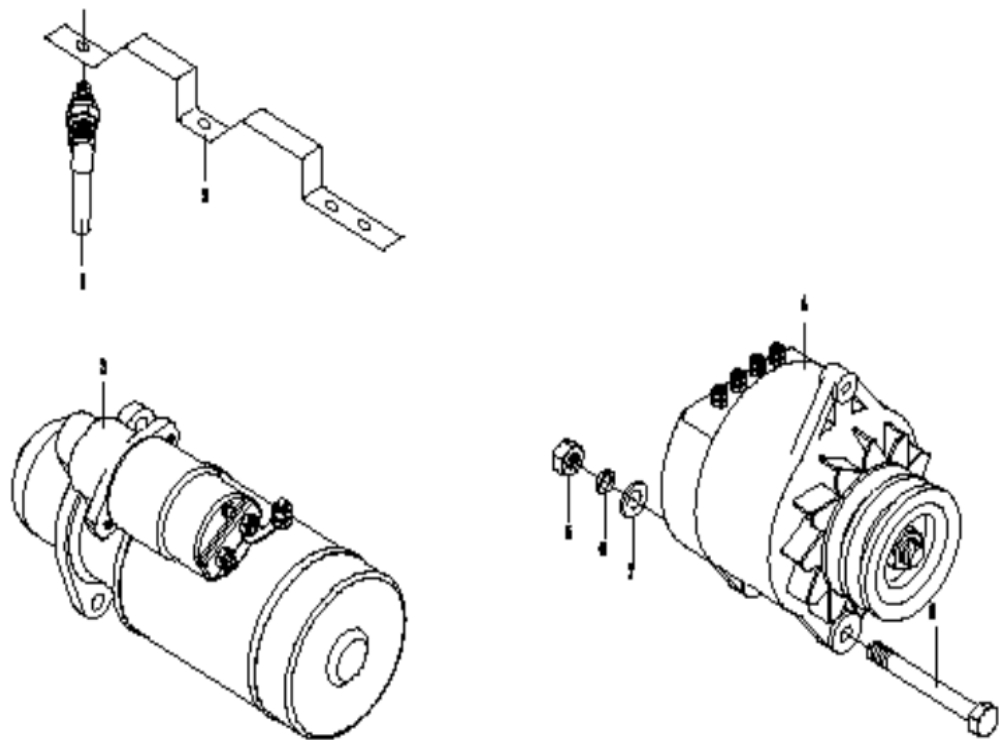

Fig#	Ref#	Mfg. Part#	NTE Part#	Description	Qty
15	1	L375-12200-1	FCL375122001	Electric preheat plug	4
15	2	LL480-12002		Current conducting plate	1
15	3	4L22BT-12300J-1	FC4L22BT12300J1	Starting motor unit	1
15	4	L375-12100	FCL37512100	Alternator	1
15	5	GB6170-M10		Nut M10	1
15	6	GB93.1-10		Washer 10	1
15	7	GB848-M10-100HV		Washer 10-100HV	1
15	8	GB5781-M10x120		Bolt M10x120	1