

OPERATING INSTRUCTIONS MANUAL

(Please retain for future reference)

For

FVO-200 INDIRECT FIRED SPACE HEATERS



CERTIFIED FOR USE IN CANADA AND U.S.A.

**As per CSA B140.8 Portable Oil Fired Heaters / CSA B140.02003 Oil Burning Equipment
Construction Heaters Unattended Type.**



**FLAGRO INDUSTRIES LIMITED
ST. CATHARINES, ONTARIO
CANADA**

GENERAL HAZARD WARNING:

FAILURE TO COMPLY WITH THE PRECAUTIONS AND INSTRUCTIONS PROVIDED WITH THIS HEATER, CAN RESULT IN DEATH, SERIOUS BODILY INJURY AND PROPERTY LOSS OR DAMAGE FROM HAZARDS OF FIRE, EXPLOSION, BURN, ASPHYXIATION, CARBON MONOXIDE POISONING, AND/OR ELECTRICAL SHOCK.

ONLY PERSONS WHO CAN UNDERSTAND AND FOLLOW THE INSTRUCTIONS SHOULD USE OR SERVICE THIS HEATER.

IF YOU NEED ASSISTANCE OR HEATER INFORMATION SUCH AS AN INSTRUCTIONS MANUAL, LABELS, ETC. CONTACT THE MANUFACTURER.

WARNING:

FIRE, BURN, INHALATION, AND EXPLOSION HAZARD. KEEP SOLID COMBUSTIBLES, SUCH AS BUILDING MATERIALS, PAPER OR CARDBOARD, A SAFE DISTANCE AWAY FROM THE HEATER AS RECOMMENDED BY THE INSTRUCTIONS. NEVER USE THE HEATER IN SPACES WHICH DO OR MAY CONTAIN VOLATILE OR AIRBORNE COMBUSTIBLES, OR PRODUCTS SUCH AS GASOLINE, SOLVENTS, PAINT THINNER, DUST PARTICLES OR UNKNOWN CHEMICALS.

WARNING:

NOT FOR HOME OR RECREATIONAL VEHICLE USE.

WARNING:

INTENDED USE IS PRIMARILY THE TEMPORARY HEATING OF BUILDINGS UNDER CONSTRUCTION, ALTERATION, REPAIR OR EMERGENCIES ONLY.

ALWAYS PROVIDE ADEQUATE VENTILATION. 1 SQ. IN. OF FRESH AIR MUST BE SUPPLIED FOR EVERY 1000 BTUH OF HEAT.

THIS HEATER SHALL BE INSTALLED SUCH THAT IT IS NOT DIRECTLY EXPOSED TO WATER SPRAY, AND/OR DRIPPING WATER.

This heater is designed and approved for use as a construction heater under CSA B140.8 Portable Oil Fired Heaters / CSA B140.02003 Oil Burning Equipment.

We cannot anticipate every use which may be made of our heaters. CHECK WITH YOU LOCAL FIRE SAFETY AUTHORITY IF YOU HAVE QUESTIONS ABOUT APPLICATIONS.

Other standards govern the use of fuel gases and heat producing products in specific applications. Your local authority can advise you about these.

SPECIFICATIONS

Model	FVO-200
Input	200,000 btuh
Fuel	No.1, No. 2, diesel or kerosene
Fuel Pressure	145 psi
Nozzle	1.25 x 60B (Delavan)
Ignition	Direct Spark Ignition
.....	Thermostat Control
Air Circulation	1500 cfm
Fuel Consumption	1.50 Gal/hr
Approved	cETLus listed
Weight	330 lbs (Tank empty) 490 lbs (Tank Full)

INSTALLATION:

The installation of this heater for use with No.1, No.2, Diesel or Kerosene and shall conform with local codes or, in the absence of codes, with the National Fuel Gas Code ANSI Z223.1/NFPA 54. For recommended installation practices refer to CSA Standard B139.

CLEARANCE TO COMBUSTIBLES:

<u>TOP</u>	<u>FRONT</u>	<u>SIDES</u>	<u>REAR</u>	<u>FLUE PIPE</u>
3 ft	10 ft	1 ft	2 ft	3 ft

FUEL:

This heater will operate with No.1, No.2, Diesel or Kerosene.
Note: No.1 Fuel Oil or Kerosene must be used for temperatures less than -10°C (8°F).

ELECTRICAL:

WARNING Electrical Grounding Instructions

This appliance is equipped with a three-prong (grounding) plug for your protection against shock hazard and should be plugged directly into a properly grounded three-prong receptacle.

115v supply must be available. Please note that the heater requires 15 amps for proper operation. Ensure appropriate gauge extension cord is used.

- 12/3 AWG at 50 Feet
- 10/3 AWG at 100 Feet

FV SERIES CONSTRUCTION HEATER – VENTING REQUIREMENTS

1. VERTICAL FLUE TERMINATIONS

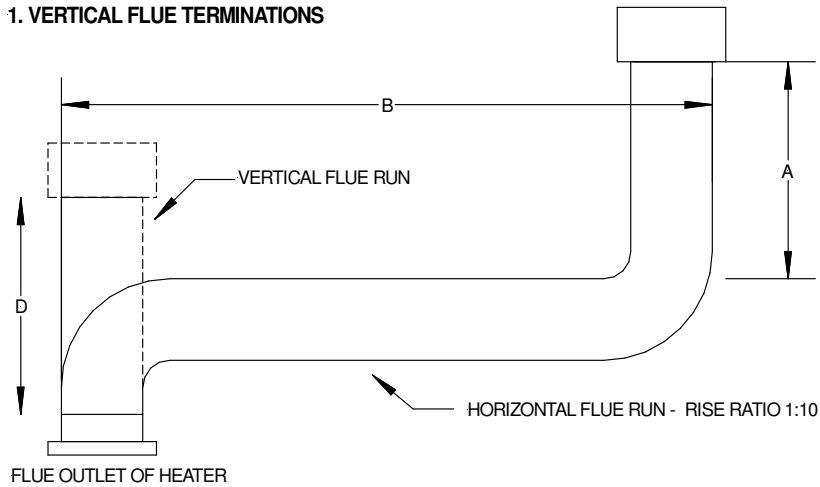

2. HORIZONTAL FLUE TERMINATIONS

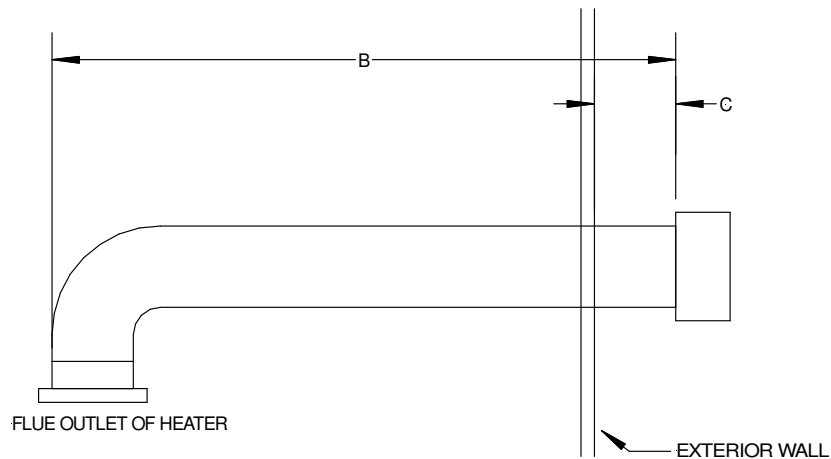

- A - VENT TERMINATION MUST BE A MINIMUM OF 2FT HIGHER THAN ANY POINT WITHIN 10FT.
- B - MAXIMUM HORIZONTAL RUN IS 30FT.
NOTE: 90deg ELBOW = 10ft HORIZONTAL VENT ALLOWANCE
45deg ELBOW = 5ft HORIZONTAL VENT ALLOWANCE
- C - VENT TERMINATION IN HORIZONTAL POSITION MUST BE MINIMUM 4ft FROM ANY COMBUSTABLE SURFACE
- D - EXTERIOR VERTICAL VENT TERMINATION MUST BE A MINIMUM OF 2ft.

NOTE: ALL VENT TERMINATIONS MUST HAVE A RAIN CAP INSTALLED AS PER LOCAL CODE REQUIREMENTS.

MAINTENANCE:

1. **Every construction heater should be inspected before each use, and at least annually by a qualified service person. Incorrect maintenance may result in improper operation of the heater and serious injury could occur.**
2. The hose assemblies shall be visually inspected prior to each use of the heater. If it is evident there is excessive abrasion or wear, or the hose is cut, it must be replaced prior to the heater being put into operation. The replacement hose assembly shall be that specified by the manufacturer.
3. The flow of combustion and ventilation air must not be obstructed. Be sure to check the fan assembly and ensure that the motor and blade are operating properly.
4. Compressed air should be used to keep components free of dust and dirt build up. Note: Do not use the compressed air inside any piping or regulator components.
5. Change fuel filter insert (Part# FVO-418) once per month. Change fuel filter cartridge (Part# FVO-419) once every 6 months.
6. Change oil nozzle (Part# FV-235) once per year.
7. Fan Limit Switch (Part# FV-407A) should be replaced if the fan motor does not shut off after the heat exchanger has cooled down.
8. The High Limit Switches (Part# FV-206 & FV-437) should be checked each season. These limit switches will ensure the burner shuts down if the temperature exceeds 250° F at the outlet.
9. Fuel tank should be drained on a regular basis by removing drain plug.
10. **CAUTION** – Do not have any source of ignition near the heater when draining tank.

NOTE: No.1 fuel oil or kerosene is recommended for temperatures below -10° C / 8° F.
11. Heat Exchanger should be cleaned if smokey conditions continue even after the air adjustments on the burner are made.

START UP INSTRUCTIONS:

1. Be sure the switch in is the “OFF” position.
2. Ensure electrical cord is grounded and heater is on a level surface.
3. Plug in supply cord to 115V 15amp outlet.
4. Make sure Smart Indicator Light is green, if not green, please refer to the “Power Supply Indicator Label” before proceeding with start up.
5. Move switch to “MANUAL” position for manual control.
6. Move switch to “THERMOSTAT” position for thermostatic control.

Please Note:

1. If using Thermostat on unit, unit must be started in Thermostat position.
2. When changing between manual and thermostat operation, the heater must be left in the “OFF” position for 30 seconds to prevent the burner from locking out.
3. When using a generator for electrical supply, make sure the generator is properly grounded and generator is at a 60Hz frequency.
4. In the event that a Generator is being used and the generator runs out of fuel, make sure the heater switch is in the “OFF” position before restarting generator, failure to do so may damage heater.

TO SHUT DOWN:

1. Move switch to “OFF” position.

NOTE: Fan will continue to operate after the burner shuts down. Once the unit cools down, the fan will stop.

IF HEATER FAILS TO START:

1. Press manual reset button at rear of burner.
2. Check fuel level. There must be 2-4 gallons of fuel in the tank for the heater to start properly.
3. Make sure there are no air locks in fuel lines or filter.
4. Ensure proper power supply and extension cord is being used.
5. Check for dirty fuel filter or blocked fuel supply line.
6. Check burner nozzle assembly.

NOTE: IF THE BURNER HAS BEEN RESET SEVERAL TIMES THERE MAY BE AN ACCUMULATION OF OIL IN THE CHAMBER! DO NOT CONTINUE TO TRY AND START THE HEATER!

DRAIN OIL FROM HEAT EXCHANGER USING DRAIN HOLE AT FRONT OF HEAT EXCHANGER FOR 15-20 MINUTES BEFORE ATTEMPTING TO RELIGHT. LET REMAINING EXCESS OIL BURN OFF BEFORE CHECKING COMBUSTION OF UNIT.

SAFE OPERATION PRECAUTIONS:

1. Do not fill fuel tank while heater is operation.
2. Do not attempt to start heater if excess oil remains in the heat exchanger.
3. Use switch to shut down the heater. Do not try to shut down the heater by unplugging the electrical cord.
4. Do not plug anything other than the thermostat into the "Thermostat" plug.
5. Do not use any fuel other than those listed on rating plate.
6. Follow electrical requirements shown on rating plate and/or Electrical requirements section of this manual.
7. Before removing any guards or performing any maintenance, be sure that the main power supply is disconnected.

COMBUSTION AIR ADJUSTMENTS:

NOTE: Proper combustion air adjustment must be achieved using a certified combustion analyzer and smoke tester to ensure complete combustion.

The air adjustment should be made to achieve 10% CO₂ and No. 1 or "trace" smoke. (Bacharach Scale)

SETTING THE AIR ADJUSTMENT PLATE

A) Regulation of the combustion air flow is made by adjustment of the manual AIR ADJUSTMENT PLATE (1) after loosening the FIXING SCREWS (2 & 3). The initial setting of the air adjustment plate should be made according to Column 5 in the Burner Set-up Chart.

B) The proper number on the manual AIR ADJUSTMENT PLATE (1) should line up with the SETTING INDICATOR (4) on the fan housing cover. Once set, the air adjustment plate should be secured in place by tightening SCREWS 2 and 3.

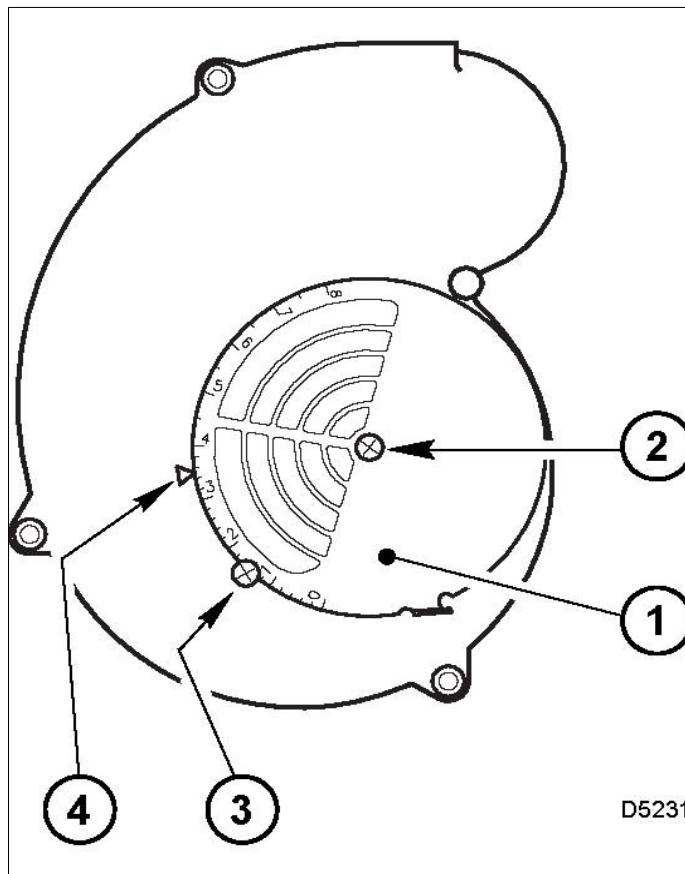

C) The final position of the air adjustment plate will vary on each installation. Use instruments to establish the proper settings for maximum CO₂ and a smoke reading of zero.

NOTE: Variations in flue gas, smoke, CO₂ and temperature readings may be experienced when the burner cover is put in place. Therefore, the burner cover **must** be in place when making the final combustion instrument readings, to ensure proper test results.

BURNER SET-UP CHART

1	2	3		4	5
ACTUAL FIRING RATE ± 5%	NOZZLE SIZE	PUMP PRESSURE		TURBULATOR SETTING	AIR DAMPER SETTING
GPH	GPH	PSI	BAR		
1.50	1.25 x 60°	145	10	4	4.5

- Note – Air damper setting is typically set at 4.50 for operation in colder temperatures. A combustion analyzer should always be used when setting the the burner.

TEMPERATURE FEELER GAUGE ADJUSTMENT (ATTACHED TO FAN SWITCH)

The temperature feeler gauge is required to be always touching the heater exchanger.

The temperature feeler gauge controls the air flow over the fan switch, which eliminates any unnecessary fan cycling. The temperature feeler gauge can be adjusted for different outside temperatures, by rotating the location of the temperature feeler gauge holes. This will provide maximum performance of the unit in different applications.

If supply air is warm (-5° C, indoor application):

Turn the temperature feeler gauge so that the holes are parallel with the heat exchanger. This will help the fan switch to remain cool and not overheat. See following:

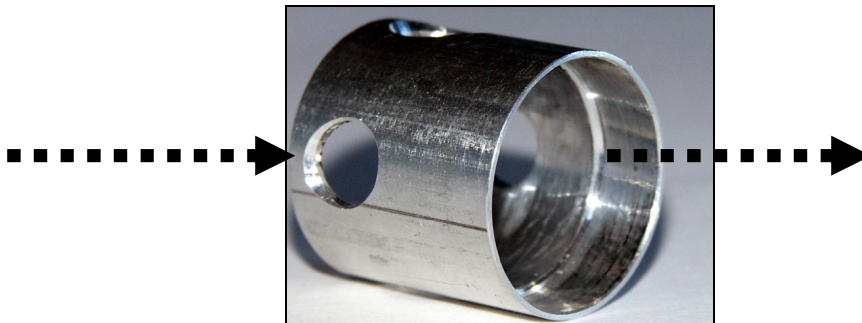

If supply air is cold (under -5°C):

Turn the temperature feeler gauge so that the holes are closed off as the air goes over the heat exchanger. This will reduce fan cycling and the unit from shutting down. See following:

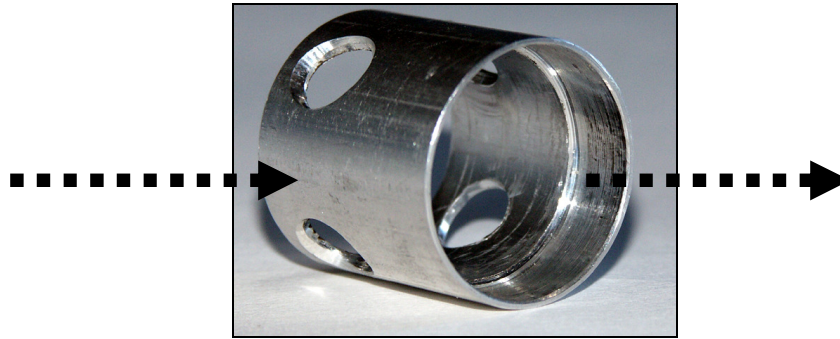

In extreme cold conditions, cover the holes on the temperature feeler gauge using foil tape or replace feeler gauge with part# FV-433B Solid feeler gauge. Ensure that the temperature feeler gauge is readjusted for warmer weather conditions. Failure to do so may result in burning out fan switches- not covered under warranty.

ELECTRICAL CONNECTIONS

It is advisable to leave the control box off the sub-base while completing the electrical connection to the burner.

- 1) Wire access hole (Use BX electrical connector)
- 2) Earth ground conductor terminal (Green wire)
- 3) Hot conductor terminal (Black wire)
- 4) Neutral conductor terminal (White wire)
- 5) Strain relief clamp

WARNING: The hot (black) wire must be connected to the L terminal and the neutral (white) wire must be connected to the N terminal or the primary safety control will be damaged. Do not connect wither wire to the terminal marked 

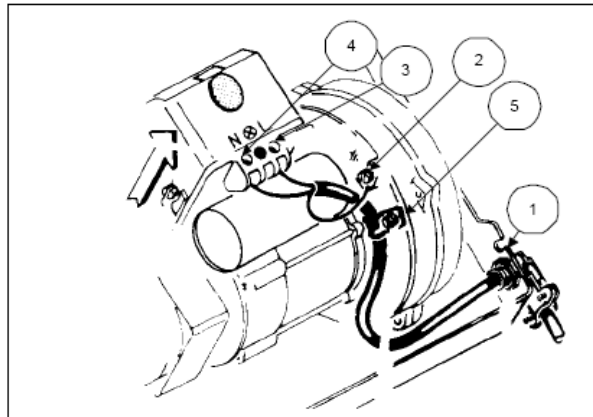

The burner may be controlled using either a DIRECT LINE VOLTAGE control circuit (120V AC 60 cycle) OR a LOW VOLTAGE control switching relay.

Using the appropriate diagram below, make electrical connections to burner. All wiring must be done in accordance with existing electrical codes, both national and local. When all electrical connections have been made, the control box may be put back in place on the sub-base.

WARNING: DO NOT activate burner until proper oil line connections have been made, or failure of the pump shaft seal may occur.

APPLICATION FIELD WIRING

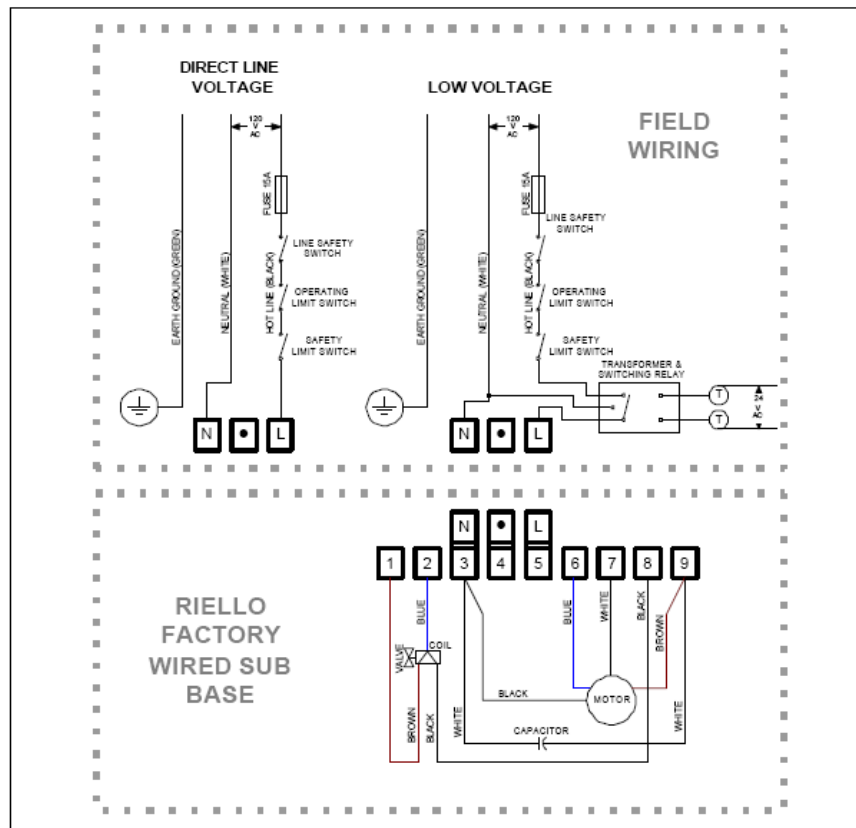

REMOTE SENSING OF SAFETY LOCKOUT: The SAFETY SWITCH in the 530SE CONTROL BOX is equipped with a contact allowing remote sensing of burner lockout. The electrical connection is made at terminal 4 (•) on the SUB-BASE. Should lockout occur the 530SE CONTROL BOX will supply a power source of 120Vac to the connection terminal. The maximum allowable current draw on this terminal (4) is 1 Amp.

WARNING: If a neutral or ground lead is attached to this terminal, the CONTROL BOX on the burner will be damaged should lockout occur.

INSERTION / REMOVAL OF DRAWER ASSEMBLY

- A)** To remove drawer assembly, loosen SCREW (3), then unplug CONTROL BOX (1) by carefully pulling it back and then up.
- B)** Remove the AIR TUBE COVER PLATE (5) by loosening the two retaining SCREWS (4).
- C)** Loosen SCREW (2), and then slide the complete drawer assembly out of the combustion head as shown.
- D)** To insert drawer assembly, reverse the procedure in items A to C above, and then attach fuel line to the pump.

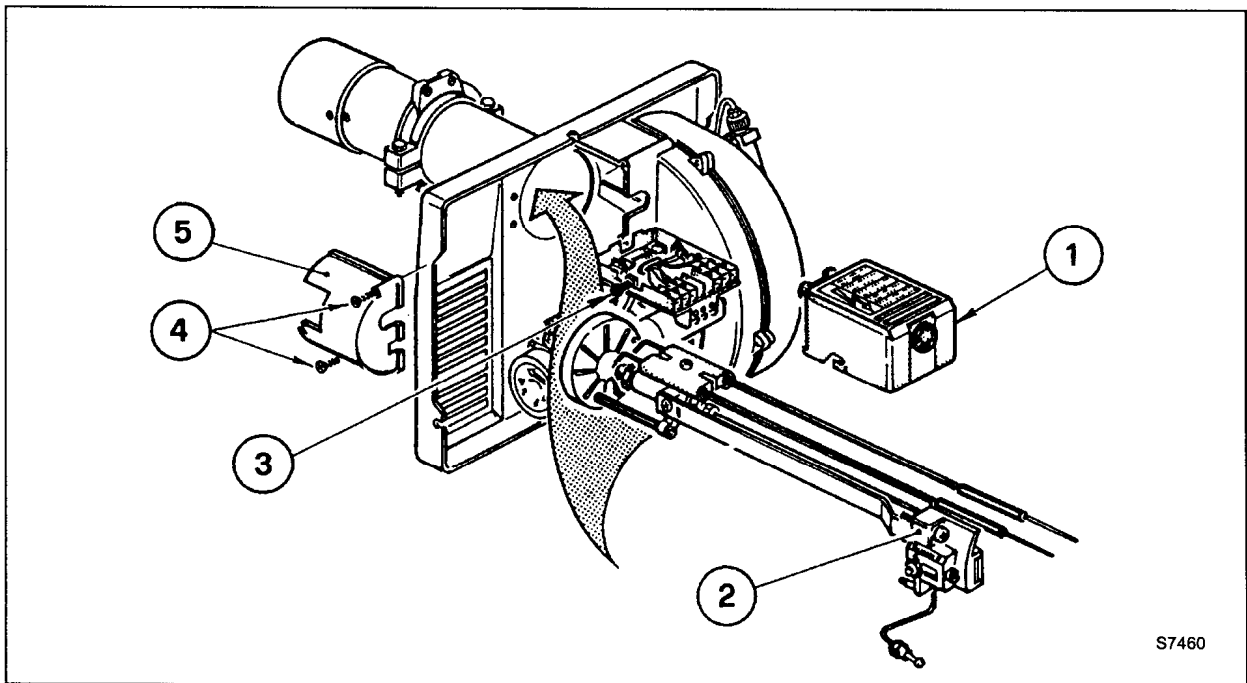

NOZZLE PLACEMENT

- A) Remove the NOZZLE ADAPTER (2) from the DRAWER ASSEMBLY by loosening the SCREW (1).

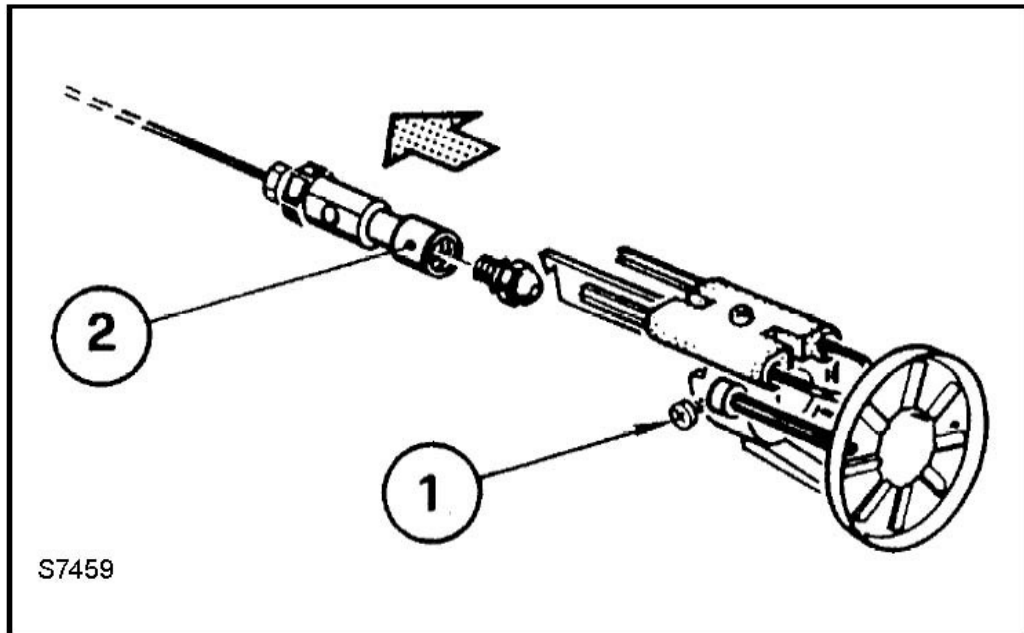

- B) Insert the proper NOZZLE into the NOZZLE ADAPTER and tighten securely (Do not over tighten).
- C) Replace adapter, with nozzle installed, into drawer assembly and secure with screw (1).

ELECTRODE SETTING

IMPORTANT: THIS DIMENSIONS MUST BE OBSERVED AND VERIFIED.

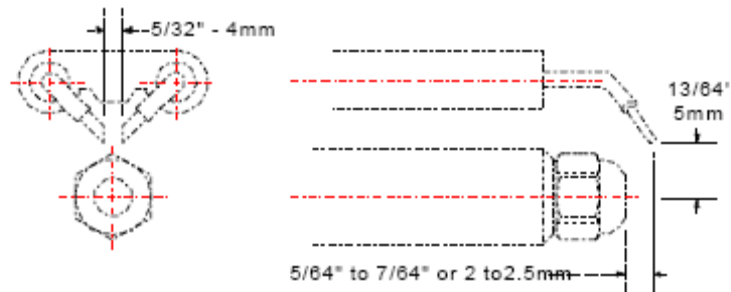

TURBULATOR SETTING

- A) Loosen NUT (1), then turn SCREW (2) until the INDEX MARKER (3) is aligned with the correct index number as per the Burner Set-up chart.
- B) Retighten the RETAINING NUT (1)

NOTE: Zero and five are scale indicators only. From left to right, the first line is 5 and the last line 0.

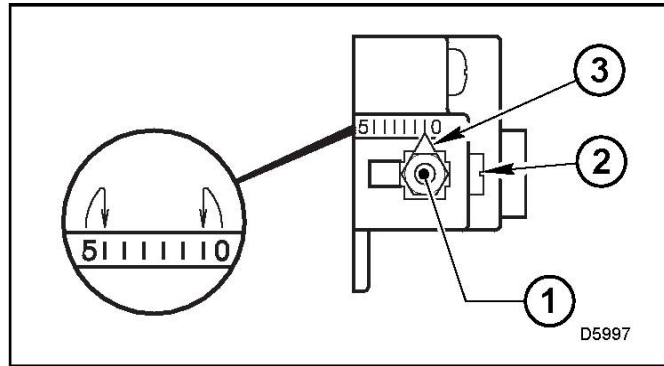

OIL LINE CONNECTIONS

Note: Pump pressure must be set at time of burner start-up. A pressure gauge is attached to the PRESSURE PORT (8) for pressure readings. Two PIPE CONNECTORS (5) are supplied with the burner for connection to either a single or a two-pipe system. Also supplied are two ADAPTORS (3), two female 1/4" NPT, to adapt oil lines to burner pipe connectors. All pump port threads are British Parallel Thread design. Direct connection of NPT threads to the pump will damage the pump body. Riello manometers and vacuum gauges do not require any adaptors, and can be safely connected to the pump ports. An NPT (metric) adapter must be used when connecting other gauge models.

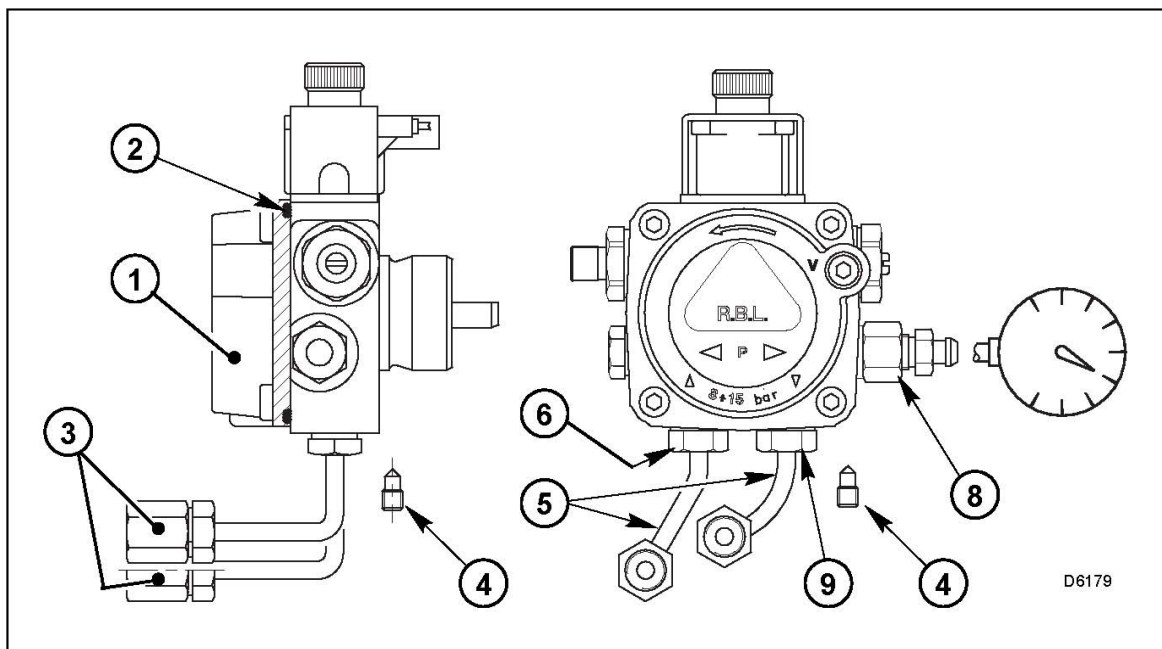

POWER SUPPLY INDICATOR LIGHT

Control Box



- * The power supply indicator light will help you detect any faulty power supplied to the heater.
- * The power supply indicator light will detect various power supply issues, such as: grounding issues or reverse Polarity or missing connections

Warning Light Indications

The smart indicator can detect and display the following fault conditions:

- | | | |
|---------------------------|---|---------------------------------|
| <u>Green Light</u> | ➔ | <u>Meets Power Requirements</u> |
| <u>Solid Red Light</u> | ➔ | <u>Reverse Polarity</u> |
| <u>Flashing Red Light</u> | ➔ | <u>Ground or Neutral issue</u> |

**** ATTENTION****

IF RED LIGHT IS INDICATED, MAKE CORRECTIONS TO POWER SUPPLY BEFORE TURNING HEATER ON. FAILURE TO DO SO, WILL VOID ANY WARRANTY

FV-200 SERIES - WIRING SCHEMATIC

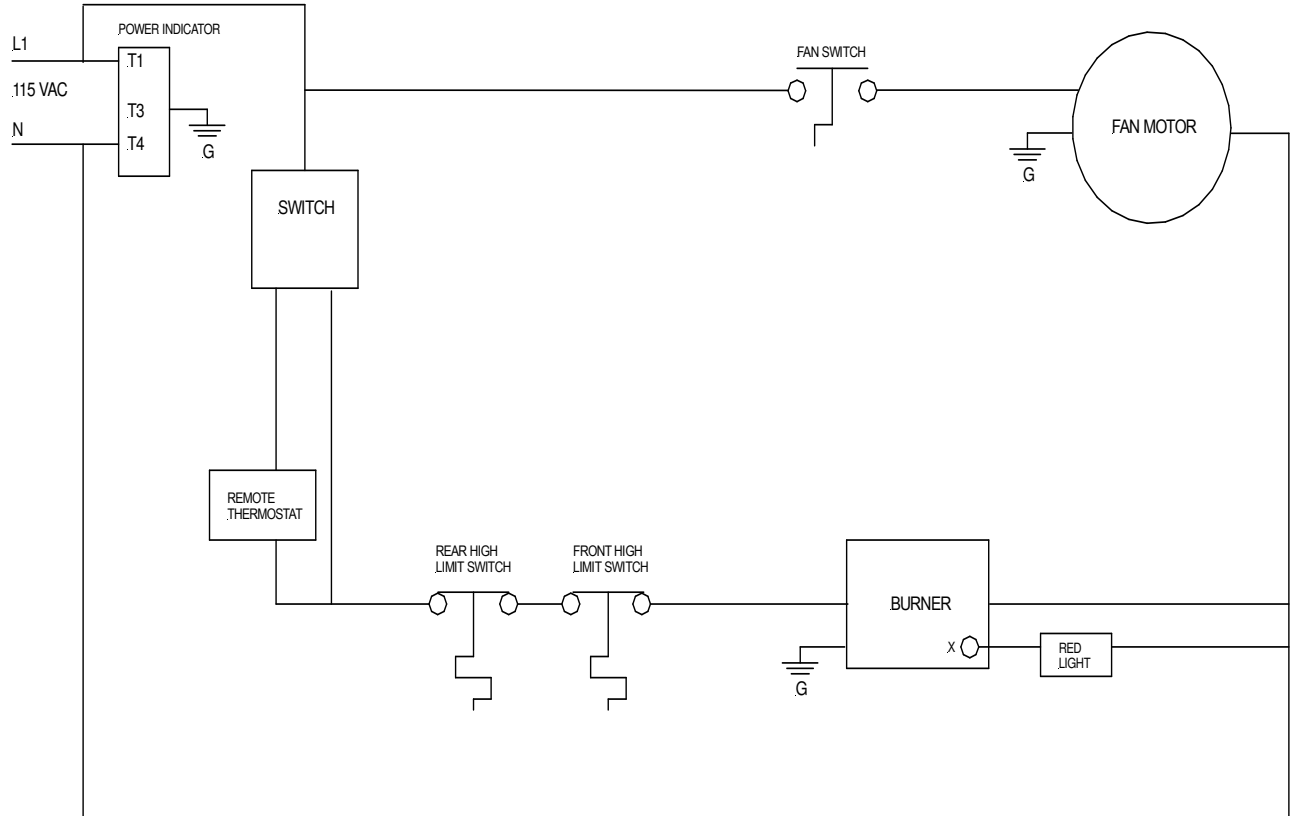

PARTS PRICE LIST 2009/2010

FVO-200 OIL INDIRECT FIRED HEATERS

PART NUMBER	DESCRIPTION
FV-201	1/2 HP Fan Motor
FV-202	15" Fan Blade
FV-203	12" Wheel
FV-204	12" Power Cord
FV-205	SS Heat Exchanger
40-113-D3.5GALV	½" X 3.5" Galvanized Nipple
40-108-8GALV	½" Galvanized Cap
FV-206	High Limit Switch (Outlet) 250F
FV-407A	Fan Limit Switch (Adjustable)
FV-207	Lockable Caster Wheel
FV-208	Fan Motor Canopy
FV-409	Toggle Switch (on control box)
FV-411	Red Light (on control box)
FV-214A	Thermostat Plug (on control box)
FV-215	Female Connector for FV-THA
FVO-215	Riello F5 Burner (Oil)
FVO-216	23 US Gallon Oil Tank (Steel)
FVO-216G	Fuel gauge
FVO-417	Oil Tank Cap
121-B	Oil Tank Drain Plug
FVO-418	Fuel Filter (Complete)
FVO-419	Fuel Filter (Insert Only)
FVO-220	Clear Fuel Line 6" (Tank to Filter)
FVO-221	Clear Fuel Line 7.5" (Filter to Burner)
FVO-222	Clear Fuel Return Line (Burner to Tank)
48-6C	Brass Fitting (Inlet Side of Filter)
2103-C-CGA	3/8" Shut Off Valve
122-C	3/8" Brass Hex Nipple
50-6C	3/8" FP x 3/8" MP Brass Elbow
49-6C	3/8" MP x 3/8" F.FL Brass Elbow
49-6B	1/4" MP x 3/8" F.FL Brass Elbow
FVO-223	7" Copper Pickup Tube c/w Adapter
FV-231	Burner Gasket

FV-433	Feeler Gauge
FV-433B	Feeler Gauge-Solid
FV-234	Front Face Plate (1 X 12")
FV-235	Oil Burner Nozzle (1.25 x 60B)
FV-437	High Limit (Rear) 150F
FV-240	Wheel Axle- FV-200 Series
FV-446	Sight Glass c/w Fiber Gasket
FV-447	Sight Glass Washer
FV-449SI	Smart Indicator Light
FVO-3000443	Pump Drive Key
FVO-3002278	Sub Base for F10/F5 Burner
FVO-3002279	Coil- F10/F5 Burner
FVO-3002280	Photo Cell- F10/F5 Burner
FVO-3005844	Capacitor F10/F5 Burner
FVO-3005855	Mounting Flange for F10/F5 Burner
FVO-3005869	Electrode Porcelain
FVO-3005880	Electrode Assembly
FVO-3006553	Coil U-Bracket c/w Knurled Nut
FVO-3006965	Nozzle Adapter F10/F5 Burner
FVO-3006966	Electrode Support for F10/F5 Burner
FVO-3006974	Nozzle Oil Tube F5 Burner
FVO-3006977	Turbulator Disc for F5 Burner
FVO-3006992	Pipe Connector-Supply
FVO-3006993	Pipe Connector-Return
FVO-3007320	Acoustic Liner for Burner Back Cover (F5)
FVO-3007233	Burner Back Cover F5 Burner
FVO-3007568	Bleeder Screw for F10/F5 Burner
FVO-3007802	Pump- F5 Burner
FVO-3008631	Electrode Assembly
FVO-C700-1029	Ignition Module (Oil Burner)
FVO-3005843	Motor- F5 Burner

ACCESSORIES	
FV-D12	12" x 12FT Canvas Ducting
FV-THA	Thermostat c/w 25FT Cord
FV-VK	6" x 3FT C-Vent c/w Rain Cap
FVO-C7001001	Emergency Service Kit (Oil Burner)
FVO-C7050010	Vacuum & Pressure Tester Manifold
FV-432	Pressure Gauge Adapter