

# PH2100PRi Digital Inverter Generator Operating Instructions



## **OPERATING INSTRUCTIONS**

PLEASE READ THIS MANUAL  
CAREFULLY  
BEFORE USING

---

## Quick Start

---

### WARNING

- Use outdoors only. Generators produce carbon monoxide — a poisonous, colorless, odorless gas that can cause death or serious injury.
- Always operate on a level surface
- Keep away from rain, snow or other wet conditions
- Keep away from smoking materials, sparks, and other sources of combustion when refueling.

### Pre-Operation:

1. Check the oil level by removing the maintenance cover and inspecting the dipstick. Fill reservoir with 15.2 oz. (0.45 L) oil or to the full mark on the dipstick. Use appropriate grade, high-detergent, premium quality, 4-stroke engine oil.
2. Remove the battery access cover and connect the battery. Secure with battery strap.
3. Add regular unleaded automotive gasoline up to the shoulder of the fuel strainer. Avoid getting dirt, dust, or water in the fuel tank. Do not use a blend that contains more than 10% ethanol. Do not use gasoline containing methanol. Octane rating of 87 or higher is recommended.

### Operation

### CAUTION

For operation at high altitudes and in extreme temperatures, see the complete operating instructions.

1. Ensure that no loads have been connected to the AC receptacles.
2. Open the fuel valve. If the fuel tank was empty, it may be necessary to pump the primer bulb to get fuel to the carburetor.
3. Start the engine in one of the following ways.
  - A. Electric Start:
    - Insert the ignition key, and turn it all the way to the START position. Hold key at this position until the engine is running or for a maximum of 10 seconds. Release and repeat if necessary.
  - B. Manual Start:
    - Turn the ignition switch to the ON position.
    - Pull the starter grip lightly until resistance is felt, then pull briskly out.
  - C. Remote Start:
    - Turn the remote switch to the ON position.
    - Push the start button on the remote twice and hold until the engine has started or for a maximum of 10 seconds. Release and repeat if necessary.
    - Always turn the remote switch to the "OFF" position when not in use to prevent running down the battery.
4. The green "run" light will illuminate when the generator is ready for use. Before connecting any loads, ground the generator with a length of heavy cable, connecting the generator's grounding terminal to an external ground source.
5. Make sure that all appliances to be connected have been switched off and are in good working order. Confirm that the electrical rating does not exceed that of the generator.
6. Connect the appliance to the appropriate receptacle on the generator's panel.
7. To minimize fuel consumption and noise, turn on the *Economy* switch. This setting regulates the engine's speed so that it matches the needs of the connected loads.

### Shutdown

### NOTE

In an emergency, pushing the STOP button on the control panel will automatically stop the engine without the ignition key or remote, with or without a load. However, continually stopping the generator without disconnecting all loads can cause damage to the generator or appliances.

1. Turn off all connected appliances and disconnect from the generator.
2. Use one of the following methods to turn off the generator
  - A. If the remote switch is OFF:
    - Turn the ignition key to the STOP position.
  - B. If the remote switch is ON:
    - Push and hold the stop button on the remote or on the panel.

---

## PREFACE

---

Thank you for purchasing a POWERHOUSE® generator.

This manual covers operation and maintenance of POWERHOUSE® generator-model PH2100PRI with remote start.

All information in this publication is based on the latest product information available at the time of approval for printing.

We reserve the right to make changes at any time without notice and without incurring any obligation.

No part of this publication may be reproduced without written permission.

This manual should be considered a permanent part of the generator and should remain with it if it is resold.

Pay special attention to statements preceded by the following words:

### WARNING

- Indicates a strong possibility of severe personal injury or death if instructions are not followed.

### CAUTION

- Indicates a possibility of personal injury or equipment damage if instructions are not followed.

### NOTE

- Gives helpful information.

If a problem should arise, or if you have any questions about the generator, consult an authorized Powerhouse dealer.

### WARNING

- Failure to properly follow these precautions can result in property damage, serious injury, or DEATH!
- Read all labels and the owner's manual before operating this generator.
- Generators produce carbon monoxide — a poisonous, colorless, odorless gas that can cause death or serious injury.
- Indoor use of a generator can kill quickly. Generators should be used outdoors only.
- Generators should only be used outdoors away from garages and open windows, but protected from rain and snow.
- Check for spilled fuel or leaks. Clean and/or repair before use.
- Always stop engine before refueling. Wait 5 minutes before restarting.
- Keep any source of ignition away from fuel tank, at all times.
- The portable generator is not meant to be used as a permanent back-up power system for the home. A permanently installed stationary generator is designed to be safely used for this specific purpose.

### WARNING

Our generators are designed to give safe and dependable service if operated according to instructions. Read and understand the Owner's Manual before operating the generator. Failure to do so could result in personal injury or equipment damage.

---

## FCC INFORMATION

---



**Trade Name:** Coast Distribution Inc.

**Model:** PH2100PRi

This device complies with Part 15 of the FCC Rules. Operation is subject to the following two conditions: (1) this device may not cause harmful interference, and (2) this device must accept any interference received, including interference that may cause undesired operation.

Pursuant to FCC regulations, do not to make any changes or modifications to the remote control transmitter or receiver that are not expressly approved by Coast Distribution Inc. Doing so could void your authority to operate the equipment and will void the warranty.

### Notice

This equipment has been tested and found to comply with the limits for a Class B digital device, pursuant to Part 15 of the FCC Rules. These limits are designed to provide reasonable protection against harmful interference in a residential installation. This equipment generates uses and can radiate radio frequency energy and, if not installed and used in accordance with the instructions, may cause harmful interference to radio communications. However, there is no guarantee that interference will not occur in a particular installation.

If this equipment does cause harmful interference to radio or television reception, which can be determined by turning the equipment off and on, the user is encouraged to try to correct the interference by one or more of the following measures:

- Reorient or relocate the receiving antenna.
- Increase the separation between the equipment and receiver.
- Connect the equipment into an outlet on a circuit different from that to which the receiver is connected.
- Consult the dealer or an experienced radio/TV technician for help.

---

# CONTENTS

---

<b>OPERATING INSTRUCTIONS</b> .....	1
Quick Start .....	2
Pre-Operation: .....	2
Operation .....	2
Shutdown .....	2
PREFACE .....	3
FCC INFORMATION .....	4
CONTENTS .....	5
1. SAFETY INSTRUCTIONS .....	7
2. COMPONENT IDENTIFICATION .....	9
2.1 Control panel PH2100PRi .....	10
2.2 Serial number and bar code identification and location .....	11
3. PRE-OPERATION CHECK .....	12
3.1 Check the engine oil level. ....	12
3.2 Check the fuel level. ....	13
3.3 Check the air cleaner.....	14
3.4 Connecting the battery .....	15
3.5 Battery Removal .....	15
4. OPERATING INSTRUCTIONS .....	16
4.1 Starting the engine.....	16
4.2 Starting procedure using the ignition key .....	16
4.3 Manual Start.....	17
4.4 Starting procedure using the remote function .....	18
4.5 High altitude operation.....	19
4.6 Generator use.....	20
4.7 AC application.....	22
4.8 Output and Overload Lights.....	23
4.9 DC application .....	24
4.10 Low oil alarm system .....	25
4.11 Economy switch.....	26
4.12 Stopping the engine.....	26
5. PARALLEL GENERATOR OPERATION ( <i>with optional kit #69276</i> ) .....	27
5.1 Parallel operating features.....	27
5.2 Air Conditioning Operation (13,500-15,000 btu) .....	27
6. MAINTENANCE .....	28
6.1 Emission control system.....	28
6.2 Maintenance Schedule .....	30
6.3 Changing oil.....	31
6.4 Air cleaner service .....	32
6.5 Spark plug maintenance .....	33
6.6 Spark arrestor maintenance .....	35
7. TRANSPORTING and STORAGE .....	36
7.1 Exercising the Generator.....	36

7.2 Before storing the unit for an extended period .....	37
8. TROUBLESHOOTING .....	38
8.1 Engine will not start: .....	38
8.2 Appliance does not operate: .....	39
8.3 No output at the DC receptacle: .....	39
9. SPECIFICATIONS .....	40
10. WARRANTY AND CONSUMER INFORMATION .....	42
POWERHOUSE® GENERATOR WARRANTY .....	42
CALIFORNIA EMISSIONS CONTROL WARRANTY STATEMENT .....	43
EMISSION CONTROL SYSTEM WARRANTY .....	44
11. APENDIX B - EMISSION CONTROL SYSTEM .....	45
12. APENDIX C - SAFETY AND CHARGING INSTRUCTIONS .....	46

# 1. SAFETY INSTRUCTIONS

## WARNING



- This generator is designed to give safe and dependable service if operated according to instructions.

Read and understand the Owner's Manual before operating the generator. Failure to do so could result in personal injury or equipment damage.

## WARNING



- Exhaust gas contains poisonous carbon monoxide. Never run the generator in an enclosed area.

Be sure to provide adequate ventilation.

## WARNING



- The muffler becomes very hot during operation and remains hot for several minutes after stopping the engine.

Be careful not to touch the muffler while it is hot.

Let the engine cool before storing the generator indoors.

### To ensure safe operation

## WARNING

- Gasoline is extremely flammable and explosive under certain conditions. Refuel in a well ventilated area with the engine stopped.
- Keep away from cigarette smoke and sparks when refueling the generator.
- Wipe up spilled gasoline at once.

**⚠ WARNING**



- This generator is not intended, nor designed, for use as a standby power supply and should never be used as such. Severe property damage and/or severe personal injury or death may result. Never connect this generator to an automatic transfer switch (ATS). Severe damage to the generator will occur.

**⚠ WARNING**

- Always make a pre-operation inspection before you start the engine. You may prevent an accident or equipment damage.
- Place the generator at least 3 ft (1 m) away from buildings or other equipment during operation.
- Operate the generator on a level surface. If the generator is tilted, fuel spillage may result.
- Know how to stop the generator quickly and understand operation of all controls. Never permit anyone to operate the generator without proper instructions.
- Keep children and pets away from the generator when it is in operation.
- Keep away from moving parts while the generator is running.
- The generator is a potential source of electrical shocks when misused; do not operate with wet hands.
- Do not operate the generator in rain or snow and do not let it get wet.
- Do not install this generator inside a compartment. Doing so may lead to overheating and consequently, fire. It may also lead to death by asphyxiation.
- Do not modify the enclosure of this generator.

## 2. COMPONENT IDENTIFICATION

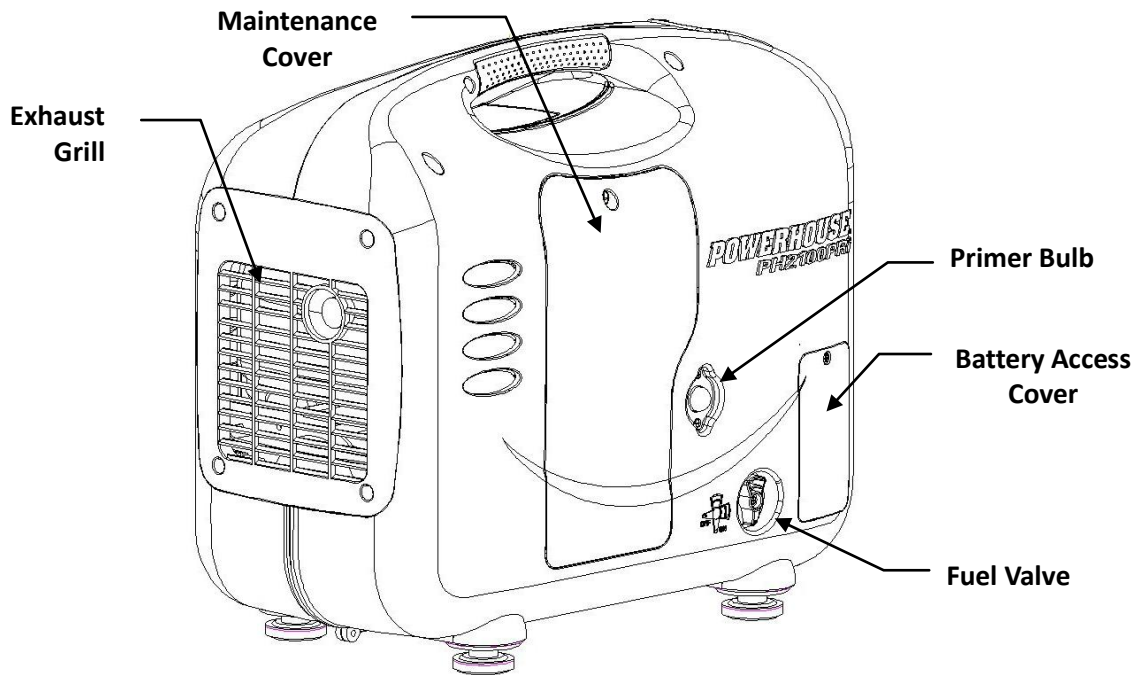
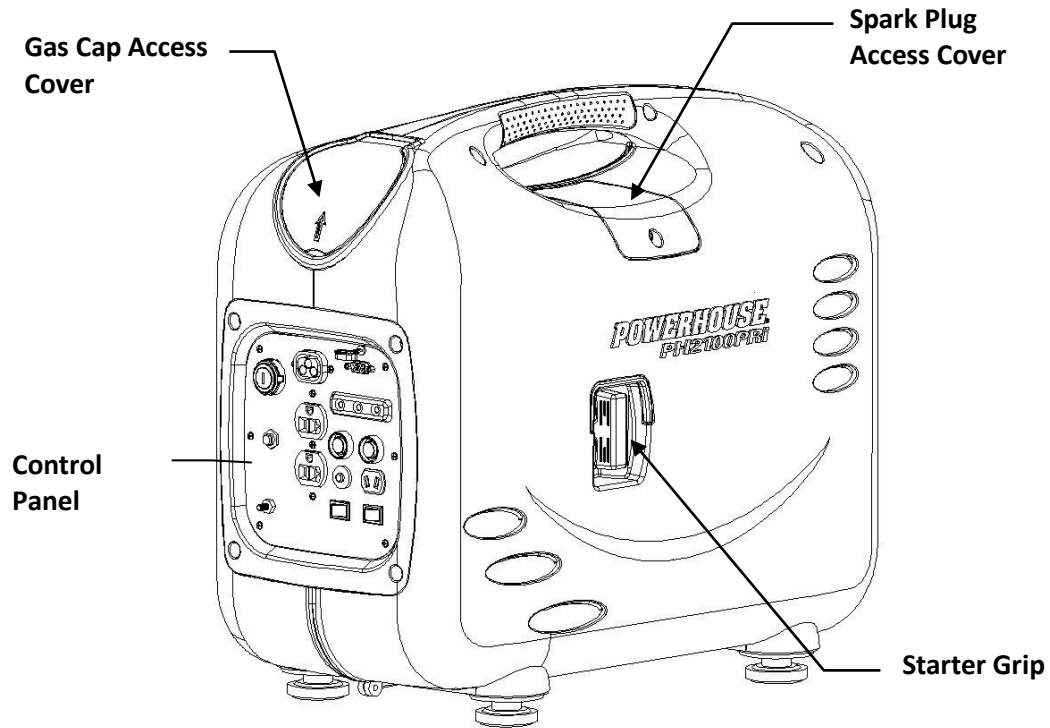

## 2.1 Control panel PH2100PRi

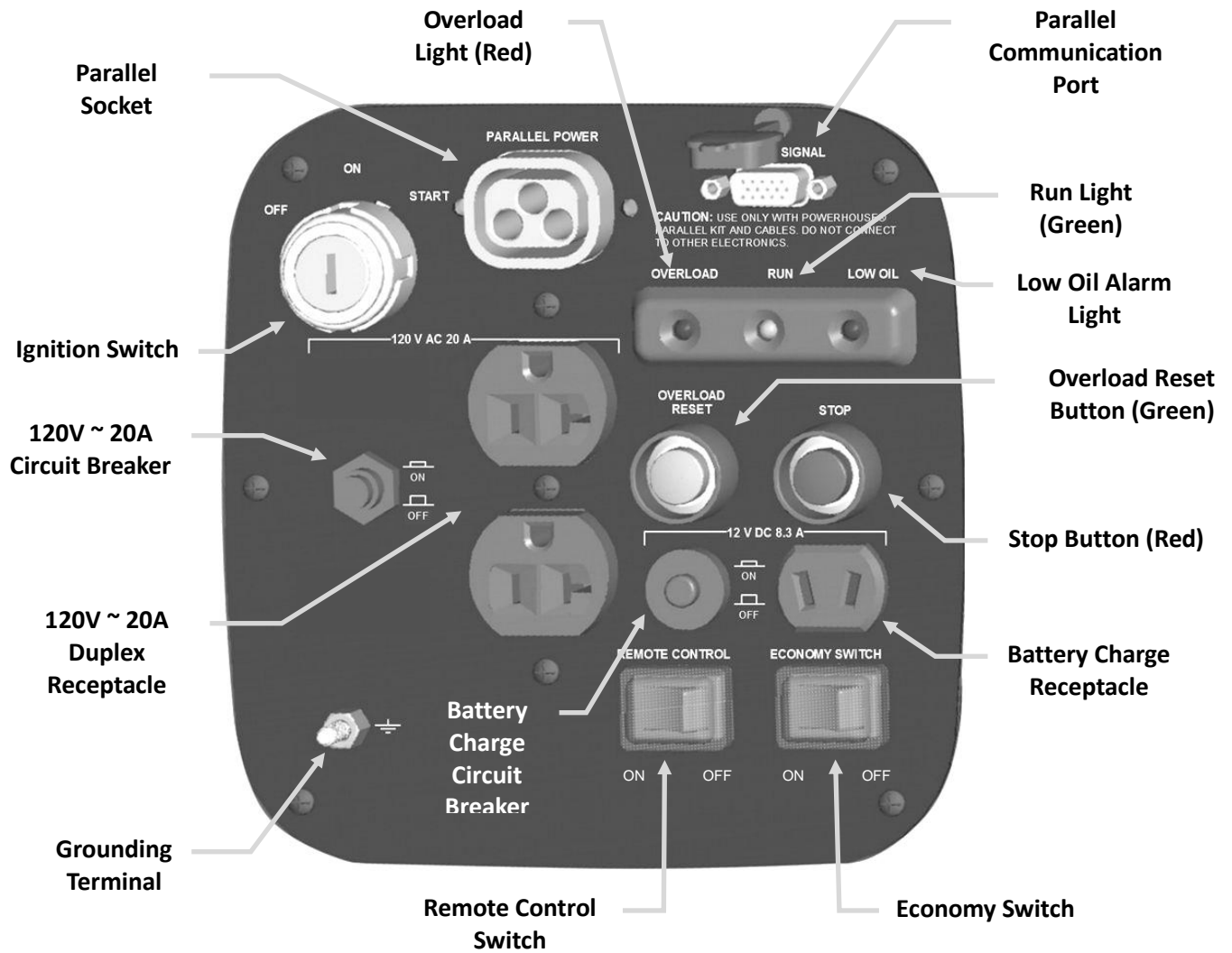

## 2.2 Serial number and bar code identification and location

The generator serial number identifies your particular unit and is necessary when ordering parts and accessories. The bar code is used by your dealer and Coast Distribution for warranty administration and must be supplied before any work can be done.

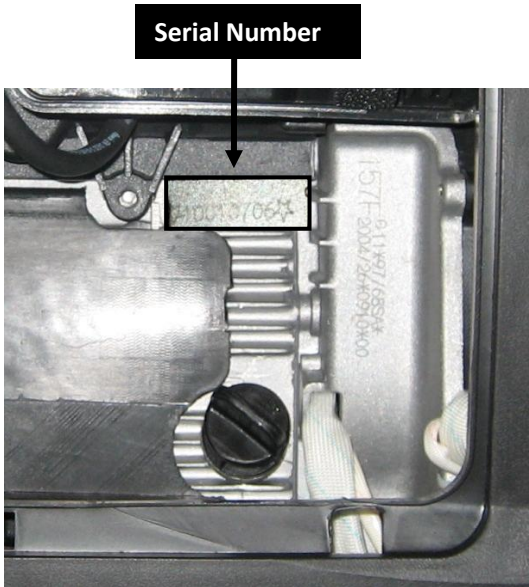

The serial number can be found stamped on the engine block above oil dipstick. It is visible when the maintenance panel is removed.



The bar code label is found in two locations:

1. On the bottom of the generator.
2. On the packing carton.

Please record this information below and keep this manual in a safe place along with the bill of sale.

Engine Serial Number \_\_\_\_\_

Bar Code Number \_\_\_\_\_

Date of Purchase \_\_\_\_\_

Name of Selling Dealership \_\_\_\_\_

Please go to [www.powerhouse-products.com/register](http://www.powerhouse-products.com/register) and register your unit today. Online registration will be accepted as proof of purchase. Online registration will make sure you are protected in the event you have lost your receipt, and will significantly speed the process in the event warranty service is necessary.

For warranty assistance:

Phone: 877-544-4449

Fax: 800-263-0280

E-mail: [warranty@powerhouse-products.com](mailto:warranty@powerhouse-products.com)

### 3. PRE-OPERATION CHECK

**! WARNING**

- Be sure to check the generator on a level surface with the engine stopped.

#### 3.1 Check the engine oil level.

**! CAUTION**

- Do not use non-detergent oil or 2-stroke engine oil. It will void the warranty and will shorten the engine's service life.
- Use a high-detergent, premium quality, 4-stroke engine oil, certified to meet or exceed U.S. automobile manufacturer's requirements for API Service Classification SG/SF.
- Select the appropriate viscosity for the average temperature in your area.

**SAE Viscosity Grades**

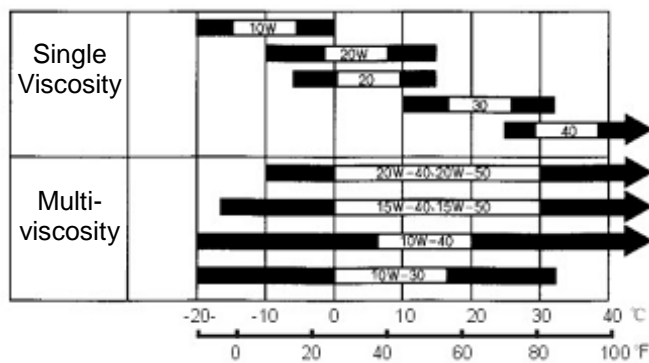

**Ambient Temperature**

1. Loosen the cover screw and remove the maintenance cover.
2. Wipe the dipstick with a clean rag, and reinsert the dipstick back into the filler neck, screwing it down completely.
3. If the oil level is at or below the lower level of the dipstick, refill the recommended oil up to the top of the upper level marking. Do not overfill.

**! WARNING**

- Running the engine with insufficient oil can cause serious engine damage.
- The Low Oil Alarm System will automatically stop the engine before the oil level falls below a safe limit. However, to avoid the inconvenience of an unexpected shutdown, it is still advisable to visually inspect the oil level regularly.

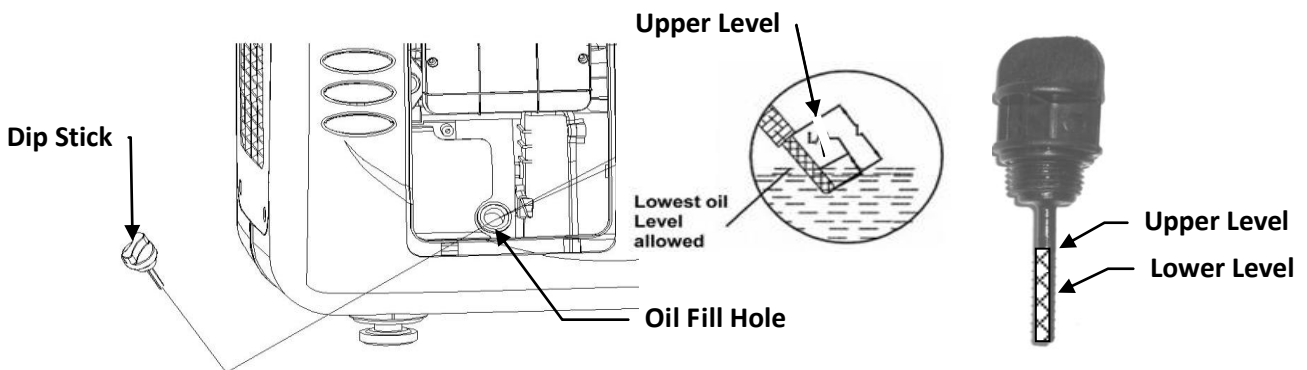

### 3.2 Check the fuel level.

Use automotive unleaded regular gasoline only.

1. If the fuel level is low, refill to the shoulder of the fuel strainer.
2. Never use an oil/gasoline mixture or dirty gasoline.
3. Avoid getting dirt, dust or water in the fuel tank.
4. After refueling, tighten the fuel filler cap securely.

#### **! WARNING**

- Gasoline is extremely flammable and is explosive under certain conditions.
- Refuel in a well-ventilated area with the engine stopped. Keep all smoking materials, sparks, and any other source of combustion away from the generator during refueling.
- Do not overfill the fuel tank (there should be no fuel above the upper limit mark). After refueling, make sure the tank cap is closed properly and securely.
- Be careful not to spill fuel when refueling. Spilled fuel or fuel vapor may ignite. If any fuel is spilled, make sure the area is dry before starting the engine.
- Avoid repeated or prolonged contact with skin or breathing of vapor. **KEEP OUT OF REACH OF CHILDREN.**

Fuel tank capacity: 1.3 gal (5 liters)

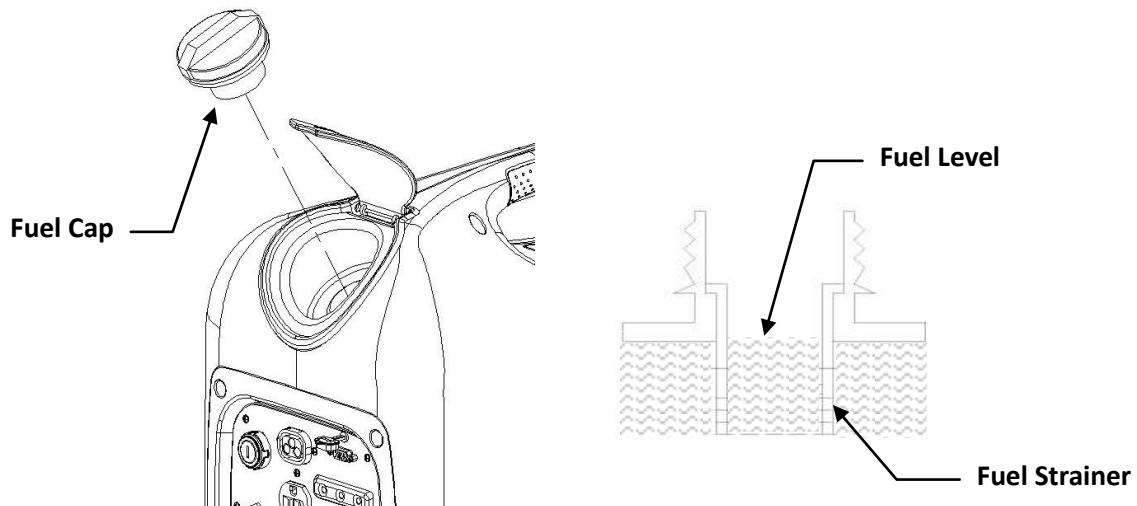

#### **Gasoline containing alternate fuels**

Do not use a blend that contains more than 10% ethanol. Do not use gasoline containing methanol. Octane rating of 87 or higher is recommended.

**NOTE**

- Fuel system damage or engine performance problems resulting from the use of fuels that contain an improper alcohol blend are not covered under warranty.
- Before buying fuel from an unfamiliar station, determine if the fuel contains ethanol and if it does, confirm the type and percentage of ethanol used. If you notice any undesirable operating symptoms while using a gasoline that contains ethanol, or one that you think contains ethanol, replace it with a gasoline that you know has the proper blend.

### 3.3 Check the air cleaner

Check the air cleaner element to be sure it is clean and in good condition.

Loosen the panel screw and remove the maintenance cover.

Remove two air filter retaining screws. Remove the cover and check the element. Clean or replace the element if necessary.

**CAUTION**

- Never run the engine without the air cleaner.
- Rapid engine wear will result from contaminants, such as dust and dirt being drawn through the carburetor into the engine.

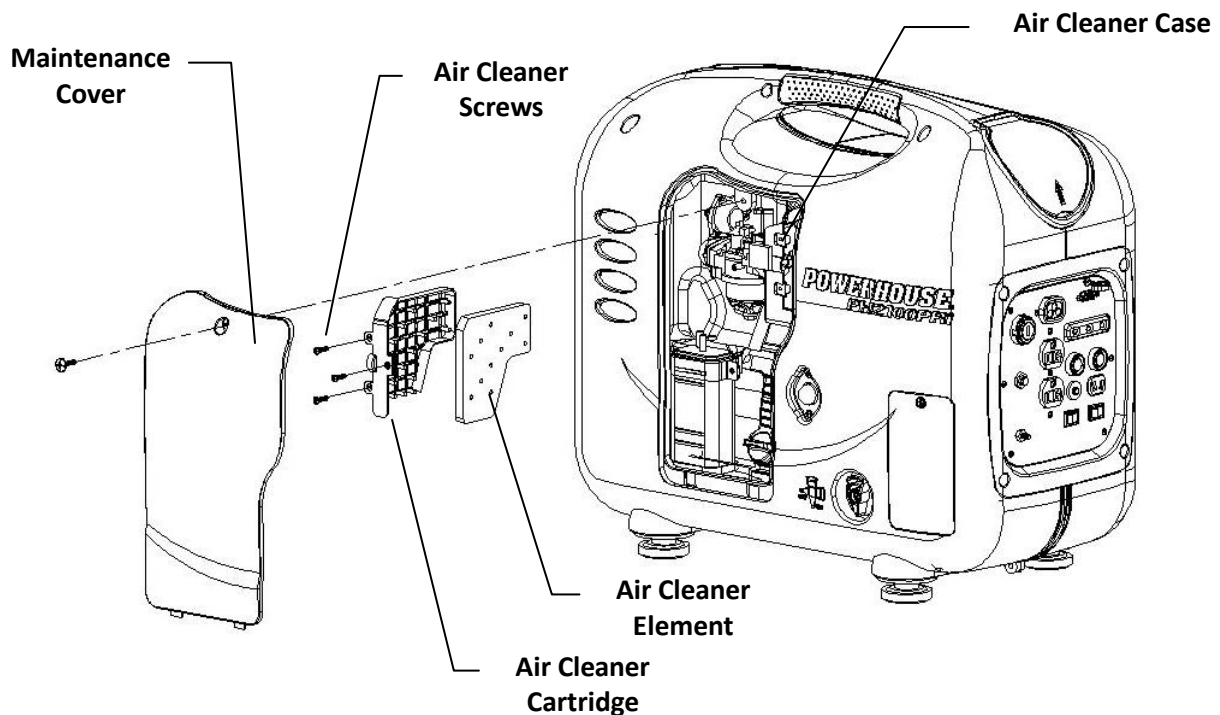

### 3.4 Connecting the battery

1. Loosen the cover screw and remove the battery access cover.
2. To connect the battery, plug the 2 connectors together.

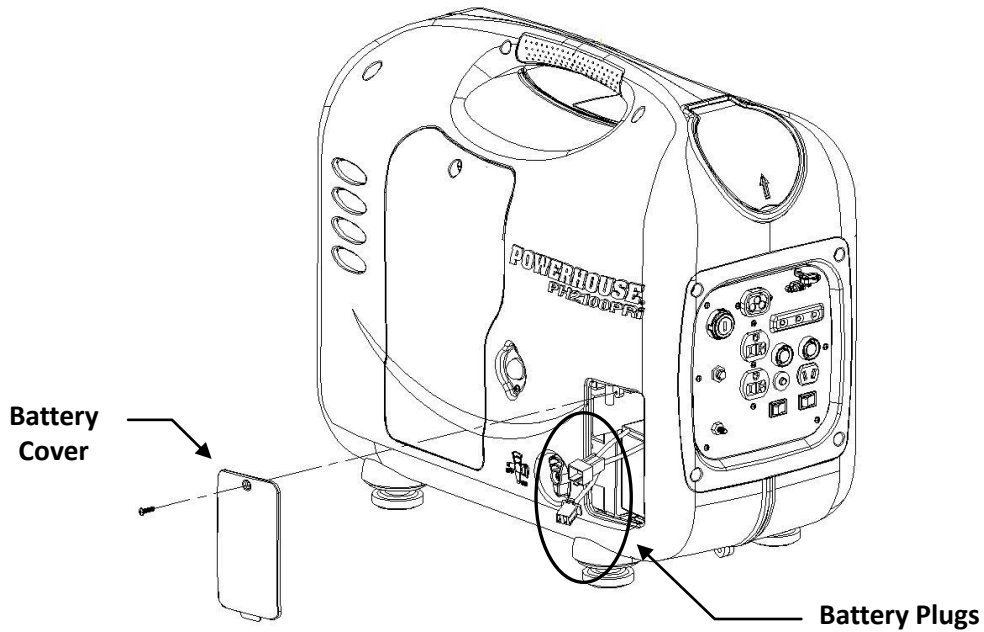

### 3.5 Battery Removal

1. To remove the battery for maintenance or replacement.
2. Loosen the cover screw and remove the battery access cover.
3. Unplug the battery and unhook the battery strap and slide out.

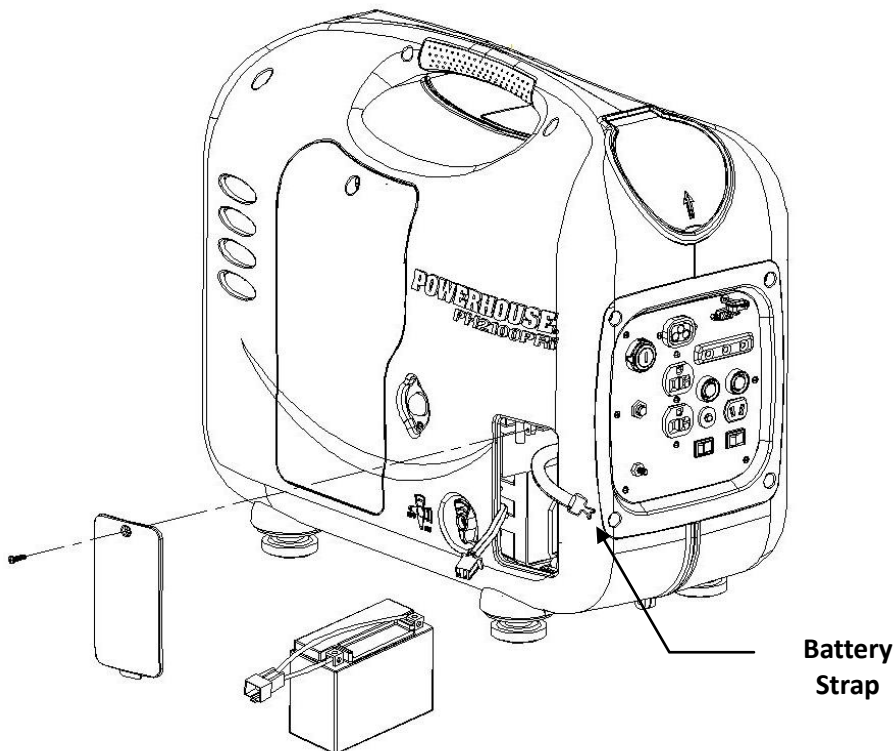

## 4. OPERATING INSTRUCTIONS

### 4.1 Starting the engine

#### NOTE

- This unit can be started by either the ignition key or remote. When the unit is started with the ignition key, it can be shut down by the ignition key or the Emergency shut-down button on the control panel; but NOT by the remote. When the unit is started by the remote, it can be shut down by the remote. If you want to shut down the unit with the ignition key when the unit has been started by remote, you will need to turn the remote control switch on the control panel to the “OFF” position before you can shut off the unit with the ignition key. The unit can always be shut down by the Emergency button on the control panel no matter how you start the unit.

Before starting the engine, disconnect any load from the AC receptacles.

### 4.2 Starting procedure using the ignition key

1. Turn the fuel valve to the “ON” position.
2. If the fuel tank was empty it may be necessary to pump the primer bulb several times to get fuel to the carburetor.
3. Move the remote selector switch to the “OFF” position.
4. Turn the ignition switch to the START position until the engine has started. Do not operate the starter for more than 10 seconds. Repeat if necessary.

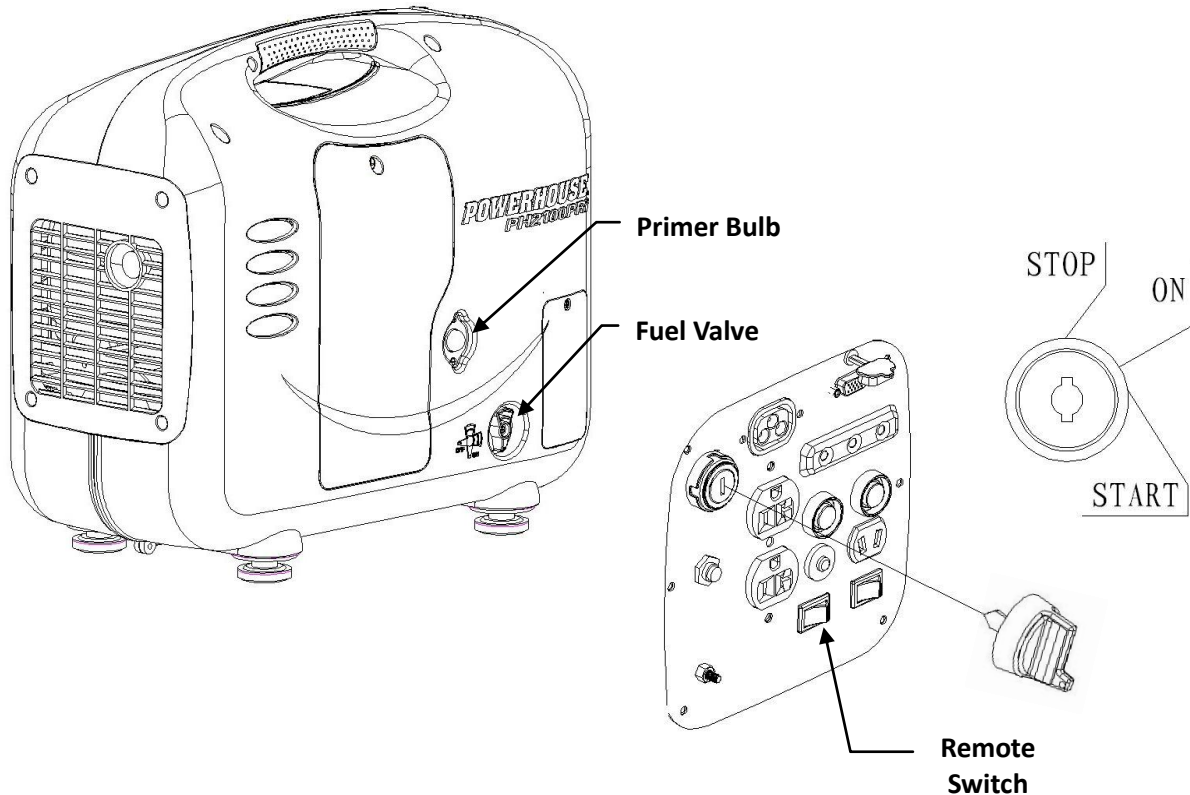

## 4.3 Manual Start

1. Turn the fuel valve lever to the “ON” position.
2. If the fuel tank was empty it may be necessary to pump the primer bulb several times to get fuel to the carburetor.
3. Move the remote selector switch to the “OFF” position.
4. Turn the ignition switch to the “ON” position.
5. Pull the starter grip lightly until resistance is felt, then pull briskly out.

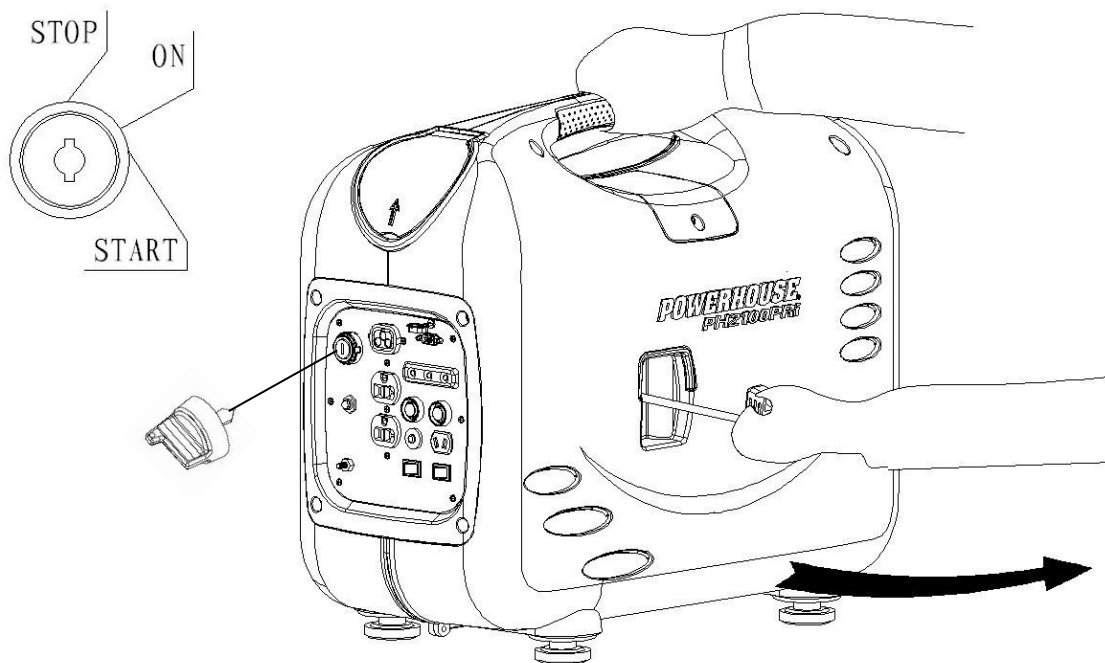

### CAUTION

- Do not allow the starter grip to snap back. Return it slowly by hand.
- Do not let the starter rope rub against the generator body or the rope will wear out prematurely.

## 4.4 Starting procedure using the remote function

1. Turn the fuel valve lever to the “ON” position.
2. Move the remote selector switch to the “ON” position.
3. If the fuel tank was empty it may be necessary to pump the primer bulb several times to get fuel to the carburetor.

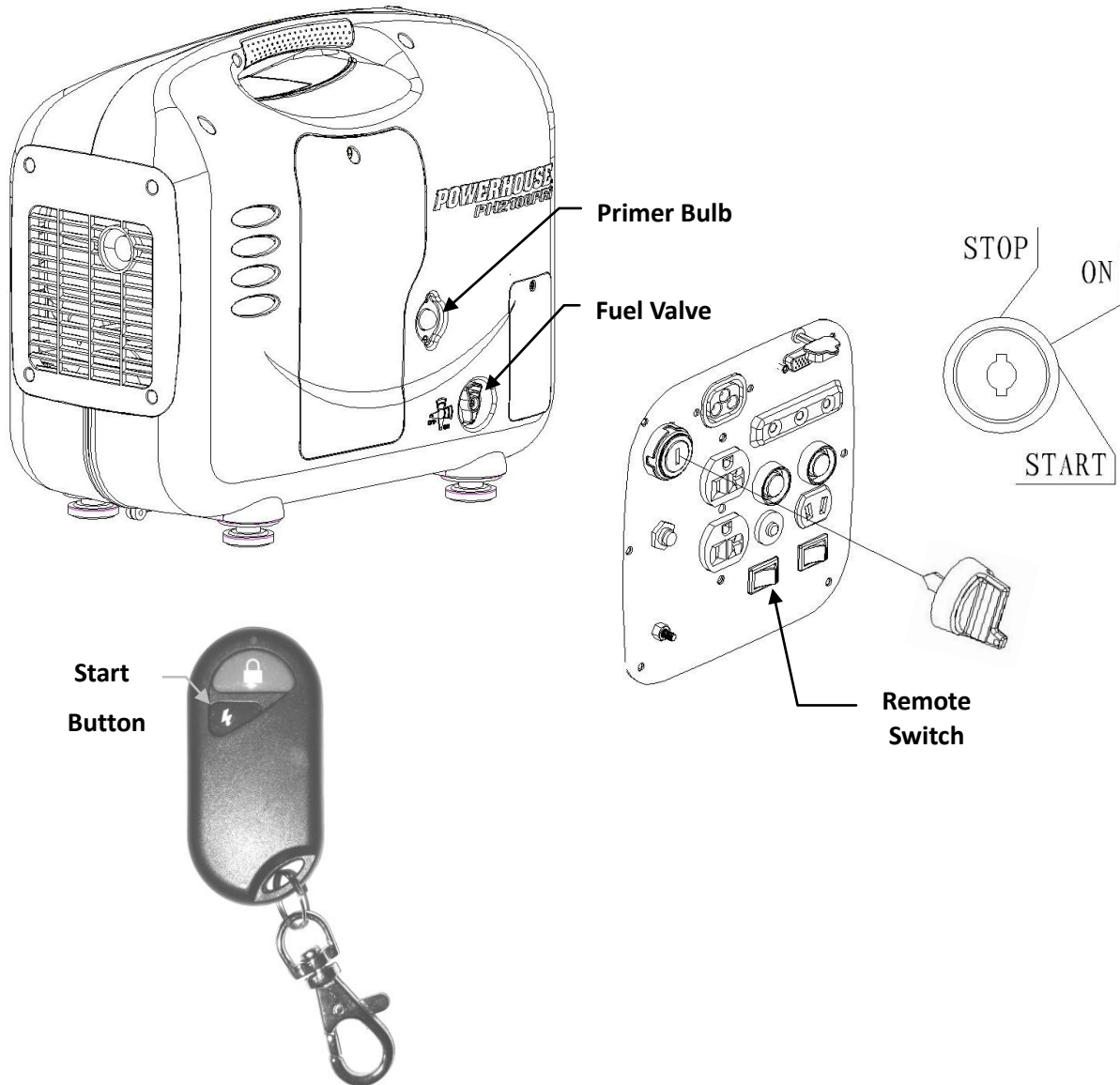

4. Push the start button on the remote twice and hold until the engine has started. Do not operate the starter for more than 10 seconds. Repeat if necessary.

### **NOTE**

- The maximum operating range is 75' based on a clear line of site.
- **Always put the remote switch on the generator in the “OFF” position when not in use, to prevent running down the battery.**

## 4.5 High altitude operation

At higher altitudes, the standard carburetor air-fuel mixture will be excessively rich. Performance will decrease, and fuel consumption will increase. Power output will decrease 3.5% for each 1000 feet (305 m) above sea level.

High altitude performance can be improved by installing a smaller diameter main fuel jet in the carburetor. If you always operate the generator at altitudes higher than 5000 feet (1500 m) above sea level, have your authorized dealer install a high altitude main jet.

Even with suitable carburetor jetting, engine horsepower will decrease approximately 3.5% for each 1000 feet (305 m) increase in altitude. The affect of altitude on the horsepower will be greater than this if no carburetor modification is made.



- Operation of the generator at an altitude lower than the carburetor is jetted for may result in reduced performance, overheating, and serious engine damage caused by an excessively lean air/fuel mixture.
- Be sure to have any modification reversed at lower altitudes.

## Temperature

High temperature adversely affects generator operation. Generator performance will decrease 1% for each 10°F (5.5°C) increase in temperature above 85°F (29°C). The normal operating range of this generator is -20° to 113° F (-29° to 45°C).



- Do not operate the generator when the ambient temperature is below -20°F (-29°C).
- Do not operate the generator when the ambient temperature exceeds 113°F (45°C).

## 4.6 Generator use

Be sure to ground the generator when loads are connected.

### **⚠ WARNING**

- To prevent electrical shock from faulty appliances, the generator should be grounded. Connect a length of heavy cable between the generator's ground terminal and an external ground source.
- Connections for standby power to a building's electrical system must be made by a qualified electrician and must comply with all applicable laws and electrical codes. Improper connections can allow electrical current from the generator to back feed into the utility lines. Such back feed may electrocute utility company workers or others who contact the lines during a power outage. When utility power is restored the generator may explode, burn, or cause fires in the building's electrical system.
- Do not connect the generator to an automatic transfer device. Severe damage to the inverter module may result.

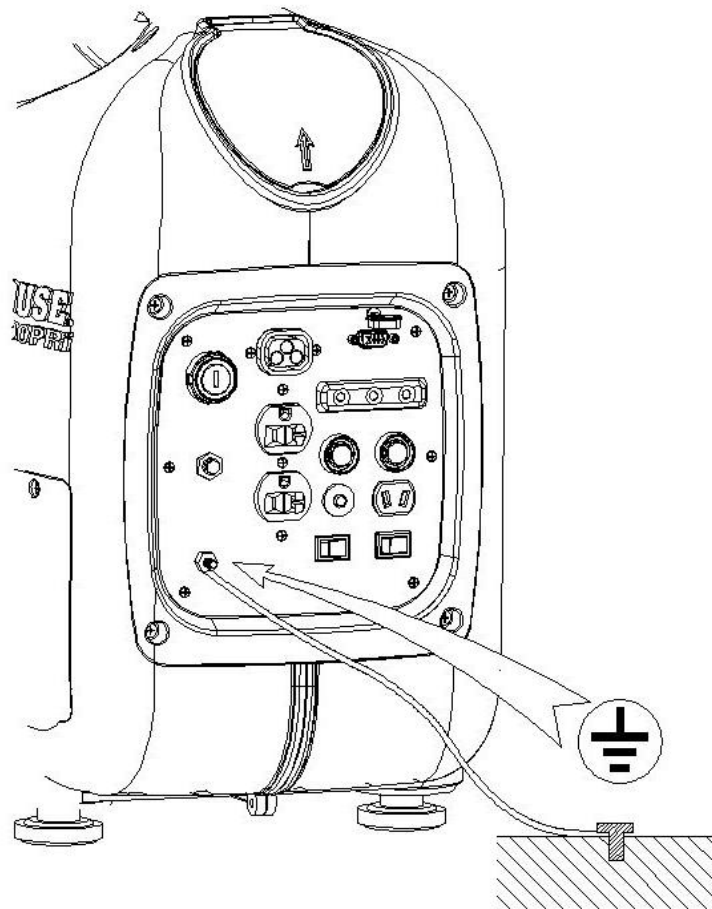

 **CAUTION**

- The total wattage of all appliances connected must be considered.
- Do not exceed the current limit specified for any one receptacle.
- Do not connect the generator to a household circuit. This could cause the damage to the generator or to electrical appliances in the house.
- Do not modify or use the generator for other purpose than it is intended for. Also observe the following when using the generator.
- Do not connect an extension to exhaust pipe.
- When an extension cable is required, be sure to use a rubber sheathed flexible cable.
- When an extension cable is required, make sure you use the proper size and length.
  - 16 Gauge Cords- Any 16 gauge cord between 0 and 100 feet long will adequately handle tool and appliance loads up to 10 amps.
  - 14 Gauge Cords- a 14 gauge cord between 0 and 50 feet long will adequately handle loads between 10 and 15 amps.
  - 12 Gauge Cords- If your load is between 10 and 15 amps and the length of the cord is 50 to 100 feet, you need a 12 gauge cord to safely power any tool.-
- Keep the generator away from other electric cables or wires such as commercial power supply lines.

 **NOTE**

- The DC receptacle can be used while the AC power is in use. If you use both at the same time, be sure not to exceed the total power for AC and DC.
- Most appliance motors require more than their rated wattage for start-up.

## 4.7 AC application

1. Start the engine and make sure only the output Run indicator light (Green) comes on.
2. Confirm that the appliance to be used is switched off before plugging into the control panel.



### CAUTION

- Substantial overloading that continuously lights the overload light (Red) may damage the generator. Marginal overloading that temporarily lights the overload light (red) may shorten the service life of the generator.
- Be sure that all appliances are in good working order before connecting them to the generator. If an appliance begins to operate abnormally, becomes sluggish, or stops suddenly, turn off the generator engine switch immediately. Disconnect the appliance and examine it for signs of malfunction.

### NOTE

- In order to insure the optimum output and the maximum service life of the generator, the generator should run at a 50% load for the first 20 hours.

## 4.8 Output and Overload Lights

1. The output indicator light (Green) will remain illuminated during normal operating conditions.
2. If the generator is overloaded (in excess of 2.1 kW), or if there is a short in the connected appliance, the output indicator light (Green) will go out, the overload indicator light (red) will turn on and current to the connected appliance will be shut off.
3. Remove all electrical loads from the generator and investigate the cause of the overload.
4. To reset the overload condition (Red light), press the (Green) overload reset button or stop and restart the generator. The (Green) indicator light should be illuminated within 10 seconds.

### NOTE

- Before connecting or reconnecting an appliance to the generator, check that it is in good order, and that its electrical rating does not exceed that of the generator.
- When an electric motor is started, both the overload indicator light (red) and the output indicator light (green) may go on simultaneously. This is normal.

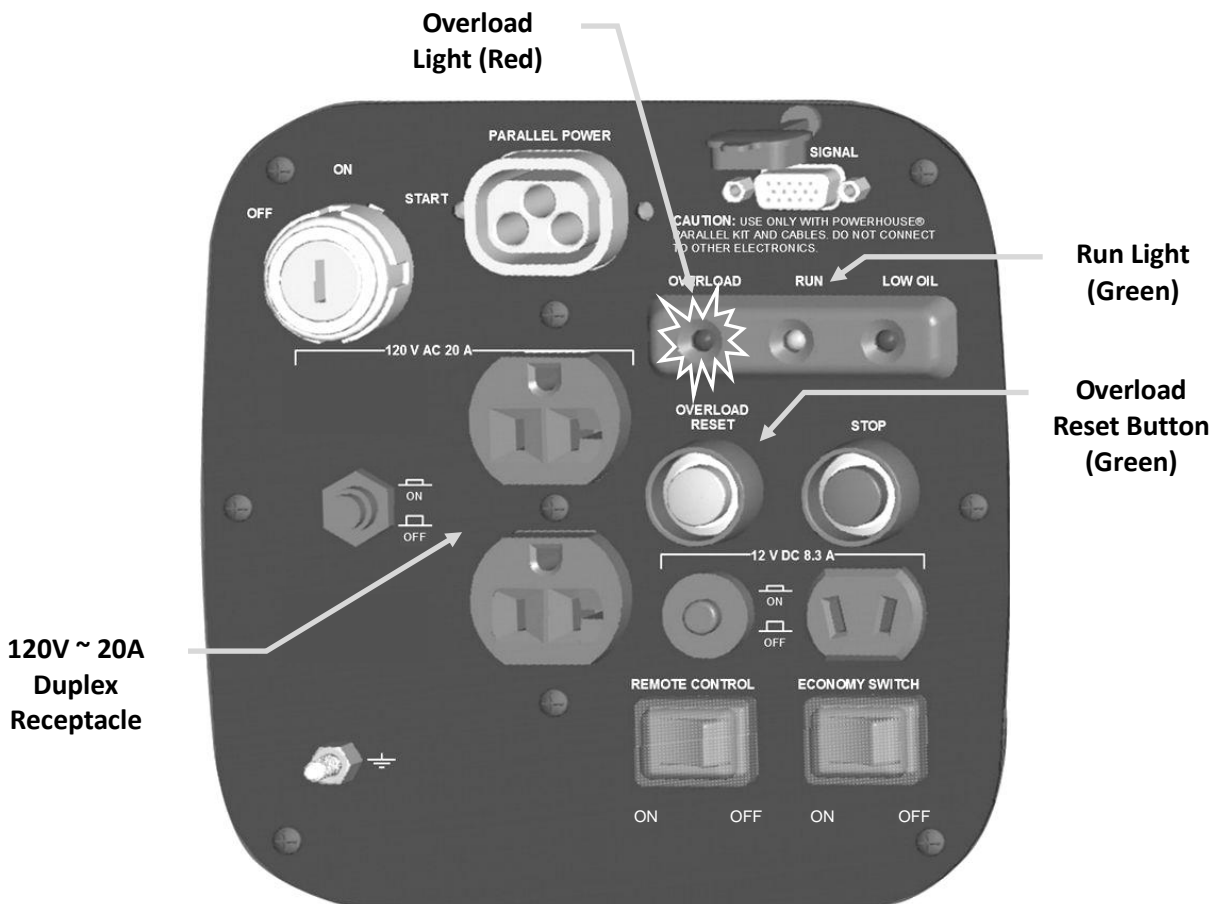

## 4.9 DC application

### **! WARNING**

- **The DC receptacle may be used for charging 12 volt lead acid batteries only. Other types of batteries may burst causing personal injury or damage.**
- To prevent the possibility of creating a spark near the battery, connect the charging cable first to the battery then to the generator. Disconnect the cable first at the generator.
- Before connecting charging cables to a battery that is installed in a vehicle, disconnect the vehicle's ground battery cable. Reconnect the vehicle's ground battery cable after the charging cables are removed. This procedure will prevent the possibility of a short circuit and sparks if you make accidental contact between a battery terminal and the vehicle's frame or body.

### **! CAUTION**

- Do not attempt to start an automobile engine with the generator still connected to the battery. The generator may be damaged.
- Connect the positive charging cord to the positive battery terminal. Do not reverse the charging cables, or serious damage to the generator and/or battery may occur.
- DC operation is only intended for the purpose of charging batteries. It should not be used to power DC equipment.

1. For DC operation, with the engine running, turn the Economy switch to the OFF position
2. Connect the charging cables to the battery terminals first.
3. Connect the charging cables to the DC receptacle of the generator last.

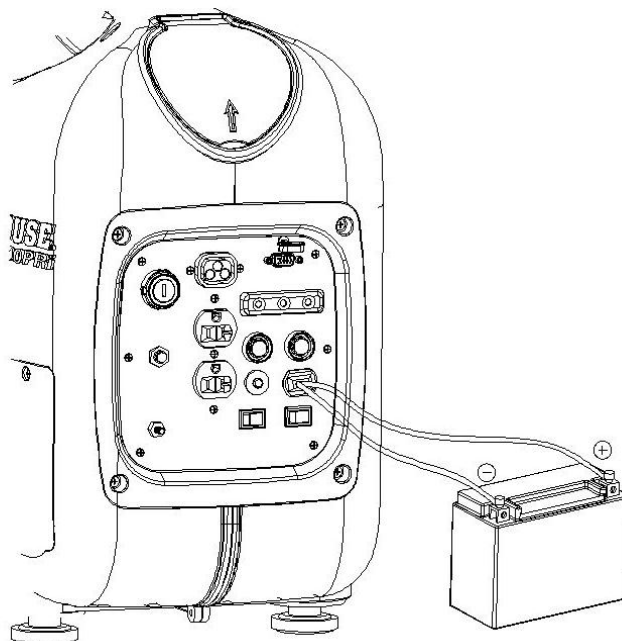

## ⚠ WARNING

- The battery gives off explosive gases; keep spark, flames and cigarettes away. Provide adequate ventilation when charging.
- The battery contains sulfuric acid (electrolyte). Contact with skin or eyes may cause severe burns. Wear protective clothing and a face shield.
  - If electrolyte gets on your skin, flush with water.
  - If electrolyte gets in your eyes, flush with water for at least 15 minutes and call a physician.
- Electrolyte is poisonous.
  - If swallowed, drink large quantities of water or milk and follow with milk of magnesia or vegetable oil and call a physician.
- KEEP OUT OF REACH OF CHILDREN.

## ⚠ NOTE

- The DC receptacle may be used while the AC power is in use.
- An overloaded DC circuit will trip the DC circuit breaker. If this happens reset the circuit breaker to resume operation.

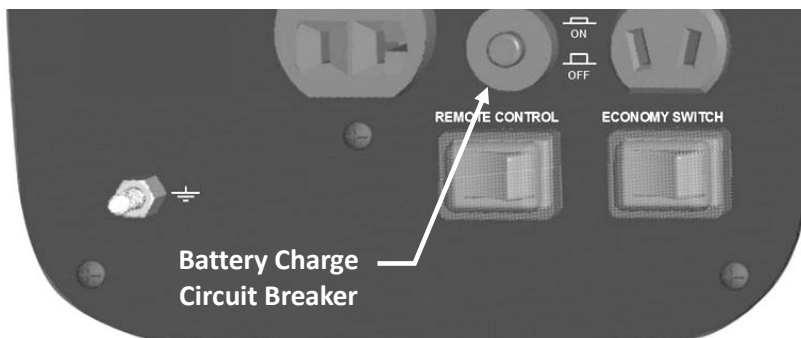

### 4.10 Low oil alarm system

The low oil alarm system is designed to prevent engine damage caused by an insufficient amount of oil in the crankcase. Before the oil level in the crankcase falls below a safe limit, the low oil alarm system will automatically shut down the engine (the engine switch will remain in the ON position).

If the low oil alarm system shuts down the engine, the low oil alarm indicator light (red) will come on when you operate the starter and the engine will not run. If this occurs add engine oil.

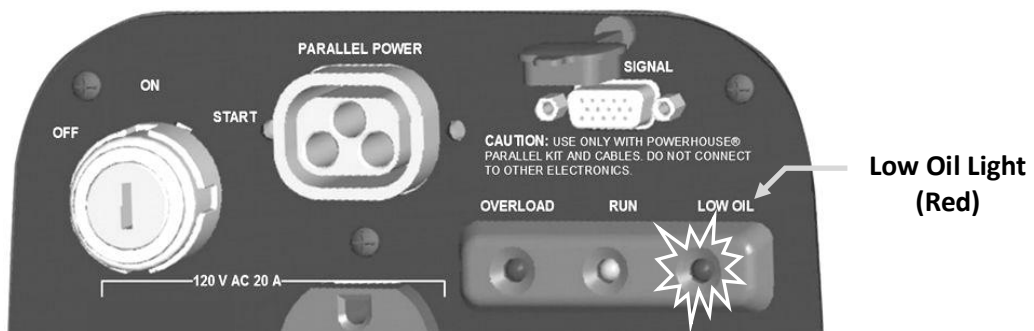

## 4.11 Economy switch

Economy switch “ON”: This position is recommended to minimize fuel consumption and noise while in operation. Engine speed is kept at idle automatically when the electrical load is disconnected and returns to the proper speed to match the power of the electrical load when the load is reconnected.



### NOTE

- Economy system does not operate effectively if the electrical appliance requires rapid on-off cycling of power.
- When high electrical loads are connected simultaneously, turn the Economy switch to the “OFF” position to reduce voltage fluctuation or shutdown.
- In DC operation, turn the Economy switch to the “OFF” position.

Economy switch “OFF”: The system does not operate. Engine runs at the rated load (RPM).



## 4.12 Stopping the engine

### To stop the engine in an emergency:

1. Push the STOP button on the control panel. This will stop the unit with or without the ignition key or remote.

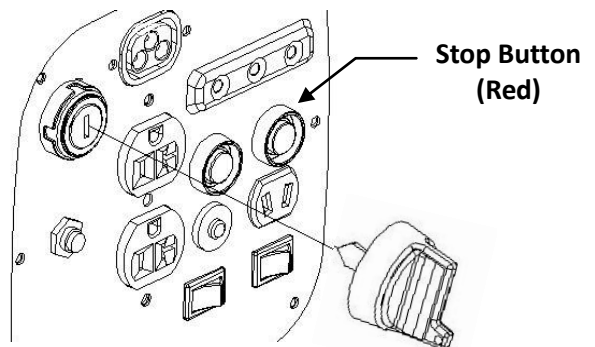

### Normal Shutdown

1. Turn off the connected equipment and disconnect from the generator.
2. If the remote control switch is “OFF”, turn the ignition switch to the OFF position.
3. If the remote control switch is “ON”, push and hold the stop button on the remote or the stop button on the control panel until the engine stops.



### WARNING

- Continually stopping the generator with a load applied can lead to damage of the control module.



### CAUTION

- Always put the remote switch in the “OFF” position when not in use, to prevent running down the battery.



## 5. PARALLEL GENERATOR OPERATION (with optional kit #69276)

### 5.1 Parallel operating features

1. Two separate PH2100PRi models can run in parallel to increase the total output to a maximum load of 4200 W (4000 W continual output).
2. You can also run a PH2100PRi and a PH2700PRi in parallel. The maximum output is 4200 W (4000 W continual output).

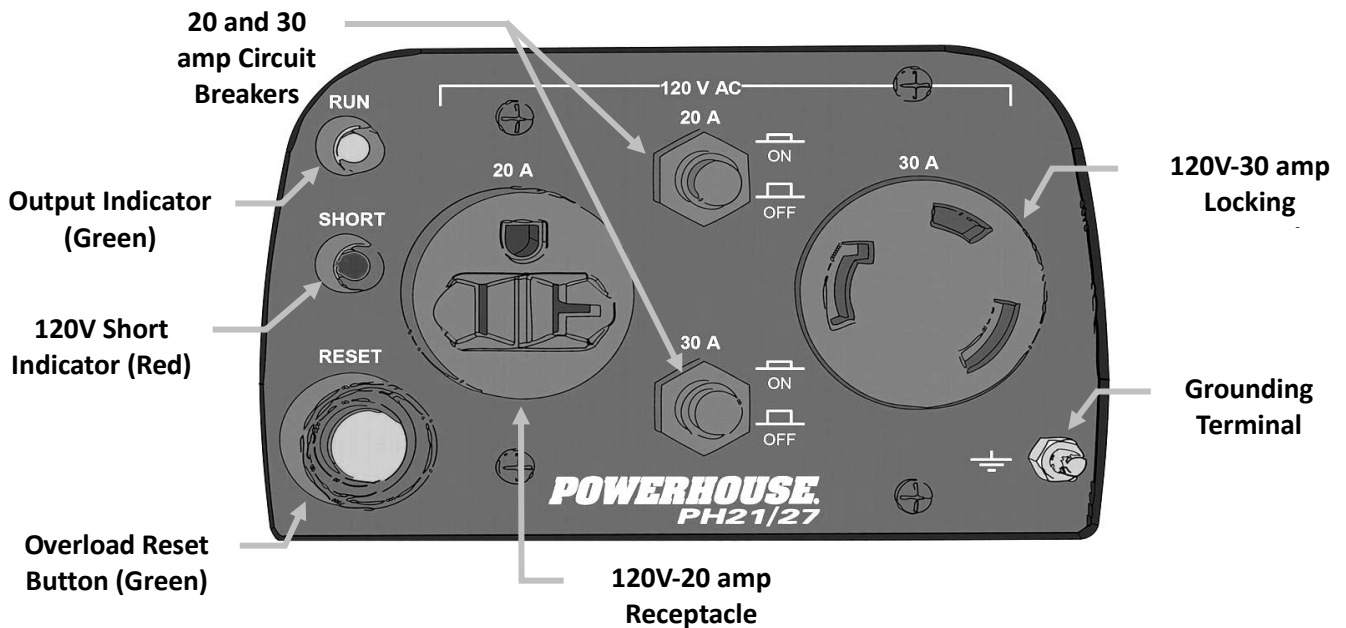
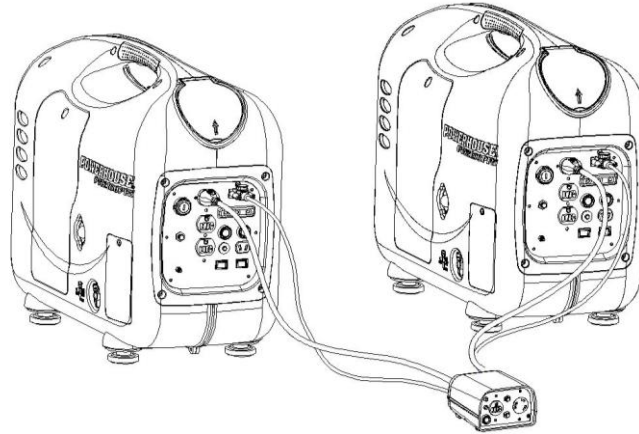

### 5.2 Air Conditioning Operation (13,500-15,000 btu)

When using two PH2100PRi models in parallel, bring the generators up to normal operating temperatures before applying the air conditioning load. Always allow a 2 minute wait period when manually cycling an air conditioner off and on. A longer wait period may be required under unusually hot weather conditions. Additionally, all other loads should be turned off until the air conditioner has started and is performing normally. It is also important to follow the air conditioner manufacturer's instructions for starting and restarting for proper operation.

---

## 6. MAINTENANCE

---

The purpose of the maintenance and adjustment schedule is to keep the generator in the best operating condition.

Inspect or service as scheduled in the table below.



- Shut off the engine before performing any maintenance. If the engine must be run, make sure the area is well ventilated. The exhaust contains poisonous carbon monoxide gas.



- Use genuine Powerhouse parts or their equivalent. The use of replacement parts which are not of equivalent quality may damage the generator.
- When repairing or replacing the accessories of emission control system, make sure to use the EPA standard accessories.

### 6.1 Emission control system

#### Emission source

Exhaust gas contains carbon monoxide, nitrogen oxides (NO<sub>x</sub>), and hydrocarbons. It is very important to control the emissions of NO<sub>x</sub> and hydrocarbons as they are a major contributor to air pollution. Carbon monoxide is a poisonous gas. The emission of fuel vapors is a source of pollution as well. The POWERHOUSE® generator engine utilizes a precise air-fuel ratio and emission control system to reduce the emissions of carbon monoxide, NO<sub>x</sub>, hydrocarbons, and evaporative fuel emissions.

#### Regulation

Your engine has been designed to meet current Environmental Protection Agency (EPA) and the California Air Resources Board (CARB) clean air standards. The regulations dictate that the manufacturer provides operation and maintenance standards regarding the emission control system. Tune up specifications are provided in the Specifications section and a description of the emission control system may be found in the appendix to this manual. Adherence to the following instructions will ensure your engine meets the emission control standards.

#### Modification

Modification of the emission control system may lead to increased emissions. Modification is defined as the following:

- Disassembling or modifying the function or parts of the intake, fuel, or exhaust system.
- Modifying or destroying the speed governing function of the generator.

## Engine faults that may affect emission

Any of the following faults must be repaired immediately. Consult with your authorized POWERHOUSE® service center for diagnosis and repair:

- Hard starting or shut down after starting
- Unstable idle speed
- Shut down or backfire after applying an electrical load
- Backfire.
- Black smoke and/or excessive fuel consumption

## Replacement parts and accessories

The parts making up the emission control system applied to POWERHOUSE® engine have been specifically approved and certified by the regulatory agencies. You can trust the replacement parts supplied by POWERHOUSE® have been manufactured to the same production standard as the original parts. The use of replacement parts or accessories which are not designed by POWERHOUSE® may affect the engine emission performance. The manufacturers of replacement parts and accessories have the responsibility to guarantee that their replacement products will not adversely affect emission performance.

## Maintenance

Maintain the generator according to the maintenance schedule in this section. Service items more frequently when used in dusty areas, or under conditions of high load, temperature, and humidity.

## Air Quality Index (only for California certified models)

CARB requires that an air quality index label be attached to every certified engine showing the engine emission information for the emission duration period. The label is provided for the user to compare the emission performance of different engines. The lower the air index, the better the engine emission performance. The description of durability is helpful for the user to learn the engine emission duration period and the service life of emission control system. Refer to the warranty section of this owner's manual for more information.

The air quality index label is designed to be permanently affixed to the generator and removal should not be attempted.

**IMPORTANT EMISSIONS INFORMATION**  
YONGKANG XINGGUANG ELECTRICAL MANUFACTURE CO., LTD.

THIS ENGINE IS CERTIFIED TO OPERATE ON UNLEADED GASOLINE. THIS ENGINE CONFORMS TO U.S. EPA REGS FOR [2010]. MEETS 2010 CALIFORNIA EXH AND EVP EMISSION REGULATIONS FOR SI SORE. ENGINE FAMILY: AYKXS.1251XG  
LUBRICANT REQUIREMENTS: SF15W-40 ENGINE DISPLACEMENT: 125 cc  
EXHAUST ECS:TWC+PAIR EVAP FAMILY/ECS: CM MANUFACTURE DATE:

THE AIR INDEX OF THIS ENGINE IS 3

MOST CLEAN 0 2 4 6 8 10 LEAST CLEAN

THIS ENGINE IS CERTIFIED TO BE EMISSIONS COMPLIANT FOR THE FOLLOWING USE:  
MODERATE (125 HOURS)  INTERMEDIATE (250 HOURS)  EXTENDED (500 HOURS)

REFER TO OWNER'S MANUAL FOR MAINTENANCE SPECIFICATIONS AND ADJUSTMENTS.

## 6.2 Maintenance Schedule

Item	Maintenance Procedure	Regular Service period (1). Perform at every indicated month or operating hour interval, whichever occurs first.				
		Each Use	1 <sup>st</sup> Month or 20 Hours	Every 3 Months or 50 Hours	Every 6 Months or 100 Hours	1x per Year Or 300 Hours
Engine Oil	Check	0				
	Change		0		0	
Air cleaner	Check	0				
	Clean			0 (2)		
Spark Plug	Clean / Adjust				0	
Spark Arrester	Clean				0	
Fuel Filter	Check	0				
	Replace					0 (2)
Valve clearance	Check / Adjust					0 (3)
Fuel tank & strainer	Clean					0 (2)
Fuel line	Check	Every 2-years (Replace as necessary) (3)				



### NOTE

(1) Log hours of operation to determine proper maintenance.

(2) Service more frequently when used in dusty areas.

(3) These items should be serviced by an authorized dealer unless the owner has the proper tools and is mechanically proficient. See the shop Manual.

Service Period for Oil Changes	Temperature
Normal –100 hr	77°F (25°C)
95 hr	86°F (30°C)
85 hr	95°F (35°C)
70 hr	104°F (40°C)

## 6.3 Changing oil

Drain the oil while the engine is still warm to assure rapid and complete draining.

### CAUTION

- Make sure to turn the engine switch and the fuel cap vent lever OFF before draining.

1. Loosen the cover screw and remove the side maintenance cover.
2. Remove the oil filler cap.
3. Install the oil drain pipe.
4. Drain dirty oil into a container thoroughly.
5. Refill with the recommended oil, and check the oil level.
6. Reinstall the maintenance cover and tighten the screw securely.

Engine oil capacity: 15.2 oz. (0.45L)

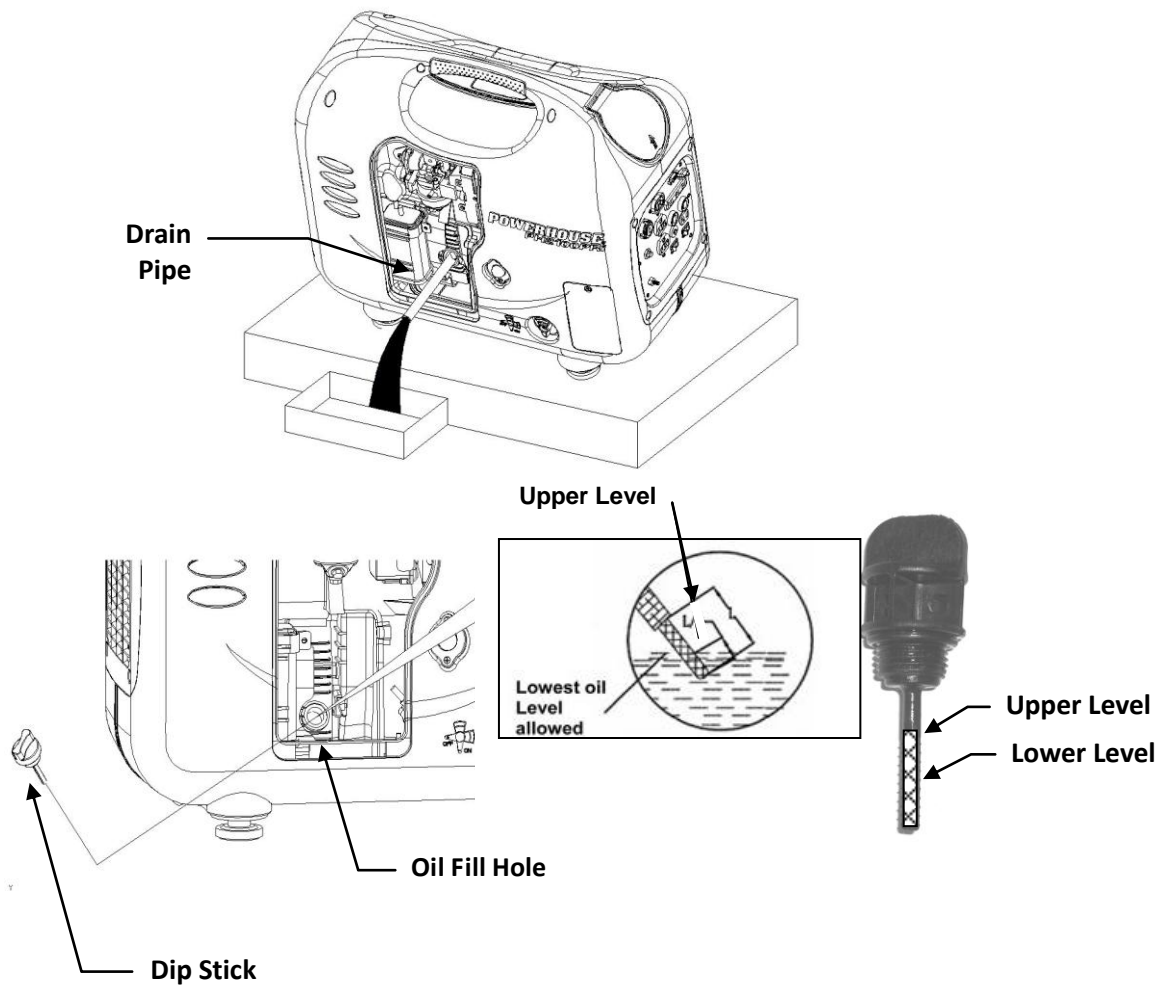

### NOTE

- Please dispose of used motor oil in a manner that is compatible with the environment and local disposal regulations. Do not throw it in the trash or pour it on the ground.

## 6.4 Air cleaner service

A dirty air cleaner will restrict air flow to the carburetor. To prevent carburetor malfunction, service the air cleaner regularly. Service more frequently when operating the generator in extremely dirty areas.

**⚠ WARNING** ■ Do not use gasoline or low flash point solvents for cleaning. They are flammable and explosive under certain conditions.

**⚠ CAUTION** ■ Never run the generator without the air cleaner, otherwise rapid engine wear may result.

1. Loosen the panel screw and remove the side maintenance panel.
2. Remove three air filter retaining screws. Remove the air assembly and check the element. Clean or replace the element if necessary.
3. Wash the element in a non-flammable or high flash point solvent and dry it thoroughly.
4. Soak element in clean engine oil and squeeze out the excess oil.
5. Reinstall the air cleaner element and the air cleaner cover. Tighten the cover screws securely.
6. Reinstall the maintenance panel and tighten the screw securely.

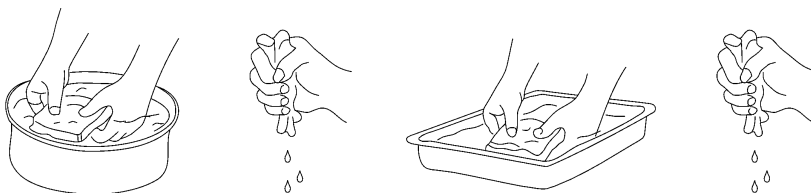
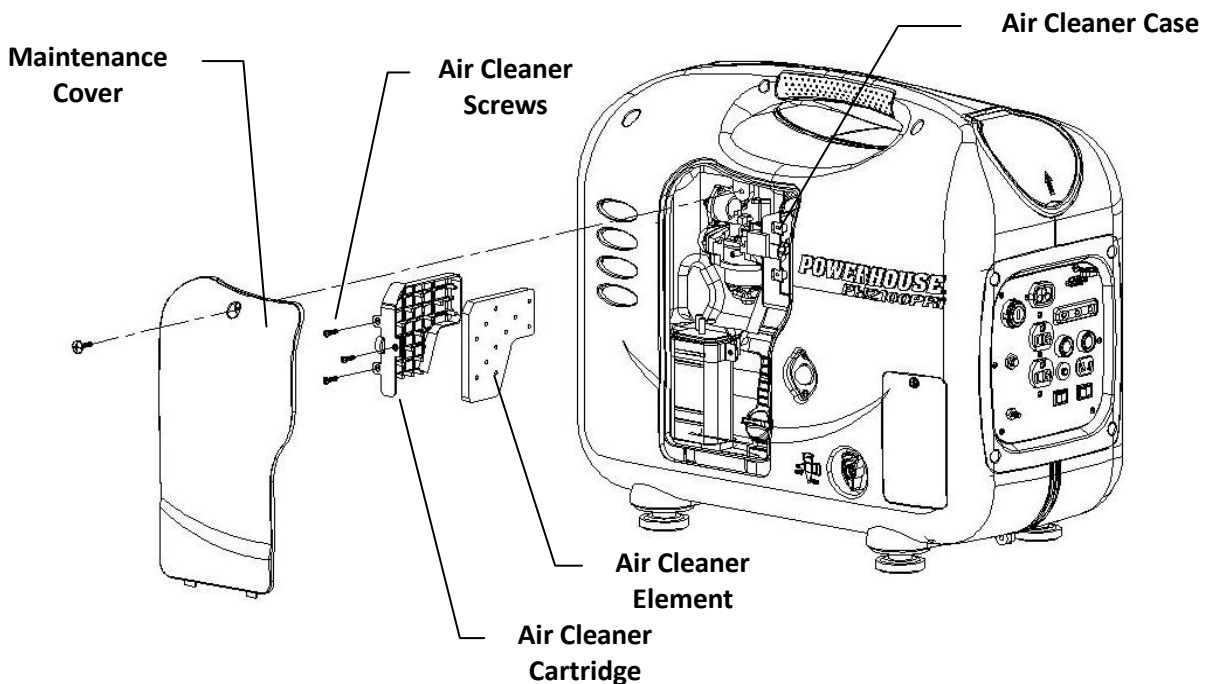

## 6.5 Spark plug maintenance

RECOMMENDED SPARK PLUG: A7RTC

To ensure proper engine operation, the spark plug must be properly gapped and free of deposits.

1. Loosen the cover screw and remove the spark plug maintenance cover.

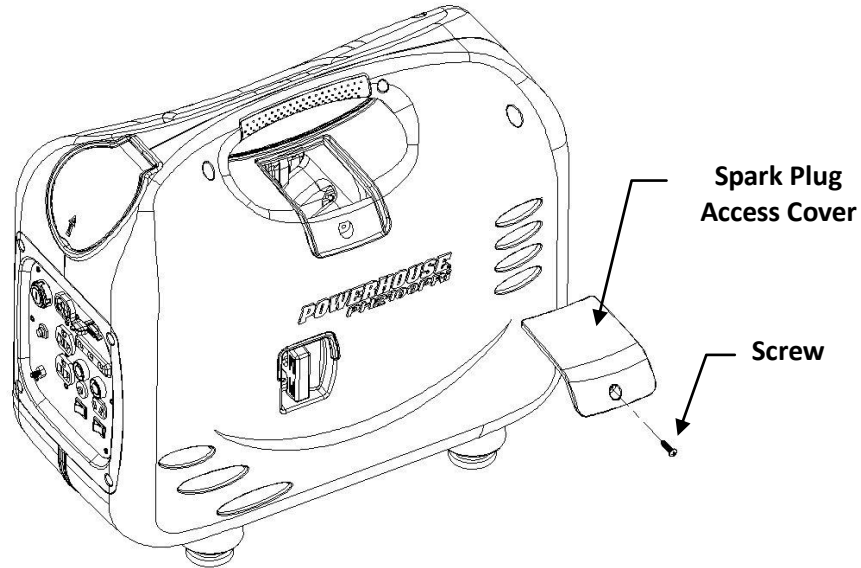

2. Remove the spark plug cap.
3. Clean any dirt from around the spark plug base.
4. Use the supplied wrench to remove the spark plug.

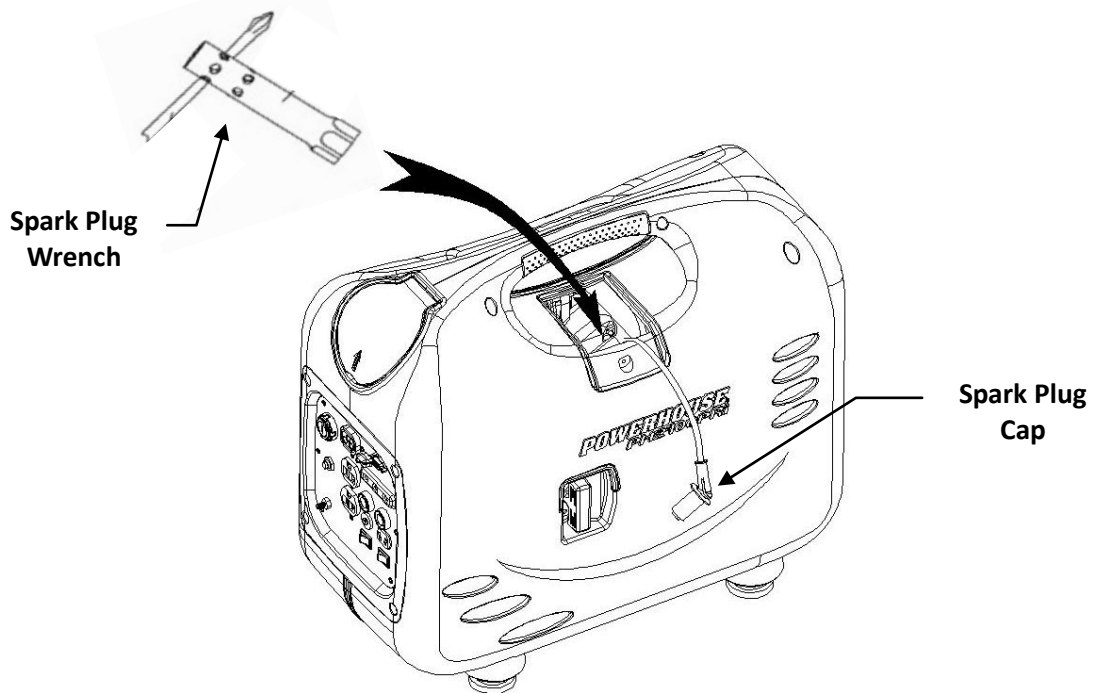

5. Visually inspect the spark plug. Discard it if the insulator is cracked or chipped.  
Clean the spark plug with a wire brush if it is to be reused.
6. Measure the plug gap with a feeler gauge.
7. The gap should be 0.024-0.028in (0.6-0.7mm). Correct as necessary by carefully bending the side electrode.

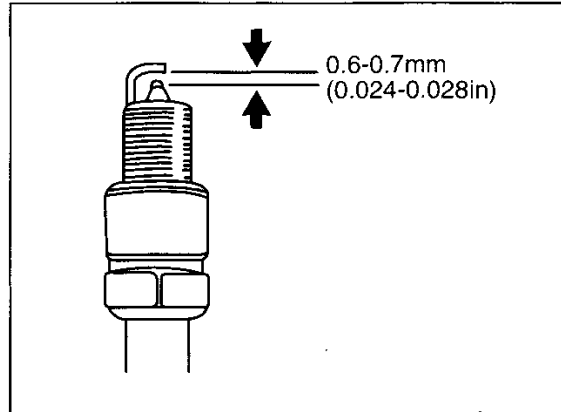

8. Install the spark plug carefully, by hand, to avoid cross-threading.
9. After a new spark plug has been seated by hand, it should be tightened 1/2 turn with a wrench to compress its washer. If a used plug is being reinstalled, it should only require 1/8 to 1/4 turn after being seated.
10. Reinstall the spark plug cap on the spark plug securely.
11. Reinstall the spark plug maintenance cover.

**⚠ CAUTION**

- The spark plug must be securely tightened. An improperly tightened plug can become very hot and possibly damage the generator.
- Never use a spark plug with an improper heat range.
- Never use a spark plug without damping resistance or it will cause no AC output.

## 6.6 Spark arrestor maintenance

### CAUTION

- If the generator has been running, the muffler will be very hot. Allow it to cool before proceeding.

### NOTE

- The spark arrestor must be serviced every 100 hours to maintain its efficiency.

1. Remove the four M6 screws and remove the muffler grill.
2. Remove the two M4 screws holding the spark arrestor to the muffler.
3. Use a stiff wire brush to remove carbon deposits from the spark arrestor screen.
4. Inspect the screen for holes, and replace it if necessary.

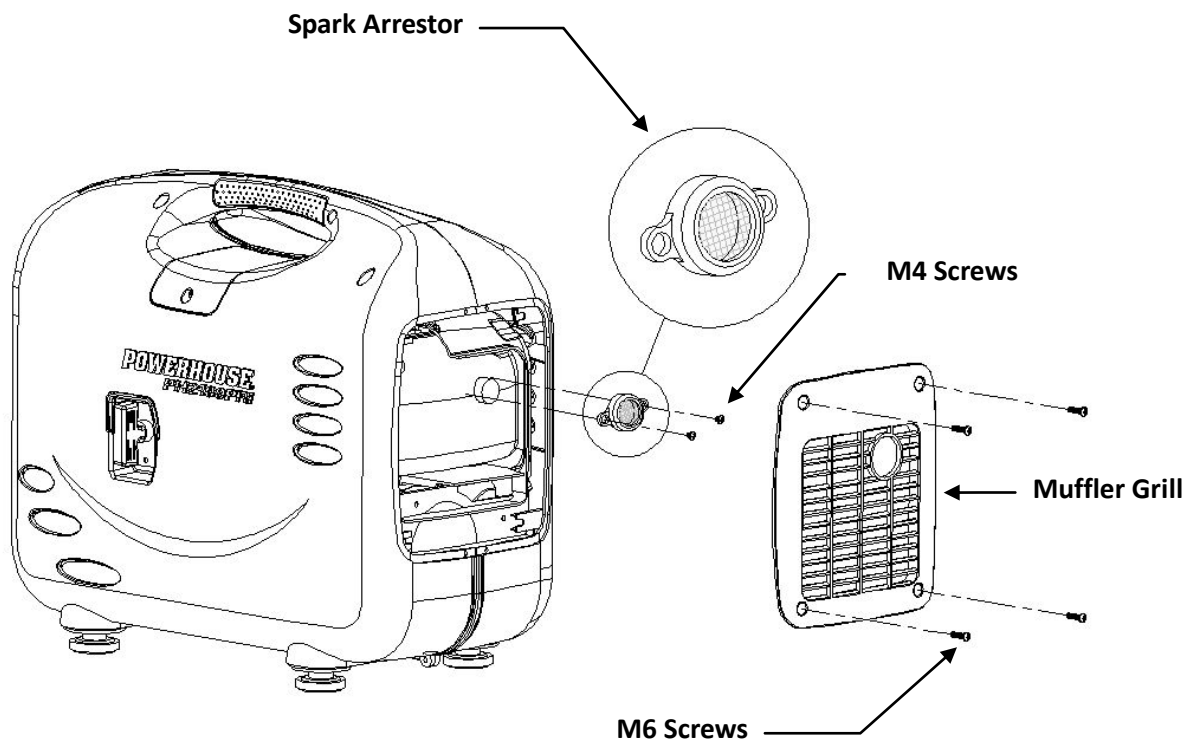

## 7. TRANSPORTING and STORAGE

---

To prevent fuel spillage when transporting or during temporary storage, the generator should be secured upright in its normal operating position with the fuel valve and ignition switch turned OFF.

When transporting the generator:



- Do not overfill the tank.
- Do not operate the generator while it is on or in a vehicle.
- Always run the generator in a well ventilated area.
- Avoid placing the generator in direct sunlight when storing. If the generator is left in an enclosed area or vehicle, high temperature inside could cause residual fuel to vaporize resulting in a possible explosion.
- **If you must transport the generator in a vehicle, drain all fuel from the generator.**

### 7.1 Exercising the Generator

It is essential that the generator be exercised on a regular basis. This will prevent the accumulation of varnish or sludge in the fuel system; remove moisture from the generator windings and help keep the battery properly charged. Additionally the engine seals and moving components will be lubricated. Exercise the generator by running it with at least a 1/2 load (1000W) for 60 minutes per month. Gasoline fuel treatments to prevent contamination of your fuel supply are available from your dealer. Fuel varnishing necessitating replacement of the carburetor is not a warrantable failure.

## 7.2 Before storing the unit for an extended period

1. Be sure the storage area is free of excessive humidity and dust.
2. Regardless of whether you plan to store your generator with or without fuel, add an appropriate amount (per the instructions on the bottle) of fuel stabilizer and run the generator for 5 minutes. This will assure that any fuel trapped in the system will have the stabilizer in it. If you do not drain the fuel, it is best to keep the tank full, as it will be less likely to form condensation in the fuel tank. You may also opt to add the fuel stabilizer and run the unit until it is out of fuel. If you opt to drain the fuel, then continue on with the instructions below.

### **WARNING**

- Gasoline is extremely flammable and explosive under certain conditions.
  - Do not smoke or allow flames or sparks in the area.
3. To drain the gasoline from the fuel tank, turn the engine switch to the OFF position.
  4. Attach a hose to the drain fitting on the carburetor and place the other end of the hose into an approved gasoline container.
  5. Turn the fuel valve ON, and loosen the carburetor drain screw and drain the gasoline into the approved gasoline container.
  6. After the fuel tank has been drained, with the drain screw loosened, disconnect the spark plug wire and pull the starter grip 3 to 4 times to drain the gasoline from the fuel pump.
  7. Turn the fuel valve to the OFF position, and tighten the drain screw securely.
  8. Change the engine oil.
  9. Remove the spark plug and pour about a tablespoon of clean engine oil into the cylinder.
  10. Crank the engine several revolutions to distribute the oil and then reinstall the spark plug.
  11. Slowly pull the starter grip until resistance is felt. At this point, the piston is coming up on its compression stroke and both the intake and exhaust valves are closed. Storing the engine in this position will help to protect it from internal corrosion.
  12. Turn the remote switch to the “OFF” position to prevent unwanted, unintentional cranking.
  13. Once a month, recharge the battery.

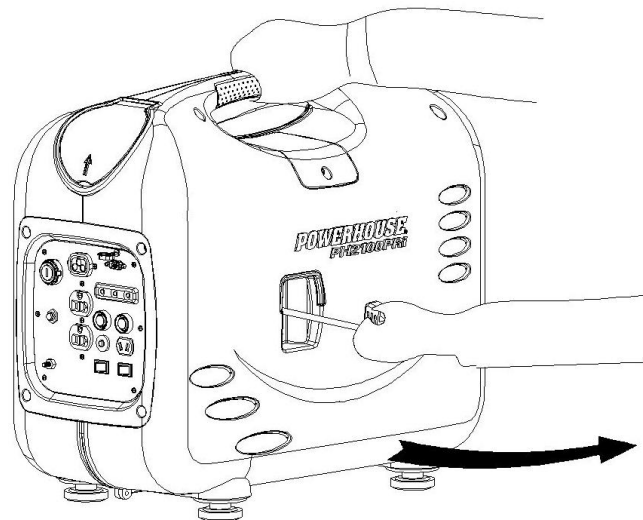

# 8. TROUBLESHOOTING

## 8.1 Engine will not start:

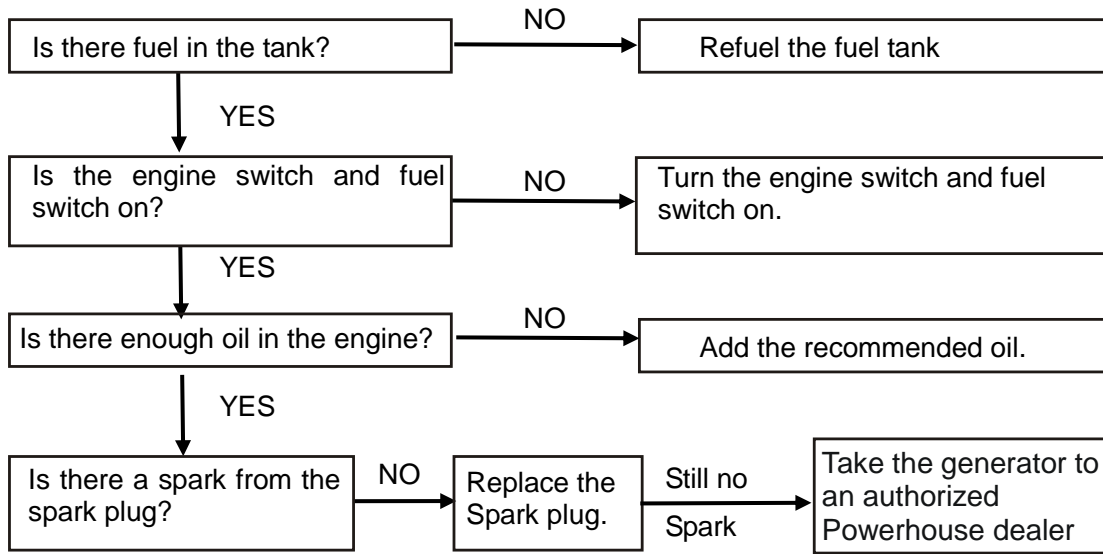

**WARNING**

- Be sure there is no spilled fuel around the spark plug.
- Spilled fuel may ignite.

If the engine still does not start, take it to an authorized Powerhouse dealer

- To check spark:
1. Remove the spark plug cap and clean any dirt from around the spark plug.
  2. Remove the spark plug and install the spark plug in the plug cap.
  3. Attach the plug side electrode to your ground wire.
  4. Pull the recoil starter, sparks should jump across the gap

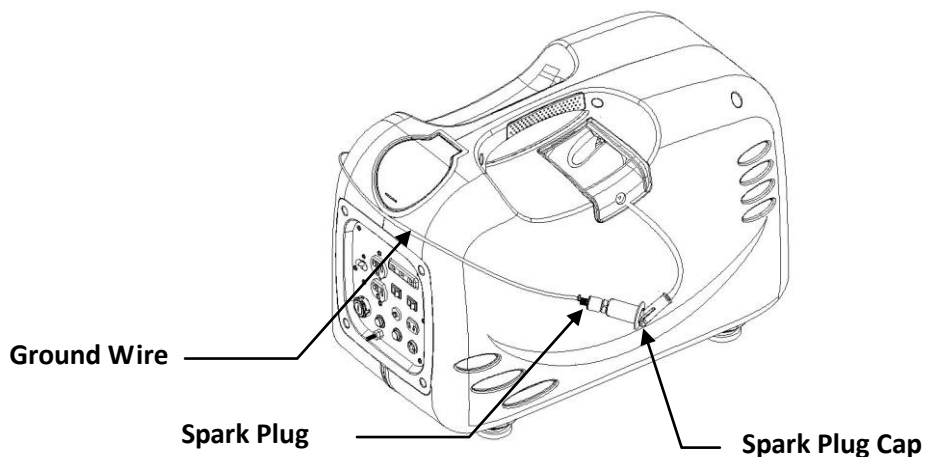

### 8.2 Appliance does not operate:

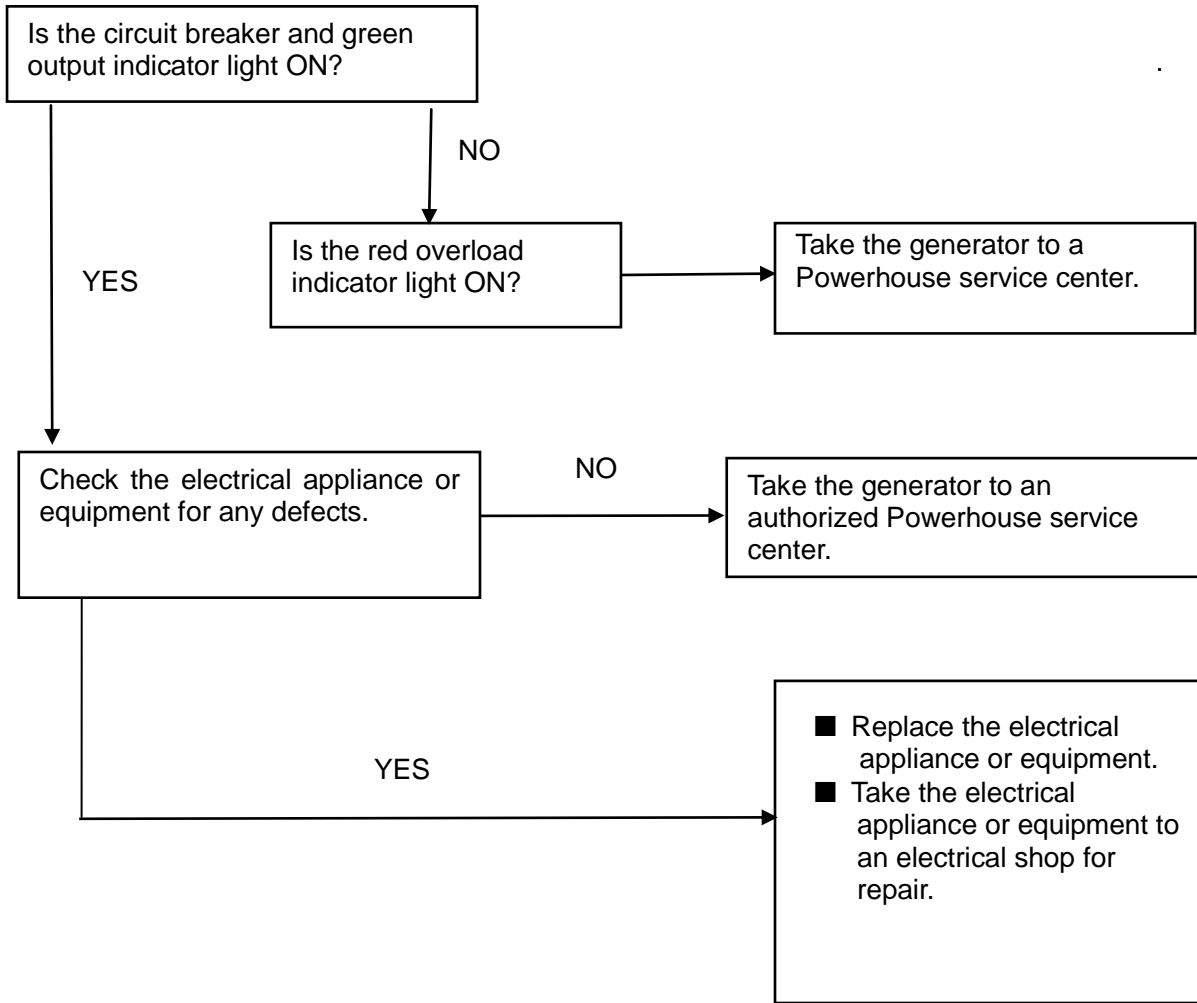

### 8.3 No output at the DC receptacle:

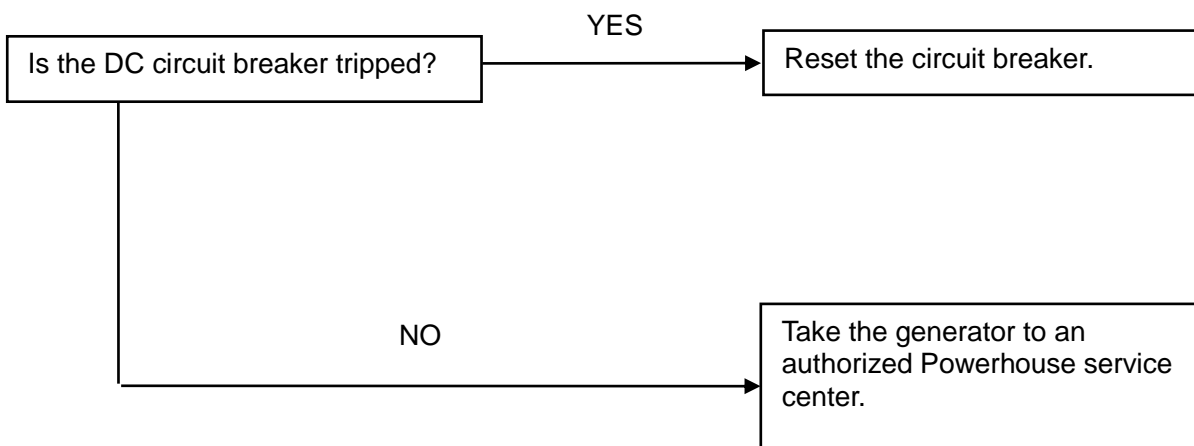

## 9. SPECIFICATIONS

### Generator

Model	PH2100PRi
Rated frequency (Hz)	60
Rated voltage (V)	120
Rated current (A) (Parallel)	16.7 (33.3)
Max current (A) (Parallel)	17.5 (35)
Rated output (W) (Parallel)	2000 (4000)
Max output (W) (Parallel)	2100 (4200)
DC Output	12 V, 8.3 A
Phase	Single

### Engine

Model	XG-152F
Type	4 stroke, vertical shaft, air-cooled, OHC, gasoline engine
Displacement	125 cc
Compression ratio	9.2:1
Engine speed	5000 RPM with economy switch off
Ignition system	Electronic
Spark plug	A7RTC
Starting system	Remote, Electric & Recoil
Fuel	Automotive unleaded gasoline
Lube oil	SAE 15W40 (above CD grade)
Oil Capacity	15.2 oz. (0.45 L)
Fuel tank capacity	1.3 gal (5.0 L)
Continuous running time at ¼ and Continual load	3.0 ~ 7.5 hours
Noise level (no load ~ full load) dB@ 23' (7m)	56 ~ 66 dB

**Tune Up Specifications**

Spark Plug Gap	0.024-0.028 in (0.6-0.7 mm)
Valve Clearance (Intake)	0.0039±0.0008 in (0.10±0.02mm)
Valve Clearance (Exhaust)	0.0059±0.0008 in (0.15±0.02mm)

**Dimensions**

Overall dimension (LxWxH) in (mm)	22 X 11 X 19 in (559 x 279 x 482 mm)
Dry weight with battery	73 lbs. (33kg)

---

## 10. WARRANTY AND CONSUMER INFORMATION

---

### POWERHOUSE® GENERATOR WARRANTY

Generators are covered by this warranty from the date of original retail purchase for a period of 2 years for residential use and 1 year for commercial applications. Units used in rental fleets, reconditioned or as demonstration models will be considered commercial usage. Batteries that are supplied with applicable products as standard, original equipment will be covered for a period of one year. The warranty coverage is continual from the original date of purchase, and does not restart upon the replacement of any part or complete unit. Individual parts replaced at any point during the warranty period are only eligible for warranty coverage for the balance of the original warranty period.

#### Eligibility

To be eligible for warranty replacement, the product must be purchased in the United States or Canada from an authorized Coast Distribution dealer. This warranty applies to the original retail purchaser only, and is not transferable. Proof of purchase and the serial number is required.

#### Coverage

Pre-approved parts and labor costs will be covered by POWERHOUSE® for any failure that is proven to be a failure in material or workmanship under normal use during the applicable warranty time period. This coverage is limited to parts, labor and ground shipping of repair parts. It is the responsibility of the end user to return the product to the nearest authorized repair center as directed by the warranty administration center. If in the event that the generator is deemed to be not repairable or the necessary repair would be economically unfeasible, the warranty department will authorize its prepaid return to the nearest Coast location and Coast will prepay the returned shipping to the dealer, repair center or consumer. Coast Distribution reserves the right to repair or replace any part or unit at its option. Coast Distribution may request defective parts to be returned. Anything replaced under warranty becomes the property of Coast Distribution.

#### To Obtain Warranty Service

Contact any authorized dealer or contact our national customer service center at:

Phone: 1-877-544-4449

Fax: 1-800-263-0280

E-mail: [www.powerhouse-products.com](http://www.powerhouse-products.com)

If contacting us by fax or e-mail, be sure to include a description of the problem as well as all return contact info such as address, phone number, fax number, e-mail, etc. Engine serial number and proof of purchase is required.

#### Exclusions

THIS WARRANTY DOES NOT EXTEND TO PARTS AFFECTED OR DAMAGED BY ACCIDENT AND/OR COLLISION, NORMAL WEAR, FUEL CONTAMINATION OR DEGRADATION, USE IN AN APPLICATION FOR WHICH THE PRODUCT WAS NOT DESIGNED OR ANY OTHER MISUSE, NEGLIGENCE, INCORPORATION OR USE OF UNSUITABLE ATTACHMENTS OR PARTS, UNAUTHORIZED ALTERATION, OR ANY CAUSES OTHER THAN DEFECTS IN MATERIAL OR WORKMANSHIP OF THE PRODUCT. THIS WARRANTY DOES NOT EXTEND TO NORMAL MAINTENANCE ITEMS SUCH AS BELTS, HOSES, SPARK PLUGS, WHEELS AND FILTERS PAST THE FIRST SCHEDULED REPLACEMENT OR SERVICE INTERVAL FOR THESE ITEMS WHICHEVER COMES FIRST.

#### Disclaimer of Consequential Damage and Limitation of Implied Warranties

COAST DISTRIBUTION DENIES ANY RESPONSIBILITY FOR LOSS OF TIME OR USE OF THE PRODUCT, TRANSPORTATION, COMMERCIAL LOSS, OR ANY OTHER INCIDENTAL OR CONSEQUENTIAL DAMAGE. ANY IMPLIED WARRANTIES ARE LIMITED TO THE DURATION OF THIS WRITTEN LIMITED WARRANTY.

Some states do not allow limitations on how long an implied warranty lasts and/or do not allow the exclusion or limitation of incidental or consequential damages. Therefore, the above exclusions and limitations may not apply to you. This warranty gives you specific legal rights, and you may also have other rights, which vary from state to state.

#### Replacement Parts Availability

To purchase replacement parts please refer to the [www.powerhouse-products.com](http://www.powerhouse-products.com) website

## **CALIFORNIA EMISSIONS CONTROL WARRANTY STATEMENT**

### **Your Warranty Rights and Obligations**

The California Air Resources Board and Coast Distribution System Inc. (POWERHOUSE®) are pleased to explain the emissions control system warranty on your 2008 and later small off-road engine (SORE). In California, new SOREs must be designed, built, and equipped to meet the State's stringent anti-smog standards. Coast Distribution System Inc. (POWERHOUSE®) must warrant the emissions control system on your SOREs for the periods of time listed below provided there has been no abuse, neglect or improper maintenance of your SOREs.

Your emission control system may include parts such as the carburetor, fuel tanks, fuel caps, fuel lines, the ignition system, and catalytic converter. Also included may be hoses, belts, clamps, connectors and other emission-related assemblies.

Where a warrantable condition exists, Coast Distribution System Inc. will repair your small off-road engine at no cost to you including diagnosis, parts, and labor.

### **Manufacturer's Warranty Coverage**

The emissions control system is warranted for two years. If any emissions-related part on your engine is defective, the part will be repaired or replaced by Coast Distribution System Inc.

### **Owner's Warranty Responsibilities**

- As the SORE owner, you are responsible for the performance of the required maintenance listed in your owner's manual. Coast Distribution System Inc. recommends that you retain all receipts covering maintenance on your SORE, but Coast Distribution System Inc. (POWERHOUSE®) cannot deny warranty solely for the lack of receipts or for your failure to ensure the performance of all scheduled maintenance.
- As the SORE owner, you should however be aware that Coast Distribution System Inc. may deny your warranty coverage if your SORE or a part has failed due to abuse, neglect, improper maintenance or unapproved modifications.
- You are responsible for presenting your SORE to distribution center or service center authorized by Coast Distribution System Inc. (Powerhouse®) as soon as the problem exists. The warranty repairs should be completed in a reasonable amount of time, not to exceed 30 days.

If you have any questions regarding your warranty coverage, you should contact the North America service center for Powerhouse® products:

Phone: 1-877-544-4449

Fax: 1-800-263-0280

E-mail: [www.powerhouse-products.com](http://www.powerhouse-products.com)

## **EMISSION CONTROL SYSTEM WARRANTY**

Your POWERHOUSE® generator engine complies with U.S. Environmental Protection Agency, Environment of Canada, and the state of California (if the model is certified by CARB). The following systems and/or parts are covered by this warranty. Failures or improper operation of the following systems and components will be diagnosed and repaired with no charge for labor or parts.

### **Fuel System**

- Carburetor including the choke system and replaceable high altitude main jets
- Engine speed control system (Economy Throttle)
- Intake manifold
- Engine control module

### **Evaporative Control System**

- Fuel tank
- Fuel cap
- Fuel strainer
- Fuel valve
- Fuel pump
- Fuel lines
- Carbon canister (including brackets and connectors)

### **Air Induction System**

- Air filter element\*
- Air filter housing

### **Ignition system**

- Ignition module
- Ignition coil
- Ignition winding
- Spark plug\*
- Spark plug cap and wire

### **Exhaust system**

- Catalyst
- Exhaust manifold
- Secondary air injection assembly

### **Miscellaneous**

- Pipes, tubes, hoses and clamps, o-rings, seals, and gaskets associated with the above systems.

\* Covered up to the first scheduled replacement only. See the maintenance schedule.

---

## 11. APENDIX B - EMISSION CONTROL SYSTEM

---

Your generator has an engine that has been approved by the California Air Resources Board. Other than the tune up procedures specified in the maintenance section, no additional maintenance is required.

The emission control system has the following components:

1. Fuel System: The fuel tank, cap, indicator and hoses are specially designed and constructed to not allow fuel vapors to permeate and be released to the atmosphere.
2. A carbon activated canister collects gasoline vapors from the fuel tank and returns them to the combustion chamber for burning.
3. A catalyst is built into the muffler to further treat the engine exhaust.
4. A secondary air injection valve adds combustion air to ignite unburned fuel in the exhaust.

Contact your authorized POWERHOUSE® service center to obtain the correct replacement parts and service on this system.

---

## 12. APENDIX C - SAFETY AND CHARGING INSTRUCTIONS

---

- (a) SAVE THESE INSTRUCTIONS. THIS MANUAL CONTAINS IMPORTANT SAFETY AND OPERATING INSTRUCTIONS.
- (b) WORKING IN THE VICINITY OF A LEAD-ACID BATTERY IS DANGEROUS. BATTERIES GENERATE EXPLOSIVE GASES DURING NORMAL BATTERY OPERATION. FOR THIS REASON IT IS OF THE UTMOST IMPORTANCE THAT EACH TIME BEFORE USING YOUR CHARGER, YOU READ AND FOLLOW THE INSTRUCTIONS PROVIDED EXACTLY.
- (c) TO REDUCE RISK OF BATTERY EXPLOSION, FOLLOW THESE INSTRUCTIONS AND THOSE MARKED ON THE BATTERY.
- (d) NEVER SMOKE OR ALLOW AN OPEN SPARK OR FLAME IN THE VICINITY OF THE BATTERY OR ENGINE.
- (e) USE CHARGER FOR CHARGING A LEAD-ACID BATTERY ONLY. IT IS NOT INTENDED TO SUPPLY POWER TO AN EXTRA-LOW-VOLTAGE ELECTRICAL SYSTEM OR TO CHARGE DRY-CELL BATTERIES. CHARGING DRY-CELL BATTERIES MAY CAUSE THEM TO BURST AND CAUSE INJURY TO PERSONS AND DAMAGE TO PROPERTY.
- (f) NEVER CHARGE A FROZEN BATTERY.
- (g) IF IT IS NECESSARY TO REMOVE BATTERY FROM VEHICLE TO CHARGE IT, ALWAYS REMOVE GROUNDED TERMINAL FROM BATTERY FIRST. MAKE SURE ALL ACCESSORIES IN THE VEHICLE ARE OFF IN ORDER TO PREVENT AN ARC.
- (h) STUDY ALL BATTERY MANUFACTURER'S SPECIFIC PRECAUTIONS SUCH AS REMOVING OR NOT REMOVING CELL CAPS WHILE CHARGING AND RECOMMENDED RATES OF CHARGE.
- (i) FOR A CHARGER HAVING AN OUTPUT VOLTAGE SELECTOR SWITCH, REFER TO THE CAR OWNER'S MANUAL IN ORDER TO DETERMINE THE VOLTAGE OF THE BATTERY AND TO MAKE SURE THE OUTPUT VOLTAGE IS SET AT THE CORRECT VOLTAGE. IF AN OUTPUT VOLTAGE SELECTOR SWITCH IS NOT PROVIDED, DO NOT USE THE BATTERY CHARGER UNLESS THE BATTERY VOLTAGE MATCHES THE OUTPUT VOLTAGE RATING OF THE CHARGER.
- (j) NEVER PLACE THE CHARGER DIRECTLY ABOVE OR BELOW THE BATTERY BEING CHARGED; GASES OR FLUIDS FROM THE BATTERY WILL CORRODE AND DAMAGE THE CHARGER. LOCATE THE CHARGER AS FAR AWAY FROM THE BATTERY AS DC CABLES PERMIT.
- (k) DO NOT OPERATE CHARGER IN A CLOSED-IN AREA OR RESTRICT VENTILATION IN ANY WAY.
- (l) CONNECT AND DISCONNECT DC OUTPUT CLIPS ONLY AFTER SETTING ANY CHARGER SWITCHES TO THE OFF POSITION AND REMOVING AC CORD FROM THE ELECTRIC OUTLET. NEVER ALLOW CLIPS TO TOUCH EACH OTHER.
- (m) FOLLOW THESE STEPS WHEN BATTERY IS INSTALLED IN VEHICLE. A SPARK NEAR BATTERY MAY CAUSE A BATTERY EXPLOSION. TO REDUCE RISK OF A SPARK NEAR BATTERY:
  - i. POSITION AC AND DC CORDS TO REDUCE RISK OF DAMAGE BY HOOD, DOOR, OR MOVING ENGINE PARTS;
  - ii. STAY CLEAR OF FAN BLADES, BELTS, PULLEYS, AND OTHER PARTS THAT CAN CAUSE INJURY TO PERSONS;
  - iii. CHECK POLARITY OF BATTERY POSTS. A POSITIVE (POS, P, +) BATTERY POST USUALLY HAS A LARGER DIAMETER THAN A NEGATIVE (NEG, N, -) POST;
  - iv. DETERMINE WHICH POST OF BATTERY IS GROUNDED (CONNECTED) TO THE CHASSIS. IF NEGATIVE POST IS GROUNDED TO CHASSIS (AS IN MOST VEHICLES), SEE ITEM (v). IF POSITIVE POST IS GROUNDED TO THE CHASSIS, SEE ITEM (vi);

- v. FOR A NEGATIVE-GROUNDED VEHICLE, CONNECT THE POSITIVE (RED) CLIP FROM BATTERY CHARGER TO POSITIVE (POS, P, +) UNGROUNDED POST OF BATTERY. CONNECT THE NEGATIVE (BLACK) CLIP TO VEHICLE CHASSIS OR ENGINE BLOCK AWAY FROM BATTERY. DO NOT CONNECT CLIP TO CARBURETOR, FUEL LINES, OR SHEET-METAL BODY PARTS. CONNECT TO A HEAVY GAUGE METAL PART OF THE FRAME OR ENGINE BLOCK;
  - vi. FOR A POSITIVE-GROUNDED VEHICLE, CONNECT THE NEGATIVE (BLACK) CLIP FROM BATTERY CHARGER TO NEGATIVE (NEG, N, -) UNGROUNDED POST OF BATTERY. CONNECT THE POSITIVE (RED) CLIP TO VEHICLE CHASSIS OR ENGINE BLOCK AWAY FROM BATTERY. DO NOT CONNECT CLIP TO CARBURETOR, FUEL LINES, OR SHEET-METAL BODY PARTS. CONNECT TO A HEAVY GAUGE METAL PART OF THE FRAME OR ENGINE BLOCK;
  - vii. CONNECT CHARGER AC SUPPLY CORD TO ELECTRIC OUTLET; AND
  - viii. WHEN DISCONNECTING CHARGER, TURN SWITCHES TO OFF, DISCONNECT AC CORD, REMOVE CLIP FROM VEHICLE CHASSIS, AND THEN REMOVE CLIP FROM BATTERY TERMINAL.
- (n)** FOLLOW THESE STEPS WHEN BATTERY IS OUTSIDE VEHICLE. A SPARK NEAR THE BATTERY MAY CAUSE A BATTERY EXPLOSION. TO REDUCE RISK OF A SPARK NEAR BATTERY:
- i. CHECK POLARITY OF BATTERY POSTS. A POSITIVE (POS, P, +) BATTERY POST USUALLY HAS A LARGER DIAMETER THAN A NEGATIVE (NEG, N, -) POST;
  - ii. ATTACH AT LEAST A 60 CM 6-GAUGE (AWG) INSULATED BATTERY CABLE TO A NEGATIVE (NEG, N, -) BATTERY POST;
  - iii. CONNECT THE POSITIVE (RED) CHARGER CLIP TO THE POSITIVE (POS, P, +) POST OF BATTERY;
  - iv. POSITION YOURSELF AND THE FREE END OF CABLE AS FAR AWAY FROM BATTERY AS POSSIBLE, THEN CONNECT THE NEGATIVE (BLACK) CHARGER CLIP TO FREE END OF CABLE;
  - v. DO NOT FACE BATTERY WHEN MAKING FINAL CONNECTION;
  - vi. CONNECT CHARGER AC SUPPLY CORD TO ELECTRICAL OUTLET; AND
  - vii. WHEN DISCONNECTING CHARGER, ALWAYS DO SO IN REVERSE SEQUENCE OF CONNECTING PROCEDURE AND BREAK FIRST CONNECTION WHILE STANDING AS FAR AWAY FROM BATTERY AS PRACTICAL.
- (o)** USE OF AN ADAPTER IS NOT ALLOWED IN CANADA. IF A GROUNDING TYPE RECEPTACLE IS NOT AVAILABLE, DO NOT USE THIS APPLIANCE UNTIL THE PROPER OUTLET IS INSTALLED BY A QUALIFIED ELECTRICIAN.
- (p)** THE GENERATOR (STATOR WINDING) IS ISOLATED FROM THE FRAME AND FROM THE AC RECEPTACLE GROUND PIN.
- (q)** ELECTRICAL DEVICES THAT REQUIRE A GROUNDED RECEPTACLE PIN CONNECTION WILL NOT FUNCTION IF THE RECEPTACLE GROUND PIN IS NOT FUNCTIONAL.