

QuickStart Guide

Thank you

FOR JOINING THE
POWERHOUSE FAMILY

Please review this Quick Start Guide to begin using your generator.
To fully understand and safely operate this product, please review the
warnings and complete detailed instructions in the Owner's Manual.



**Please refer to the Owner's Manual
when you see this icon for important
details and additional information.**



Use outdoors only

PRODUCES CARBON MONOXIDE —
CAN CAUSE DEATH OR SERIOUS INJURY



Avoid water

KEEP AWAY FROM RAIN, SNOW
AND OTHER WET CONDITIONS



Flammable

KEEP AWAY FROM SMOKING MATERIALS,
SPARKS, + SOURCES OF COMBUSTION WHEN REFUELING



In emergency

PUSH THE ENGINE SWITCH TO **OFF** POSITION
TO STOP ENGINE – WITH OR WITHOUT A LOAD.



Keep level

ALWAYS OPERATE
ON A LEVEL SURFACE



**High altitudes/
Extreme temperatures**

REFER TO THE OWNER'S MANUAL FOR SPECIFIC RECOMMENDATIONS



Battery safety

REFER TO THE OWNER'S MANUAL FOR
MAINTENANCE AND SAFETY RECOMMENDATIONS

PH2100PRI

Inverter
Generator

What you need to Get started



Oil (15.6 oz of 15W-40)
Use 0W-40 in very cold weather



Gasoline (1.3 gal.)



Funnel



Phillips screwdriver



Battery charger

Box Contents

1. PH2100PRi generator
2. Oil jug
3. 2 keys
4. 2 remotes
5. Oil drain pipe
6. Spare fuse
7. Spark plug wrench
8. Screwdriver
9. Spare spark plug
10. Internal charging cable
11. Battery charge kit
12. Owner's manual



Please take a few moments to register your unit at www.powerhouse-products.com/register.

If you have a problem with this generator, do not return it to the store where you purchased it. For warranty support call 877-544-4449, 8am to 6pm ET, or email us at warranty@powerhouse-products.com.

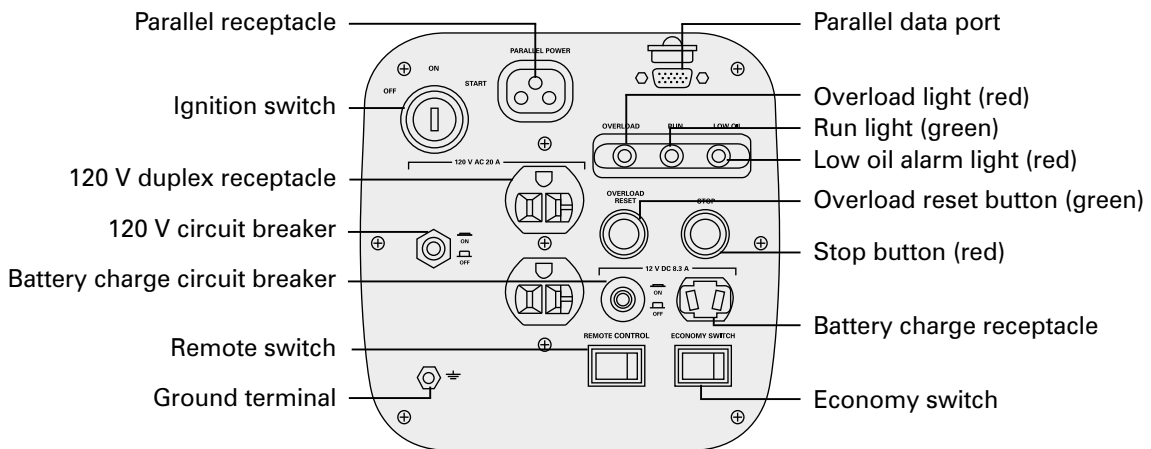
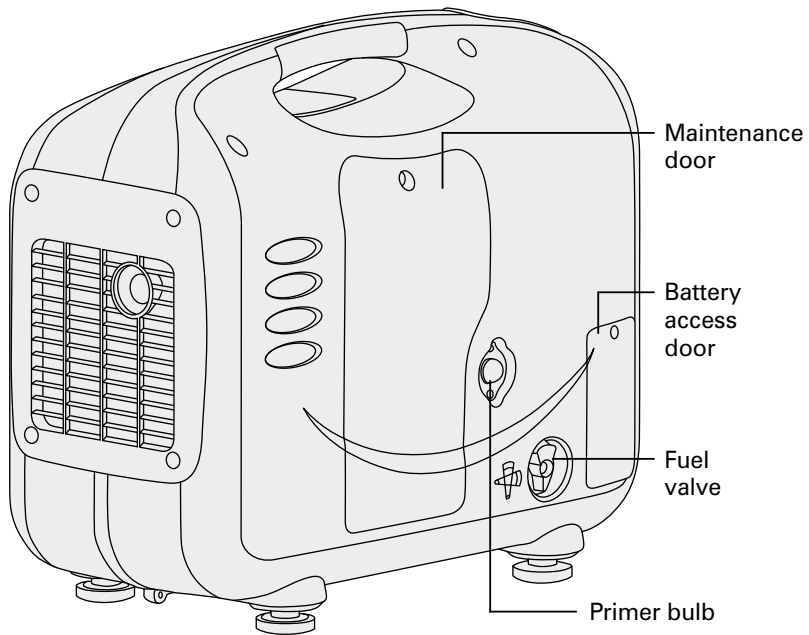
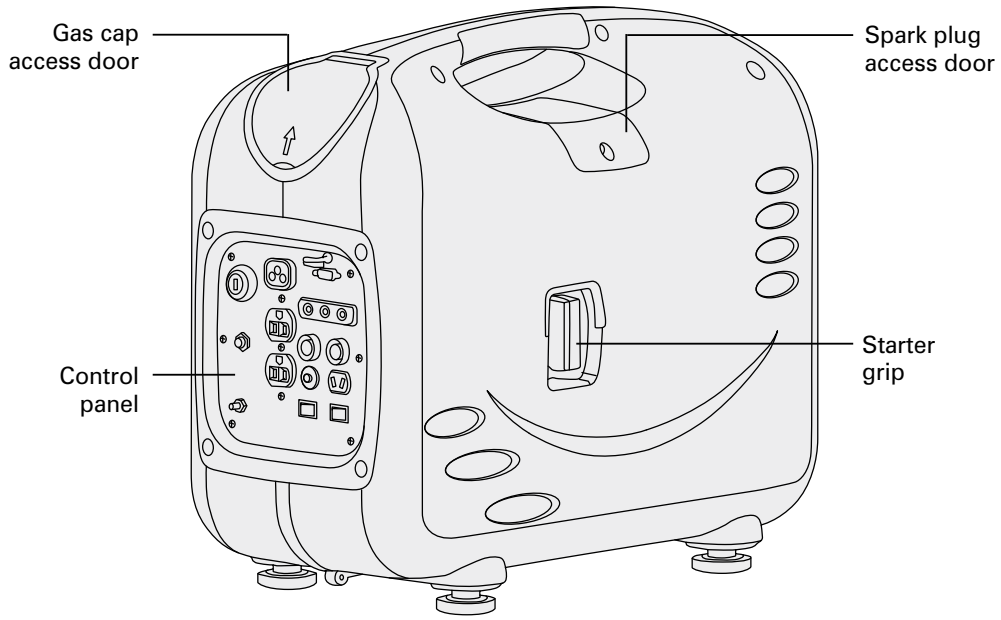

Initial setup

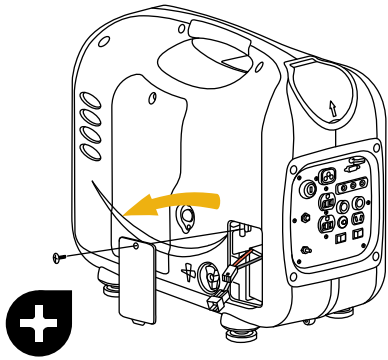

Open **battery access door**

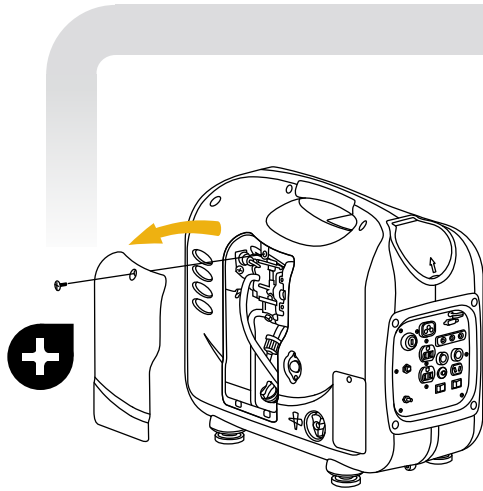

Remove **maintenance door**

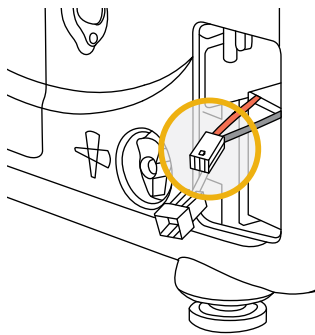

Locate **battery wiring harness**

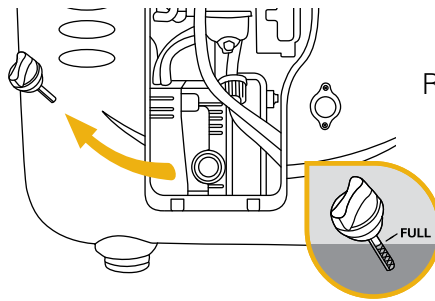

Remove **dipstick**

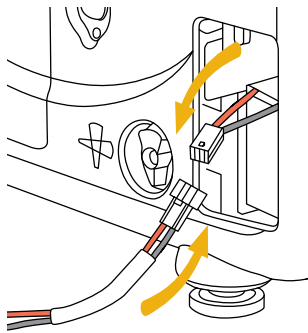

Connect **internal charging cable** to **battery wiring harness**

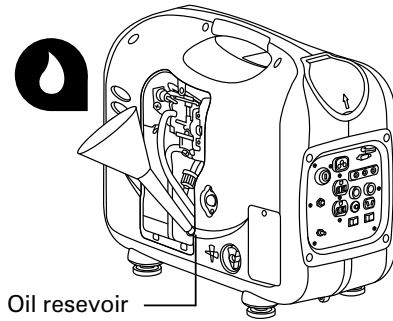

Add **oil** 

Add 15.6 oz. (460 ml) of oil or fill to full mark on dipstick

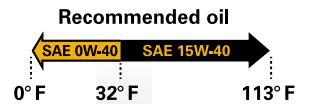

Oil reservoir

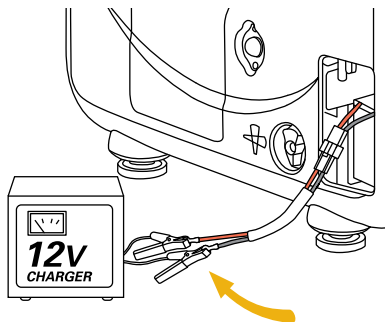

Connect **battery charger** to **internal charging cable**

Charge the battery for 3 hours or until fully charged

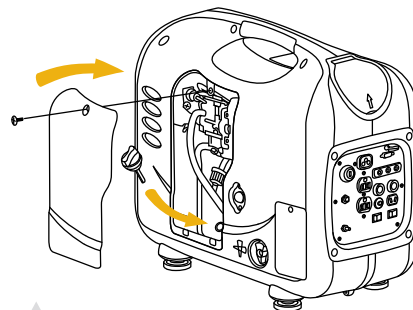

Replace **dipstick**

Replace **maintenance door**

(continued)

Initial setup (continued)

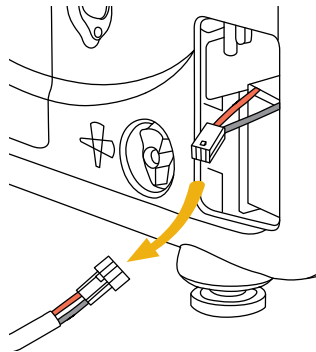

Disconnect **battery charger** and **charging cable**

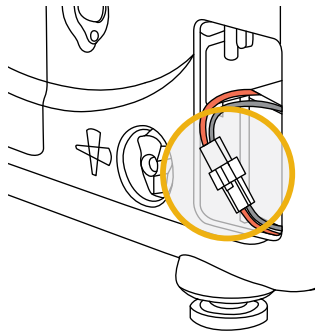

Connect **battery wiring harness** to **main wiring harness**

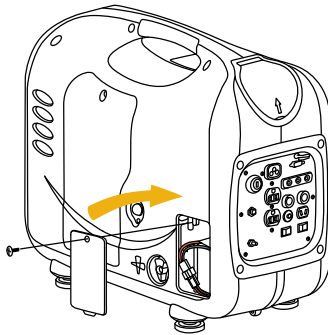

Replace **battery access door**

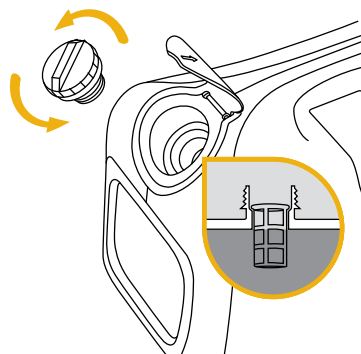

Add **gasoline**



Use gasoline with an octane rating of 87 or higher



Operation

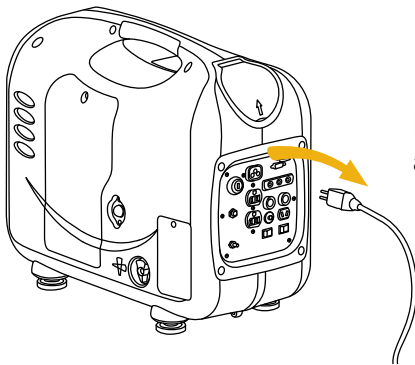

Disconnect appliances

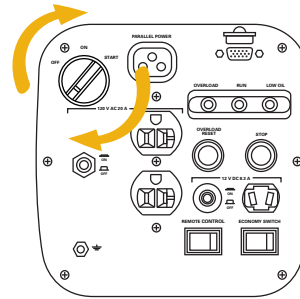
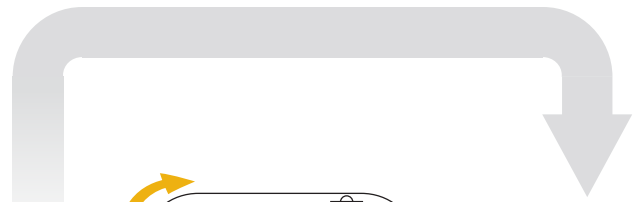

Turn **key** to start

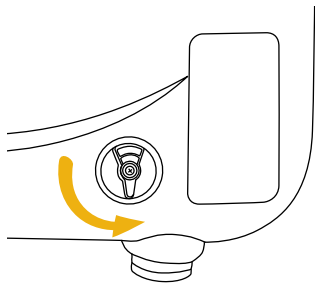

Open **fuel valve**

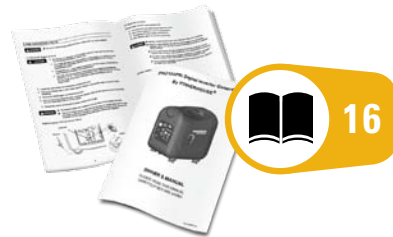

For additional starting options refer to pages 16-18 of the owner's manual

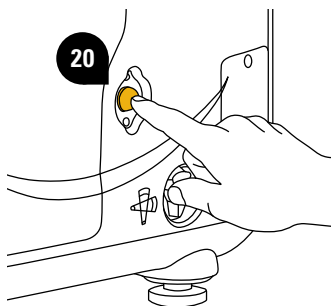

Pump **primer bulb** 15 to 20 times (initial startup only)

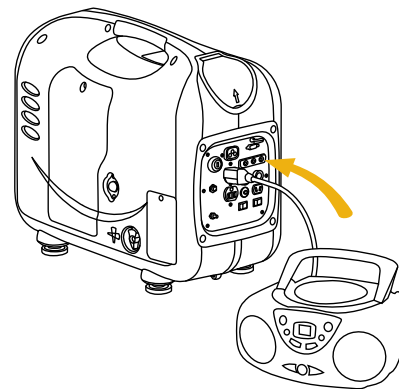

Connect appliances

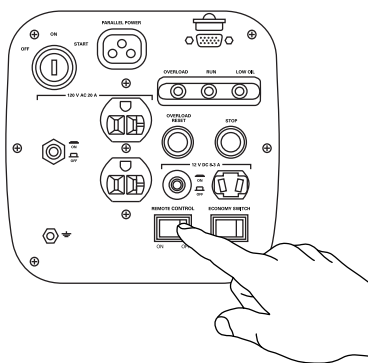

Turn **remote switch** off

For remote system instructions, refer to page 18 of the owner's manual

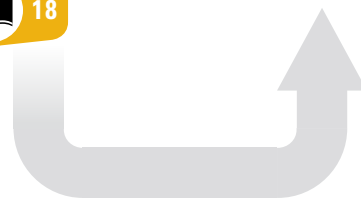

Shutdown

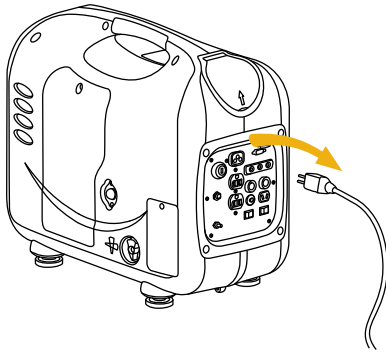

Disconnect appliances

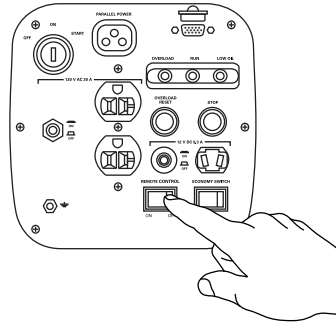

Turn **remote switch** off

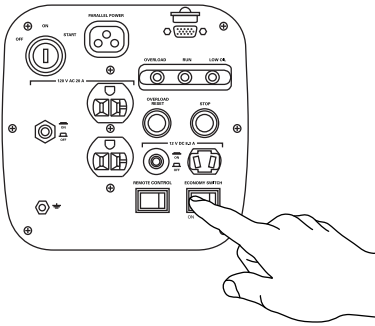

Turn **economy switch** on

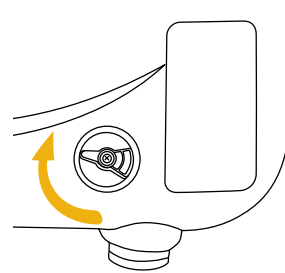

Close **fuel valve**

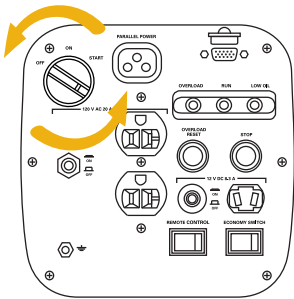

Turn **key** off

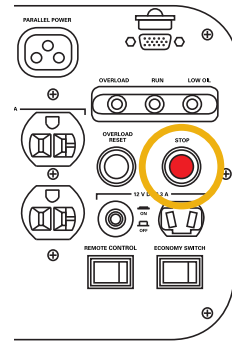

In emergency push and hold the STOP button until the engine is off