



115 VOLT GEAR OIL PUMP

1in. INLET

OWNER'S MANUAL



WARNING: Read carefully and understand all INSTRUCTIONS before operating. Failure to follow the safety rules and other basic safety precautions may result in serious personal injury.

Item # 22649

Thank you very much for choosing a Roughneck™ Product! For future reference, please complete the owner's record below:

Model: _____ Purchase Date: _____

Save the receipt, warranty and these instructions. It is important that you read the entire manual to become familiar with this product before you begin using it.

This machine is designed for certain applications only. The distributor cannot be responsible for issues arising from modification. We strongly recommend this machine is not modified and/or used for any application other than that for which it was designed. If you have any questions relative to a particular application, DO NOT use the machine until you have first contacted distributor to determine if it can or should be performed on the product.

For technical questions, please call **1-800-222-5381**.

⚠ WARNING: Read carefully and understand all INSTRUCTIONS before operating. Failure to follow the safety rules and other basic safety precautions may result in serious personal injury. Save these instructions in a safe place and on hand so that they can be read when required. Keep these instructions to assist in future servicing.

INTRODUCTION

Pump: Electric self-priming rotary internal gear pump, equipped with a bypass valve.

Motor: Asynchronous motor, 4-pole, closed type (Protection class IP55), self-ventilating, flange-mounted directly to the pump body.

The pump is designed to run on 115V, 60HZ power and supply a flow rate of up to 52 quarts/min. (13 GPM) with high-viscosity oils and lubricants.

TECHNICAL SPECIFICATIONS

Model	22649
Voltage	115 Volts
Frequency	60Hz
Power	1500 Watts
Flow Rate	52 quarts/min. (13 GPM)
Pressure	145 PSI
Inlet/Outlet	1in.

NOTE: The power absorbed by the pump depends on the functioning point and the viscosity of the oil being pumped.

Installation Dimension

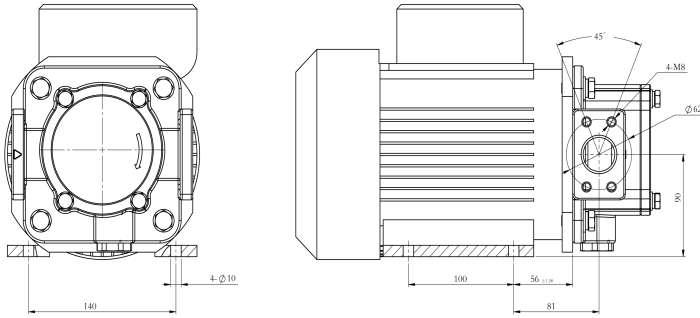

GENERAL SAFETY REGULATIONS

⚠ WARNING: Read and understand all instructions.

⚠ WARNING: The warnings, cautions, and instructions discussed in this instruction manual cannot cover all possible conditions or situations that could occur. It must be understood by the operator that common sense and caution are factors that cannot be built into this product, but must be supplied by the operator.

- 1. Keep the work area clean and dry.** Damp or wet work areas can result in injury.
- 2. Keep children away from work area.** Do not allow children to handle this product.
- 3. Store idle equipment.** When not in use, tools and equipment should be stored in a dry location to inhibit rust.
- 4. Use the right tool for the job.** Do not attempt to force small equipment to do the work of larger industrial equipment. There are certain applications for which this equipment was designed. It will do the job better and more safely at the capacity for which it was intended. Do not modify this equipment, and do not use this equipment for a purpose for which it was not intended.
- 5. Check for damaged parts.** Before using this product, carefully check that it will operate properly and perform its intended function. Check for damaged parts and any other conditions that may affect the operation of this product. Replace damaged or worn parts immediately.
- 6. Do not overreach.** Keep proper footing and balance at all times to prevent tripping, falling, back injury, etc.
- 7. DO NOT use the equipment when tired or under the influence of drugs, alcohol, or medication.** A moment of inattention while operating this equipment may result in serious personal injury.
- 8. Industrial applications must follow OSHA requirements.**

SPECIFIC OPERATION WARNINGS

	⚠ DANGER
	<p>Electrical shock hazard. Electrical wiring should be done by a licensed electrician in compliance with local, state and national electrical code, ANSI/NFPA 70, 30, 30A as appropriate. Proper ground must be provided to avoid the possibility of electrical shock. Failure to comply with this warning could result in serious injury and/or loss of property.</p>

⚠ WARNING: Improper use or installation of this product can cause serious bodily injury or death.

NOT FOR USE WITH LIQUIDS AS GASOLINE, ALCOHOL, EXPLOSIVES, CORROSIVES AND FLAMMABLE, ALIMENTARY LIQUIDS.

- Do not use the unit in an explosive environment.
- Do not use the unit next to flammable liquids (gasoline, alcohol, etc.).
- Do not use the unit in closed environments in presence of gasoline, LPG, methane fuelled vehicles.
- Always wear suitable clothes and use suitable protective devices when cleaning, especially when removing dust or waste. Use aspirators as needed.
- Never place hands or limbs under moving parts.
- Disconnect power to pump before servicing.

OPERATING CONDITIONS

1. OPERATING ENVIRONMENTAL CONDITIONS

Temperature: Min 14°F (-10°C) / Max +140°F (+60°C)

Relative Humidity: Max 90%

⚠ WARNING:

The temperature limits should be applied to the pump components and must be respected to avoid possible damage or malfunction.

Nevertheless, it should be understood that for a given oil, the real functioning temperature range also depends on the variability of the viscosity of the oil itself with different temperatures. Specifically:

- At temperatures below 14°F, the viscosity of some oils can greatly exceed the maximum allowed by this pump, which will cause that the static torque required to start the pump would be excessive, and the pump may overload and suffer damage.
- At temperatures above +140°F, on the other hand, the viscosity of some oils can drop well below the minimum allowed by this pump, causing back pressure increases, which can lead to degradation of pump performance, with obvious reductions in flow rate.

2. ELECTRICAL POWER SUPPLY

The AC pump must be supplied by a single-phase alternating current line whose nominal values are shown in the table TECHNICAL SPECIFICATIONS above. The maximum acceptable variations from the electrical parameters are:

Voltage: $\pm 5\%$ of the nominal value (115 Volts).

Frequency: $\pm 2\%$ of the nominal value (60Hz)

 **WARNING:**

Power supplied from lines with values outside the indicated limits can damage the electrical components.

3. WORKING CYCLE

Under normal operating conditions they can function continuously with no limitations.

 **WARNING:** DO NOT KEEP THE PUMP WORK IN BYPASS CONDITION MORE THAN 2 MINUTES. Whenever a particular installation carries the risk of functioning in bypass mode for longer periods of time, it is necessary to return the bypassed flow to the suction tank; do not recirculate inside the pump.

4. FLUID ALLOWED / FLUIDS NOT ALLOWED

ALLOWED: Oil with a Viscosity from 500 to 2000 Cst (at working temperature)

NOT ALLOWED	RELATED DANGER
Gasoline (Petrol)	Fire - explosion
Inflammable liquids with PM < 55°C	Fire - explosion
Water	Oxidation of the pump
Liquid food products	Contamination
Corrosive Chemicals	Corrosion of the pump Injury to people
Solvents	Fire – explosion Damage to gasket seals

 **WARNING:** The gear pump is sensitive to polluted fluids; DO NOT deliver fluids with impurities.

INSTALLATION

1. PRELIMINARY INSPECTION

- Check that the pump has not suffered any damage during transport.
- Clean the inlet and outlet openings with care, removing any dust or packing residue.
- Make sure that the motor shaft turns freely.
- Check that the electrical information corresponds with what is shown on the label.

2. MECHANICAL INSTALLATION

The gear pumps can be installed in the following ways:

a. On an horizontal base

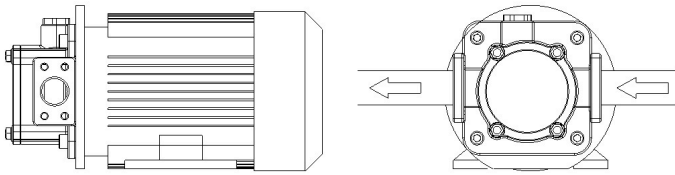

b. With the pump body upwards

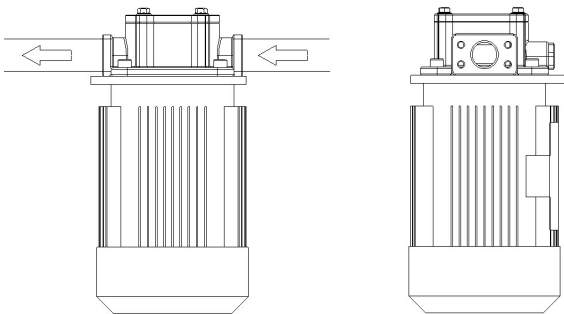

c. With pump body aside

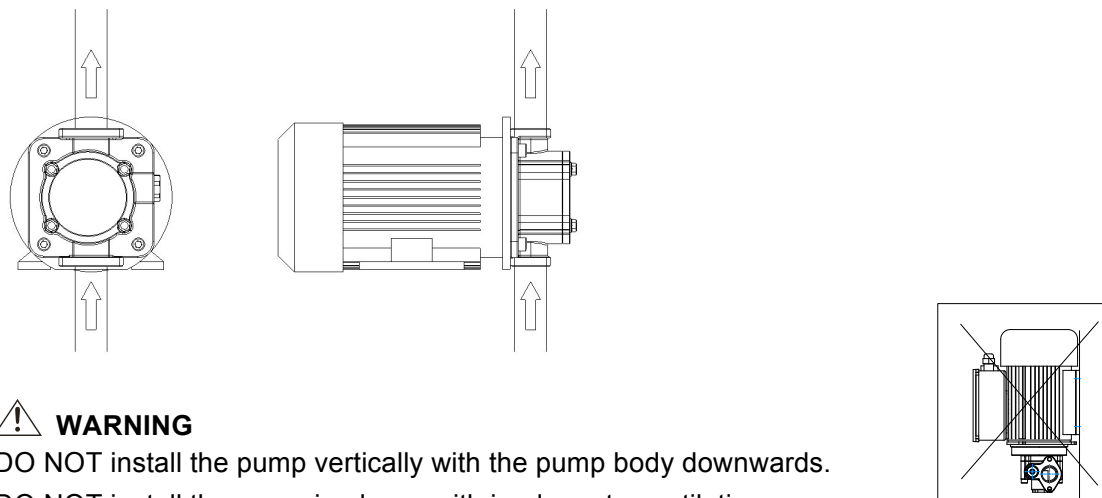

! WARNING

DO NOT install the pump vertically with the pump body downwards.

DO NOT install the pump in places with inadequate ventilation.

If absolutely necessary, install a foot valve and fill the suction tube with oil during the first priming phase.

Fix the pump using screws of a diameter suitable for the provided holes.

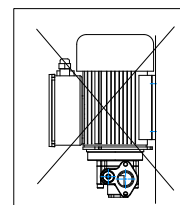

3. HYDRAULIC CONNECTION

- Before connection, make sure that the hoses and the suction tank are free of dirt and thread residue that could damage the pump and its accessories.
- Always install a metal mesh filter in the suction hose.
- Before connecting the delivery hose, partially fill the pump body with oil to avoid the pump running dry during the priming phase.

Suction Hose

- Minimum nominal recommended diameter: 1in.

-
- Use a hose suitable for functioning under suction pressure.

Delivery Hose

- Minimum nominal recommended diameter: 1in.

WARNING:

1. Hoses and/or line components unsuitable for use with oil or with inadequate nominal pressures can cause damage to objects or people, as well as pollution.
2. Use oil-resistant pipe sealant or Teflon® Tape on all pipe threads.
3. Check all the connections before each use. Tighten them if necessary. Loosening of the connections (threaded connections, flanging, gasket seals) can cause serious ecological and safety problems.

4. SUCTION AND DELIVERY LINES

DELIVERY

The proper pump should be chosen considering the viscosity of the oil to be pumped and the characteristics of the system attached to the delivery of the pump. The improper application of the oil viscosity and the characteristics of the system could create unexpected large back pressure, which may cause the (partial) opening of the pump bypass and consequently reduce the flow rate.

It is recommended to use shorter tubing and/or tubing with larger diameter to reduce system resistance, so that the pump would function equally to the viscosity of the oil being pumped.

SUCTION

The gear-type oil pumps are characterized by excellent suction capacity. In fact, the characteristic flow rate/back pressure curve remains unchanged even at high pump suction pressure values.

The pump will prime to a height of 6.5 feet (2 meters) when the suction hose is empty and the pump is filled with the fluid. On tanks with a suction height over 6.5 feet, a foot valve may be required on the bottom of the suction tube to hold the fluid in the tube. Do not install the pump with a height higher than 9.8 feet (3 meters), or the pump will lose its prime.

 **WARNING:** In the case that the suction tank is installed higher than the pump installation, it is recommended to install an anti-siphon valve to prevent accidental diesel fuel leaks. Care should be taken during the installation process in order to control back pressure.

INITIAL STARTUP

The gear-type oil pumps are self-priming and therefore, able to draw oil from the tank even when the suction hose is empty during startup.

WARNING:

Always wet the inside of the pump body with oil through the inlet and outlet openings before starting the pump. If the pump is installed before being wetted, unscrew the threaded plug of the inlet opening which are not in use, fill the internal chamber with oil and then screw in the plug. During the operations, pay attention to the O-ring seal.

If no foot valve is applied, it is advisable to leave the purge valve open at all times to make sure the air present in the suction hose is purged once the device is restarted again. During the operation, make sure there is always a small part of oil recirculating in the tank.

If a foot valve is applied, close the air purge valve by turning it clockwise to make sure no oil circulates in the tank. Make sure the foot valve seal performs well.

The priming phase may last from several seconds to a few minutes, depending on the characteristics of the system.

If this phase is excessively prolonged, stop the pump and verify:

- That the pump is not running completely “dry.”
- That the suction hose is preventing air infiltration and is correctly immersed in the fluid to be drawn.
- That any filters installed are not blocked.
- That the priming height is not greater than 6.5 feet (2 meters).
- That the delivery hose allows for the easy evacuation of air.
- When priming has occurred, after reattaching the delivery gun, verify that the pump is functioning within the anticipated ranges, possibly checking:
 - 1) that under conditions of maximum flow the energy drawn by the motor falls below the values indicated on the label.
 - 2) that the back pressure in the delivery line does not exceed the values.

DAILY USE

- 1) Before starting the pump, make sure that the ultimate shut-off device (delivery gun or line valve) is closed.
- 2) Turn the on-switch.
- 3) Make sure that the tank is filled with a quantity of oil greater than the quantity to be supplied (running dry could damage the pump)

 **WARNING:** Never start the pump by simply inserting the plug in the outlet.

4) Open the delivery valve or activate the delivery gun, gripping it securely.

5) Close the delivery gun or the line valve to stop delivery. The pump will immediately enter by-pass mode.

 **WARNING:** Running in by-pass mode with the delivery closed is only allowed for brief periods (2 minutes maximum).

6) Stop the pump.

MAINTENANCE

The pumps are designed and constructed to require a minimum of maintenance.

- On a weekly basis, check that the tubing joints have not loosened, to avoid any leakage.
- On a monthly basis, check the pump body and keep it clean of any impurities.
- On a monthly basis, check and keep the pump filter clean and any other filters installed.
- On a monthly basis, check that the electric power supply cables are in good condition.
- Under normal working conditions the noise emission from all models does not exceed the value of 70 db at a distance of 1 meter from the electric pump.

TROUBLE SHOOTING

PROBLEM	POSSIBLE CAUSE	CORRECTIVE ACTION
Motor does not turn	Lack of power	Check electrical connections and safety systems
	Rotor jams	Check for possible damage or obstruction to rotating parts
	Thermal motor protector has triggered	Wait until the motor cools, verify that it starts again, look for the cause of overheating
	Problems with the motor	Contact technical support
Motor turns slowly when starting	Low voltage from the electrical power supply	Adjust the voltage within anticipated limits
	Excessive oil viscosity	Verify oil temperature and warm it to reduce excessive viscosity
Little or no flow	Low level in the suction tank	Fill in the tank
	Foot valve blocked	Clean and/or replace valve
	Filter blocked	Clean the filter
	Excessive suction pressure	Lower the pump with respect to the level of the tank or increase the cross-section of the hose
	High load loss in the delivery circuit (running with by-pass open)	Use shorter hose or of wider diameter
	By-pass valve blocked	Detach the valve, clean or replace it
	Air in the pump or suction hose	Check the seal of the connection
	Narrowing of the suction hose	Use a hose appropriate for working under suction pressure
	Low rotation speed	Check the voltage at the pump. Adjust the voltage or use cables of greater cross-section
	Excessive oil viscosity	Verify the oil temperature and warm it to reduce the excessive viscosity
Higher pump noise	Cavitation	Reduce the suction pressure
	Irregular by-pass functioning	Deliver until the air in the by-pass system is purged
	Presence of the air in the oil	Wait for the oil in the tank to settle
Leakage from the pump body	Damage to the mechanical seal	Check and replace the mechanical seal

DIAGRAMS AND PARTS LIST

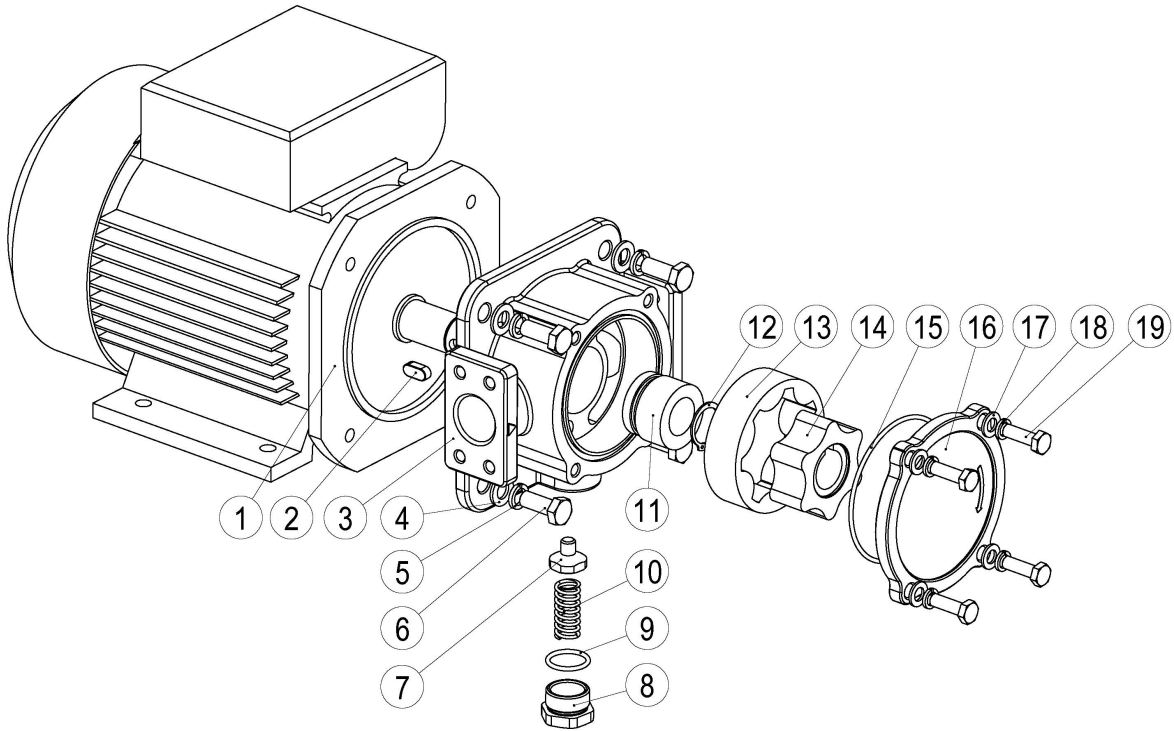

No.	Description	Quantity
1	Motor	1
2	Key	1
3	Machined pump head	1
4	Flat Washer	4
5	Spring washer	4
6	Hex Bolt	4
7	By-pass valve	1
8	By-pass plug	1
9	O-Ring 22.4X2.65	1
10	Spring	1
11	Machine Seal	1
12	Circlip	1
13	external rotor	1
14	internal rotor	1
15	O-ring	1
16	Pump Cover	1
17	Flat Washer	4
18	Spring Washer	4
19	Hex Bolt M8x15	4

For replacement parts and technical questions, please call **1-800-222-5381**.

WARRANTY

One-Year Limited Warranty



Distributed by
Northern Tool + Equipment Co., Inc.
Burnsville, MN 55306
NorthernTool.com
Made in China