

This manual contains important warnings and information. READ AND KEEP FOR REFERENCE.

# LIQUIDYNAMICS DEF Bulk Transfer Systems

## Instruction & Parts Manual

This Manual Covers all  
DEF Bulk Transfer Systems

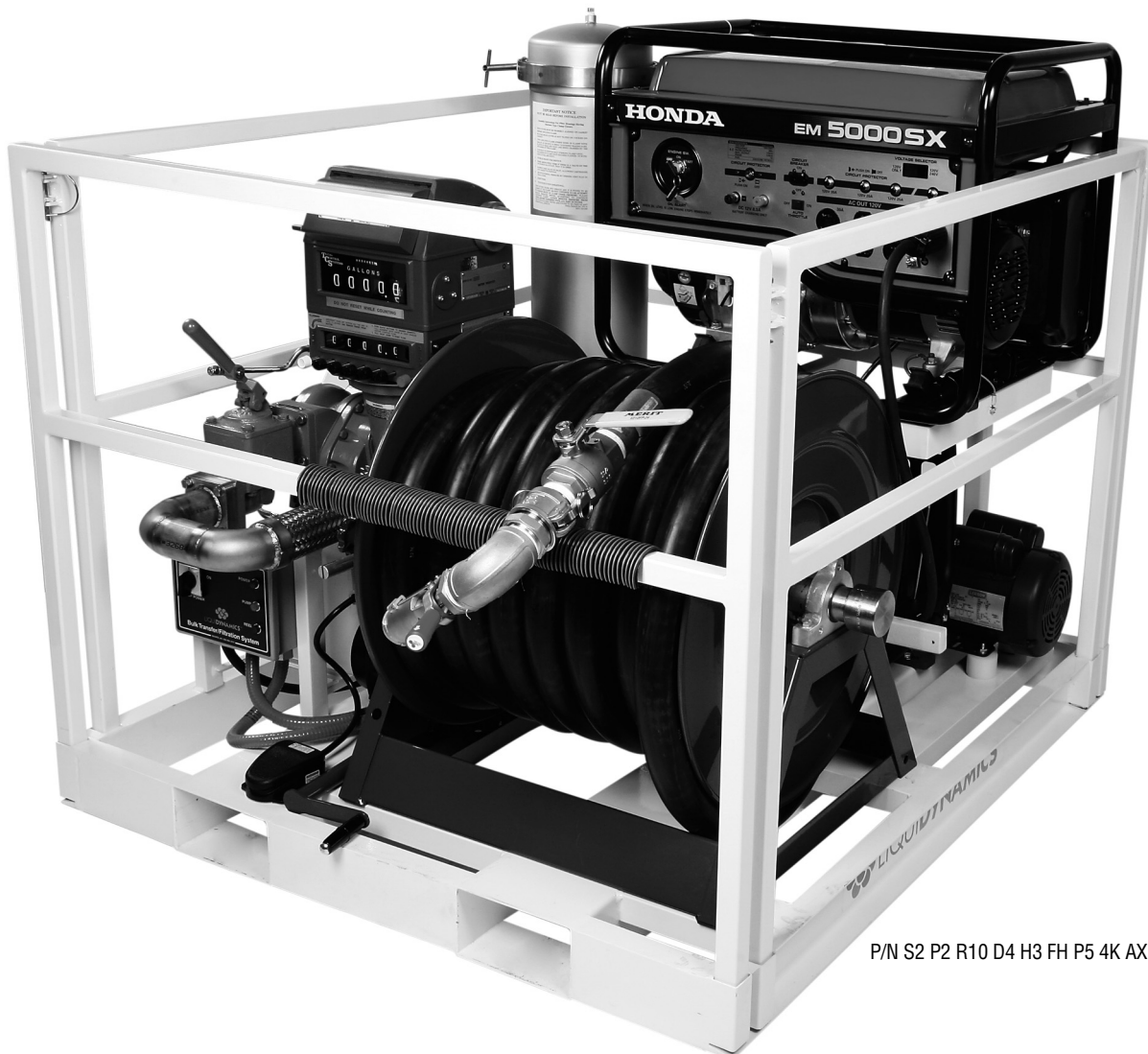

P/N S2 P2 R10 D4 H3 FH P5 4K AX shown

# **WARNING**

This symbol indicates a potentially hazardous situation which, if not avoided, could result in death or serious injury.

## **READ THIS MANUAL CAREFULLY BEFORE OPERATING OR SERVICING THIS EQUIPMENT.**

It is the responsibility of the employer to place this information in the hands of the operator. Keep for future reference.

# **WARNING**

DO NOT USE THIS CART SYSTEM TO PUMP FLAMMABLE, EXPLOSIVE OR CORROSIVE PRODUCTS SUCH AS GASOLINE, DIESEL FUEL, METHANOL, OR CHEMICALS.

# **WARNING**

Before each use, inspect the power cord to ensure it is not cut, nicked, has any exposed wires and ground lug on plug is intact and functional.

## **UNCRATING & ASSEMBLY:**

1. When removing carton exercise caution not to cut hose or power cord that may have shifted during transport.
2. Remove straps securing pump assembly from shipping pallet.
3. Inspect for damage. If damage is found please report damage to freight carrier.

Part Number # \_\_\_\_\_

Voltage: \_\_\_\_\_

Motor Serial # \_\_\_\_\_

Tested by: \_\_\_\_\_

Gearbox Serial # \_\_\_\_\_

Date: \_\_\_\_\_

Pump Serial # \_\_\_\_\_

# **CAUTION**

This symbol indicates a potentially hazardous situation which, if not avoided, may result in injury or damage to equipment.

All pumps have been assembled and tested at the factory and are ready for use. In cases where hoses are not provided, a few general guidelines should be followed.

## **Suction Hose:**

- Use non-collapsible hose rated for 25" Hg Vacuum.
- Should be the same size as pump inlet or larger
- Short as practical, no greater than 20' in length.

## **Discharge Hose:**

- Should be the same size as pump discharge or larger.
- Short as practical.

## **INTRODUCTION**

The Liquidynamics Diesel Exhaust Fluid bulk transfer skid is constructed for the sole purpose to bulk transfer DEF in accordance to high purity industry standards and conforms to ISO 22241-3.

# **WARNING**

Under no circumstances shall this DEF bulk transfer skid be used to handle anything other than Diesel Exhaust Fluid!

If operating temperatures are less than 17 degrees F, it is recommended to drain the entire system to prevent serious damage to the pump, meter, reel and other components. This procedure will require removal of multiple drain plugs located at the pump, filter and meter. Additionally, fluid must be drained from the dispensing hose and reel by removing the sanitary clamp next to the hose swivel. Drain the hose by uncoupling the discharge valve on end of hose and unwind the hose from the reel thus allowing the fluid to drain from the sanitary connection and discharge valve.

**NOTE:** Sealant used for threaded connections

As of the printing of this manual, none of the DEF manufacturers have approved ANY thread sealant compound (including Teflon based sealant paste) other than Teflon tape to be used.

In keeping with constructing systems that meet DEF industry purity standards, Liquidynamics uses Teflon tape for threaded connections.

When using only Teflon tape to seal threaded connections, it is not uncommon over time that connections can experience slight “caking” due to out gassing, this is harmless and can be rinsed with water to remove the “caking”.

## TECHNICAL DATA

Reference manufacture data sheet.



Before each use, inspect the power cord to ensure it is not cut, nicked, has any exposed wires and ground lug on plug is intact and functional.

## TRANSFER OPERATION

1. Ensure power switch located on control panel is in the off position.
2. Insert power cord plug into 115V receptacle, (If system is a 70 GPM transfer system plug into a 220V outlet) Confirm Green power light is illuminated indicating control panel has power.

**NOTE:** If system is equipped with on board generator ensure power cord is securely plugged into the proper outlet before starting the generator.

3. Connect male dry-break from one end of the suction hose to the female dry break connecter located at the pump.
4. Connect opposite end of the suction hose “female dry-break” to the mating male dry-break supplied with the system. This valve can be threaded on to a 2” male NPT.
5. If running for the first time or pump has been drained to prevent freezing pump will need to be primed by removing the priming plug on top of the pump and filling chamber with DEF or if system is connected to a flooded suction loosen priming plug allowing air to escape until fluid begins to flow from the priming plug.
6. Turn on the Pump Power switch the indicator light will illuminate and pump motor will energize. Once the ball valve and/or MicroMatic is opened observe meter to confirm flow.

**NOTE:** Occasionally while product is moving through the filter observe filter differential pressure gauge to check condition of the filter elements.

7. After filling operation is complete close all valves and shut off pump.
8. It is considered a good practice to carry the MicroMatic valve and hose end back to the skid so as not to drag the hose end assembly on the ground.
9. While guiding the discharge hose as it enters the reel; depress the reel rewind switch with foot to energize reel rewind.

10. Stow the suction hose. Note: The suction hose has dry break valve assemblies on each end which must be closed before they will be allowed to uncouple. This helps maintain system cleanliness.

**NOTE:** When dispensing through the MicroMatic Fill Valve , flow is reduced to 30 GPM due to MicroMatic valve restrictions.

**NOTE:** Flow rates will vary due to geographic elevations, head pressure and filter cleanliness.

## MAINTENANCE

### Frequency

Since usage varies for different users, the frequency and extent of pump maintenance is best established based upon past performance. Keeping detailed maintenance records of past performance aids in determining future preventive maintenance intervals. During routine operating inspections, pay particular attention to seal, bearing areas of the pump and abnormal vibration or noise.



Before attempting to service the pump disconnect motor power and release all pressure within the system. Wear appropriate personal protection equipment and handle equipment with care.

### Inspect for Wear

#### PUMP

If the pump exhibits reduced flow, an inability to maintain pressure, is noisy or performs otherwise abnormally; refer to the Troubleshooting Matrix.

If the problem persists, the pump should be inspected for wear or damage. Full pump removal and complete disassembly may be needed for a comprehensive inspection. Contact the factory.

#### MOTOR

2 HP 115/230V or 3 HP 230V TEFC Totally enclosed fan cooled motor.

No preventive maintenance is required on motor assembly.

Visually inspect to ensure shroud, mounting bolts and electrical cords are secure.

Sealed bearings require no lubrication.



Not approved for Class I Div 2 explosion proof environment

Figure 1.

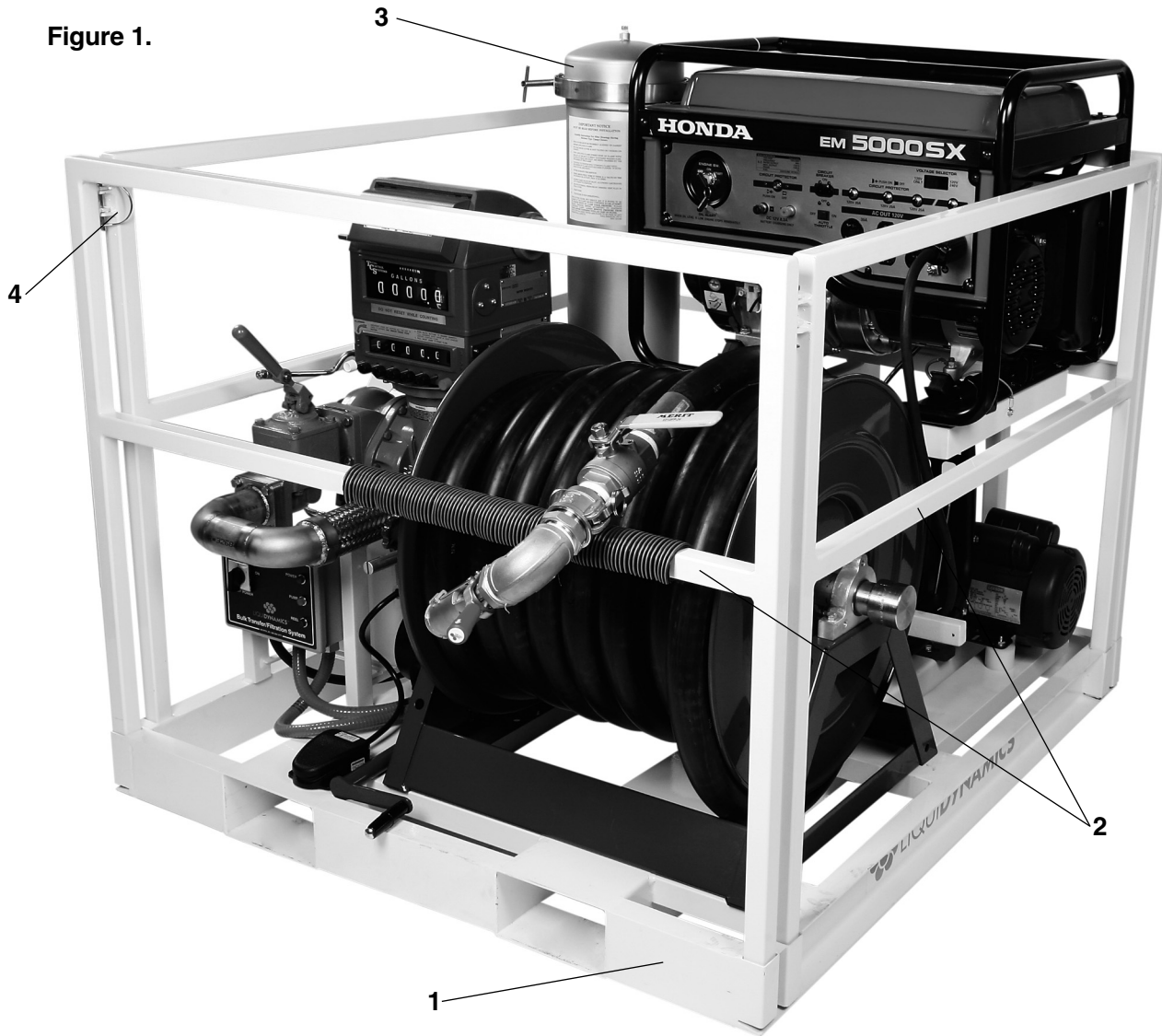

Figure 2.

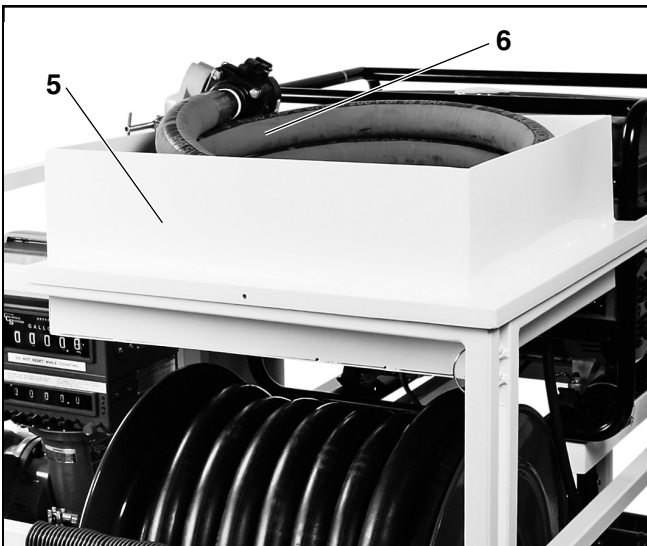

Figure 1 and Figure 2:

PART NO.	DESCRIPTION
1. 195300	Skid Frame, Powder Coated
2. 195301A	Guard Rail, Back and Front
195301B	Guard Rail, Left and Right
3. 195195A	Filter Housing
195194-01	Filter Elements, 1 Micron (5 req.)
900639	Band Clamp, 5 element filter
900640	Band Clamp, 7 element filter
4. 900128	Clevis Pin
5. 195303	Hose Tray
6. 81243-10	1½" x 10' Suction Hose
81243-15	1½" x 15' Suction Hose
81243-20	1½" x 20' Suction Hose
900580A	DryMate Coupler, 1½" NPTF
900581A	DryMate Coupler, 1½" NPTM

Figure 3.

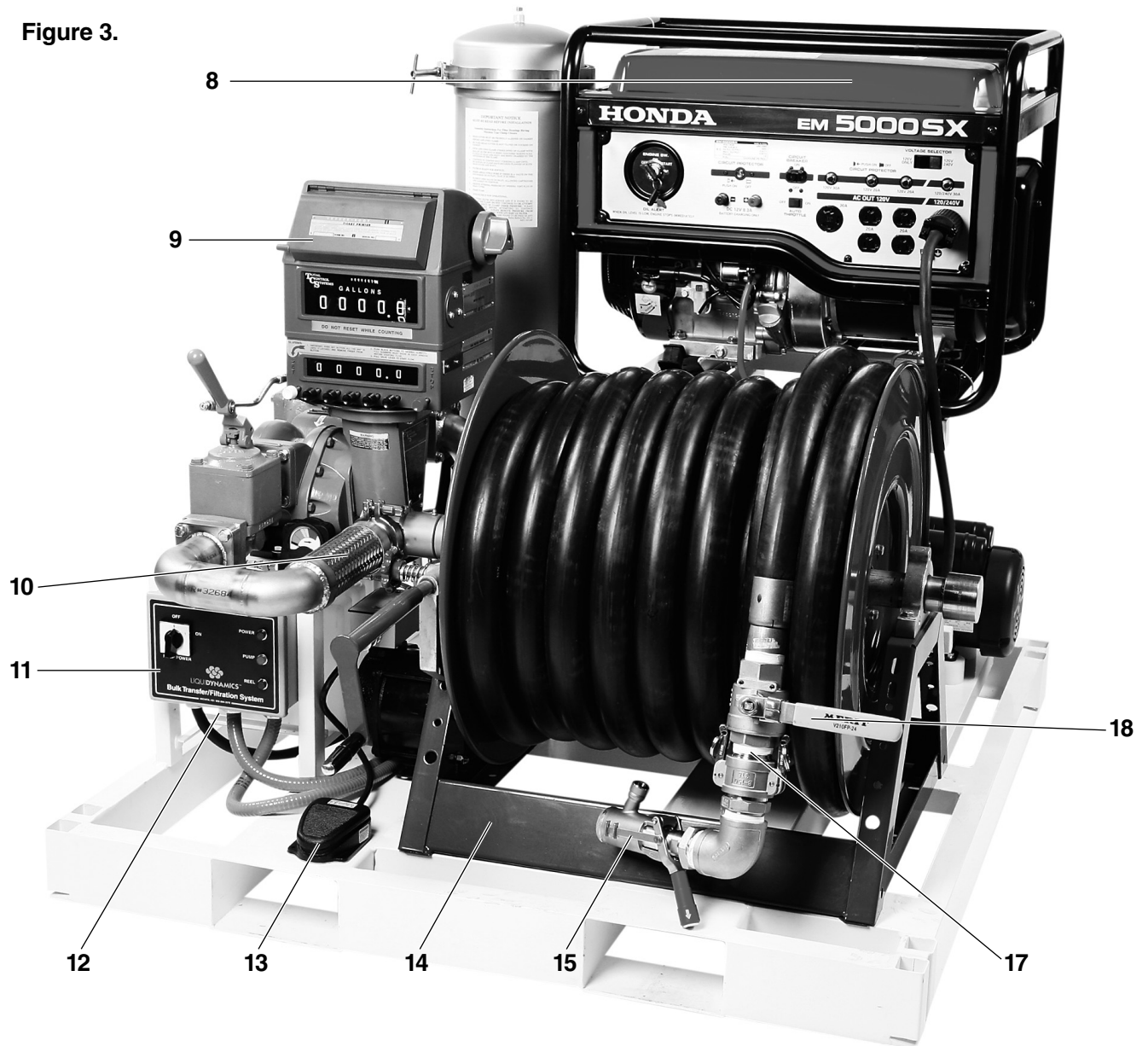
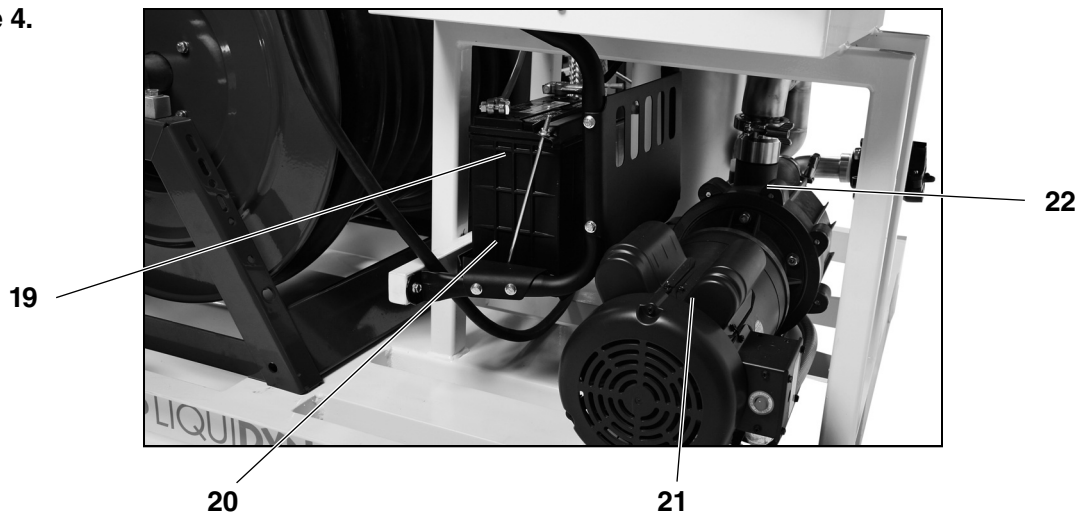

Figure 3:

PART NO.	DESCRIPTION
8. 195320	Honda Generator, EM 3000SX
195321	Honda Generator, EM 5000SX
9. 195260A	40 GPM SS Meter, 1½" w/mechanical register
195260B	40 GPM SS Meter, 1½" w/mech. register & printer
195261A	40 GPM SS Meter, 1½" w/preset & mech. register
195261B	40 GPM SS Meter, 1½" w/preset, mech. register & printer
195263B	75 GPM SS Meter, 1½" w/preset, mech. register & printer
10. 195179	2" SS Flex Hose, Meter to Reel
195176	2" Tri Clamp
195175	2" Teflon Gasket for Tri Clamp
11. 195290	Electrical Control Box w/Cables
905073	Power Switch, Rotary

PART NO.	DESCRIPTION
12. 195330	Differential Pressure Gauge
13. 905052	Foot Pedal, 115 VAC Reel
195162	Foot Pedal, Air Operated
14. 195164A	115 VAC DEF Hose Reel w/ hand crank capability
195163	12 VDC DEF Hose Reel w/ hand crank capability
195161A	Air Operated DEF Hose Reel w/hand crank capability
81242-50	1½" x 50' DEF Hose, 1½" NPTM
81242-75	1½" x 75' DEF Hose, 1½" NPTM
81242-100	1½" x 100' DEF Hose, 1½" NPTM
15. 195205F	MicroMatic RSV Fill Valve, 1" NPTM inlet fitting
17. 900600	1½" SS Camlock, Male adapter
900601	1½" SS Camlock, Female coupler
18. 900620	1½" Ball Valve shutoff

**Figure 4.**



**Figure 5.**

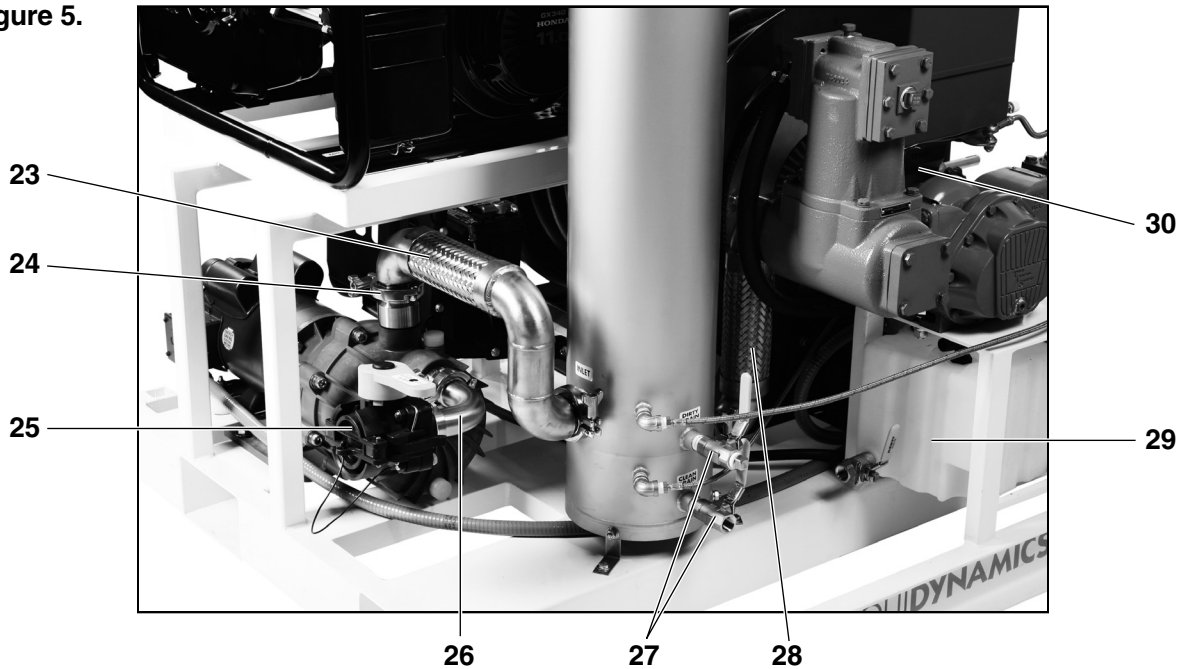

**Figure 4:**

PART NO.	DESCRIPTION
19. 905078	12 VDC Battery
20. 195305-02	Battery mounting bracket
21. 905040	2 HP Motor, 115 VAC
905041	3 HP Motor, 115 VAC
22. 195253A	Magnetic drive centrifugal pump, 40 GPM
195253B	Magnetic drive centrifugal pump, 70 GPM
195251	Magnetic drive centrifugal pump, 40 GPM, for gas engine drive

**Figure 5:**

PART NO.	DESCRIPTION
23. 195177	2" SS Flex Hose, Pump to filter
195176	2" Tri-Clamp
195175	2" Teflon Gasket for Tri Clamp
24. 195173	2" SS Female BSP to Tri-Clamp adapter
195180	'O' Ring, EPDM
25. 900580	Poly DryMate, 2" NPTF
26. 900607	1½" SS suction elbow
27. 900611	1/2" SS drain valve
28. 195182	3/16" x 32" SS connection hose
29. 901090T-01	1½ gal. poly drip tank
30. 195178	2" SS Flex hose, filter to meter
195176	2" Tri-clamp
195175	2" Teflon gasket for Tri-clamp

## Troubleshooting Matrix

Difficulty	Probable Cause	Remedy
No Liquid Delivery	1. Closed Valves	Open valves
	2. Plugged suction	Eliminate restriction
	3. Air leak at suction	Locate and repair leak
	4. Filter plugged	Check filter Delta P (replace filter)
	5. Suction lift too high	Do not exceed vapor pressure of liquid
	6. Motor wired incorrectly	Check wiring diagram
	7. Wrong rotation	Correct rotation (from back of motor – clockwise)
Low Liquid Delivery	1. Discharge pressure too high	Reduce downstream pressure
	2. Filter plugged	Check filter Delta P (replace filter)
	3. Air leak at suction	Locate and repair leak
	4. Worn or damaged pump	Inspect and repair as required
Gradually Loses Prime	1. Suction lift too high	Improve suction pressure
	2. Air leak at suction	Locate and repair leak
	3. Worn or damaged pump	Inspect and repair as required
Noisy	1. Cavitating	Improve system suction pressure, provide adequate NPSH (net positive suction head)
	2. Solid particles in fluid	Clean suction strainer
	3. Air in fluid	Eliminate air from fluid
	4. Worn or damaged pump	Inspect and repair as required
Motor Runs Hot or Overloads	1. Discharge pressure too high	Reduce downstream pressure. Check relief valve setting. Be sure discharge pressure gauges function correctly
	2. Incorrectly wired motor	Check wiring diagram
	3. Binding internal pump parts	Inspect and correct condition
	4. Motors normally feel hot	Verify if actual motor amperage draw is correct



2211 S. Edwards • Wichita, KS 67213 / TEL: 316-943-5477 • FAX: 316-943-4760 / TOLL FREE: 800-894-3572  
E-MAIL: [productinfo@liquidynamics.com](mailto:productinfo@liquidynamics.com)