

Installation Instructions

.....

TGS07 Salt Spreader TGS07RED Salt Spreader TGS07YEL Salt Spreader

US PATENT 8,888,025; 9,562,333
other PATENTS PENDING

Serial Number 01700 and Higher

Spreader may not fit properly on some truck models. If hopper interferes with tailgate order TGS07 Extension Kit 3038520

Safety Precautions

WARNING

Observe the following Safety Precautions before, during and after operating this spreader. By following these precautions and common sense, possible injury to persons and potential damage to this machine may be avoided.

1. Read this entire Installation Instruction before operating this spreader.
2. Read all safety decals on the spreader before operating.
3. Verify that all personnel are clear of the spreader spray area before starting or operating this spreader.
4. Do not adjust, clean, lubricate or unclog material jams without first turning off the spreader.
5. Make sure the spreader is securely fastened to the vehicle in accordance with this manual.
6. Do not operate a spreader that is in need of maintenance or repairs.
7. Always disconnect the battery before removing or replacing electrical components.

Spreader Assembly

Check contents of box against parts list to make sure all components are included. When ordering replacement or spare parts refer to parts list for part numbers.



SPREADER WARRANTY

This warranty replaces all previous warranties and no employee of this company is authorized to extend additional warranties, or agreements, or implications not explicitly covered herein.

Buyers Products Company warrants all parts of the product to be free from defects in material and workmanship for a period of one (1) year. Parts must be properly installed and used under normal conditions. Normal wear is excluded.

Any part, which has been altered, including modifications, misuse, accident, or lack of maintenance will not be considered under this warranty.

The sole responsibility of Buyers Products Company under this warranty is limited to repairing or replacing any part(s), which are returned, prepaid, 30 days after such defect is discovered, and returned part(s) are found to be defective by Buyers Products Company.

Authorization from Buyers Products Company must be obtained before returning any part. The following information must accompany defective parts returned to Buyers Products Company: RMA #, spreader model, serial number, date installed, and distributor from whom purchased.

Buyers Products Company shall not be liable for damage arising out of failure of any unit to operate properly, or failure, or delay in work, or for any consequential damages. No charges for transportation or labor performed on any part will be allowed under this warranty.

1. Slide frame #3015859 into hitch receiver. Fig.1.

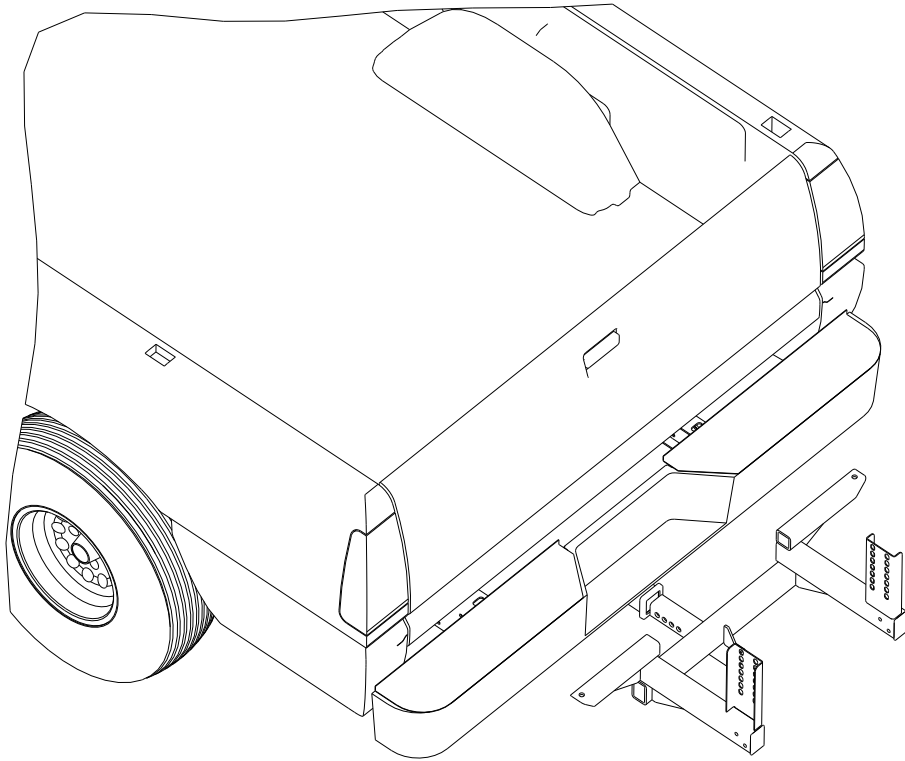

Fig. 1

2. Slide hopper assembly #3015380 between frame uprights with front portion rested on the truck's bumper. Fig.2.

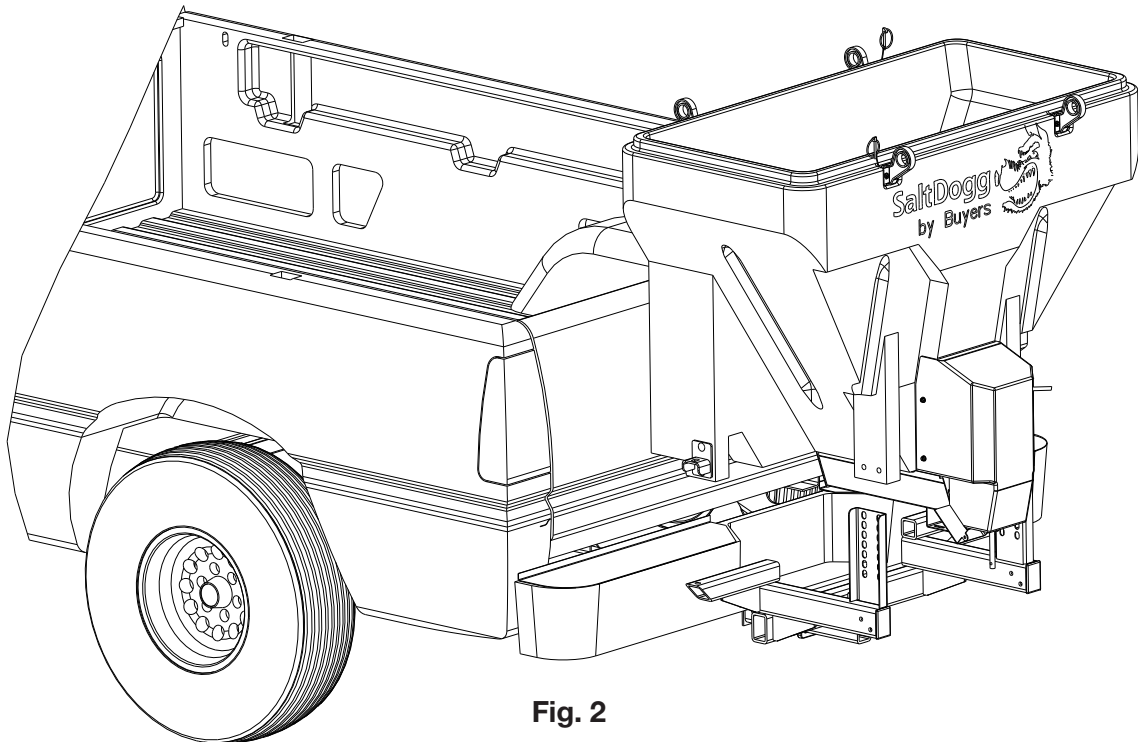
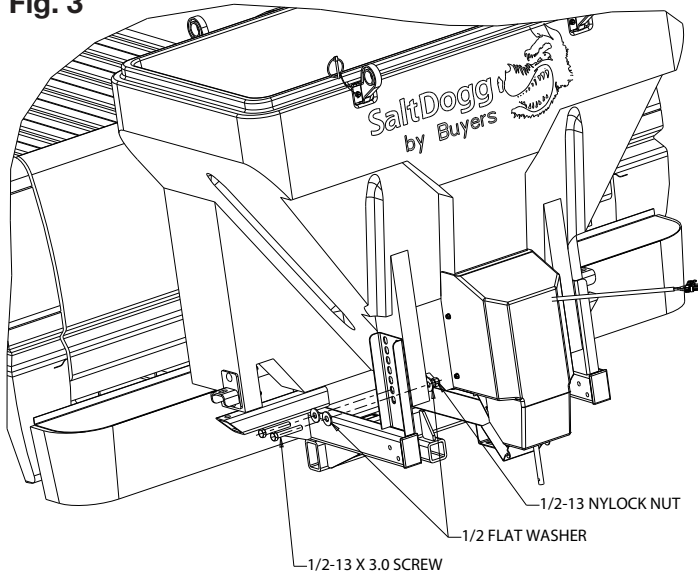

Fig. 2

3. Align holes in rear portion of the hopper with slots in frame uprights. Use slots which will position spreader with a slight upward tilt. Secure hopper assembly to frame using 1/2-13 x 3.0 screws, flat washers and nuts. Fig.3. Do not tighten fasteners at this time.

Fig. 3



WARNING
SPREADER CANNOT BE SUPPORTED BY FRAME ONLY!
SPREADER HOPPER MUST REST ON BUMPER OR SIMILAR STRUCTURE ATTACHED TO TRUCK FRAME.

4. Slide hopper and frame towards tailgate leaving about 3/8" to 1/2" space. Align closest holes in hitch receiver with holes in frame. Secure frame in hitch receiver using 5/8 hitch pin and cotter pin. Fig.4.

Fig. 4

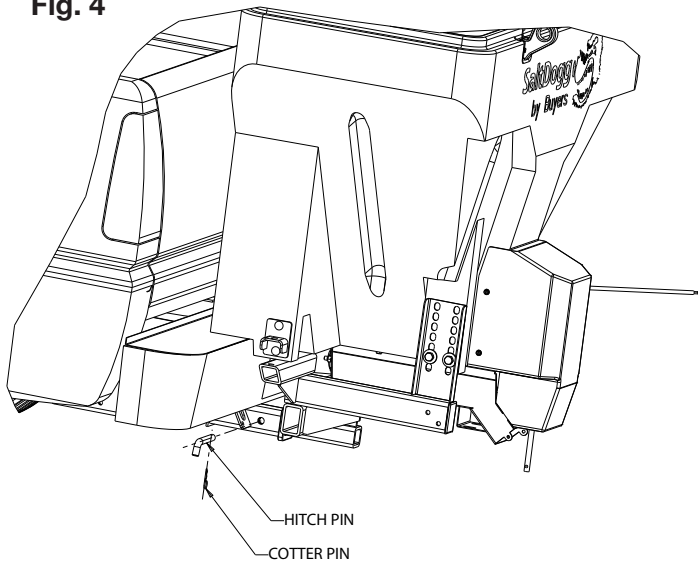

5. Assembly 1/2-13 x 6.0 screws with flat washers and 1/2-13 flanged nuts and nylock nuts as shown in Fig.5. Make sure that nuts located between hopper side brackets and frame positioned exactly as shown. These nuts must not be in contact with brackets and frame at this time.

Fig. 5

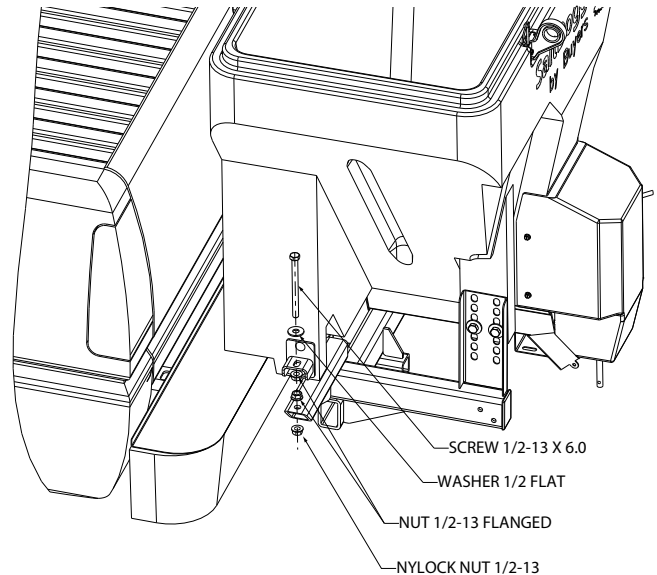

6. Tighten nuts located under frame evenly on both sides of the spreader (10-15 ft-lb's. torque). Then tighten bolts in frame uprights. Finally tighten nuts located between hopper side brackets and frame. They must look as shown in Fig.6. After this procedure spreader should be securely attached to trucks bumper and frame.

Fig. 6

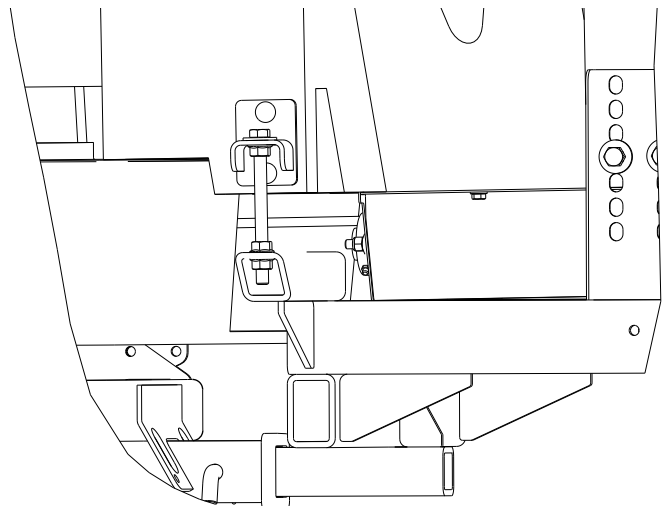

7. Attach shield #3015707 to trough bracket as shown in Fig.7

Fig. 7

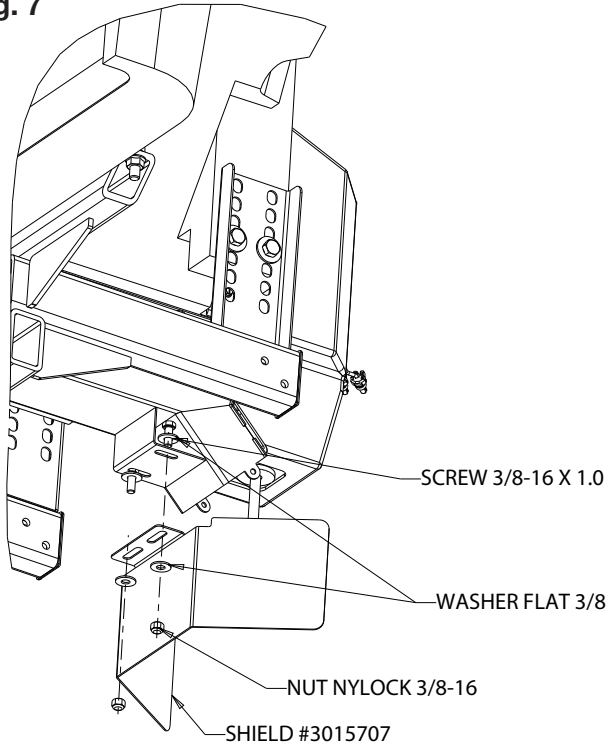

8. Attach spinner protector #3018923 to spreader frame as shown in Fig.8.

Fig. 8

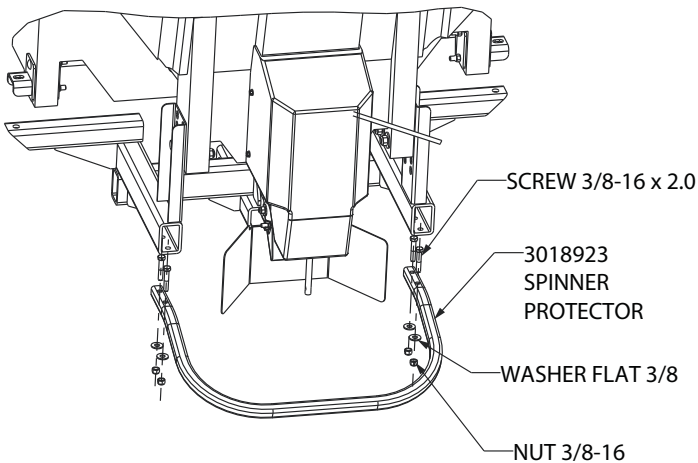

9. Attach spinner disk to gear motor shaft as shown in Fig.9. Secure disk on shaft using clevis pin and cotter pin.

Fig. 9

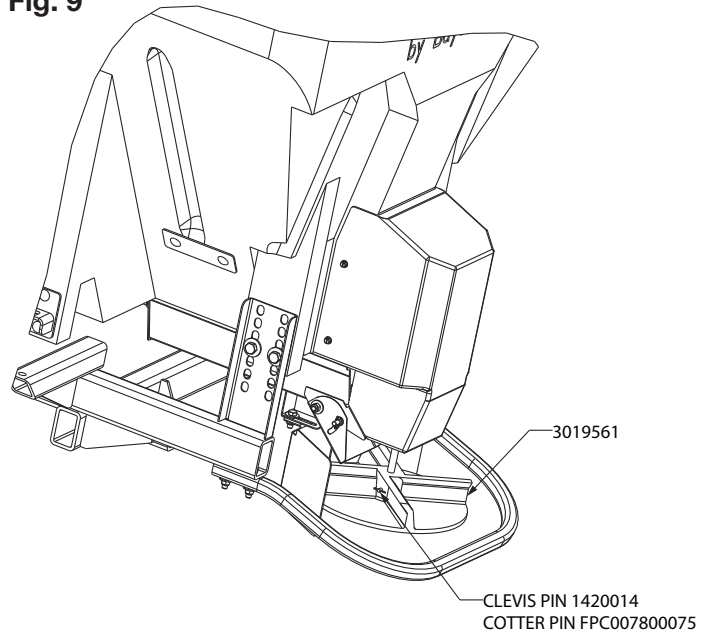

10. Install lid #3015926 on to hopper. Place lid on hopper. Bend hinges outward from center of the hopper. Slide hinges openings on round protrusions of the lid. Repeat this operation on opposite side of the hopper. Secure lid on hopper using lynch pin. To open lid from either side of the hopper disengage lynch pin, bend both hinges outwards and open lid.

Fig. 10

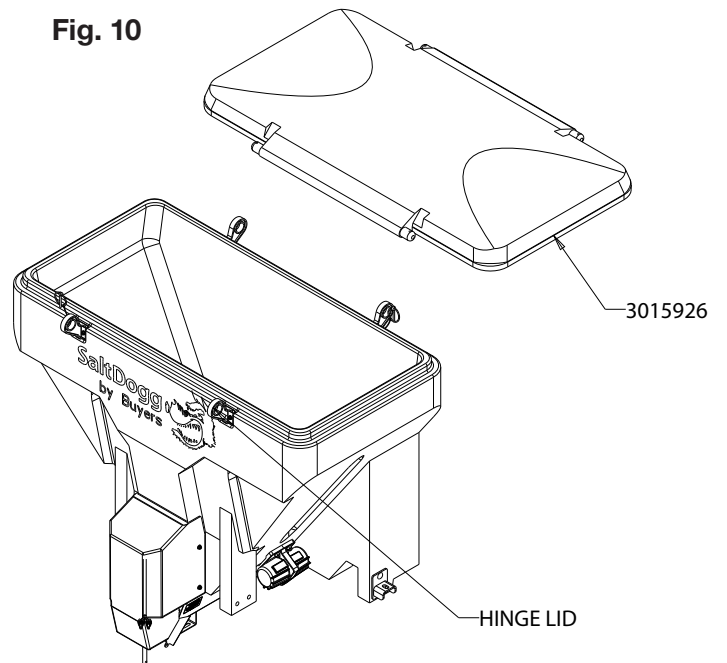

**THIS IS WIRE GROUND ELECTRICAL SYSTEM!
NO CONNECTIONS TO TRUCK'S FRAME OR BODY
ALLOWED!**

NOTE: Always disconnect battery before attempting to install electrical components on your vehicle.

Mount the controller in a convenient location in the truck cab. It is recommended not to mount the controller directly in front of heat vents. Allow ample air space around controller.

⚠ CAUTION

DO NOT MOUNT CONTROLLER IN THE WAY OF AIR BAG DEPLOYMENT!

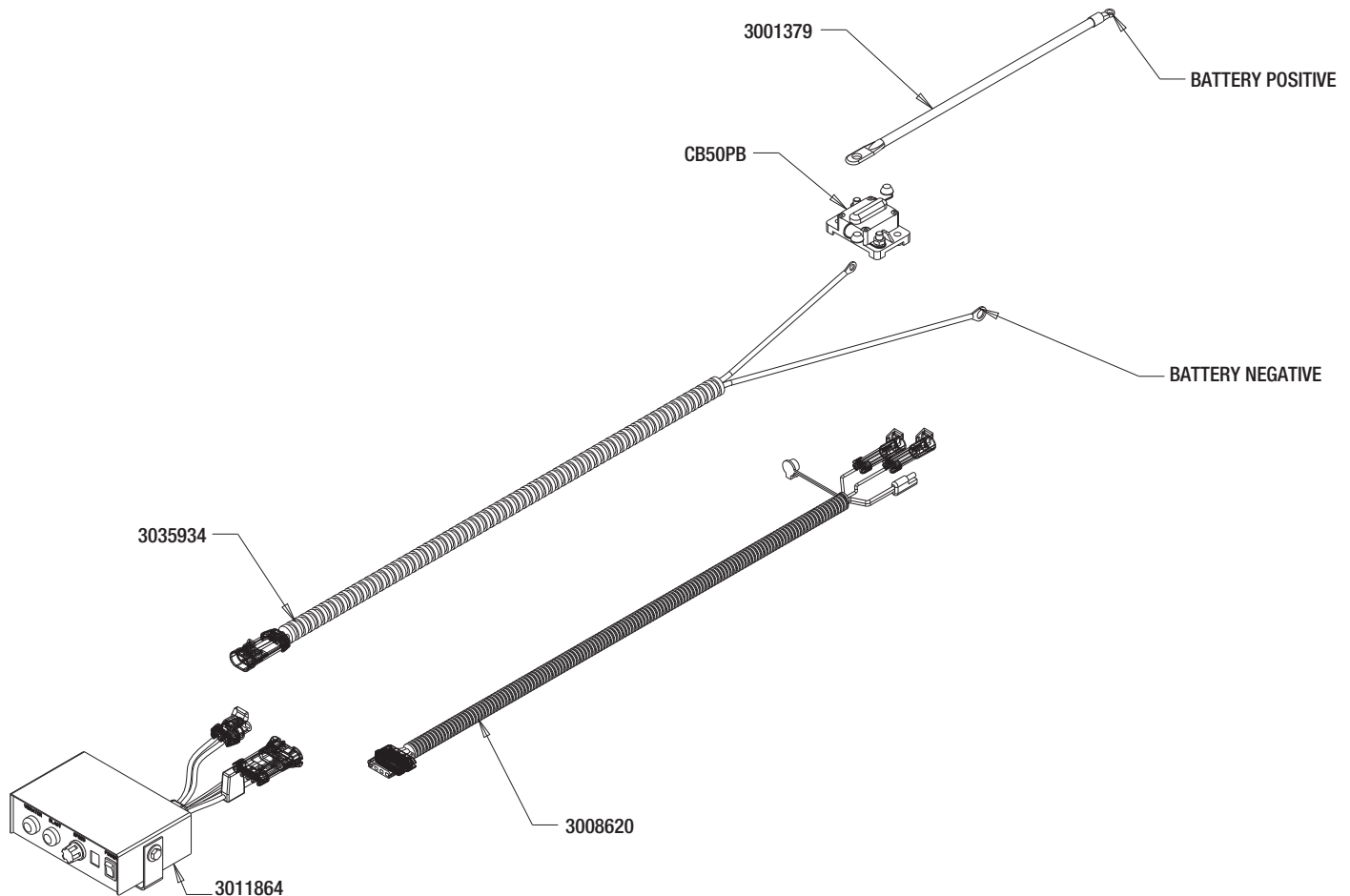

Installing Controller and Wiring

- Route both wire harnesses into truck cab through firewall (it maybe necessary to drill holes). Insulate hole to avoid water leaks.
- Insure no wires are nicked or damaged during installation.
- Connect the 4-pin connector on the wire harness to the control box.
- Connect the 2-pin connector on the power cable to the control box.
- Lay out a path for the power cable to the battery, use quick ties to secure power cable.

DO NOT CONNECT TO BATTERY AT THIS TIME!

- Lay out path for wire harness to the rear of the vehicle. It is recommended to stay clear of the exhaust system. Excess heat can damage the wire harnesses. Use quick ties to secure harness to underbody.
- Connect the wire harness to the motor and vibrator.
- Connect the power and ground cables directly to the battery.
- Insure all functions of the controller are working properly.
- **Note:** direction of spinner may be changed by interchanging the motor leads.

Spreader Operation.

1. Due to the rate at which materials absorb moisture differently, some materials may not perform as desired. Therefore, the substitution of an alternative material may be necessary for optimum performance.
2. When filling hopper use supplied screen to prevent large chunks of material and debris contained in the material to get into hopper and cause operational problem or damage.
3. Material must never be left in the hopper for extended period of time. Material will absorb moisture, bind, harden and may prevent spreader from proper operation or may damage the spreader.
4. To start spreader make sure that truck engine is running. Flip POWER switch in ON position. Switch will illuminate. Spreader motor will accelerate to full speed and then it will slow down to previously dialed speed.
5. To adjust material flow rate and spreading distance, simply rotate speed knob to desired speed. Spreader can be put in full speed mode for short time by pressing and holding BLAST button.
6. To activate and deactivate vibrator press VIBRATOR button.
7. In addition material flow rate can be controlled by adjusting inverted vee, located inside hopper. To reduce material flow, lower inverted vee towards auger. For slow and difficult to flow materials inverted vee can be raised or completely removed.
8. In addition, material flow and pattern can be adjusted by opening/ close adjustable discharge on the trough bottom.

Controller Warnings.

Check controller instruction sheet for latest controller updates, troubleshooting codes. Controller instruction sheet is inside controller shipping box.

IMPORTANT! INSTALLER, DO NOT DISCARD CONTROLLER INSTRUCTION SHEET. STAPLE SHEET TO SPREADER MANUAL AND GIVE TO END USER!

Maintenance Instructions.

1. Wash spreader after every use. Make sure no material left under auger and/or inside trough.
2. Inspect and retighten fasteners after every 5-7 hours of operation.
3. Lubricate bearing every 7-10 hours of operation using general automotive grease.
4. Inspect terminals/ connectors every time you disconnect spreader from wire harness. Apply thin layer of dielectric grease on terminals. If any tarnish/corrosion found, clean terminals and apply dielectric grease.

End of Season Maintenance.

1. Wash spreader. Make sure no material or residue left in and outside hopper.
2. Lubricate bearing using general automotive grease.
3. Inspect wire harness, connectors for broken insulation, missing components. Replace if necessary.
4. Apply dielectric grease on all electrical connectors.
5. Store hopper indoors, in dry, cool place.
6. Inspect, clean and repaint frame.
7. Remove controller from truck. Store controller indoors, in dry, cool place.

Tailgate Auger

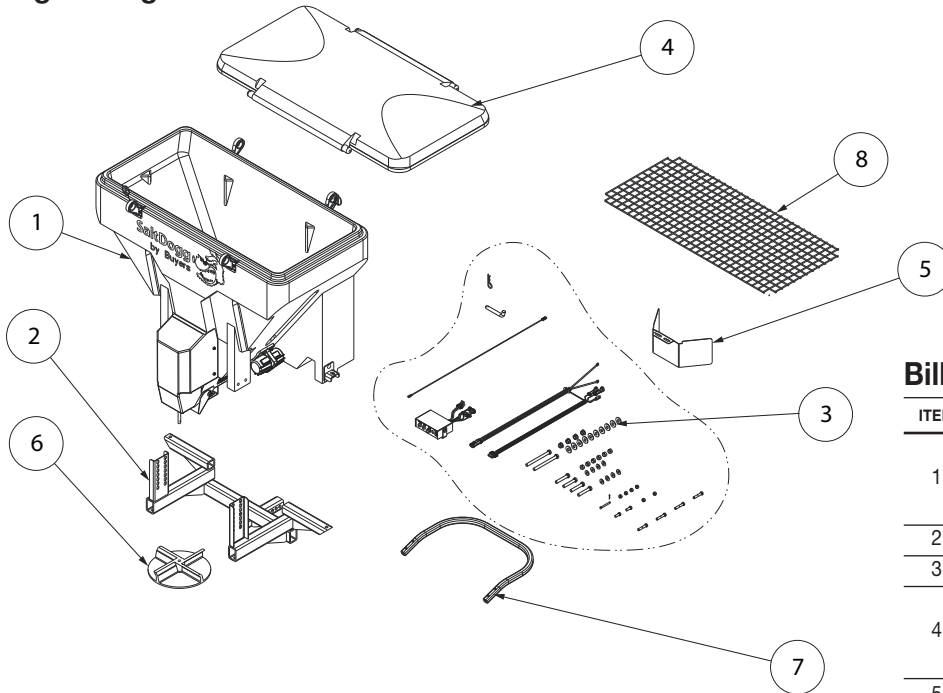

Bill of Materials

ITEM	PART NO.	QTY.	DESCRIPTION
	3015380	1	HOPPER ASSEMBLY, TGS07
1	3026561	1	HOPPER ASSEMBLY, RED
	3026563	1	HOPPER ASSEMBLY, YELLOW
2	3015859	1	FRAME, HITCH MOUNT
3	3020207	1	HARDWARE BOX TGS07
	3015926	1	LID, TGS07
	3026566	1	LID, RED
4	3026567	1	LID, YELLOW
	3015707	1	SHIELD TGS07
6	3019561	1	SPINNER, 12 IN TGS
7	3018923	1	DISC PROTECTOR
8	3018781	1	SCREEN TGS07

TGS07 Hopper Assembly

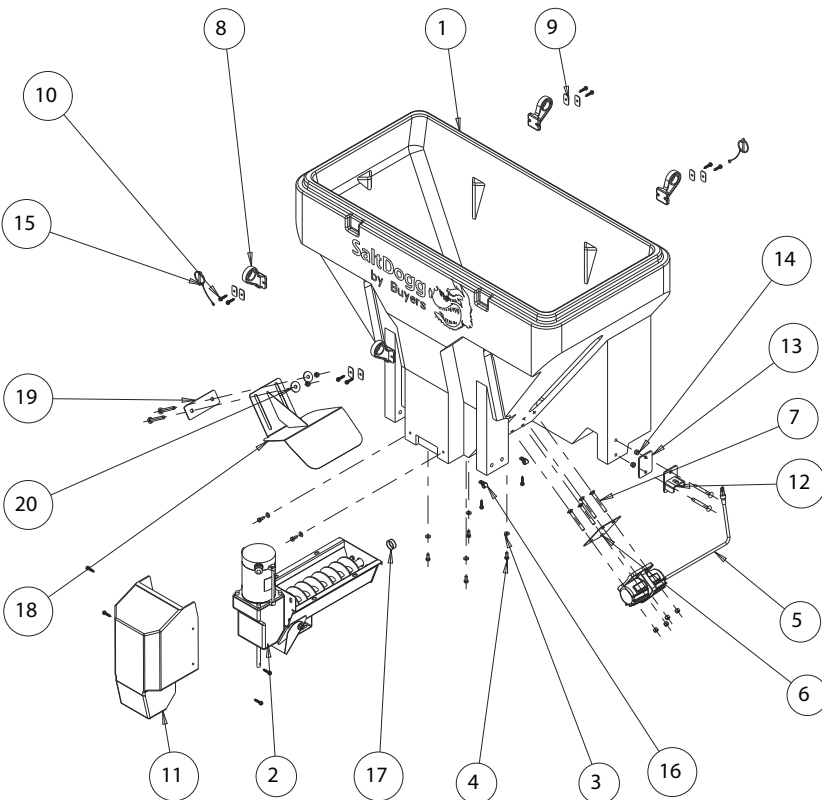

Bill of Materials

ITEM	PART NO.	QTY.	DESCRIPTION
	3015379	1	HOPPER TGS07
1	3026560	1	HOPPER, RED
	3026562	1	HOPPER, YELLOW
2	3015383	1	TROUGH ASSEMBLY TGS07
3	FWF031075006SS	6	WASHER, 5/16 SAE SST
4	3006721	6	SCREW, HEX HD, 5/16-18 X 3/4 GR5 S
5	3007416	1	VIBRATOR 200 LBS 12 VDC
6	3017030	1	RETAINER, VIBRATOR
7	3017028	10	BOLT, CRG, 3/8-16x3.25 SST
8	3016021	4	HINGE, LID TGS07
9	3016983	8	RETAINER, HINGE
10	3015925	14	SCREW #14X1.25 SST
11	3015694	1	MOTOR COVER TGS07
12	3016670	2	BRACKET DRAW, WELDMENT
13	3017029	2	RETAINER, DRAW BRACKET
14	FNE038016044SS	10	NUT, NYLOCK 3/8-16 X 7/16 SST
15	3016979	2	PIN, 3/16 LYNCH
16	4375	2	CLAMP, HOSE .4375, 9/32 HOLE
17	3017984	1	CAP ROUND 1.312 ID VINYL BLACK
18	3018773	1	BAFFLE WELDMENT TGS07
19	3018922	1	RETAINER, BAFFLE
20	3007115	2	WASHER, FLAT 3/8 X 1.5 X.048 SST

TGS07 Trough Assembly

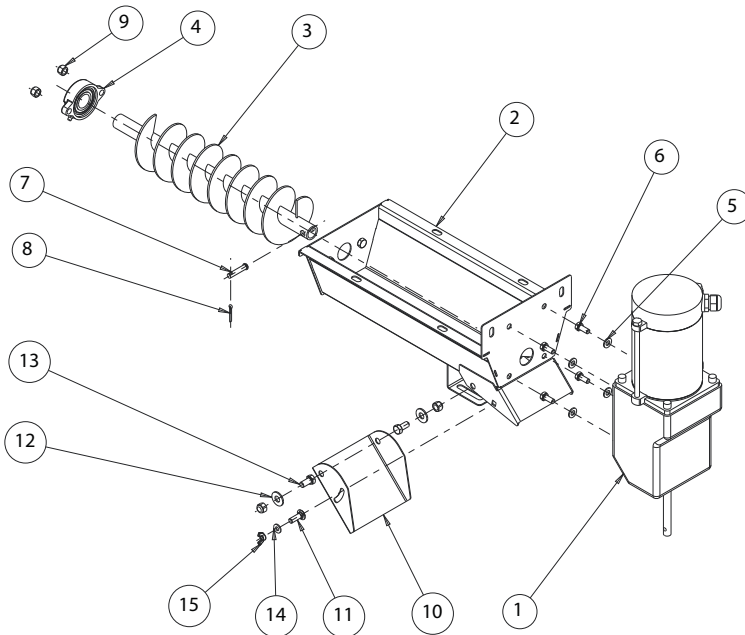

Bill of Materials

ITEM	PART NO.	QTY.	DESCRIPTION
1	3015377	1	GEAR MOTOR DUAL SHAFT .5 HP 12 VDC
2	3015381	1	TROUGH WELDMENT, TGS07
3	3015382	1	AUGER TGS07
4	1411000	1	BEARING, 2-HOLE FLANGED 1"
5	FWF031075006SS	4	WASHER, 5/16 SAE SST
6	3006721	4	SCREW, HEX HD, 5/16-18 X 3/4 GR5 SS
7	FPY031000150	1	PIN, CLEVIS, 5/16 X 1-1/2, W/ 5/32 PH, ZN
8	3014994	1	PIN, COTTER, 1/8IN X 1IN SST
9	FNE038016044SS	4	NUT, NYLOCK 3/8-16 X 7/16 SST
10	3019374	1	DISCHARGE, ADJUSTABLE
11	3012144	1	BOLT, RHSQN., 25-20X.5 SST
12	FWF038100007SS	2	WASHER, FLAT 3/8 USS SST
13	FCS038016075SS	2	SCREW, HHC-3/8-16 X 3/4 SST
14	FWF025063007SS	1	WASHER, FLAT 1/4 SAE SS
15	3016751	1	NUT, WING 1/4-20 SST

TGS07 Hardware Box

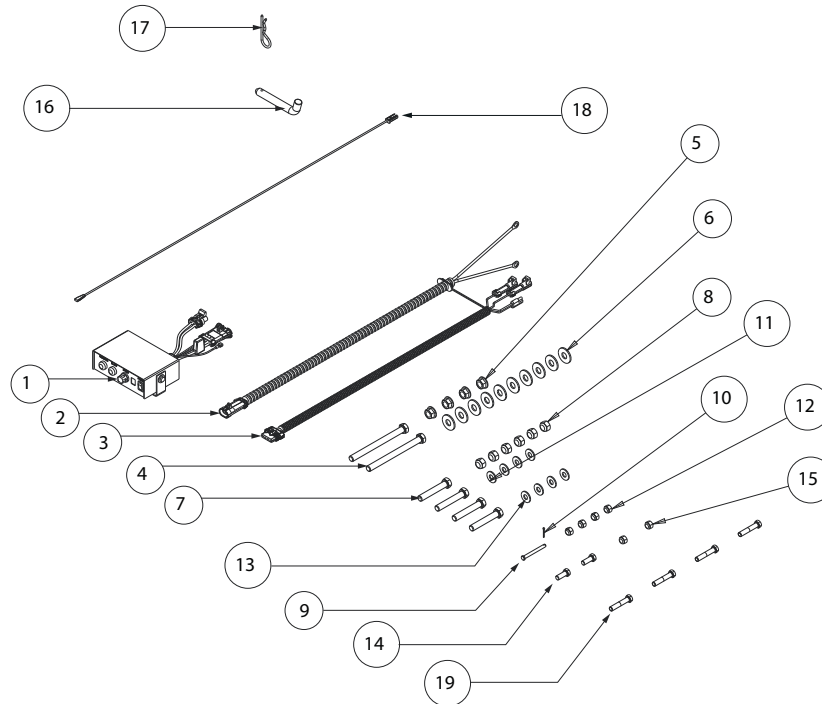

Bill of Materials

ITEM	PART NO.	QTY.	DESCRIPTION
1	3011864	1	CONTROLLER TGS W/ VIBRATOR SWITCH
2	3035934	1	WIRE HARNESS, POWER TGS
3	3008620	1	WIRE HARNESS MAIN W/ VIBRATOR, TGS
4	3017039	2	SCREW, HEX HEAD CAP 1/2-13 X 6.00 SST FULL THREAD
5	3035934	4	NUT, HX FLNG-1/2-13 SST
6	3000269	10	WASHER, FLAT 1/2 USS, SST
7	3001250	4	SCREW, HHC-1/2-13 X 3 SST
8	FNE050013053SS	6	NUT, NYLOCK 1/2-13 SS
9	1420014	1	PIN CLEVIS, 1/4 X 2.5
10	FPC007800075	1	COTTER PIN, 5/64 X 3/4

ITEM	PART NO.	QTY.	DESCRIPTION
11	FWF038100007	4	WASHER, FLAT 3/8 USS ZINC
12	FNE038016044	4	NUT, NYLOCK 3/8-16 X 7/16 ZINC
13	FWF038100007SS	4	WASHER, FLAT 3/8 USS SST
14	FCS038016100SS	2	SCREW, HHC 3/8-16 X 1 304 SST
15	FNE038016044SS	2	NUT, NYLOCK 3/8-16 X 7/16 SST
16	HP6253WC1	1	PIN, 5/8 HITCH
17	HP12	1	PIN, HAIR COTTER 5/32" ZN 3.25 OAL
18	3001379	1	BATTERY CABLE
19	FCS038016200	4	SCREW, HHC 3/8-16 X 2 GR 5 ZP
	3018421	1	ANTI SEIZE LUBRICANT POUCH 5 GRAMM
	CB50PB	1	CIRCUIT BREAKER