

**IF YOU ARE EXPERIENCING TROUBLE WITH THIS PRODUCT,  
OR MISSING PARTS, PLEASE CALL 800-954-3310 FOR ASSISTANCE  
DO NOT RETURN TO STORE**

# Max LINE

**M7500 3/4" MASTER KIT**

## INSTALLATION INSTRUCTIONS

### PLANNING/LAYOUT

Before beginning the installation, create a plan as to the location of the air compressor and where you are going to mount the compressed air outlets. On the plan locate outlets, tees, and elbows if needed.

### AIR COMPRESSOR

Use a flexible jumper hose from the air compressor to the filter regulator unit to reduce vibration to the Maxline tubing.

### FILTER REGULATOR

Maxline tubing is resistant to most common petroleum based compressor oils. Some new synthetic oils will reduce the life of the tubing. A high quality filter regulator is recommended to catch oils entering the air system.

### RATINGS

200 psi at 73°F • 160 psi at 140°F • ASTM F1282

### BENDING THE TUBING

The Maxline tubing can be bent to hold any shape. Care should be taken not to kink the tubing, but rather bend the tubing in a sweeping radius around corners and obstacles. Elbow fittings are available for sharp corners.

### ASSEMBLY OF THREADED COMPONENTS

Assemble all NPT threads with two wraps of teflon tape and then PIPE SEALANT which prevents thread galling.

### TUBING INSTALLATION

Maxline tubing will expand and contract slightly with changes in temperature. Use supplied wall clips spaced every 5 ft.

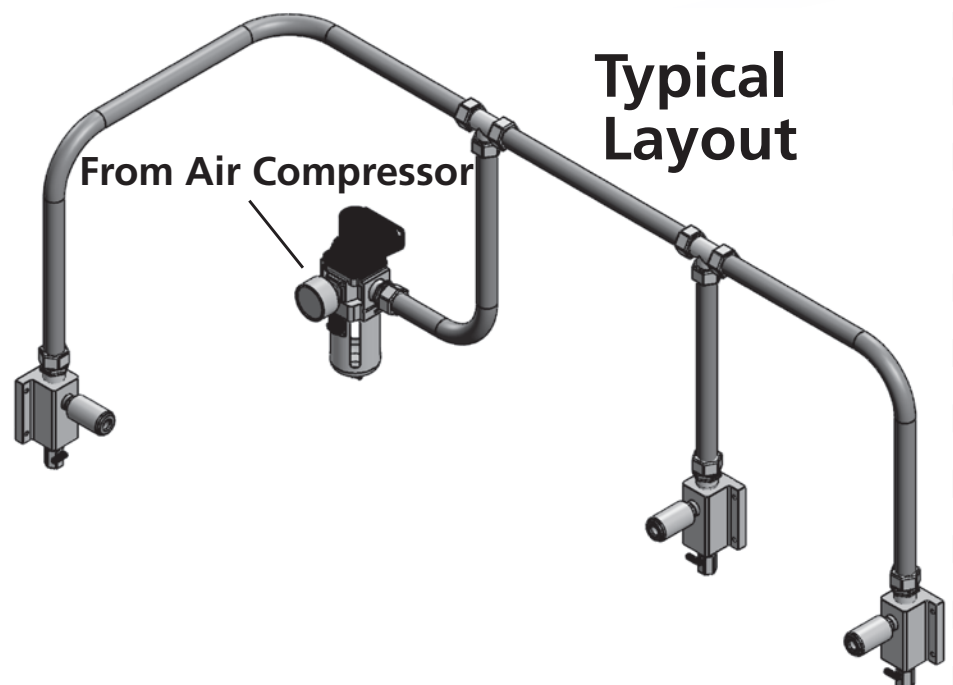

# Tools and installation



**1)** CUT the tubing square with the cutter, **ROTATING** wrist while cutting



**2)** BEVEL the inside of the tubing by inserting the reaming tool and rotating it at least 3 full turns

- Use peg #25 for 3/4" tubing  
Remove nut and split ring from fitting and place on tubing



**3)** PUSH the fitting onto the tubing and fully **against the shoulder** of the fitting (soapy water will help this process)



**4)** TURN the nut finger tight  
Put a reference mark on the nut and fitting body

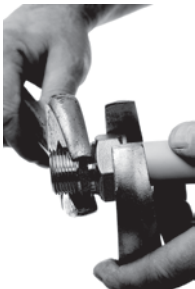

**5)** TIGHTEN nut with wrench a minimum 3/4 of a turn or until tight



## M7500 MASTER KIT PARTS LIST

- 100ft 3/4" Maxline Tubing
- (3) M81010 Aluminum Blocks
- (3) M8005 3/4" Tubing x 1/2" NPT fittings
- (3) 50136 1/2" npt Plugs
- (3) 50120 3/8" npt Drain Valves
- (1) M8003 3/4" Tubing x 3/4" NPT Fitting
- (2) M8011 Tee Fittings
- (20) Tubing Clips
- Cutter and Bevel Tool



Front of block is ported  
1/2" NPT Female

Coupler Not Included

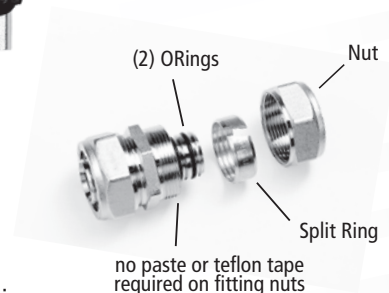

## WARNINGS

- Regulate system pressure to a maximum of 200 psi.
  - Pressurize system slowly
  - Turn off air compressor when not in use
- Check local building codes before installation.
- Compressed air is dangerous if not used properly.
- Do not point compressed air source at any part of your body or at any person.
  - Always use eye protection when using compressed air.
- CA PROP 65: This product contains chemicals, including lead, known to the State of California to cause birth defects or other reproductive harm. **Wash hands after handling.**

**CONTAINS LEAD: MAY BE HARMFUL IF EATEN OR CHEWED. MAY GENERATE DUST CONTAINING LEAD. KEEP OUT OF THE REACH OF CHILDREN.**

**Engineered Specialties, LLC • Auburndale, WI • 800-954-3310**  
For installation tips and warranty information, please visit [www.RapidAirproducts.com](http://www.RapidAirproducts.com)