

DOUBLE DEPTH STORAGE BUILDING - STOR-912-G-W-1RH

APPROX WEIGHT: 1287.16 lbs.
 DOES NOT INCLUDE WEIGHT OF POWER OR PACKAGING!!!

*** ANY ADDITIONS, DELETIONS, OR OMISSIONS MUST BE CORRECTED ON THIS DRAWING AS THIS DRAWING WILL BE CONSIDERED ALL INCLUSIVE ***

ALL GRAPHICS PROVIDED ARE FOR REFERENCE ONLY. IF CERTAIN DIMENSIONS ARE CRITICAL PLEASE VERIFY THOSE DIMENSIONS WITH YOUR SALESPERSON

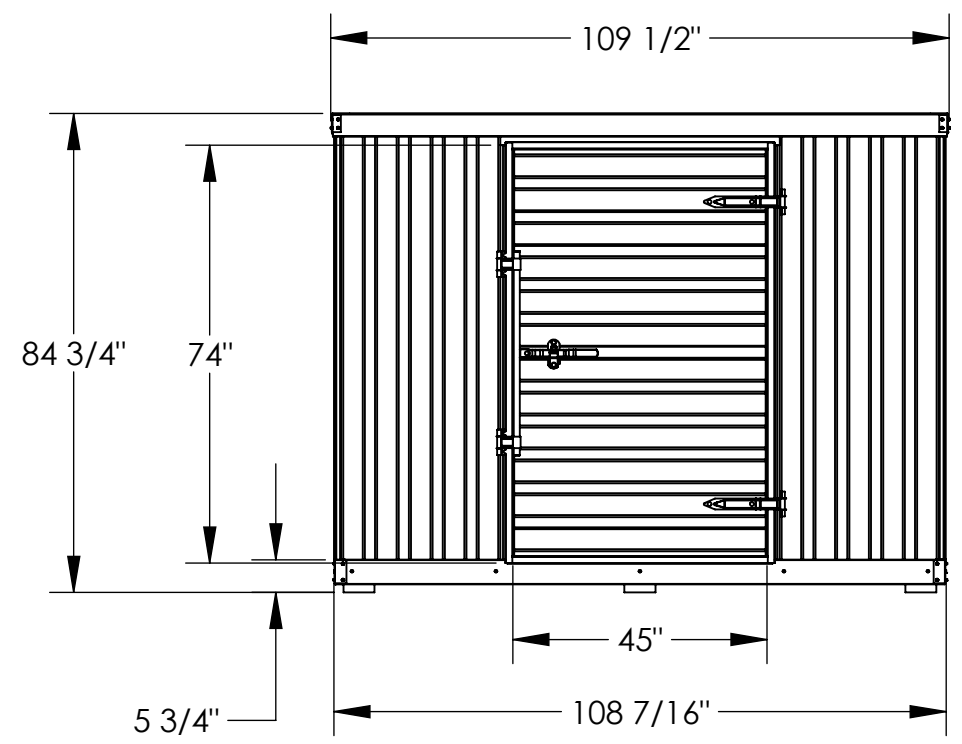
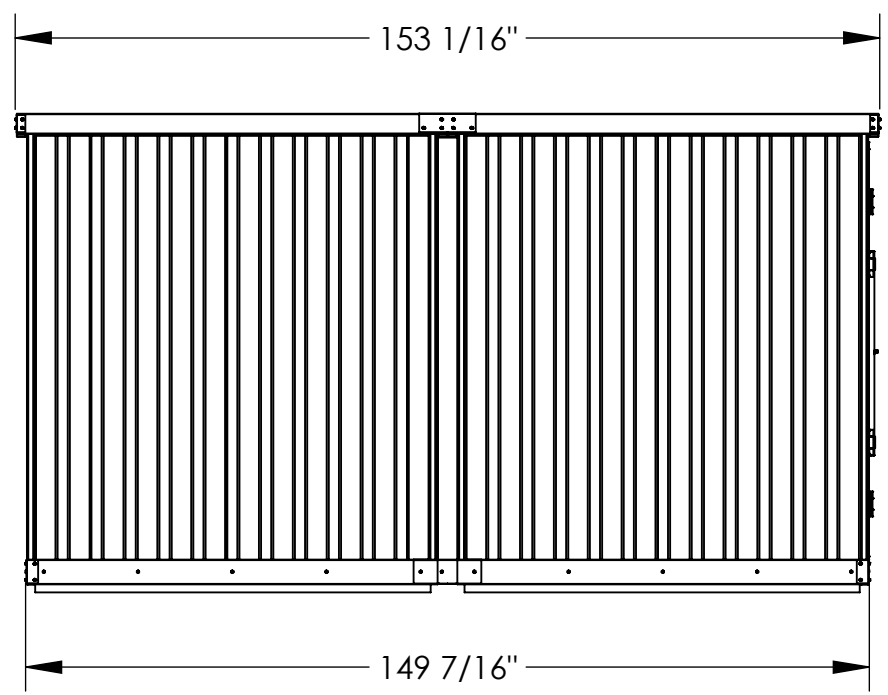

DIMENSION TOLERANCE ± 1/4"

STANDARD FEATURES

- MODEL NUMBER IS: STOR-912-G-W-1RH
- UNIFORM CAPACITY OF FLOOR IS 5,500 LBS
- OVERALL WIDTH IS 109 1/2"
- USABLE INSIDE WIDTH IS 104 11/16" (NOT SHOWN)
- OVERALL DEPTH IS 153 1/16"
- USABLE INSIDE DEPTH IS 145 11/16" (NOT SHOWN)
- 106 SQ-FT USABLE FLOOR SPACE
- OVERALL HEIGHT IS 84 3/4"
- USABLE INTERIOR HEIGHT IS 77 3/8" (NOT SHOWN)
- USABLE DOOR OPENING IS 45" W x 74" H
- WOODEN FLOOR HEIGHT IS 5 3/4" H
- ROOF SNOW LOAD RATING: 45 LBS / SQ-FT
- MAINTENANCE FREE GALVANIZED STEEL CONSTRUCTION
- SHIPS KNOWCKED DOWN, ASSEMBLY REQUIRED

SPECIAL FEATURES

NONE

APPROVAL	I, THE UNDERSIGNED, AGREE THAT THE PRODUCT AS REPRESENTED SATISFIES DESIGN AND DIMENSION REQUIREMENTS. I ALSO ACKNOWLEDGE MY DUTY TO CONFIRM PRODUCT AND INSTALLATION COMPLIANCE WITH ALL APPLICABLE FEDERAL, STATE AND LOCAL REGULATIONS AND STANDARDS.	
	UNITS REQUIRING APPROVAL DRAWINGS OR MODIFIED ARE NON-RETURNABLE	
	[] As drawn [] As marked	
Signed: _____		Date: _____
Printed Name: _____		
<i>LEAD TIME WILL START UPON RECEIPT OF SIGNED APPROVAL DRAWING</i>		

DISTRIBUTOR'S NAME:		P.O.#
VESTIL MANUFACTURING		X
		W.O.#
DRAWN BY: ND	DATE: 12/23/11	SALES: X
REFERENCE: X	SCALE: 1:34	FILE NAME:
QUOTED LEAD TIME: X	QUOTE # X	41-007-007