

# 2005 Owner's Manual

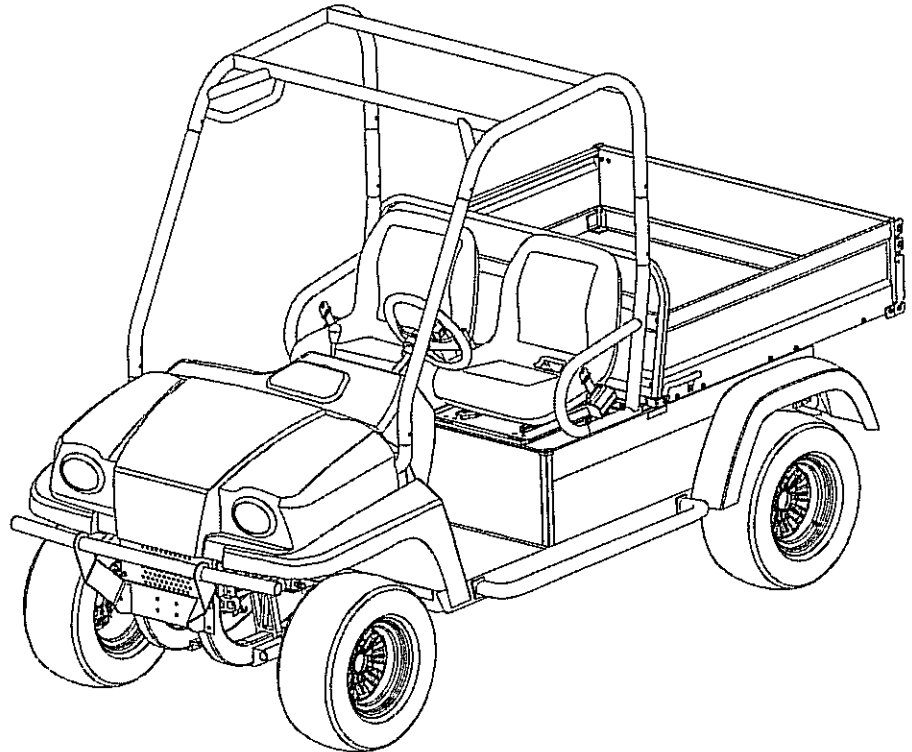

## **HUV4420 and HUV4420-D Gasoline and Diesel Vehicles**





## NOTICE

---

The Husqvarna® Limited Two Year Warranty for 2005 Transportation and Utility Vehicles and California Emission Control Warranty Statement appear on the last pages of this manual. No other warranties, express or implied, are contained herein. Your authorized representative checked the vehicle before it was delivered to you and will provide you a copy of the completed vehicle warranty registration form.

Husqvarna is not liable for errors in this manual or for incidental or consequential damages that result from the use of the material in this manual.

This manual contains proprietary information that is protected by copyright. All rights are reserved. No part of this manual may be photocopied, reproduced, or translated to another language without the written consent of Husqvarna.

The information contained in this document is subject to change without notice.

Husqvarna reserves the right to change specifications and designs at any time without notice and without the obligation of making changes to units previously sold.

These vehicles do not conform to Federal Motor Vehicle Safety Standards for automobiles or to FMVSS 500 for low-speed vehicles, and are not equipped for operation on public streets, roads, or highways.



Husqvarna Forest and Garden  
7349 Statesville Rd.  
Charlotte, NC 28269  
USA  
[www.usa.husqvarna.com/huv](http://www.usa.husqvarna.com/huv)

## FOREWORD

---

Thank you for choosing Husqvarna, a world leader in outdoor products. You have chosen the finest utility vehicle on the market. Please protect your investment and ensure that your Husqvarna vehicle provides years of reliable, superior performance by reading and following the maintenance instructions in this manual.

Your comfort and safety are important to us, so we urge you to read and follow the step-by-step operating instructions and safety precautions in this manual. These instructions must be followed in order to avoid the risk of severe personal injury. If you rent or loan your vehicle to others, we recommend that you ask them to read this manual before they operate the vehicle.

Husqvarna products are backed by a customer support system designed to offer you fast, courteous service. In the event that your Husqvarna vehicle needs repairs or service, we recommend that your local authorized Husqvarna representative perform them. For the name and address of the Husqvarna representative nearest you, logon to our web site at [www.usa.husqvarna.com](http://www.usa.husqvarna.com). If you would prefer to write to us, direct your letter to: Husqvarna, Attention: Marketing Services, 7349 Statesville Rd., Charlotte, NC 28269 USA. Your local authorized Husqvarna representative can also provide technical advice, parts, and service manuals.

We hope you will consider this owner's manual a permanent part of your Husqvarna vehicle. If you sell the vehicle, please include the manual so that the next owner will have the important operating, safety, and maintenance information it contains. Translated owner's manuals can be downloaded from the Husqvarna web site at [www.usa.husqvarna.com/huv](http://www.usa.husqvarna.com/huv).

## TABLE OF CONTENTS

---

Safety Decal Identification – Gasoline Vehicles .....	4
Safety Decal Identification – Diesel Vehicles .....	6
Safety Details .....	9
General Warnings .....	10
Model Identification .....	12
Controls and Indicators .....	12
Roll-over Protective Structure (ROPS) and Safety Belts .....	17
Seat Latch and Adjustment .....	19
Pre-Operation and Daily Safety Checklist .....	19
Driving Instructions .....	20
Front Shock Absorbers .....	23
Loading and Unloading .....	24
Towing with the Vehicle .....	25
Transporting on a Trailer .....	25
Storage .....	26
Maintenance .....	28
Periodic Service Schedule .....	29
Periodic Lubrication Schedule .....	32
Brake Fluid Reservoir .....	34
Engine Oil .....	34
Gearcase Lubrication .....	39
Engine Coolant – Diesel Vehicles .....	40
Air Intake System .....	40
Fueling Instructions .....	41
Battery .....	43
Cleaning the Vehicle .....	45
Vehicle Specifications .....	47
Husqvarna® Limited Two Year Warranty for 2005 Transportation and Utility Vehicles .....	49

# GASOLINE VEHICLES

**UNDERAGE WARNING DECAL**

**CERTIFICATION NOTICE AND WARNING DECAL**

**DRIVER/PASSENGER WARNING DECAL**

**BED LOAD WARNING DECAL**

**ROTATING PARTS WARNING DECAL (ON PASSENGER-SIDE VEHICLE FRAME)**

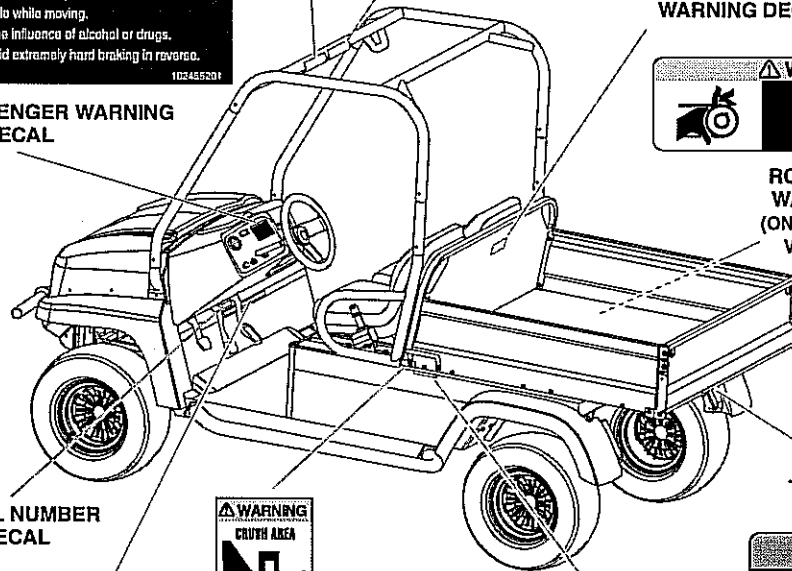

**SERIAL NUMBER DECAL**

**CRUSH AREA DECAL (ON DRIVER-SIDE AND PASSENGER-SIDE)**

**BED LATCH WARNING DECAL (ON REAR RECEIVER HITCH)**

**TRAILER HITCH DECAL**

**VEHICLE LOADING DECAL**

<b>VEHICLE LOADING</b> Read owner's manual and warnings on dash.	• Maximum gross vehicle weight: 2750 lb. (1247 kg) • Maximum cargo load: 800 lb. (363 kg) • Includes cargo bed load and gross trailer weight. • Maximum cargo load is reduced by the weight of optional equipment. • Maximum trailer hitch tongue weight: 150 lb. force (667 N).	• PREVENT VEHICLE ROLL-OVER. • Place cargo forward in the cargo bed and distribute evenly side to side. Secure load. • On uneven or steep terrain reduce speed and load. Avoid stopping on or backing down steep hills. • Avoid top heavy loads. See owner's manual. CCI 102182301
	(STANDARD VEHICLE)	

<b>HIGH-CAPACITY VEHICLE LOADING</b> Read owner's manual and warnings on dash.	• Maximum gross vehicle weight: 3012 lb. (1366 kg) • Maximum cargo load: 1050 lb. (476 kg) • Includes cargo bed load and gross trailer weight. • Maximum cargo load is reduced by the weight of optional equipment. • Maximum trailer hitch tongue weight: 150 lb. force (667 N).	• PREVENT VEHICLE ROLL-OVER. • Place cargo forward in the cargo bed and distribute evenly side to side. Secure load. • On uneven or steep terrain reduce speed and load. Avoid stopping on or backing down steep hills. • Avoid top heavy loads. See owner's manual. CCI 102153601
	(HIGH CAPACITY OPTION)	

# GASOLINE VEHICLES

## GASOLINE WARNING DECAL



(ON PASSENGER SIDE SEAT SUPPORT)

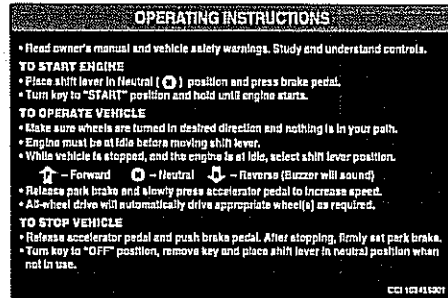

OPERATING INSTRUCTIONS  
(ON PANEL BETWEEN SEATS OR ON OPTIONAL CONSOLE/CUP HOLDER)

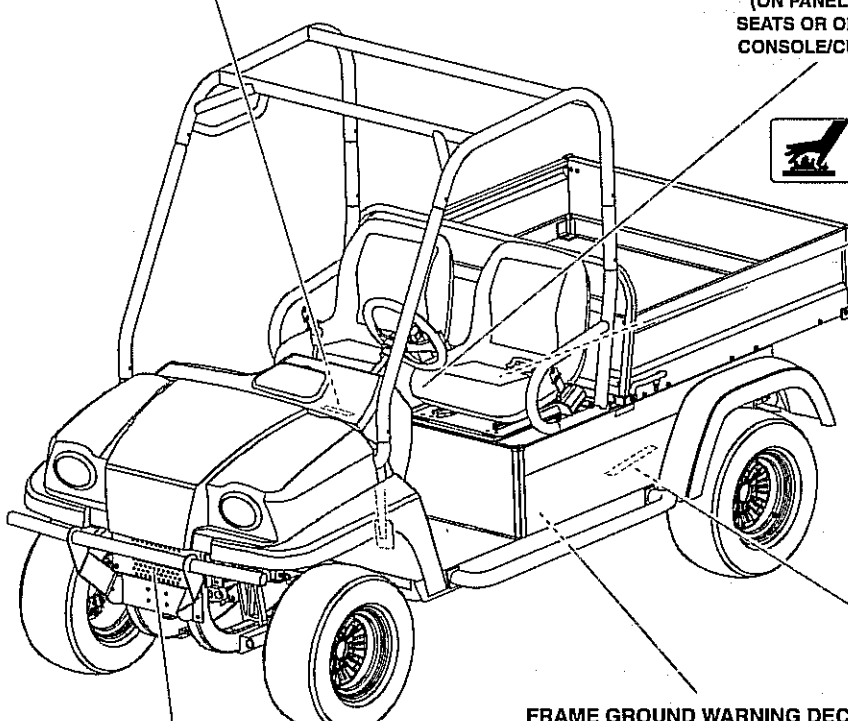

HOT SURFACE WARNING DECAL (3)  
(ON UNDERSIDE OF EACH SEAT AND ON CROSSBAR BEHIND SEATS)

FRAME GROUND WARNING DECAL  
(ON VEHICLE FRAME)

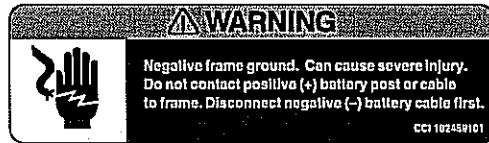

WINCH CABLE WARNING DECAL  
(FOR VEHICLES WITH WINCH ACCESSORY)



(ON FRONT BODY)

ROTATING PARTS AND HOT MANIFOLD WARNING DECAL  
(ON DRIVER-SIDE VEHICLE FRAME)

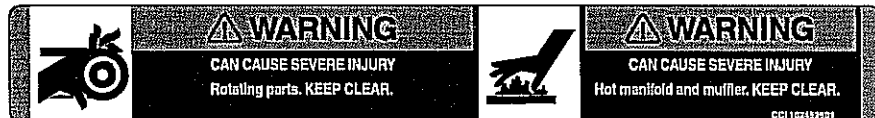

# DIESEL VEHICLES

**UNDER 16**

**WARNING**  
**YOUNG DRIVERS INCREASE CHANCE OF DEATH**  
 • Young drivers may not be able to control vehicle.  
 • No drivers younger than 16 years old.  
 • Do not leave children unattended on vehicle. CCI 102440401

**UNDERAGE WARNING DECAL**

**WARNING**  
 Club Car, Inc.  
 Augusta, Georgia, USA  
 Roll-over Protective Structure (ROPS)  
 ROPS per ISO 3471, BAE J1043,  
 AS 2294-1, and CSA 3352-2  
 Certified for vehicle models: Carryall 294,  
 XRT 1500, HUV4420, and Bubcat 8500  
 Max. undriven vehicle mass: 2034 lb. (923 kg)

**WARNING**  
 • Do not modify or remove Roll-over Protective Structure (ROPS).  
 • Replace ROPS if damaged. Do not attempt repair.  
 • Use seat belts during operation. Do not jump from vehicle.  
 • Keep away from drop-offs, steep slopes, and unstable surfaces. CCI 10244141

**CERTIFICATION NOTICE AND WARNING DECAL**

**WARNING**  
**ROLLOVER OR FALLING OFF MAY CAUSE DEATH**

- Read owner's manual and operating instructions.
- Fasten seat belts and remain seated while moving.
- Children requiring a child safety seat must not ride on vehicle. Comply with state and local laws pertaining to child safety.
- Drive slowly in turns and straight up and down slopes.
- Do not start vehicle until all occupants are seated.
- Front seats: One (1) person per seat maximum.
- Operate from driver side only and not on public roads.
- Keep entire body inside vehicle while moving.
- Do not operate while under the influence of alcohol or drugs.
- Never attempt jumps and avoid extremely hard braking in reverse.

102455301

**DRIVER/PASSENGER WARNING DECAL**

**WARNING**  
 Riding in cargo bed can cause severe injury or death. Do not ride in cargo bed. CCI 10154301

**BED LOAD WARNING DECAL**

**WARNING**  
 Rotating Parts CCI 10224001

**ROTATING PARTS DECAL (TOP OF PASSENGER-SIDE VEHICLE FRAME)**

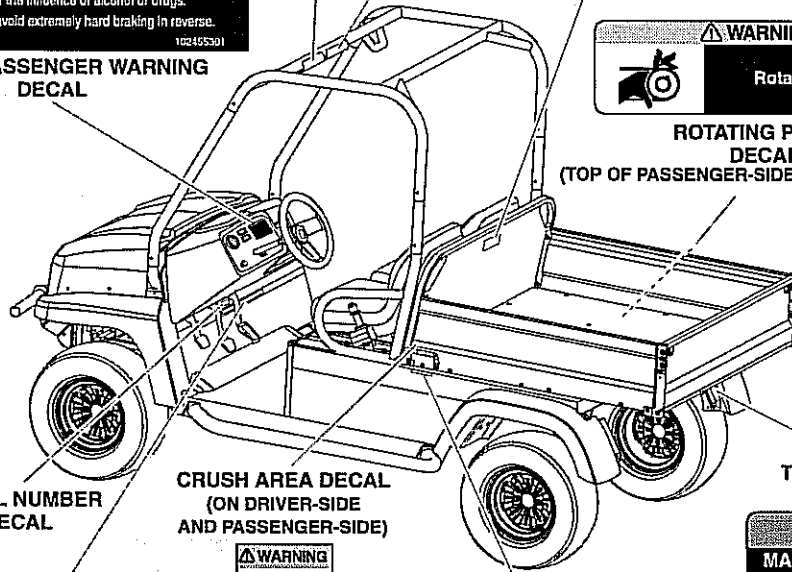

**SERIAL NUMBER DECAL**

**CRUSH AREA DECAL (ON DRIVER-SIDE AND PASSENGER-SIDE)**

**WARNING**  
**CRUSH AREA**  
 STAY CLEAR CCI 101509401

**TRAILER HITCH DECAL**

**NOTICE**  
**MAXIMUM TONGUE WEIGHT - 150 lbs.**  
 CCI 1011553

**BED LATCH WARNING DECAL**

**(ON REAR RECEIVER HITCH)**

**WARNING**  
 Crush area. Can cause severe injury. Stay clear when closing bed. CCI 10244001

**VEHICLE LOADING DECAL**

**VEHICLE LOADING**  
 Read owner's manual and warnings on dash.

- Maximum gross vehicle weight: 2750 lb. (1247 kg)
- Maximum cargo load: 800 lb. (363 kg)
- Includes cargo bed load and gross trailer weight.
- Maximum cargo load is reduced by the weight of optional equipment.
- Maximum trailer hitch tongue weight: 150 lb. force (667 N).

**PREVENT VEHICLE ROLL-OVER.**

- Place cargo forward in the cargo bed and distribute evenly side to side. Secure load.
- On uneven or steep terrain reduce speed and load. Avoid stopping on or backing down steep hills.
- Avoid top heavy loads. See owner's manual. CCI 102442001

**(STANDARD VEHICLE)**

**HIGH-CAPACITY VEHICLE LOADING**  
 Read owner's manual and warnings on dash.

- Maximum gross vehicle weight: 3012 lb. (1366 kg)
- Maximum cargo load: 1050 lb. (476 kg)
- Includes cargo bed load and gross trailer weight.
- Maximum cargo load is reduced by the weight of optional equipment.
- Maximum trailer hitch tongue weight: 150 lb. force (667 N).

**PREVENT VEHICLE ROLL-OVER.**

- Place cargo forward in the cargo bed and distribute evenly side to side. Secure load.
- On uneven or steep terrain reduce speed and load. Avoid stopping on or backing down steep hills.
- Avoid top heavy loads. See owner's manual. CCI 102443001

**(HIGH CAPACITY OPTION)**

# DIESEL VEHICLES

## DIESEL WARNING DECAL



(ON PASSENGER-SIDE SEAT SUPPORT)

**OPERATING INSTRUCTIONS**

- Read owner's manual and vehicle safety warnings. Study and understand controls.

**TO START ENGINE**

- Place shift lever in Neutral (N) position and press brake pedal.
- To check glow plugs, turn key to "PREHEAT" position and hold for 10-15 seconds.
- Turn key to "START" position and hold until engine starts.

**TO OPERATE VEHICLE**

- Make sure wheels are turned in desired direction and nothing is in your path.
- Engine must be at idle before moving shift lever.
- While vehicle is stopped, and the engine is at idle, select shift lever position.
  - ↑ - Forward    N - Neutral    ↓ - Reverse (Buzzer will sound)
- Release park brake and slowly press accelerator pedal to increase speed.
- All-wheel drive will automatically drive appropriate wheel(s) as required.

**TO STOP VEHICLE**

- Release accelerator pedal and push brake pedal. After stopping, firmly set park brake.
- Turn key to "OFF" position, remove key and place shift lever in neutral position when not in use.

CCI 102458101



ROTATING PARTS WARNING DECAL

OPERATING INSTRUCTIONS (ON PANEL BETWEEN SEATS OR ON OPTIONAL CONSOLE/CUP HOLDER)



HOT MANIFOLD WARNING DECAL (ON ENGINE VALVE COVER)

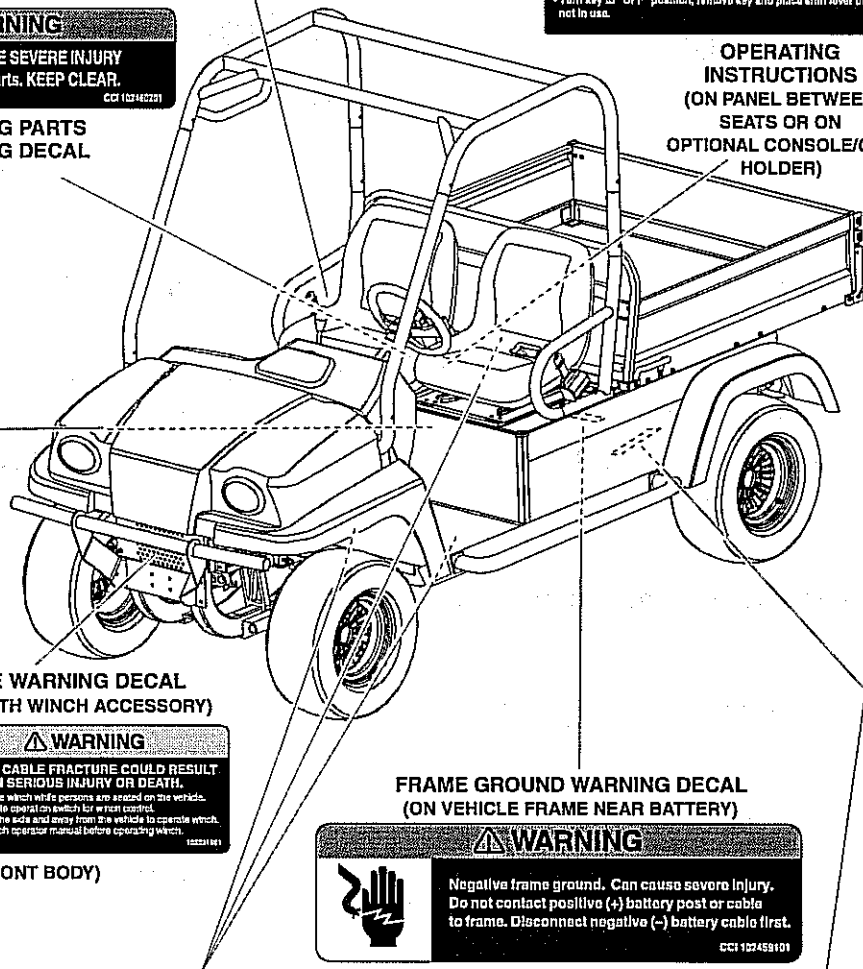

WINCH CABLE WARNING DECAL (FOR VEHICLES WITH WINCH ACCESSORY)

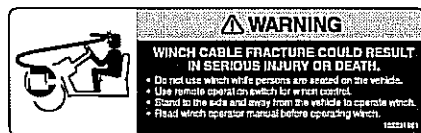

(ON FRONT BODY)

FRAME GROUND WARNING DECAL (ON VEHICLE FRAME NEAR BATTERY)

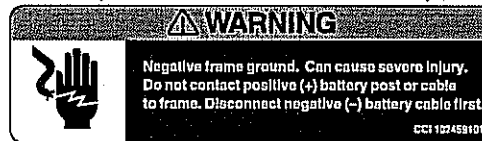

HOT SURFACE WARNING DECAL (5) (ON COOLANT PIPES, UNDERSIDE OF EACH SEAT, AND CROSSBAR BEHIND SEATS)

ROTATING PARTS AND HOT MANIFOLD DECAL (ON DRIVER-SIDE VEHICLE FRAME)



# Practice Safety

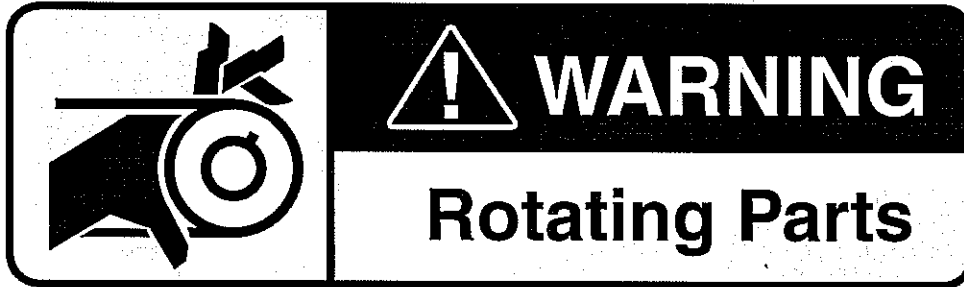

Safety signs like you see above may at first seem shocking, but their impact is mild compared with the reality of severe personal injury.

Your safety and satisfaction are of the utmost importance to Husqvarna. That is why before operating the vehicle, we urge you to review the information in this manual. Understand and become familiar with the **DANGER**, **WARNING** and **CAUTION** statements and procedures it contains, along with the safety decals that are affixed to your vehicle.

Take time to understand the language of safety. It is a language that can save your life.

## PROPOSITION 65 – STATE OF CALIFORNIA

---

### **▲ WARNING**

This product contains or emits chemicals or substances that have been determined by the state of California to cause cancer and birth defects or other reproductive harm.

## SAFETY DETAILS

### **⚠ WARNING**

- This owner's manual should be read completely before attempting to drive or service the vehicle. Failure to follow the instructions in this manual could result in property damage, severe personal injury, or death.

It is important to note that some vital statements throughout this manual and on the decals affixed to the vehicle are preceded by the words DANGER, WARNING, or CAUTION. For your protection, we recommend that you take special notice of these safety precautions. Safety precautions are essential and must be followed.

If any of the operation or warning decals on the vehicle become damaged, have been removed, or cannot be easily read, they should be replaced immediately to avoid possible property damage, personal injury, or death. Contact your Husqvarna dealer.

### **⚠ DANGER**

- A DANGER indicates an immediate hazard that will result in severe personal injury or death.

### **⚠ WARNING**

- A WARNING indicates an immediate hazard that could result in severe personal injury or death.

### **⚠ CAUTION**

- A CAUTION with the safety alert symbol indicates a hazard or unsafe practice that could result in minor personal injury.

### **CAUTION**

- A CAUTION without the safety alert symbol indicates a situation that potentially could result in property damage.

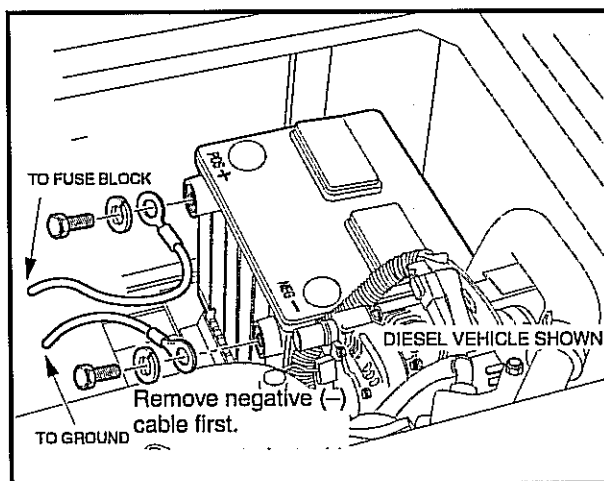

Figure 1 Battery Cable Removal

---

## GENERAL WARNINGS

---

The following safety statements must be heeded whenever the vehicle is being operated, repaired, or serviced. Safety decal identification information is also included beginning on page 4. Other specific safety statements appear throughout this manual and on the vehicle.

### **DANGER**

- **Battery – Explosive gases! Do not smoke. Keep sparks and flames away from the vehicle and service area. Ventilate when charging or operating vehicle in an enclosed area. Wear a full face shield and rubber gloves when working on or near batteries.**
- **Gasoline/Diesel – Flammable! Explosive! Do not smoke. Keep sparks and flames away from the vehicle and service area. Service only in a well-ventilated area.**
- **Do not operate engine in an enclosed area without proper ventilation. The engine produces carbon monoxide, which is an odorless, deadly poison.**
- **A Husqvarna vehicle will not provide protection from lightning, flying objects, or other storm-related hazards. If caught in a storm while driving a Husqvarna vehicle, exit the vehicle and seek shelter in accordance with applicable safety guidelines for your location.**

### **WARNING**

- **Follow the procedures exactly as stated in this manual, and heed all DANGER, WARNING, and CAUTION statements in this manual as well as those on the vehicle.**
- **Do not leave children unattended on vehicle.**
- **Children requiring a child safety seat must not ride on the vehicle. Comply with state and local laws pertaining to child safety.**
- **The driver and passenger must be restrained at all times with the safety belts provided to help prevent injury in the event of sudden braking, collision, or roll-over.**
- **No more than one person per seat at one time. Do not allow people to ride in any part of the vehicle that is not equipped with a seat and a safety belt. Do not allow a passenger to hold a child in his or her lap while the vehicle is moving.**
- **Prior to leaving the vehicle unattended or servicing the vehicle, set the park brake, place the Forward/Reverse handle in the NEUTRAL position, turn the key switch to the OFF position, and remove the key. Chock the wheels when servicing the vehicle.**
- **Improper use of the vehicle or failure to properly maintain it could result in decreased vehicle performance, severe personal injury, or death.**
- **Any modification or change to the vehicle that affects the stability or handling of the vehicle, or increases maximum vehicle speed beyond factory specifications, could result in severe personal injury or death.**
- **Check the vehicle for proper location of all vehicle safety and operation decals and make sure they are in place and are easy to read.**
- **For vehicles with cargo beds, remove all cargo before raising the bed or servicing the vehicle. If the vehicle is equipped with a prop rod, ensure that it is securely engaged while bed is raised. Do not close bed until all persons are clear of cargo bed area. Keep hands clear of all crush areas. Do not drop cargo bed; lower gently and keep entire body clear. Failure to heed this warning could result in severe personal injury or death.**

WARNING CONTINUED ON NEXT PAGE...

**⚠ WARNING**

- Only trained technicians should service or repair the vehicle. Anyone doing even simple repairs or service should have knowledge and experience in electrical and mechanical repair. The appropriate instructions must be used when performing maintenance, service, or accessory installation.
- To avoid unintentionally starting the vehicle:
  - Disconnect battery cables, negative (-) cable first (Figure 1).
  - Gasoline vehicles only: Disconnect the spark plug wires from the spark plugs.
- Frame ground – Do not allow tools or other metal objects to contact frame when disconnecting battery cables or other electrical wiring. Do not allow a positive wire to touch the vehicle frame, engine, or any other metal component.
- Wear safety glasses or approved eye protection when servicing the vehicle. Wear a full face shield and rubber gloves when working on or near batteries.
- Do not wear loose clothing or jewelry such as rings, watches, chains, etc., when servicing the vehicle.
- Use insulated tools when working near batteries or electrical connections. Use extreme caution to avoid shorting of components or wiring.

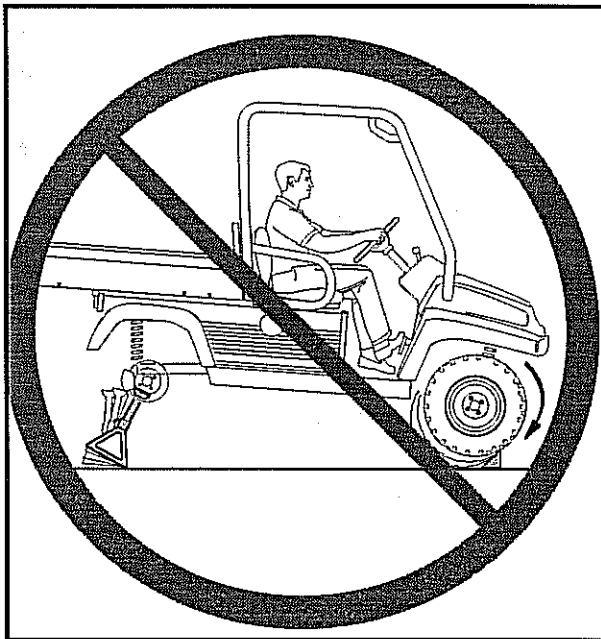

Figure 2 All-wheel Drive Warning

- When servicing the vehicle with part of the vehicle on jack stands, do not operate the engine with the Forward/Reverse handle in either the FORWARD or REVERSE position. The all-wheel drive system will engage any wheel(s), front or rear, with traction.

## MODEL IDENTIFICATION

The serial number of each vehicle is printed on a bar code decal mounted on the frame directly above the accelerator pedal (Example: DH0501-123456) (Figure 3). There is also a second serial number decal mounted on the rear body frame behind the fuel tank. The fuel tank must be removed to view this decal. See following NOTE.

**NOTE:** Have the vehicle serial number available when ordering parts or making inquiries.

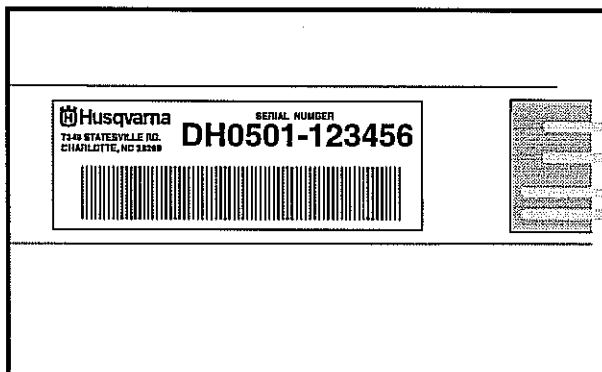

Figure 3 Serial Number

## CONTROLS AND INDICATORS

See General Warnings on page 10.

### **▲ WARNING**

- Before allowing anyone to drive the vehicle, make sure the driver is familiar with all controls and operating procedures.
- Do not tamper with the governor on the gasoline vehicle or the high idle speed setting on the diesel vehicle. Doing so will void the warranty, as well as damage the engine and other components, and could result in property damage, personal injury, or death due to unsafe speeds.
- Do not shift the Forward/Reverse handle while the vehicle is in motion.
- Engine must be at idle before shifting the Forward/Reverse handle. Failure to do so may result in injury to inattentive passengers and (or) damage to the vehicle.
- To avoid unintentionally starting or rolling the vehicle, set the park brake, place the Forward/Reverse handle in the NEUTRAL position, turn the key switch to the OFF position, and remove the key when leaving the vehicle.

### KEY SWITCH – GASOLINE VEHICLES

The key switch (2) is mounted on the instrument panel to the right of the steering column (Figure 4). It has three positions: OFF, ON, and START. To start the vehicle, place the Forward/Reverse handle in the NEUTRAL position and turn the key all the way to the START position, activating the choke (3) as necessary, and hold until the engine starts. If the engine does not start after 10-15 seconds, release the key and repeat the procedure. Once the engine starts, release the key and it will return to the ON position. The engine will idle in

neutral. The engine will continue to idle until the key is turned to the OFF position. See following **WARNING**, **CAUTION** and **NOTE**.

## KEY SWITCH – DIESEL VEHICLES

The key switch (2) is mounted on the instrument panel to the right of the steering column (**Figure 5**). It has four positions: PREHEAT, OFF, ON, and START. To preheat glow plugs in cold weather, turn the key to the PREHEAT position and hold for 10-15 seconds. Then turn the key all the way to the START position and hold until the engine starts. If the engine does not start after 10-15 seconds, return the key to the OFF position and repeat the procedure. Once the engine starts, release the key and it will return to the ON position. The engine will idle in neutral. The engine will continue to idle until the key is turned to the OFF position. See following **WARNING**, **CAUTION** and **NOTE**.

Turn the key to PREHEAT position if the temperature falls below 23 °F (-5 °C). Do not hold the key in the PREHEAT position longer than 20 seconds.

### **▲ WARNING**

- Moving parts! Keep clear of the engine compartment while the engine is running.

### **CAUTION**

- Do not shift the Forward/Reverse handle while the accelerator pedal is pressed. Shift the handle only when the vehicle is at a complete stop and the engine is at idle. Failure to heed this caution could result in damage to the transmission.

**NOTE:** The key can be removed only when the key switch is in the OFF position.

## FORWARD/REVERSE CONTROL

The Forward/Reverse handle (1) is located on right-hand side of the instrument panel. The handle has three distinct positions: FORWARD (A), NEUTRAL (B), and REVERSE (C) (**Figure 4** or **Figure 5**). Push the handle up to operate the vehicle in the forward direction, or pull the handle down to operate the vehicle in reverse. The engine can be started only when the handle is in the NEUTRAL (middle) position. The engine must be at idle before shifting the Forward/Reverse handle. See **WARNING** and **CAUTION** beginning on page 13.

Husqvarna vehicles operate at a reduced speed in reverse. The reverse buzzer will sound as a warning when the Forward/Reverse handle is in the REVERSE position.

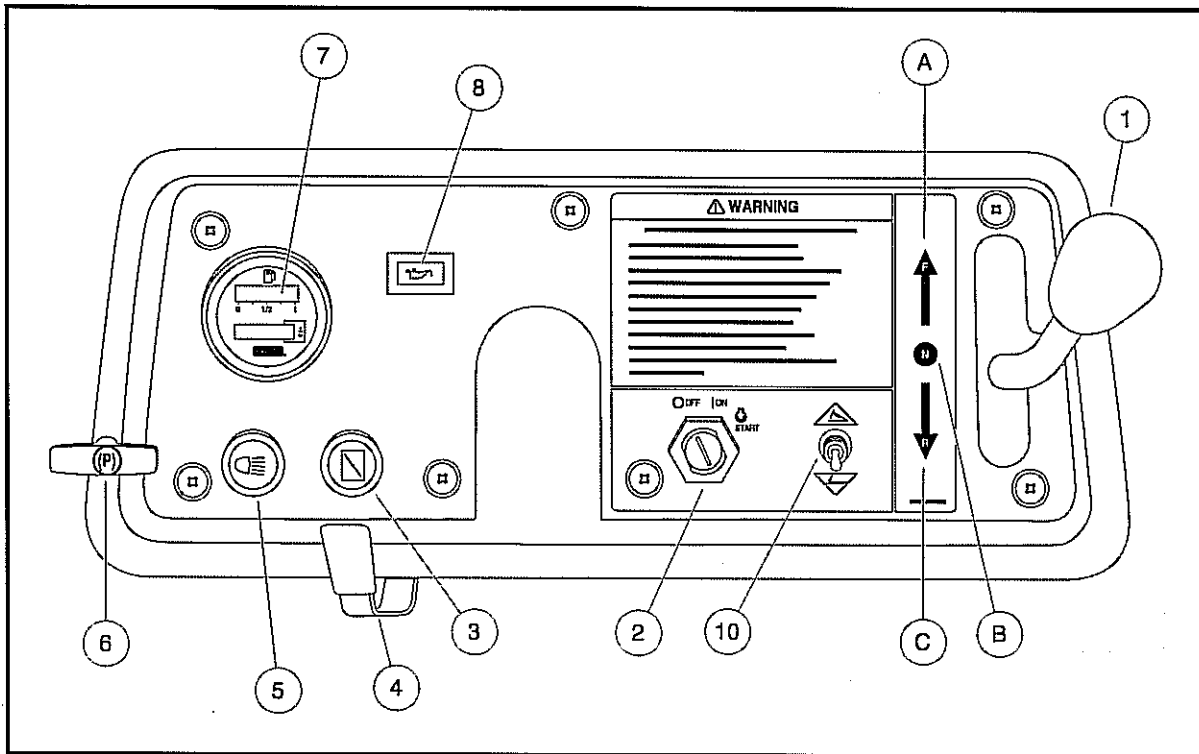

Figure 4 Instrument Panel – Gasoline Vehicles

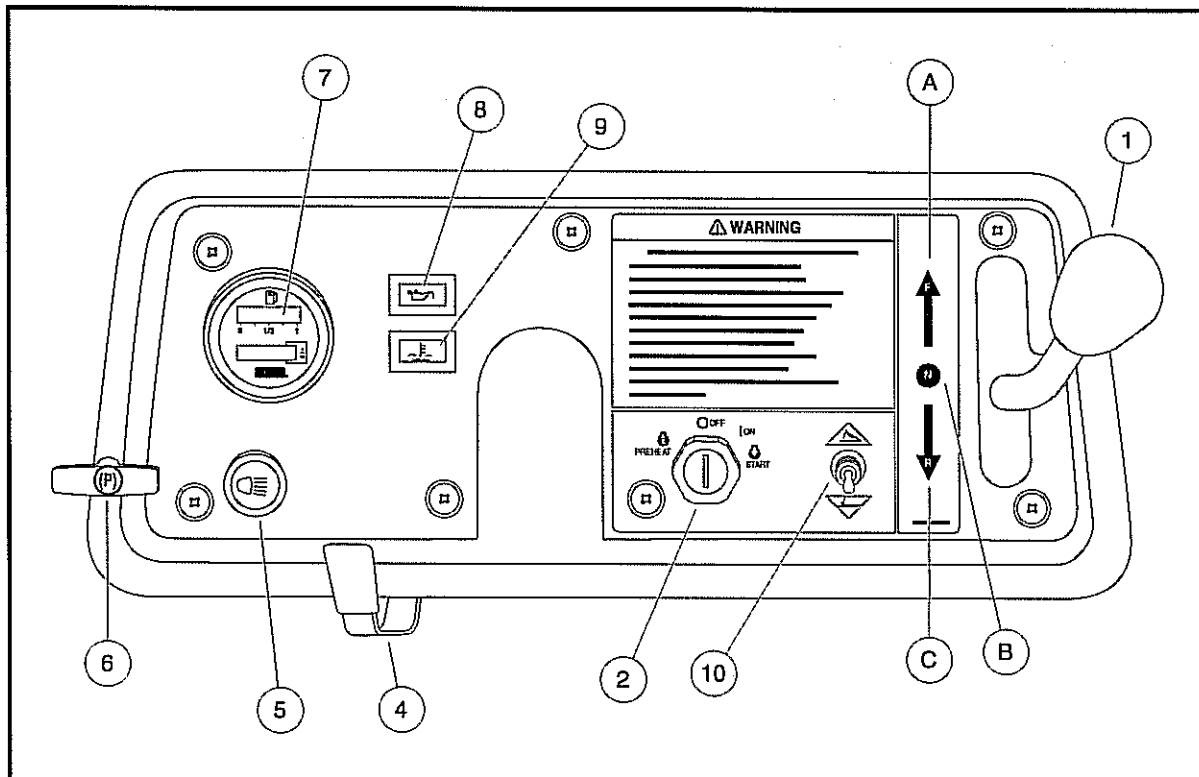

Figure 5 Instrument Panel – Diesel Vehicles

## ACCELERATOR PEDAL

The accelerator pedal (1) is the pedal on the right (**Figure 6**).

With the engine running and the Forward/Reverse handle in the FORWARD or REVERSE position, vehicle speed will increase as the accelerator pedal is pressed. When the accelerator pedal is released, it will return to the original position and the engine will idle. **See WARNING and CAUTION on page 13.**

## BRAKE PEDAL

The brake pedal (2) is located to the immediate left of the accelerator pedal (**Figure 6**). To slow or stop the vehicle, press the brake pedal.

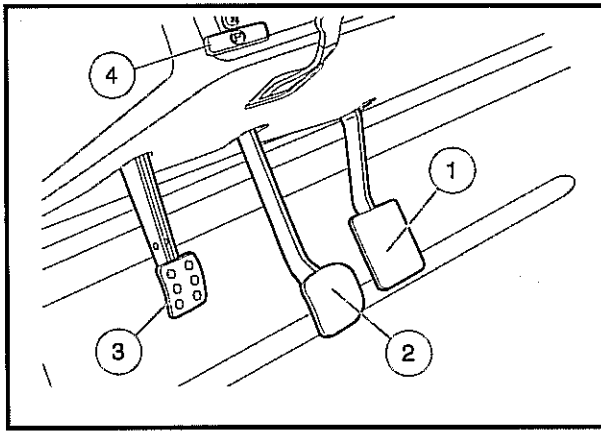

Figure 6 Pedals

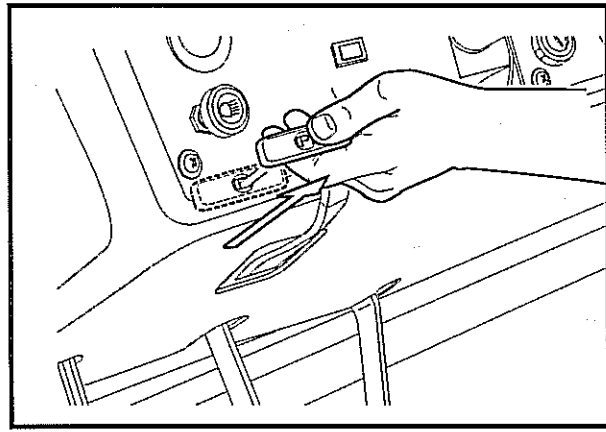

Figure 7 Park Brake Release

## PARK BRAKE

The park brake pedal (3) is located to the left of the brake pedal (**Figure 6**). To engage the park brake, first apply pressure to the brake pedal, then firmly press the park brake pedal until it latches into place. To disengage, pull the park brake release handle (**Figure 7**). **See following WARNING.**

### **⚠ WARNING**

- The park brake has multiple locking positions and should be firmly locked to prevent the vehicle from rolling.

## LOW OIL WARNING LIGHT

The low oil warning light (8) is located on the instrument panel just to the left of the steering column (**Figure 4 or Figure 5**). If the warning light comes on, oil should be checked and added to the engine as necessary before continuing to use the vehicle. The vehicle should never be driven when the low oil warning light remains on. If the warning light goes on and off, the vehicle may be driven, but oil should be added at the first opportunity. If the oil level is correct and the warning light stays on, have a trained technician check the vehicle. **See following CAUTION.**

### **CAUTION**

- Failure to add oil immediately when the low oil warning light stays on may result in permanent engine damage.

## ELECTRIC BED LIFT

The electric bed lift switch (10) is located on the dash panel, to the right of the key switch (2) (Figures 4 and 5, Page 14). The bed lift can be operated while the key switch is in either the OFF or ON position.

To raise the bed, push and hold the toggle switch (10) in the upper position. Release the switch to stop the lifting operation. To lower the bed, press and hold the switch in the lower position. The bed lift will click loudly to signal the bed is in the rest position. **See following WARNING.**

### **▲ WARNING**

- Keep clear of moving parts when bed is in the raised position and the engine is running
- For vehicles with cargo beds, remove all cargo before raising the bed or servicing the vehicle. If the vehicle is equipped with a prop rod, ensure that it is securely engaged. Do not close bed until all persons are clear of cargo bed area. Keep hands clear of all crush areas. Do not drop cargo bed; lower gently and keep entire body clear. Failure to heed this warning could result in severe personal injury or death.

## FUEL GAUGE/HOUR METER

The fuel gauge and hour meter (7) are housed together at the left side of the instrument panel (Figure 4 or Figure 5, Page 14). The fuel gauge operates when the key switch is in the ON position, and allows the operator to monitor the fuel level in the vehicle. The hour meter operates only when the engine is running, and should be used by the trained technician to track vehicle usage and determine when periodic service procedures are required. **See Periodic Service Schedule on page 29.**

## HEADLIGHT CONTROL

The headlight control (5) is located on the left side of the instrument panel below the fuel gauge/hour meter (Figure 4 or Figure 5, Page 14). Pull the headlight control knob out to turn headlights on and push the knob in to turn headlights off.

***NOTE:** Using the headlights for extended periods of time without the engine running, or with the engine idling, will discharge the battery.*

## STEERING ADJUSTMENT LOCK

The steering wheel on the HUV4420 and HUV4420-D vehicles is adjustable. To adjust the steering wheel, press down on the steering adjustment lock lever (4), then move the steering wheel to the desired position (Figure 4 or Figure 5, Page 14). While holding the steering wheel in the desired position, pull up on the steering adjustment lock lever to firmly lock the steering column in position.

### **▲ WARNING**

- Ensure that the steering wheel lock is fully engaged prior to operating the vehicle.

## CHOKE

### Gasoline Vehicles Only

The choke (3) is located on the instrument panel to the left of the steering column. If the vehicle is hard to start in cool or cold temperatures, activate choke: Pull the choke handle out to activate. Release the handle when the engine begins to run smoothly (Figure 4, Page 14).

## HIGH-TEMPERATURE WARNING LIGHT

### Diesel Vehicles Only

The high-temperature warning light (9) is located on the instrument panel below the low oil warning light (8) (Figure 5, Page 14). The diesel engine is liquid-cooled; if the engine coolant has exceeded its normal safe operating temperature, the warning lamp will illuminate. If the warning light comes on, stop the vehicle and allow it to idle for approximately five minutes before stopping the engine. Contact a Husqvarna dealer/distributor or a trained technician.

### **▲ WARNING**

- Allow the engine to cool before servicing the engine coolant system. Engine coolant can cause severe burns.

## ROLL-OVER PROTECTIVE STRUCTURE (ROPS) AND SAFETY BELTS

---

The HUV4420 and HUV4420-D vehicles are equipped with a certified Roll-over Protective Structure (ROPS) and safety belts for each occupant. See following WARNING.

### **▲ WARNING**

- The ROPS must be properly installed before operating the vehicle.

Husqvarna strongly urges that the vehicle's occupants be properly restrained at all times with the safety belts provided.

**Pregnant woman:** Consult your doctor for specific recommendations. The safety belt should be worn securely and as low as possible over the hips and not on the waist.

**Injured person:** Depending on the injury, first check with your doctor for specific recommendations.

To secure safety belt, sit up straight and well back in the seat. Pull safety belt out of the retractor and insert the tab into the buckle. A click will be heard when the tab locks into the buckle. Position the lap belt as low as possible on the hips – not on the waist. (Figure 8, Page 18).

The retractor will lock the belt during a sudden stop. It also may lock if the person leans forward too quickly. A slow, easy motion will allow the belt to extend, and the person can move around freely. If the safety belt cannot be pulled out of the retractor, firmly pull the belt and release it. It should then pull smoothly out of the retractor.

To release the safety belt, press the buckle release button (1) and allow the belt to retract. If the belt does not retract smoothly, pull it out and check for kinks or twists. Then make sure it remains free of twists as it retracts (Figure 9, Page 18).

### **▲ WARNING**

- Do not modify the ROPS or operate the vehicle with the ROPS removed. Doing so will void the certification and could result in property damage, personal injury, or death.
- Do not operate the vehicle if the ROPS is damaged. If the ROPS is damaged, replace the structure. Do not attempt repair.
- The driver and passenger must be restrained at all times with the safety belts provided to help prevent injury in the event of sudden braking, collision, or roll-over.
- In the event of a roll-over, do not attempt to jump or otherwise exit the vehicle. Remain seated with safety belt fastened and with arms and legs inside the vehicle.

WARNING CONTINUED ON NEXT PAGE...

## **⚠ WARNING**

- After inserting the tab, make sure the tab and buckle are locked and that the belt is not twisted.
- Loose fitting safety belts could increase the chance of injury due to sliding under the belt if sudden braking should occur. Keep the safety belt snug and positioned as low on the hip bone as possible.
- Use a single safety belt for one person at a time. Do not use a single safety belt for two or more people – this includes children.
- No more than one person per seat at one time. Do not allow people to ride in any part of the vehicle that is not equipped with a seat and a safety belt. Do not allow a passenger to hold a child in his or her lap while the vehicle is moving.
- The Husqvarna vehicle is not designed to meet child seat compatibility requirements. Children requiring a child safety seat must not ride on the vehicle. Comply with state and local laws pertaining to child safety.

## **⚠ CAUTION**

- Be careful not to damage the safety belt webbing or hardware.
- Inspect the safety belt system periodically. Check for cuts, fraying, and loose parts. Damaged parts should be replaced immediately. Do not disassemble or modify the system.
- Keep safety belts clean and dry. If cleaning is necessary, use a mild soap and lukewarm water solution. Do not use bleach, dye or abrasive cleaners as they may severely weaken the safety belts.
- Do not insert coins, clip, etc. in the buckle as this may prevent the tab from locking into the buckle properly.
- If the safety belt does not function normally, contact your Husqvarna dealer/distributor or trained technician immediately. Do not occupy the seat until the safety belt is repaired.

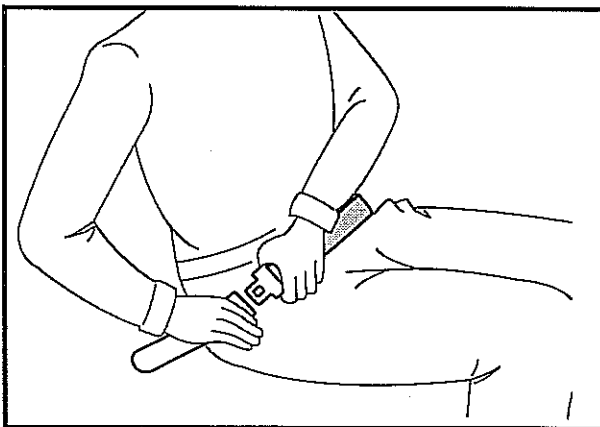

Figure 8 Secure Safety Belt

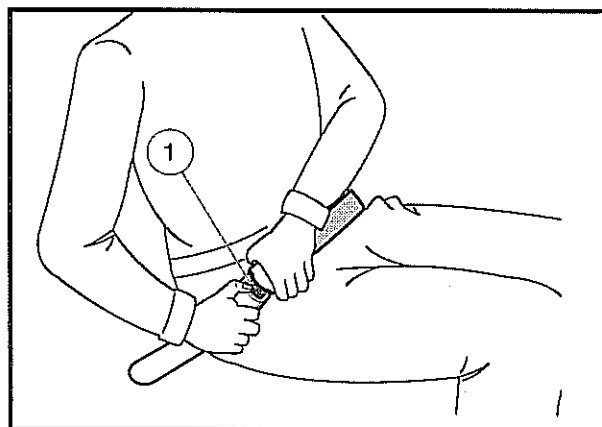

Figure 9 Release Safety Belt

## SEAT LATCH AND ADJUSTMENT

The seats are hinged to allow easy access to the engine compartment. A latch at the rear of each seat bottom keeps the seat from moving on its hinges while the vehicle is in operation. To disengage the latch, grasp the seat back and pull firmly in a forward/upward direction until the latch releases. To engage the seat latch, push down firmly on the seat back until the seat locks into place. **See following WARNING.**

### **⚠ WARNING**

- **Make sure seat hinges and latch are securely engaged before operating vehicle.**

The driver-side bucket seat is adjustable and can be moved forward or backward to accommodate the driver. To adjust seat, push lever located under the driver seat to the left (towards outside of the vehicle). Position seat and return lever to its original position. **See following WARNING.**

### **⚠ WARNING**

- **Do not adjust driver-side seat while vehicle is in motion.**

To adjust the passenger-side seat:

1. Remove the seat from the vehicle.
2. Remove the four bolts and washers from the bottom of the seat mounting plate.
3. Align the mounting plate holes with holes in the seat to achieve the desired seat position.
4. Install washers and bolts and tighten to 96 in-lb (10.8 N·m).
5. Install seat in the vehicle. **See preceding WARNING "Make sure seat hinges and latch..."**.

## PRE-OPERATION AND DAILY SAFETY CHECKLIST

Each Husqvarna vehicle has been thoroughly inspected and adjusted at the factory; however, upon receiving your new vehicle(s), you should become familiar with its controls, indicators, and operation. Carefully inspect each vehicle to ensure that it is in proper working condition before accepting delivery.

Use the following checklist as a guide to inspect the vehicle. This checklist should be used daily to ensure that the vehicle is in proper working condition and in conjunction with the Periodic Service Schedule on page 29. Any problems should be corrected by a Husqvarna dealer/distributor or a trained technician.

- **General:** All the parts should be in place and properly installed. Be sure that all nuts, bolts, and screws are tight. Check hose clamps for tight fit.
- **Safety and information decals:** Check to ensure that all safety and information decals are in place. **See pages 4 through 7.**
- **Roll-over Protective Structure (ROPS):** Check to ensure the ROPS is not damaged and all hardware is secure. **See Roll-over Protective Structure (ROPS) and Safety Belts on page 17.**
- **Safety belts:** Visually inspect for cuts, fraying, and loose parts. **See Roll-over Protective Structure (ROPS) and Safety Belts on page 17.**
- **Tires:** Check for proper tire pressure. Visually inspect tires for wear, damage, and proper inflation on a daily basis. **See Vehicle Specifications on page 47.**
- **Battery:** Check electrolyte to ensure it is at the proper level (**Figure 36, Page 44**). Check battery posts. Wires should be tight and free of corrosion and battery should be fully charged.

- **Engine:** Check for proper engine oil and coolant levels (diesel vehicles) and leaks. **See Engine Oil on page 34 and Engine Coolant – Diesel Vehicles on page 40.** Check air filter and replace if necessary.
- **Fuel:** Check fuel level. **See Fueling Instructions on page 41.** Check fuel tank, lines, fuel cap, pump, fuel filters, and carburetor (gasoline vehicles) for fuel leakage. Drain water from the fuel filter (diesel vehicle). **See Draining Water from Fuel Filter on page 42.**
- **Exhaust system:** Check for leaks.
- **Hydraulic brakes:** Check fluid level. **See Brake Fluid Reservoir on page 34.**

## PERFORMANCE INSPECTION

After you have familiarized yourself with the vehicle controls and have read and understood the driving instructions, take the vehicle for a test drive.

Use the following checklist as a guide to inspect the vehicle and check daily for proper operation. Any problems should be corrected by a Husqvarna dealer/distributor or a trained technician.

- **Forward/Reverse shifter:** Check for proper operation. **See Controls and Indicators on page 12.**
- **Brakes:** Be sure the brakes function properly. When brake pedal is fully pressed under moderate pressure, the vehicle should come to a smooth, straight stop. If the vehicle swerves or fails to stop, have the brake system checked and adjusted as required. When brake pedal is fully pressed under heavy pressure, pedal should feel firm and the back of the pedal should be a minimum of 1.25 inches (3.2 cm) from floorboard. Brake adjustment must be maintained so the brake pedal cannot be pressed to the floorboard under any circumstance.
- **Park brake:** When latched, the park brake should lock the wheels and hold the vehicle stationary (on an incline of 20% or less).
- **Reverse buzzer:** The reverse buzzer should sound as a warning when the Forward/Reverse handle is in the REVERSE position.
- **Steering:** The vehicle should be easy to steer and should not have any play in the steering wheel. Be sure the steering wheel adjustment lever is locked into position.
- **Accelerator:** After starting the engine with the key switch and placing the Forward/Reverse handle in the FORWARD position, the vehicle should accelerate smoothly to full speed as the accelerator pedal is pressed. When the pedal is released it should return to the original position and the engine should idle. Husqvarna vehicles operate at reduced speed in reverse.
- **Governor:** Check maximum vehicle speed. It should operate in forward at 25 mph (40 km/h) on a level surface.
- **General:** Listen for any unusual noises such as squeaks or rattles. Check the vehicle's ride and performance. Have a Husqvarna dealer or a trained technician investigate anything unusual.

## DRIVING INSTRUCTIONS

---

### **WARNING**

- **Only licensed drivers should be allowed to drive the vehicle.**
- **Before allowing anyone to drive the vehicle, make sure the driver is familiar with all controls and operating procedures.**

WARNING CONTINUED ON NEXT PAGE...

**⚠ WARNING**

- No one under the age of 16 years should be allowed to drive the vehicle.
- No more than one person per bucket seat at one time, or two persons per bench seat.
- Do not allow riders in the cargo bed.
- For night use, the vehicle must be equipped with headlights, taillights, and reflectors.
- The vehicle is not specially equipped for handicapped persons:
  - Be sure all passengers are capable of securing themselves in a moving Husqvarna vehicle before allowing them to ride in one.
  - Be sure all persons can properly operate the vehicle prior to allowing them to drive the vehicle.
- Stop the vehicle before shifting the Forward/Reverse handle. Engine must be at idle before shifting the Forward/Reverse handle. Failure to do so may result in injury to inattentive passengers and (or) damage to the vehicle.
- To help avoid being struck, do not stand in front of or behind the vehicle.
- Do not leave children unattended on vehicle.
- Children requiring a child safety seat must not ride on the vehicle. Comply with state and local laws pertaining to child safety.
- Operate the vehicle from the driver seat only.
- To help prevent falls from the vehicle, remain seated with safety belt fastened and hold on to hand holds at all times. Driver should keep both hands on the steering wheel when the vehicle is in motion.
- To help prevent the possibility of serious injury, keep entire body inside the vehicle.
- To help prevent overturning the vehicle, drive slowly in turns.
- To help prevent overturning the vehicle, drive slowly straight up and down slopes. Avoid driving the vehicle on slopes exceeding 20% incline.
- Avoid stopping a loaded vehicle on a hill. If a loaded vehicle must be stopped on a hill, avoid sudden starts or rolling backwards and stopping suddenly. Failure to heed this warning could result in overturning the vehicle.
- To help avoid possible injury to inattentive passengers and (or) damage to the vehicle, avoid sudden starts, sudden stops, and abrupt turns.
- To help avoid the possibility of losing control of or overturning the vehicle, reduce speed for adverse driving conditions such as wet grass or rough terrain.
- Do not use the vehicle on public roads. It is neither designed nor intended for street use and should not be licensed for use on public roads.
- The vehicle should be driven in only specified areas by trained drivers.
- Do not drive while under the influence of alcohol, drugs, or medications.
- Use brakes to reduce speed when coasting downhill.
- Never attempt jumps.
- Keep away from drop-offs, steep slopes, and unstable surfaces.
- Avoid extremely hard braking in reverse.

No one should drive the vehicle without first being instructed in the proper operation and use of vehicle controls. An experienced operator should accompany each first-time driver on a test drive before allowing the driver to operate the vehicle alone.

To ensure safe operation of the vehicle, follow exactly and in order, all of the following procedures. Read and understand all instructions prior to driving the vehicle.

## STARTING THE VEHICLE

1. Read safety warnings on the instrument panel and vehicle loading information located above pedals.
2. Be sure load, if any, is secure.
3. Study and understand controls.
4. Be sure all passengers are seated with safety belt fastened and holding on to hand holds. Driver should have both hands on the steering wheel.
5. Make sure wheels are turned in desired direction and nothing is in your path.
6. Make sure the Forward/Reverse handle is in the NEUTRAL position.
7. Press and hold the brake pedal.
8. To start the vehicle:
  - 8.1. **Gasoline vehicles:** Turn the key all the way to the START position and hold, activating the choke as necessary, until the engine starts. If the engine does not start after 10-15 seconds, release the key and repeat the procedure. Once the engine starts, release the key and it will return to the ON position. The engine will idle in neutral.
  - 8.2. **Diesel vehicles:** To preheat glow plugs in cold weather, turn the key to the PREHEAT position and hold for 10-15 seconds. Then turn the key all the way to the START position and hold until the engine starts. If the engine does not start after 10-15 seconds, return the key to the START position and repeat the procedure. Once the engine starts, release the key and it will return to the ON position. The engine will idle in neutral.
9. Release the park brake.
10. While keeping the brake pedal engaged, select direction of travel by placing shift handle in desired position (**Figure 4, Page 14** or **Figure 5, Page 14**). Engine must be at idle before moving shift handle. A buzzer will sound as a warning when the Forward/Reverse handle is in the REVERSE position.
11. Release the brake pedal completely, and then slowly press the accelerator pedal. As the accelerator pedal is pressed, the vehicle will begin to move, and speed will increase until full speed is reached. All-wheel drive will automatically drive appropriate wheel(s) as required. **See following WARNING.**

### **WARNING**

- Operator must control vehicle speed when going downhill.
- Never shift the vehicle out of the FORWARD position while going downhill. If you do, you will not be able to shift into the REVERSE position or back into the FORWARD position until stopped.
- Press the brake pedal as necessary and press the accelerator pedal partially when descending a hill. With the accelerator pedal partially pressed, the governor will cause the engine to assist the brakes in controlling downhill speed.

## ALL-WHEEL DRIVE (AWD) OPERATION

The HUV4420 and HUV4420-D vehicles feature an all-wheel drive (AWD) system. The AWD system automatically directs power to the wheel, or wheels, that have the most traction, providing optimum traction at all times. For example, if all wheels except the rear passenger-side wheel lose traction, then power will be directed to the rear passenger-side wheel. The all-wheel drive vehicle can adapt traction for a wide variety of driving surfaces and conditions. **See following WARNING.**

---

**▲ WARNING**

- When servicing the vehicle with part of the vehicle on jack stands, do not operate the engine with the Forward/Reverse handle in either the FORWARD or REVERSE position. The all-wheel drive system will engage any wheel(s), front or rear, with traction. See Figure 2 on page 11.

Under most circumstances the driver will not need to do anything to engage the AWD system; however, the front differential may become locked (rotate at the same speed regardless of the terrain) under certain conditions. If the front differential becomes locked, drive slowly in reverse for at least 10 feet (3 meters), then brake gently. See following **WARNING**.

**▲ WARNING**

- Reduced steering control can occur if the front differential becomes locked. To help prevent this condition, avoid extremely hard braking in reverse.

**STOPPING THE VEHICLE**

To stop the vehicle, release the accelerator pedal and press the brake pedal until the vehicle comes to a complete stop. See following **WARNING** and **CAUTION**.

**▲ WARNING**

- Driving through water may affect the brakes. After driving through water, check effectiveness of the brakes by gently pressing the brake pedal. If the vehicle does not slow down at the normal rate, continue to press the brake pedal until the brakes dry out and normal performance returns.

**▲ CAUTION**

- When stopped on a hill, use the brake pedal to hold your position. Do not use the accelerator pedal to hold position.

**PARKING AND LEAVING THE VEHICLE**

1. After stopping the vehicle, firmly set park brake. Make sure it is fully engaged. This will prevent the vehicle from rolling.
2. Turn the key switch to the OFF position, remove the key, and place the Forward/Reverse handle in the NEUTRAL position.

**Gasoline vehicles only:** Turn the fuel shut-off valve to the closed (OFF) position when the vehicle is not in use (Figure 10, Page 26). See also Figure 32 and Figure 33 on page 42.

---

**FRONT SHOCK ABSORBERS**

The vehicle arrives from the factory with the front coil-over shock absorbers pre-adjusted for optimum vehicle performance. We do not recommend adjusting the shock absorbers unless the vehicle will be equipped with a cab enclosure or snow plow. In that event, please refer to the cab installation instructions for the shock absorber adjustment procedure.

---

## LOADING AND UNLOADING

---

### **▲ WARNING**

- Firmly engage park brake before loading vehicle.
- Do not allow riders in the cargo bed.
- Reduce vehicle load and speed when driving up or down slopes or on uneven terrain.
- Do not exceed rated vehicle capacity. Rated capacity is for level surfaces only.
- Overloading can affect vehicle handling or cause component failure, resulting in loss of control of vehicle and possible severe personal injury or death.
- Do not load tailgate. The tailgate should be in the upright position and latched securely while the vehicle is in motion.
- To help avoid shifting vehicle load and possibly overturning the vehicle, avoid sudden starts, sudden stops and abrupt turns. Make sure cargo is well secured.
- Avoid top-heavy loads. The center of gravity of load should never exceed 15 inches (38 cm) above the bottom of the cargo bed.
- The cargo's center of gravity may affect handling, steering, and braking of the vehicle. When the vehicle is loaded, reduce speed and drive slowly in turns.
- Unload cargo bed before raising vehicle with a lift, hoist, or jack.
- Avoid stopping on a hill when loaded. If you must stop on a hill, avoid sudden starts, or rolling backwards and stopping suddenly. Failure to heed this warning may cause vehicle to overturn, possibly resulting in severe personal injury.
- Reduce speed and avoid sudden stops when backing up. Failure to do so may cause the vehicle to overturn or flip over backwards.
- Maximum cargo load must be reduced by the weight of optional equipment.

Center and secure cargo as far forward as possible in the cargo bed. Do not overload the vehicle. See the following chart for vehicle capacities.

	STANDARD VEHICLES	HIGH CAPACITY OPTION VEHICLES
Maximum payload capacity (cargo bed load plus gross trailer weight)	800 lb. (363 kg)	1050 lb. (476 kg)
Maximum passenger capacity (operator and passenger)	400 lb. (181 kg)	400 lb. (181 kg)
Maximum gross vehicle weight limit (fully loaded vehicle, including accessories)	2750 lb. (1247 kg)	3012 lb. (1366 kg)
Trailer tongue weight	150 lb. force (667 N)	150 lb. force (667 N)

Maximum payload capacity must be reduced accordingly when any option or accessory is installed on the vehicle. See following NOTE.

**NOTE:** A standard vehicle with a cab accessory weighing 235 lb. (107 kg) must reduce its maximum payload capacity by 235 lb. (107 kg) to 565 lb. (256 kg).

---

## TOWING WITH THE VEHICLE

---

### **▲ WARNING**

- Do not tow a vehicle or trailer on public streets or highways.
- Normal vehicle operating speed should be reduced when towing.
- Extreme caution should be used when towing.
- Do not allow riders in the vehicle or trailer being towed.
- Avoid sudden starts, sudden stops, and tight turns when towing.
- Avoid stopping on a hill when towing. If you must stop on a hill, avoid sudden starts, or rolling backwards and stopping suddenly. Failure to heed this warning may cause vehicle to overturn, possibly resulting in severe personal injury.

Towing another Husqvarna vehicle or a trailer can have adverse effects on vehicle handling. Be especially cautious when towing other equipment with a Husqvarna vehicle. See the preceding chart for vehicle capacities.

Parking the vehicle with a trailer on a hill should be avoided. If you must park on a hill, apply brakes and have someone chock tires of trailer. Brakes should be released to allow chocks to absorb load of trailer. After tires have been chocked, engage park brake.

---

## TRANSPORTING ON A TRAILER

---

### **▲ WARNING**

- Gasoline vehicles only: Turn fuel shut-off valve to the closed (OFF) position (Figure 10).
- Do not allow riders in the trailer being towed.
- Avoid sudden starts, sudden stops, and tight turns when towing.
- Avoid stopping on a hill when towing. If you must stop on a hill, avoid sudden starts, or rolling backwards and stopping suddenly. Failure to heed this warning could cause the vehicle to overturn, possibly resulting in severe personal injury.
- Reduce normal driving speed when transporting a vehicle on a trailer.
- For use on public roads, the trailer must meet all federal, state, and local requirements such as taillights, brake lights, etc.
- Never tow a Husqvarna vehicle behind a passenger vehicle or truck on a public road unless it is on an approved trailer.
- The vehicle to be transported should be tied securely to the trailer, with the Forward/Reverse handle in the NEUTRAL position, the key switch in the OFF position, and the park brake firmly engaged.
- Because of the added length of the trailer, use caution when making turns.
- Do not transport the vehicle on a trailer with a load in the vehicle cargo bed.
- Remove the vehicle windshield and secure seats before transporting on a trailer.

If the vehicle must be transported over long distances or on public highways, it should be transported on an approved trailer that has an approved load rating of 2000 lb. (908 kg) per vehicle being transported.

**NOTE:** A two-car trailer should be rated at 2 x 2000 lb. = 4000 lb. (2 x 908 kg = 1816 kg).

---

## STORAGE

---

See General Warnings on page 10.

### **⚠ DANGER**

- Do not attempt to drain fuel when the engine is hot or while it is running.
- Clean up any spilled fuel before operating the vehicle.
- Store fuel in an approved fuel container only. Store in a well-ventilated area away from sparks, open flames, heaters, or heat sources.
- Keep fuel out of the reach of children.
- Do not siphon fuel from the vehicle.

### **⚠ WARNING**

- Turn the key switch to the OFF position, remove the key, and leave the Forward/Reverse handle in the NEUTRAL position during storage. This is to prevent unintentionally starting the vehicle or a fire hazard.
- Gasoline vehicles only: Turn fuel shut-off valve to the closed (OFF) position (Figure 10, Page 26).
- Do not attempt to charge frozen batteries or batteries with bulged cases. Discard the battery. Frozen batteries can explode.

### **⚠ CAUTION**

- Batteries in a low state of charge will freeze at low temperatures.

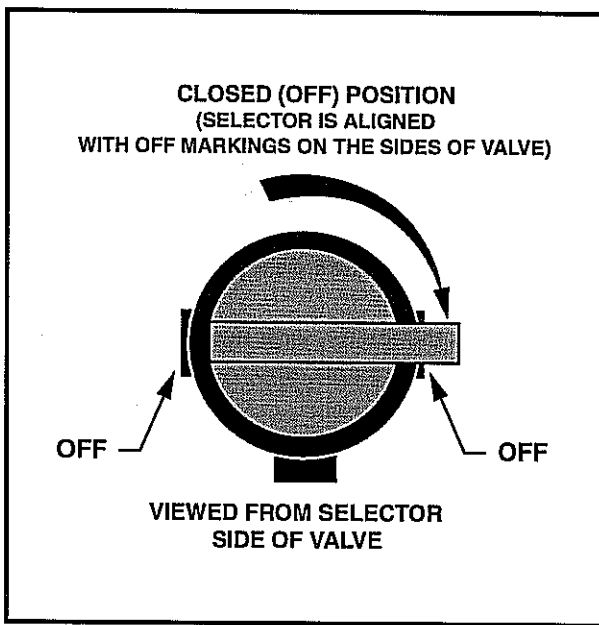

Figure 10 Fuel Shut-off Valve – Closed Position

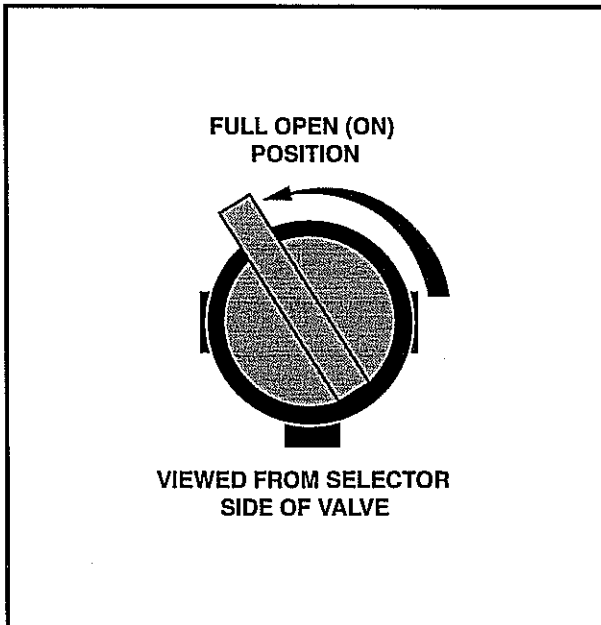

Figure 11 Fuel Shut-off Valve – Open Position

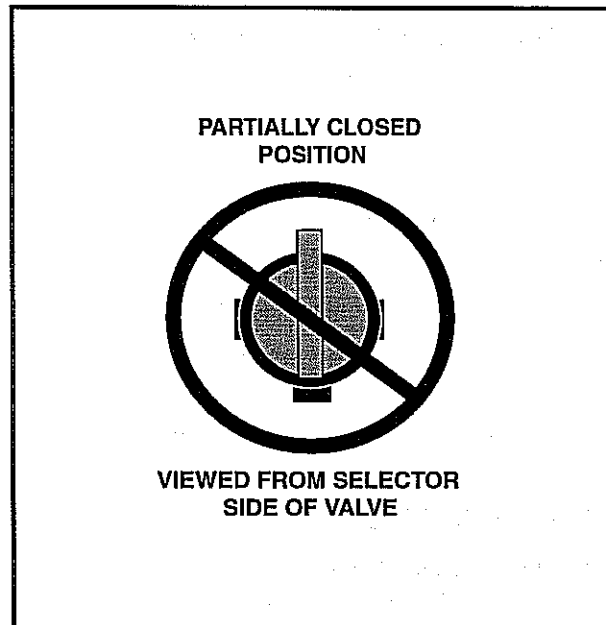

Figure 12 Fuel Valve – Partially Closed Position

## PREPARING THE VEHICLE FOR EXTENDED STORAGE

1. Unload the vehicle so that the tires are supporting only the weight of the vehicle.
2. Store the vehicle in a cool, dry place. This will minimize battery self-discharge. If the battery appears to be weak, have it charged by a trained technician. Use an automotive-type 12-volt battery charger rated at 10 amps or less. Check electrolyte level after charging and add distilled water if necessary.
3. Make sure the key switch is in the OFF position and the Forward/Reverse handle is in the NEUTRAL position. Chock the wheels.

### Gasoline vehicles:

4. Prepare the fuel tank.
  - 4.1. Fill the fuel tank with fresh fuel.
  - 4.2. Following manufacturer's directions, add a commercially available fuel stabilizer (such as Sta-Bil®). Run the engine in a well-ventilated area to allow treated fuel to replace untreated fuel in the carburetor.
  - 4.3. Disconnect the fuel vent line from the fuel tank vent nipple (**Figure 32, Page 42**).
  - 4.4. Plug the fuel tank vent nipple so that it is air tight. Husqvarna recommends using a slip-on vinyl cap.
5. Remove both spark plugs and pour 1/2 ounce (14.2 mL) of SAE 10 weight oil through each of the two spark plug holes. Rotate the engine crankshaft by hand several times, then install both spark plugs.

### Diesel vehicles:

6. Prepare the fuel tank.
  - 6.1. Fill the fuel tank with fresh fuel.
  - 6.2. Disconnect the fuel vent line from the fuel tank vent nipple (**Figure 33, Page 42**).
  - 6.3. Plug the fuel tank vent nipple so that it is air tight. Husqvarna recommends using a slip-on vinyl cap.
7. Change engine oil. **See Engine Oil and Filter Change on page 35.**

**All vehicles:**

8. Disconnect the battery cables, negative (–) cable first. **See WARNING “To avoid unintentionally starting...” on page 11.**
9. Batteries should be clean and free of corrosion. Wash tops and terminals of batteries with a solution of baking soda and water (1 cup (237 mL) baking soda per 1 gallon (3.8 L) of water). Rinse solution off batteries. Do not allow this solution to enter the batteries. Be sure terminals are tight. Let the terminals dry and then coat them with Battery Terminal Protector Spray (P/N 603 00 00-03).
10. Adjust the tires to the recommended tire pressure. **See Vehicle Specifications on page 47.**
11. Perform semiannual periodic lubrication. **See Periodic Lubrication Schedule on page 32.**
12. Thoroughly clean the front body, rear body, seats, cargo bed, engine compartment, and underside of vehicle.
13. Do not engage the park brake. Chock the wheels to prevent the vehicle from rolling.

**RETURNING THE STORED VEHICLE TO SERVICE**

1. Make sure the key switch is in the OFF position and the Forward/Reverse handle is in the NEUTRAL position. Chock the wheels.
2. Restore the fuel system to operation (**Figure 32, Page 42 or Figure 33, Page 42**).
  - 2.1. Remove the plug from the fuel tank vent.
  - 2.2. Connect the vent tube to the fuel tank vent.
3. Connect the battery cables, positive (+) cable first, and tighten the terminals to 20 ft-lb (27.1 N·m). Coat terminals with Battery Terminal Protector Spray (P/N 603 00 00-03).
4. **Gasoline vehicles only:** Completely open the fuel shut-off valve (**Figure 11**). Ensure the valve is fully open. A partially closed fuel shut-off valve combined with the use of the choke can result in a fouled spark plug and engine failure (**Figure 12**).
5. Place the Forward/Reverse handle in the NEUTRAL position. Crank the engine until fuel is pumped into the carburetor (gasoline vehicles) and the fuel lines and the engine starts. Turn the engine off. **See following NOTE.**

**NOTE:** *Due to the oil added to the engine in preparation for storage, the engine may smoke excessively for a short time when it is run for the first time after storage.*

6. Perform the Pre-Operation and Daily Safety Checklist on page 19.

**MAINTENANCE****See General Warnings on page 10.**

To ensure trouble-free vehicle performance, follow an established preventive maintenance program. Regular and consistent maintenance can prevent vehicle downtime and expensive repairs. Use the Pre-Operation and Daily Safety Checklist on page 19 and the following Periodic Service Schedule and Periodic Lubrication Schedule to keep the vehicle in proper working condition.

Any vehicle not functioning correctly should not be used until it is properly repaired. This will prevent further damage to the vehicle and avoid the possibility of injury due to unsafe conditions.

Contact your local Husqvarna dealer/distributor for repairs and semiannual and annual periodic service.

## **WARNING**

- Only trained technicians should service or repair the vehicle. Anyone doing even simple repairs or service should have knowledge and experience in electrical and mechanical repair. The appropriate instructions must be used when performing maintenance, service, or accessory installation.
- If any problems are found during scheduled inspection or service, do not operate vehicle until repairs are made. Failure to make necessary repairs could result in fire, property damage, severe personal injury, or death.
- Do not wear loose clothing or jewelry, such as rings, watches, chains, etc., when servicing vehicle.
- Turn key switch to the OFF position, remove the key, place the Forward/Reverse handle in the NEUTRAL position and chock the wheels prior to servicing.
- Moving parts: Do not attempt to service vehicle while engine is running.
- Hot! Do not attempt to service hot engine or exhaust system. Failure to heed this warning could result in severe burns.
- For vehicles with cargo beds, remove all cargo before raising the bed or servicing the vehicle. If the vehicle is equipped with a prop rod, ensure that it is securely engaged. Do not close bed until all persons are clear of cargo bed area. Keep hands clear of all crush areas. Do not drop cargo bed; lower gently and keep entire body clear. Failure to heed this warning could result in severe personal injury or death.
- Do not work on vehicle powertrain or under cargo bed when it is loaded.
- Gasoline vehicles only: Turn fuel shut-off valve to the closed (OFF) position (Figure 10).
- To help avoid unintentionally starting the vehicle:
  - Disconnect battery cables, negative (-) cable first (Figure 1, Page 9).
  - Gasoline vehicles only: Disconnect the spark plug wires from the spark plugs.
- If wires are removed or replaced make sure wiring and wire harness are properly routed and secured. Failure to properly route and secure wiring could result in vehicle malfunction, property damage, personal injury, or death.
- Lift only one end of the vehicle at a time. Use a suitable lifting device (chain hoist or hydraulic floor jack) with 1000 lb. (454 kg) minimum lifting capacity. Do not use lifting device to hold vehicle in raised position. Use approved jack stands of proper weight capacity to support the vehicle and chock the wheels that remain on the floor.
- When servicing the vehicle with part of the vehicle on jack stands, do not operate the engine with the Forward/Reverse handle in either the FORWARD or REVERSE position. The all-wheel drive system will engage any wheel(s), front or rear, with traction. See Figure 2 on page 11.

## **PERIODIC SERVICE SCHEDULE**

See General Warnings on page 10.

## **WARNING**

- Service, repairs, and adjustments must be made per instructions in the appropriate maintenance and service manual.

**NOTE:** If the vehicle is constantly subjected to heavy use or severe operating conditions, the preventive maintenance procedures should be performed more often than recommended in the Periodic Service and Lubrication Schedule.

Both the Periodic Service Schedule and the Periodic Lubrication Schedule must be followed to keep vehicle in optimum operating condition.

PERIODIC SERVICE SCHEDULE		
REGULAR INTERVAL	SERVICE	
Daily service by owner or trained technician	Engine	Check engine oil level; add if necessary. See Engine Oil Level Check on page 35.  Diesel vehicles: Check engine coolant; add if necessary. See Engine Coolant Level Check on page 40.
	Fuel filters	Diesel vehicles: Drain water from fuel filter. See Draining Water from Fuel Filter on page 42.
	Brakes	Check brake fluid; add if necessary. Check brake pedal for proper operation. See Performance Inspection on page 20.
Monthly service by owner or trained technician	Engine	Check engine circulating air passage; visually inspect unshrouded area around engine exhaust for grass and debris and clean if necessary. Diesel vehicles: Check for grass and debris around the radiator.
	Tires	Check air pressure and adjust if necessary. See Vehicle Specifications on page 47.
	Transmission and differentials	Check lubricant levels. Add if necessary. See Lubrication Level Check for Front Differential, Transmission, and Rear Differential on page 39.
	General vehicle	Wash engine compartment and underside of vehicle. Do not wash engine when hot.
First 20 hours, and every 100 hours thereafter	Engine	Gasoline vehicles: Adjust valve clearance. See Honda GX620 Service Manual (P/N 603 00 00-11)

**PERIODIC SERVICE SCHEDULE**

REGULAR INTERVAL	SERVICE	
Semiannual service by trained technician only (or every 50 hours of operation, whichever comes first)	Battery	Clean terminals and wash dirt from casing; check electrolyte level. Add distilled water if necessary. See page 44.
	Front wheel alignment and toe-in	Check and adjust if necessary. See Section 7 – Steering and Front Suspension in the appropriate maintenance and service manual.
	Electrical wiring and connections	Check for tightness and damage.
	Brake system	Inspect master cylinder, brake lines, and hoses for damage or leakage.
Check park brake cables for damage; replace if necessary.		
Check brake pads and discs; replace if necessary. See Section 6 – Brake System in the appropriate maintenance and service manual.		
Annual service by trained technician only (or every 100 hours of operation, whichever comes first)	Engine	Check for leaks around gaskets, fill plugs, etc.
		<b>Gasoline vehicles:</b> Inspect, clean, and gap spark plug; replace if necessary. See authorized Husqvarna dealer or trained technician for service.
		<b>Diesel vehicles:</b> Check the v-belt for proper tension or damage. Adjust or replace if necessary.
		<b>Diesel vehicles:</b> Change engine coolant. See Section 15 – Radiator and Cooling System in the maintenance and service manual.
	Radiator	<b>Diesel vehicles:</b> Check clamps for tightness; check hoses for cracks. Replace if necessary.
	Engine air intake system	Replace air filter element. See Air Intake System on page 40.
		Check clamps for tightness; check hose for cracks.
	General vehicle	Check for loose hardware and tighten if necessary.
Fuel filters	Replace. Dispose of used filters properly.	
1000 hours of operation	Brake system	Replace park brake cable.

**⚠ WARNING**

- If any problems are found during scheduled inspection or service, do not operate the vehicle until repairs are made. Failure to make necessary repairs could result in fire, property damage, severe personal injury, or death.

## PERIODIC LUBRICATION SCHEDULE

PERIODIC LUBRICATION SCHEDULE			
REGULAR INTERVAL	SERVICE	LUBRICATION POINTS	RECOMMENDED LUBRICANT
Gasoline vehicle: First change 20 hours – Diesel vehicle: First change 50 hours – additional change for both every 100 hours of operation or annually, whichever comes first	Change engine oil and oil filter	1	Gasoline vehicles: 1 qt.-25 oz. (1.7 L) with filter Diesel vehicles: 3 qt. (2.8 L) with filter See Oil Viscosity on page 38.
Monthly by owner or trained technician	Driveshaft	2	Chassis Lube (EP NLGI Grade 2)
Semiannually by owner or trained technician (or every 50 hours of operation, whichever comes first)	Check/add brake fluid	3	Use only DOT 5 (silicone) brake fluid
	Rear suspension (2 fittings)	4	Chassis Lube (EP NLGI Grade 2)
First change 50 hours – additional change every 100 hours of operation or annually, whichever comes first	Change front differential lubricant	5	5 oz. (150 mL) Mobil 424, Exxon Hydraul 560, or Esso Hydraul 56 lubricant
First change 50 hours – additional change every 300 hours of operation or annually, whichever comes first	Change rear differential lubricant	6	20 oz. (600 mL) Mobil 424, Exxon Hydraul 560, or Esso Hydraul 56 lubricant
	Change transmission lubricant	7	20 oz. (600 mL) Mobil 424, Exxon Hydraul 560, or Esso Hydraul 56 lubricant

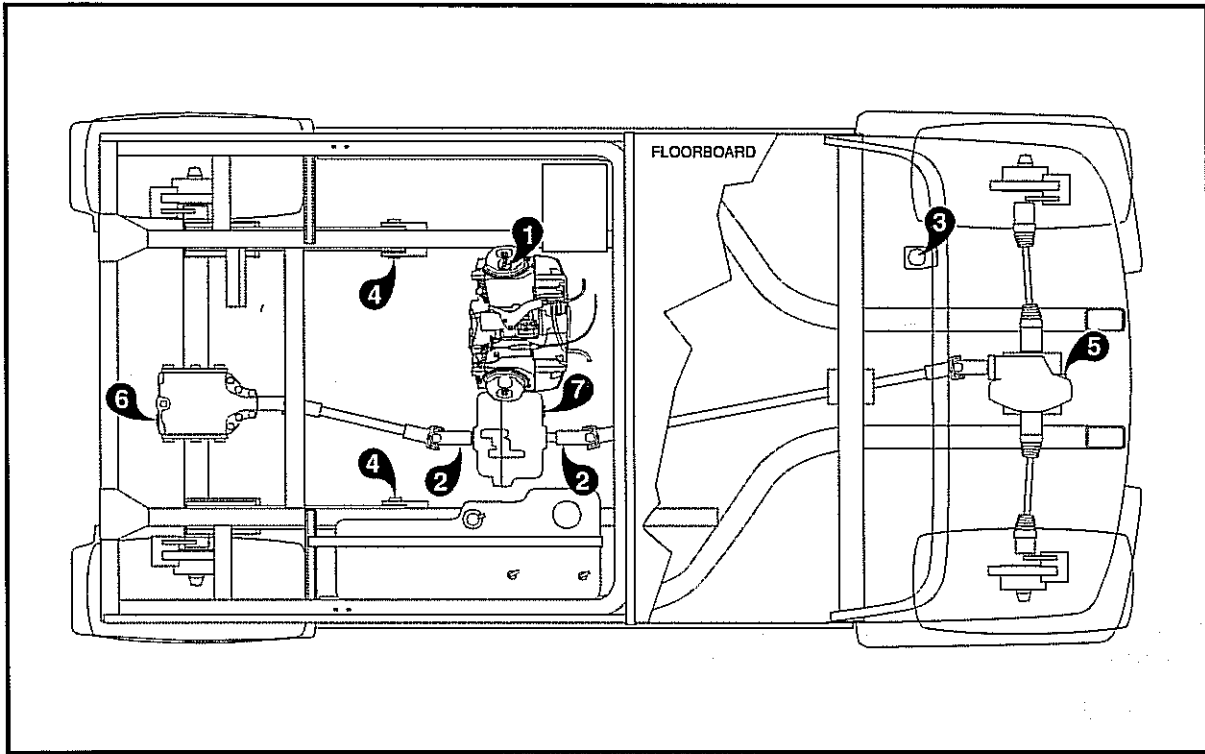

Figure 13 Lubrication Points – Gasoline Vehicles

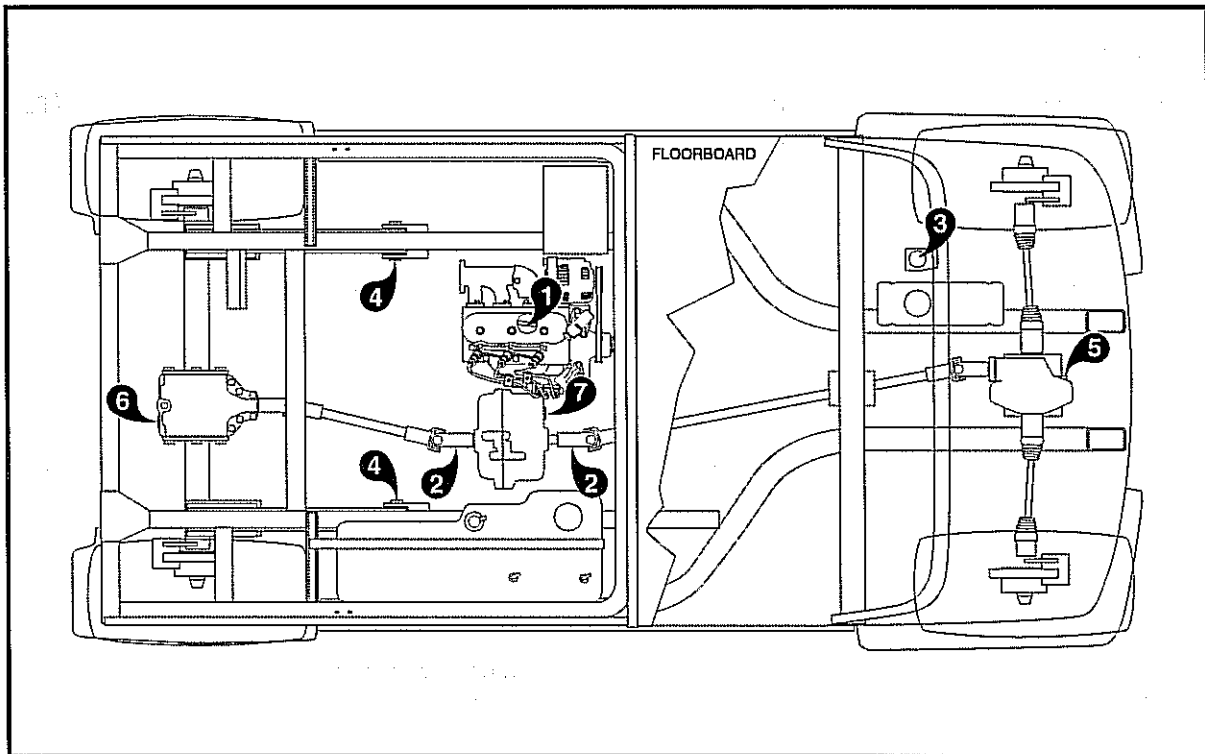

Figure 14 Lubrication Points – Diesel Vehicles

## BRAKE FLUID RESERVOIR

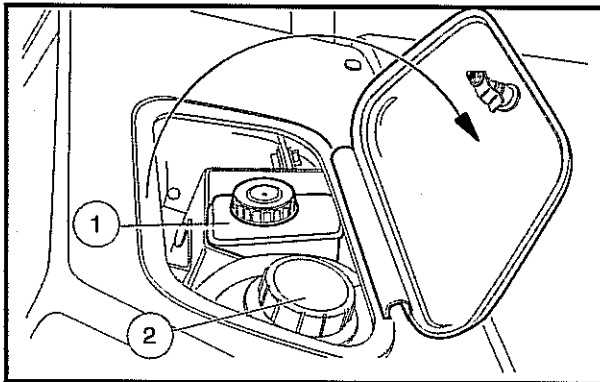

Figure 15 Brake Fluid and Coolant Access Door

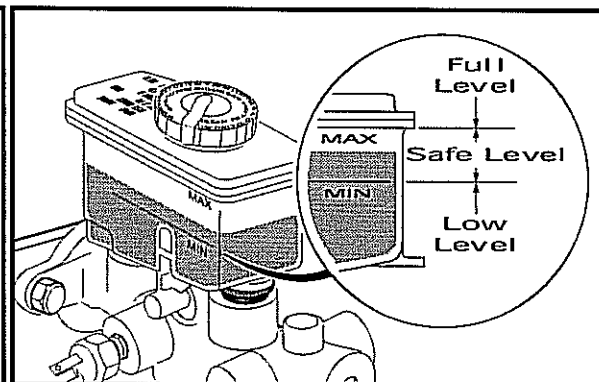

Figure 16 Brake Fluid Reservoir

The brake fluid reservoir (1) is located under the dashboard (**Figure 15**). Raise the access panel located on top of the dashboard to check the brake fluid level.

When checking the brake fluid, also inspect the following:

- The presence of brake fluid on the exterior surface of the master cylinder indicates a leak.
- The brake fluid reservoir diaphragm (located in the cap) should not have holes or other damage.

## BRAKE FLUID

Brake fluid level should be within 1/4-inch (6 mm) from the top of the reservoir (**Figure 16**). Also, brake fluid should be clean with no residue in the bottom of the reservoir or other evidence of contamination.

### **▲ CAUTION**

- Use only DOT 5 (silicone) brake fluid. Use of any other type brake fluid is not recommended.

## ENGINE OIL

Even though the low oil warning light on the instrument panel should illuminate if the oil level becomes low, the engine oil level should be checked daily. The vehicle should be on a level surface when the oil is checked. Do not overfill with oil.

## OIL PRESSURE – GASOLINE ENGINE

The gasoline engine has an oil filter that is mounted on a bracket next to the back side of the front panel. Inlet and outlet oil-carrying hoses enable oil circulation to and from the engine. **See following NOTE.**

**NOTE:** The normal oil pressure value stated in the Honda engine manual is 28 psi at idle; however, the remote filter design causes oil pressure to be 18 psi, which is normal for this type of oil circulation design.

## ENGINE OIL LEVEL CHECK

1. Remove the oil level dipstick from the oil filler tube and wipe oil from the dipstick. See Figure 17 or Figure 18. See following CAUTION.

### **CAUTION**

- Do not remove dipstick while engine is running.
2. Check oil level by fully inserting the dipstick into the tube and immediately removing it.
  3. If the oil level is at or below the low level mark on the dipstick gauge, add oil until the level is between low and full levels (safe level). See following CAUTION.

### **CAUTION**

- Do not fill oil above the full level mark. Doing so will result in decreased engine performance or damage to the engine.

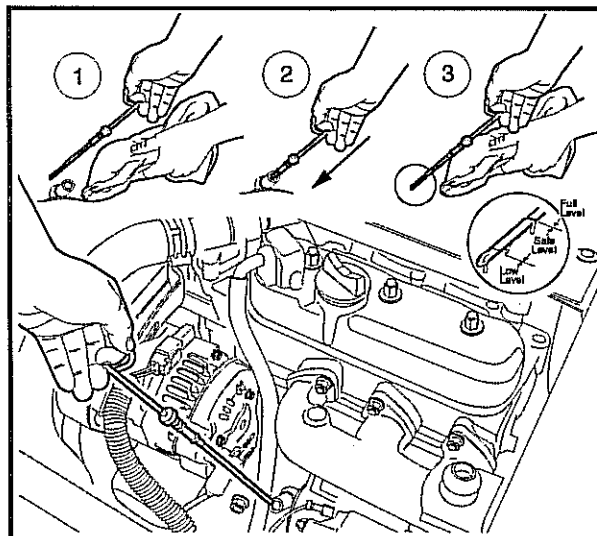
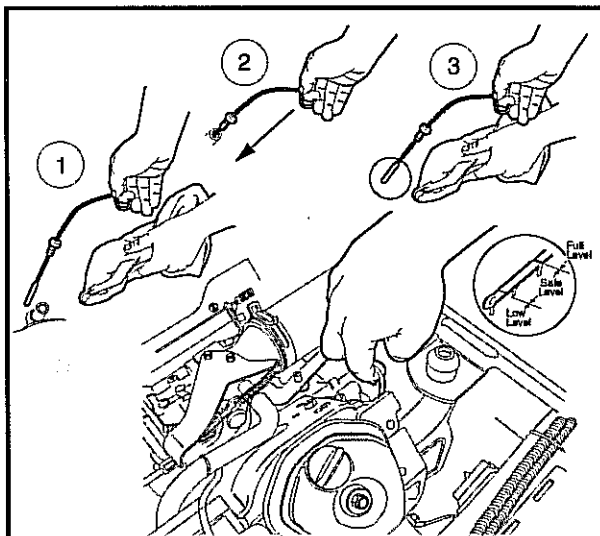

Figure 17 Engine Oil Level Check – Gasoline Vehicles

Figure 18 Engine Oil Level Check – Diesel Vehicles

## ENGINE OIL AND FILTER CHANGE

Engine oil and oil filter should be changed after the first 20 hours of operation (gasoline) or 50 hours of operation (diesel). After that, they should be changed every 100 hours of operation or annually, whichever comes first.

### Engine Oil Draining

1. Turn the key switch to the OFF position and remove the key. Place the Forward/Reverse handle in the NEUTRAL position. Chock the front wheels.
2. Disconnect the battery cables, negative (–) cable first. See **WARNING** “To avoid unintentionally starting...” on page 12.
3. Remove the oil filler cap to allow the oil to drain properly.
4. Position a pan designed for oil changes under the drain plug (Figure 19 or Figure 21).

- From the underside of the vehicle, use a socket- or box-end (do not use an open-end) wrench to remove the drain plug (1). Turn the plug counterclockwise and drain the engine oil into the pan. **See following WARNING.**

**▲ WARNING**

- Do not attempt to change engine oil when the engine is hot or even warm. Hot engine oil can cause skin burns.
  - Wear safety glasses or approved eye protection when servicing the vehicle. Wear rubber gloves when handling oil drain plug, oil filter, and oil drain pan.
- Clean the oil drain plug threads with solvent to remove oil and oil residue. Make sure that the compression washer remains on the drain plug. Inspect the compression washer and replace if necessary.
  - Use a socket- or box-end (do not use an open-end) wrench to replace the oil drain plug. Turn the plug clockwise and tighten to 29 ft-lb (40 N·m) for gasoline vehicles, 31 ft-lb (42 N·m) for diesel vehicles.

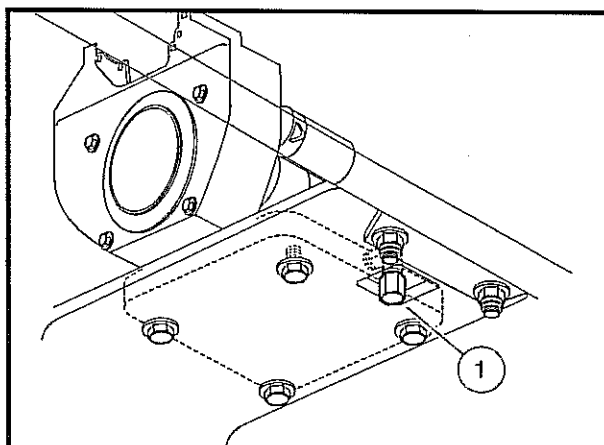

Figure 19 Engine Oil Drain Plug and Pan – Gasoline Vehicles

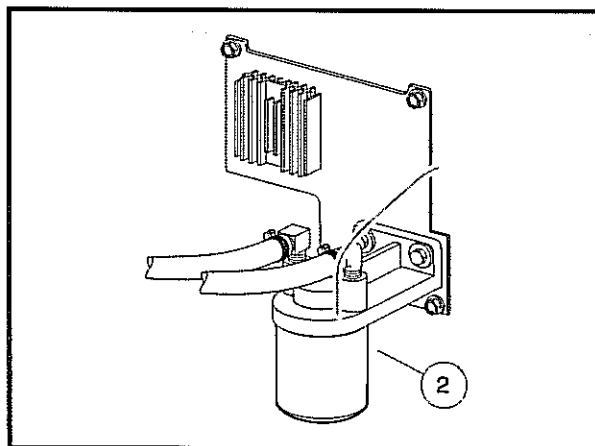

Figure 20 Replace Engine Oil Filter – Gasoline Vehicles

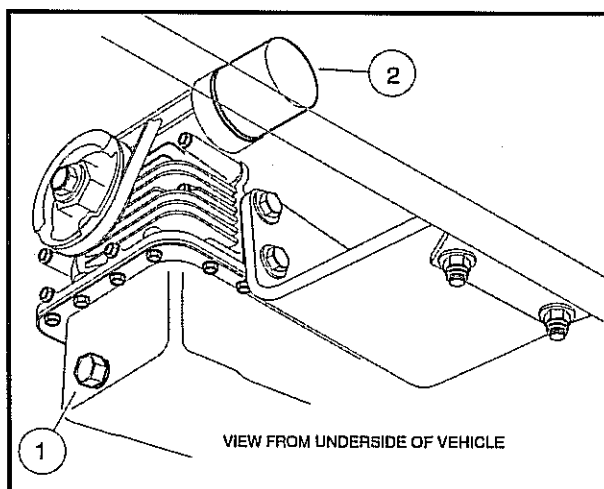

Figure 21 Engine Oil Drain Plug and Oil Filter – Diesel Vehicles

## Engine Oil Filter Change

1. Drain the engine oil. See **Engine Oil Draining** on page 35.
2. Place the oil drain pan under the engine oil filter (2) (**Figure 20** or **Figure 21**).
3. Remove the engine oil filter. Turn it counterclockwise and drain the residual oil in the filter port and filter into the oil drain pan. See following **NOTE**.

**NOTE:** An oil drip guard can be used to prevent excess oil from dripping onto the engine base plate. Use an empty quart (liter) container and cut the bottom off at an angle, then slide the open area of the container up and under the oil filter before removal. Position the port of the plastic container so oil will be directed into the oil pan (**Figure 22**). A drip guard can be made by folding a piece of cardboard, thin metal, or plastic under the oil filter, forming a channel to direct the filter port oil into the drain pan.

Dispose of used oil according to the environmental laws and regulations for your area.

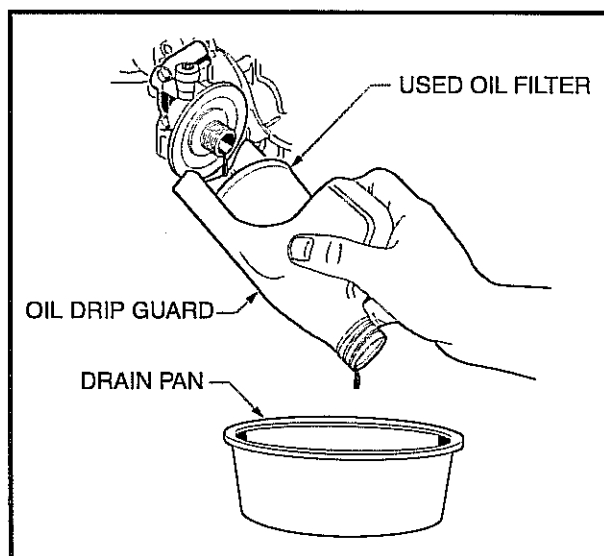

Figure 22 Remove Engine Oil Filter

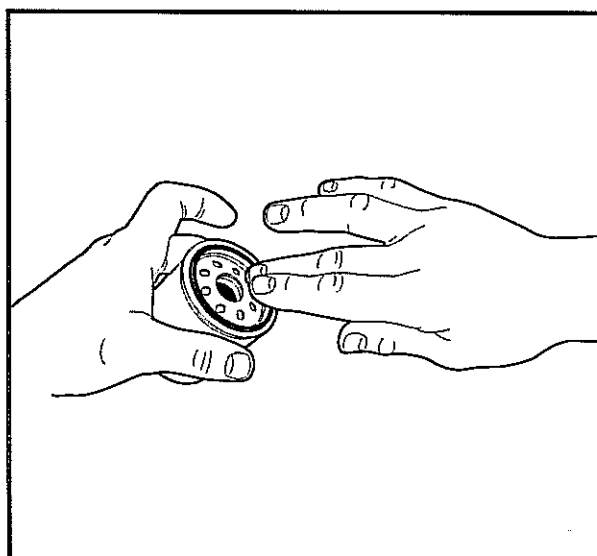

Figure 23 Coat Rubber Seal

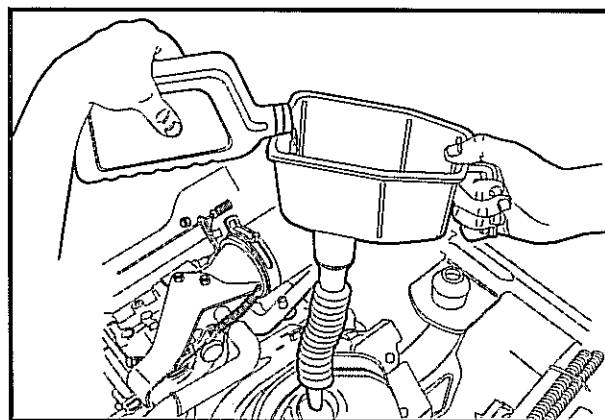

Figure 24 Add Engine Oil – Gasoline Vehicles

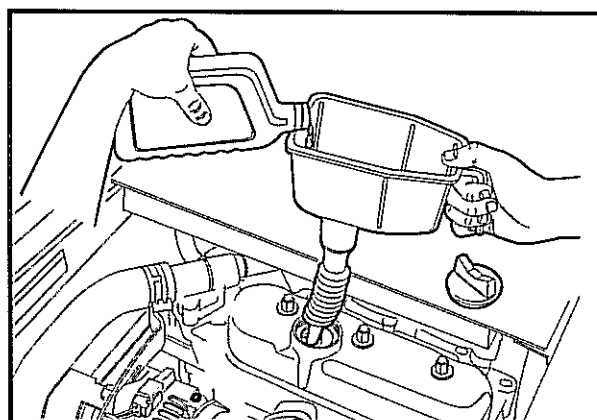

Figure 25 Add Engine Oil – Diesel Vehicles

4. Use a clean, lint-free rag to wipe the oil filter port flange surface clean where the oil filter gasket seats.
5. To help seal the new oil filter to the oil port flange, apply a light coat of white lithium NLGI Number 2 grease (Dow Corning® BR2-Plus or equivalent) or new engine oil to the rubber seal around the outside surface of the filter before attaching it to the oil filter port (**Figure 23**). Install the new oil filter (gas: P/N 603 00 00-09, diesel: P/N 603 00 00-12) onto the engine oil filter port. **See following NOTE.**

**NOTE:** Use only Husqvarna oil filters designed for your engine.

6. Tighten the oil filter by hand 2/3 turn after gasket contact. Do not use a band wrench or channel lock pliers.

## Engine Oil Filling

1. Add engine oil; use a funnel or pour spout to direct the oil into the opening (**Figure 24 or Figure 25**). With filter change, the engine requires 1 qt.-25 oz. (1.7 L) of oil per change for gasoline vehicles and 3 qt. (2.8 L) for diesel vehicles. Refer to oil viscosity guidelines for selection of oil grade (**Figure 26 or Figure 27**). **See following CAUTION.**

### CAUTION

- Do not exceed recommended oil capacity. Doing so will decrease engine performance or result in damage to the engine.
2. Connect the battery cables, positive (+) cable first, and tighten terminals to 20 ft-lb (27.1 N·m). Coat terminals with Battery Terminal Protector Spray (P/N 603 00 00-03).
  3. With the Forward/Reverse handle in the NEUTRAL position, start and run the engine for a few minutes. Observe both the drain plug and the oil filter from under the vehicle and watch for oil leaks. If a leak is detected, check the tightness of the oil filter and drain plug. Tighten, repair, and/or replace components as necessary.

**NOTE:** Wait five minutes after turning off the engine before removing the dipstick.

4. Remove the dipstick and check the engine oil as a final step. Replace the dipstick.

## OIL VISCOSITY

Choose the viscosity according to the temperature as shown in the appropriate oil viscosity chart (**Figure 26 or Figure 27**). Using multi-grade oils (5W-20, 10W-30, and 10W-40) will increase oil consumption. If multi-grade oil is used, check the oil level more frequently. **See following NOTE.**

**NOTE:** Use engine oil with API classification SJ for gasoline engines and CF for diesel engines.

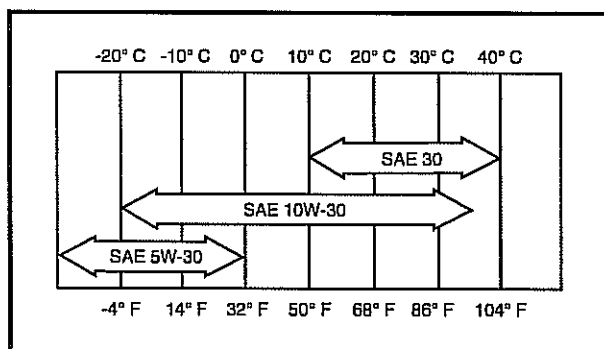

Figure 26 Oil Viscosity Chart – Gasoline Vehicles

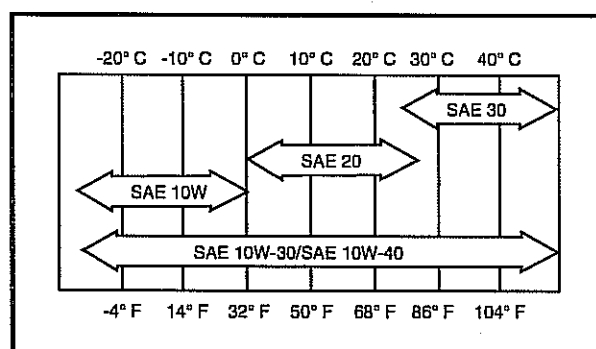

Figure 27 Oil Viscosity Chart – Diesel Vehicles

## GEARCASE LUBRICATION

**NOTE:** Dispose of used oil according to the environmental laws and regulations for your area.

### LUBRICATION LEVEL CHECK FOR FRONT DIFFERENTIAL, TRANSMISSION, AND REAR DIFFERENTIAL

Each gearcase component is equipped with two oil port plugs (1 and 2) (Figure 28, Figure 29, and Figure 30). When the vehicle is on a level surface, use the level indicator hole (upper plug) (1) as a lubricant level indicator. Lubricant level should be even with the bottom of level indicator hole (1).

### LUBRICATION CHANGE FOR FRONT DIFFERENTIAL, TRANSMISSION, AND REAR DIFFERENTIAL

Use the lower plug (2) for drainage (Figure 28, Figure 29, or Figure 30). Remove both plugs to allow the lubricant to drain faster. See preceding NOTE.

#### Front differential:

Clean and install the drain plug (2) and washer before filling the front differential with new lubricant (Figure 28). Tighten the drain plug to 11 ft-lb (14.9 N·m). Use a funnel when filling the gearcase through the lubricant level indicator hole (1). See Periodic Lubrication Schedule on page 32. Tighten the level indicator plug to 10 ft-lb (13.6 N·m).

#### Transmission:

Clean and install the drain plug (2) before filling the transmission with new lubricant (Figure 29). Tighten the drain plug to 8 ft-lb (10.8 N·m). Use a funnel when filling the transmission through the lubricant level indicator hole (1). See Periodic Lubrication Schedule on page 32. Apply Loctite 567 to the threads of the level indicator plug and tighten the plug to 21.0 ft-lb (28.5 N·m).

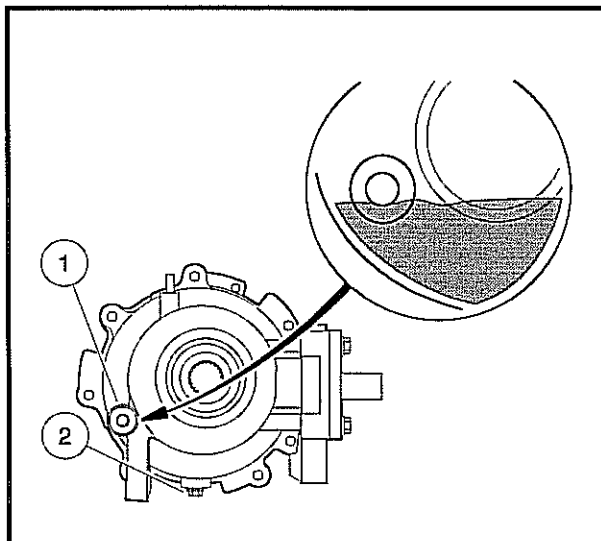

Figure 28 Front Differential Lubrication Level

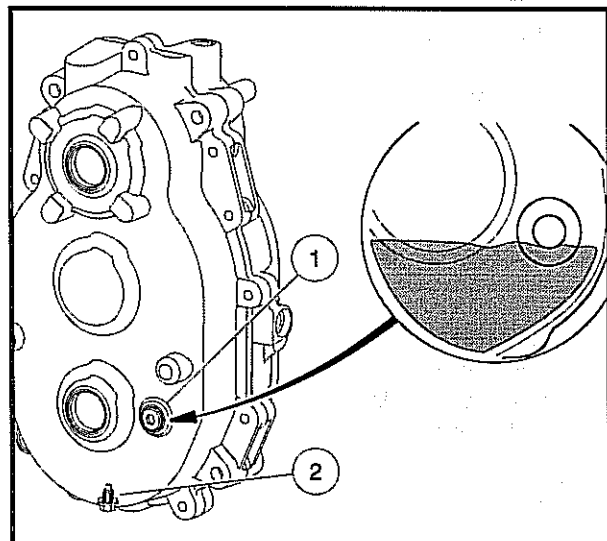

Figure 29 Transmission Lubrication Level

### Rear differential:

Clean and install the drain plug (2) and washer before filling the rear differential with new lubricant (**Figure 30**). Tighten the drain plug to 8 ft-lb (10.8 N·m). Use a funnel when filling the rear differential through the lubricant level indicator hole (1). **See Periodic Lubrication Schedule on page 32.** Apply Loctite 567 to the threads of the level indicator plug and tighten the plug to 21.0 ft-lb (28.5 N·m).

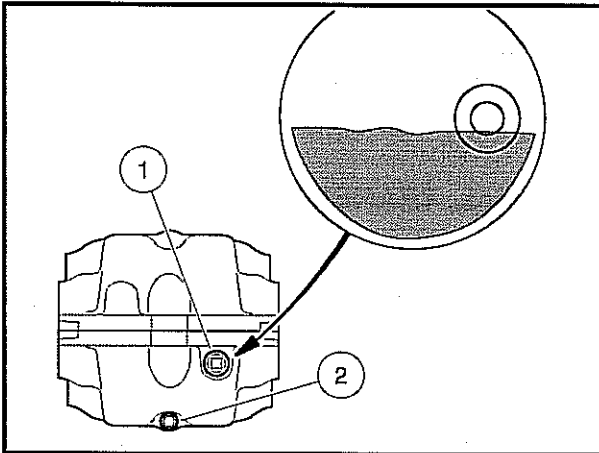

Figure 30 Rear Differential Lubrication Level

## ENGINE COOLANT – DIESEL VEHICLES

### ENGINE COOLANT LEVEL CHECK

The coolant reserve tank is located under the dashboard next to the brake fluid reservoir (**Figure 15**). Raise the access panel located on top of the dashboard to check the coolant level before every operation.

1. Check the coolant level of the reserve tank (2). If the coolant is at or below the LOW mark, add water until level reaches the FULL mark. If a leak is detected, have it checked by a trained technician. **See following WARNING.**

#### **▲ WARNING**

- Hot! Coolant reserve tank is pressurized. Do not remove cap when engine is hot.

### AIR INTAKE SYSTEM

#### **CAUTION**

- Do not drill into the driver-side frame. Failure to heed this caution could damage the engine by allowing excessive contamination to enter the air intake system.

### AIR FILTER REPLACEMENT

The air filter should be inspected periodically and replaced when necessary. Filter changes should not exceed the recommended interval. **See Periodic Service Schedule on page 29.** More frequent service may be

required in extremely dirty operating environments. In the event of a loss of power, sluggish acceleration, or a roughly running engine, service the air filter immediately.

### Air Filter Removal

1. Release both canister tab lock (Figure 31).
2. Pull the canister cap away from the canister.
3. Remove the air filter cartridge. See following NOTE.

**NOTE:** The air filter cartridge is specifically designed for this engine. It only fits into the canister one way. Use only the Husqvarna part (PIN 603 00 00-10) designed for this engine.

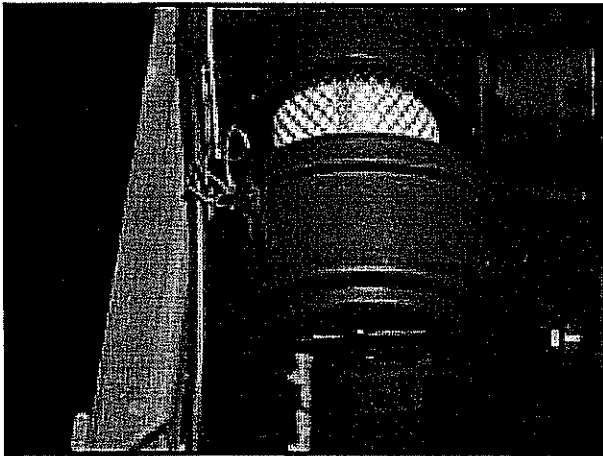

Figure 31 Air Filter Cartridge

### Air Filter Installation

1. Push the new air filter cartridge onto the inside canister nozzle.
2. Place the canister cap, marked TOP, on the top center of the canister.
3. Secure the canister cap with both tab locks.
4. Push the yellow tab lock in to secure canister cap.

## FUELING INSTRUCTIONS

See General Warnings on page 10.

### **⚠ DANGER**

- Turn key switch to the OFF position before fueling.
- Never pour fuel into the fuel tank when the engine is hot or while it is running.

DANGER CONTINUED ON NEXT PAGE...

## **⚠ DANGER**

- To avoid electric arc caused by static electricity, the fuel storage/pumping device must be grounded. If the pump is not grounded, the vehicle must be grounded to the pump before and during the fueling operation.
- To avoid the possibility of fire, clean up any spilled fuel before operating the vehicle.

1. Remove the fuel cap and fill the tank with fuel. Gasoline vehicles have a black fuel cap; diesel vehicles have a green fuel cap. See preceding **DANGER** and following **NOTE**.

**NOTE: Gasoline vehicles:** Use unleaded gasoline only. Whenever possible, avoid using oxygenated fuels and fuels that are blended with alcohol.

**Diesel vehicles:** Use only diesel fuel grade no. 2 with a cetane rating of 45 or higher.

2. Replace the fuel cap. Ensure that the cap is tightened securely.
3. Clean any spilled fuel from the cap or around the fuel cap area.

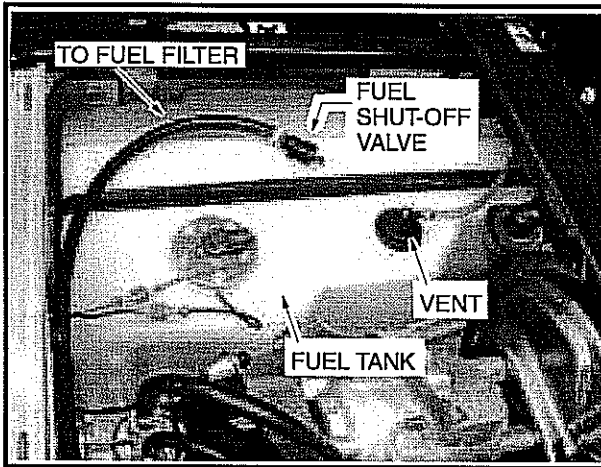

Figure 32 Fuel Tank – Gasoline Vehicles

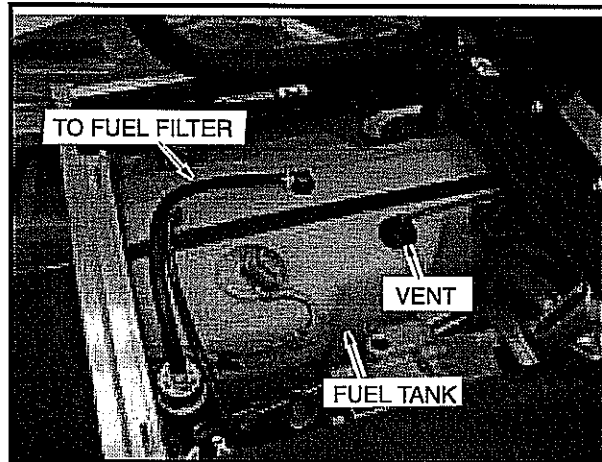

Figure 33 Fuel Tank – Diesel Vehicles

## **DRAINING WATER FROM FUEL FILTER**

### **Diesel Vehicles Only**

Water should be drained from the fuel filter daily. The fuel filter is mounted on a plate by the lower seat support panel (Figure 34).

1. Position a pan under the fuel filter.
2. Lift the passenger-side seat.
3. Locate the valve (1) on the underside of the filter. Turn the valve clockwise until water begins to stream from the filter.
4. Drain the water until it changes color (to fuel). See following **WARNING**.

## **⚠ WARNING**

- Clean up spilled fuel. Keep sparks and flames away from the vehicle and service area. Failure to heed this warning could result in an explosion or fire, resulting in severe personal injury or death.

5. Close the valve by rotating it counterclockwise until the valve is firmly sealed.
6. To resupply the filter with fuel, turn the key switch to the ON position for 10 seconds. **See following NOTE.**

**NOTE:** Dispose of water according to the environmental laws and regulations for your area.

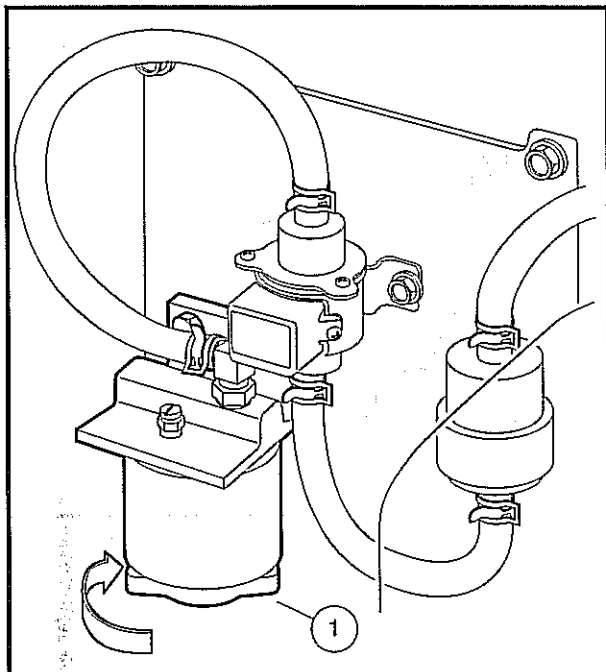

Figure 34 Fuel Filter

## BATTERY

See General Warnings on page 10.

### **⚠ DANGER**

- **Battery – Explosive gases!** Do not smoke. Keep sparks and flames away from the vehicle and service area. Ventilate when charging or operating vehicle in an enclosed area. Wear a full face shield and rubber gloves when working on or near batteries.
- Tools, wires, and metal objects can cause sparks when shorted across a battery.
- Follow all instructions carefully when working with batteries.
- Charge battery in a well-ventilated area only.
- **Battery – Poison!** Contains acid! Causes severe burns. Avoid contact with skin, eyes, or clothing. Antidotes:
  - External: Flush with water. Call a physician immediately.
  - Internal: Drink large quantities of milk or water followed with milk of magnesia or vegetable oil. Call a physician immediately.
  - Eyes: Flush with water for 15 minutes. Call a physician immediately.

**⚠ WARNING**

- Do not jump-start a dead battery using another battery and jumper cables.

The battery in a Husqvarna vehicle is a 12-volt, low-maintenance battery that requires infrequent checks (Figure 35). Electrolyte level should be checked semiannually.

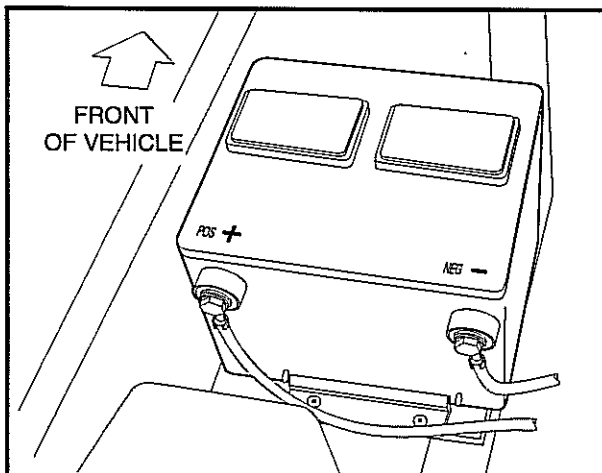

Figure 35 Battery

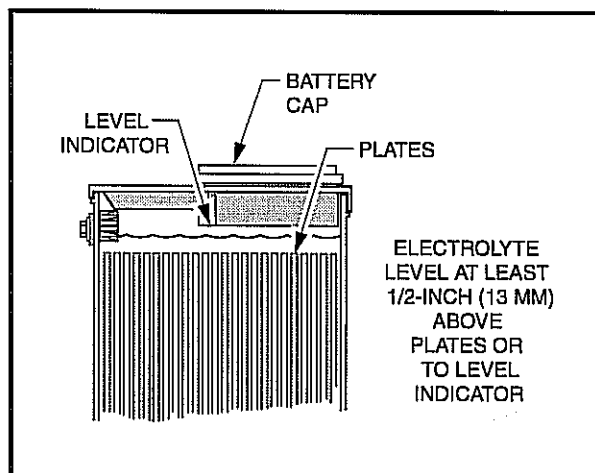

Figure 36 Battery Electrolyte Level

1. Turn the key switch to the OFF position and remove the key. Place the Forward/Reverse handle in the NEUTRAL position. Chock the wheels.
2. Access the engine compartment. See **WARNING** "For vehicles with cargo beds..." on page 10.
  - 2.1. Remove the driver-side seat.
3. Disconnect the battery cables, negative (–) cable first. See **WARNING** "To avoid unintentionally starting..." on page 11.
4. Use a flat-blade screwdriver, and carefully remove the battery cell caps from the battery. See following **WARNING**.

**⚠ WARNING**

- Wear safety glasses or approved eye protection when servicing the vehicle. Wear a full face shield and rubber gloves when working on or near batteries.
5. Carefully check the electrolyte level and add distilled water if necessary. Do not fill above designated fill line. Replace battery cell caps.
  6. Clean both battery terminals with a solution of baking soda and water (1 cup (237 mL) baking soda per 1 gallon (3.8 L) of water). Rinse thoroughly. Do not allow this solution to enter the battery. Tighten battery terminals to 20 ft-lb (27.1 N·m). Let the terminals dry and then spray them with Battery Terminal Protector Spray (P/N 603 00 00-03). See following **CAUTION**.

**⚠ CAUTION**

- If battery wire terminals are damaged or corroded, replace or clean them as necessary. Failure to do so may cause them to overheat during operation.

Be sure battery hold-down clamp is properly tightened. Tighten to 9 ft-lb (12.2 N·m). A loose clamp may allow the battery to become damaged from vibration or jarring.

If battery appears weak, have it charged by a trained technician. The battery should never be left discharged any longer than absolutely necessary (do not leave discharged overnight).

## CLEANING THE VEHICLE

---

Each standard vehicle is equipped with an ABS/DR acrylic front body and a steel rear body.

**NOTE:** *Camouflage vehicles are equipped with an all-aluminum rear body.*

The vehicle has a powder-coated steel cargo bed. Use commercial automotive cleaning solutions with a sponge or soft cloth for normal cleaning. A garden hose at normal residential water pressure is adequate. To remove oxidation or discoloration from aluminum, use a commercially available aluminum cleaner paste and fine grade (No. 00) steel wool.

Husqvarna does not recommend any type of pressure washing or steam cleaning. Such a process will expose electrical components to moisture. Moisture entering electrical components can result in water damage and subsequent component failure.

Use non-abrasive wax products. Battery acid, fertilizers, tars, asphalt, creosote, paint, or chewing gum should be removed immediately to prevent possible stains.

The front body is made of an ABS/DR acrylic cap material similar to the material used to manufacture hot tubs and shower/tub units. Cleaning and repair techniques for the front body are the same as those used on conventional acrylic sheet. Use cleaning and polishing products available at any hardware store where ABS/DR acrylic (hot tubs and shower/tub units) are sold.

The seats of the vehicle will last longer with proper cleaning. Use a solution of 10% liquid soap and warm water applied with a soft cloth. For imbedded dirt, a soft bristle brush may be used. For heavy soiling, difficult stains, or scratches, blemishes, or other body damage, see the appropriate maintenance and service manual. **See following NOTE.**

**NOTE:** *Dispose of waste water properly.*

## ACCESSORIES

---

There is a complete line of accessory equipment available from Husqvarna and our dealers/distributors. You can obtain the name and phone number of your closest Husqvarna contact by visiting our web site at [www.usa.husqvarna.com](http://www.usa.husqvarna.com).

Care should be taken that these accessories are properly installed by trained technicians, and that they are used in the manner for which they were designed. **See following WARNING and CAUTION.**

### **▲ WARNING**

---

- Custom cab assemblies, canopy tops, weatherproof enclosures, and windshields will not protect occupants from flying objects.
- If the vehicle is equipped with an electric-powered bed lift, remove the bed before servicing the bed lift system.

## **CAUTION**

- Do not drill into the driver-side frame. Failure to heed this caution could damage the engine by allowing excessive contamination to enter the air intake system.

## **ELECTRIC WINCH ACCESSORY**

If your vehicle is equipped with an electric winch, read and follow all manufacturer safety warnings and instructions in the winch operator manual, as well as the following WARNING and CAUTION statements. Make sure a winch warning decal is affixed to the vehicle on the seat support panel next to the receptacle for the remote operation switch. See **Safety Decal Identification beginning on page 4**.

The winch kit available from Husqvarna includes a remote operation switch, which enables the operator to move away from the vehicle and cable. See following **WARNING** and **CAUTION**.

### **▲ WARNING**

- Before beginning a winch operation:
  - Turn key switch to the OFF position, put Forward/Reverse handle in the NEUTRAL position, and engage the park brake.
  - Do not use winch while persons are seated on the vehicle.
- Stand to the side and away from the vehicle to operate winch.

## **CAUTION**

- Use of the winch for an extended period of time could discharge the battery. Keep winch operations as short as possible, and drive the vehicle for several minutes after the winch operation to recharge the battery.

## **MUD TIRE OPTION**

All-wheel drive (AWD) vehicles equipped with optional mud tires are intended only for off-road operation; they are not designed for use on paved surfaces such as asphalt and concrete. Frequent driving on paved surfaces will significantly decrease the life of the mud tires. Vehicle performance will also be reduced when driving on paved surfaces. See following **WARNING**.

### **▲ WARNING**

- To avoid the risk of rollover when operating a vehicle equipped with mud tires on a paved surface: reduce speed, use extreme caution, and drive slowly in turns.

Husqvarna tires are made specifically for the AWD vehicle; therefore, Husqvarna recommends that only tires purchased from Husqvarna be used on your AWD vehicle.

## **SUBSEQUENT OWNER REGISTRATION**

---

In the event a vehicle is bought as a used vehicle, we strongly urge the new owner to register the vehicle with Husqvarna. This will enable us to contact you if the need arises. Please send your name, address, and serial number of the vehicle to Husqvarna, 7349 Statesville Rd., Charlotte, NC 28269, Attention: Vehicle Registration.

## VEHICLE SPECIFICATIONS

SPECIFICATIONS	GASOLINE VEHICLES	DIESEL VEHICLES
<b>POWER SOURCE</b>		
Engine: 4-cycle OHV, 614 cc, 20 hp rated, twin-cylinder, air-cooled, with pressure lubrication system	.	.
Engine: 4-cycle OHV, 719 cc, 20 hp rated, three-cylinder, liquid-cooled, with pressure lubrication system	.	.
Fuel system: Side-draft carburetor with float bowl, fixed jets, fuel filters, and impulse fuel pump	.	.
Fuel system: Mechanical injection, fuel water separator, fuel filters, and electric fuel pump	.	.
Governor: Automatic ground-speed sensing, internally geared in transmission	.	.
Governor: Internal to engine, mechanical, centrifugal ball	.	.
Ignition: Transistor electronic ignition	.	.
Transmission: Forward and reverse with neutral (4.98:1 forward, 7.79:1 reverse)	.	.
Electrical system: 12 volt, 500 cca at 0 °F (-17.8 °C), 650 at 32 °F (0 °C), 105-minute reserve capacity and 35-amp charging capacity	.	.
Torque converter: Automatic, variable-speed, dry type	.	.
<b>STEERING/SUSPENSION/BRAKES</b>		
Steering: Self-adjusting rack and pinion, Ackerman	.	.
Suspension: Front: Independent A-arms with coil-over shock absorbers Rear: Semi-independent suspension with multi-leaf springs and dual hydraulic shock absorbers	.	.
Brakes: Hydraulic brake system – brake pads and discs on each wheel with separate foot-operated park brake	.	.
<b>BODY/CHASSIS</b>		
Frame/Chassis: Twin I-Beam welded aluminum tube frame	.	.
Side and rear body: Steel (standard vehicles); all aluminum (camouflage vehicles)	.	.
Cargo bed: Powder-coated steel	.	.
Front body: ABS/DR acrylic cap	.	.
Tires: All Terrain: 23 x 8.0 – 12 front, 23 x 10.5 – 12 rear; tubeless, 4-ply rated load range Mud: 23 x 10.5 – 12 front and rear; tubeless, 4-ply rated load range	.	.
<b>DIMENSIONS/WEIGHT</b>		
Overall length (box bed configuration)	124.6 in. (317 cm)	
Overall width	57.8 in. (147 cm)	
Overall height (with cab frame)	77.6 in. (197 cm)	
Wheelbase	81 in. (206 cm)	
Ground clearance: under differential under floorboard	6.4 in. (16 cm) 11.1 in. (28 cm)	
Front wheel tread	42.3 in. (107 cm)	
Rear wheel tread	48.8 in. (124 cm)	
Weight (with all-terrain tires)	1410 lb. (639.6 kg)	1551 lb. (703.5 kg)
Forward speed	25 mph (40 km/h)	
Governed RPM	3825	3825
Turning radius (per SAE J 695)	141 in. (358 cm)	
Specifications continued on next page..		

SPECIFICATIONS	GASOLINE VEHICLES	DIESEL VEHICLES
Load bed height	33 in. (84 cm)	
Load bed size (box bed inside dimensions)	48.0 x 49.8 x 10.9 in. (122 x 127 x 28 cm) (15.3 cubic feet)	
Maximum payload capacity (level surface only)	800 lb. (363 kg) High capacity option: 1050 lb. (476 kg)	
Vehicle rated capacity (payload, driver, and passenger; level surface only)	1200 lb. (544 kg) High capacity option: 1450 lb (658 kg)	
Maximum gross vehicle weight (fully loaded vehicle, including accessories)	2750 lb. (1247 kg) High capacity option: 3012 lb. (1366 kg)	
Standard seating capacity	2	
<b>LIQUID CAPACITIES</b>		
Engine crankcase with filter: SAE 10W-30, API classification SJ	1 qt.-25 oz. (1.7 L)	
Engine crankcase with filter: SAE 10W-30, API classification CF		3 qt. (2.8 L)
Front differential: Mobil 424, Exxon Hydraul 560, or Esso Hydraul 56 lubricant	5 oz. (150 mL)	
Rear differential: Mobil 424, Exxon Hydraul 560, or Esso Hydraul 56 lubricant	20 oz. (600 mL)	
Transmission: Mobil 424, Exxon Hydraul 560, or Esso Hydraul 56 lubricant	20 oz. (600 mL)	
Engine coolant: mixture of 55% propylene glycol and 45% water	n/a	2 gal. (7.6 L)
Brake fluid: DOT 5 (silicone) brake fluid	8 oz. (240 ml)	
Fuel tank: unleaded gasoline	6.5 gallons (24.6 L)	
Fuel tank: diesel grade no. 2 with cetane rating of 45 or higher		6.5 gallons (24.6 L)
<b>TIRE PRESSURE</b>		
All-terrain tread	20 - 22 psi (1.38 - 1.52 Bars)	
Mud tires	20 - 22 psi (1.38 - 1.52 Bars)	

# HUSQVARNA<sup>®</sup> LIMITED TWO YEAR WARRANTY FOR 2005 TRANSPORTATION AND UTILITY VEHICLES

---

## 1. WARRANTY:

HUSQVARNA, INC., ("HUSQVARNA") hereby warrants to the Original Retail Purchaser that its new 2005 Model Transportation and Utility Vehicles purchased from HUSQVARNA or an authorized dealer shall be free from defects in material and workmanship under normal use and service as a transportation or utility vehicle for the periods stated below, subject to the provisions, limitations and exclusions contained in this limited warranty.

**LIMITED TWO YEAR / 2000 HOUR WARRANTY:** The engine assembly, unitized transaxle assembly (gasoline vehicle), motor, transaxle assembly (electric vehicle), main frame assembly, hydraulic dump kit, Custom Cab assembly and doors, and Driving Range Protective Enclosure are warranted with respect to parts and labor against defects in material and workmanship for a period of two years or 2000 hours of operation, whichever first occurs, from the date of purchase.

**LIMITED ONE YEAR / 1000 HOUR WARRANTY:** All remaining components of the vehicle not specified otherwise, the Portable Refreshment Center, and all other original equipment options and accessories supplied by HUSQVARNA are warranted with respect to parts and labor against defects in material and workmanship for a period of one year or 1000 hours of operation, whichever first occurs, from the date of purchase.

This limited warranty covers material, workmanship and repair labor cost as to those items specifically listed above for the periods specified. Such repair labor shall be performed only by HUSQVARNA, its authorized dealers, or a service agency approved by HUSQVARNA.

IF THE WARRANTY REGISTRATION FORM IS NOT COMPLETED AND RETURNED TO HUSQVARNA AT THE TIME OF THE ORIGINAL RETAIL SALE, PURCHASER MUST PROVIDE PROOF OF DATE OF PURCHASE WITH ANY WARRANTY CLAIM.

## 2. EXCLUSIONS:

Excluded from any HUSQVARNA warranty are all fuses, filters, decals (except safety decals), spark plugs, light bulbs, lubricants, trim pieces, seats, routine wear items such as the charger plug and receptacle, brake shoes, belts, brushes, bushings, engine mounts, mats and pads, maintenance adjustments, cosmetic deterioration, and items which deteriorate or fail due to exposure or ordinary wear and tear. Batteries, battery charger, onboard computer, and solid-state speed controller are covered under separate HUSQVARNA warranties. Also excluded from any HUSQVARNA warranty is damage to a vehicle or component resulting from a cause other than a defect including unreasonable or unintended strain or use, improper installation of accessories, installation of parts or accessories that are not original equipment, overloading, accident, alteration, abuse or neglect.

Transportation expenses for warranty services are also excluded from this warranty.

## 3. VOIDING OF WARRANTY:

THIS AND ANY OTHER WARRANTY SHALL BE VOID IF THE VEHICLE IS ABUSED OR USED IN AN UNINTENDED MANNER OR SHOWS INDICATIONS THAT IT HAS BEEN ALTERED IN ANY WAY, INCLUDING, BUT NOT LIMITED TO, MODIFICATION OF THE SPEED GOVERNOR, BRAKING SYSTEM, STEERING, TRANSAXLE, OR OTHER OPERATING SYSTEMS OF THE VEHICLE TO CAUSE IT TO PERFORM OUTSIDE HUSQVARNA SPECIFICATIONS. THE WARRANTY IS LIKEWISE VOID IF THE VEHICLE INVOLVED SHOWS INDICATIONS THAT REASONABLE OR NECESSARY MAINTENANCE AS OUTLINED IN THE OWNER'S MANUAL AND MAINTENANCE AND SERVICE MANUAL WAS NOT PERFORMED AT THE TIME AND IN THE MANNER SPECIFIED IN SUCH MANUALS.

## 4. SOLE REMEDY:

HUSQVARNA's liability under this limited warranty, or in any action whether based upon warranty, contract, negligence, strict product liability or otherwise, shall be the repair or replacement, at HUSQVARNA's option, of the vehicle or component thereof that HUSQVARNA deems to be defective. Replacement shall mean furnishing, during the applicable limited warranty period, a new vehicle or factory-reconditioned vehicle or component thereof that is identical or reasonably equivalent to the warranted product or component at no cost to the purchaser. Repair shall mean remedying a defect in the vehicle or component thereof at no cost to the purchaser during the applicable limited warranty period. If HUSQVARNA elects to repair the vehicle, it may provide factory-reconditioned parts or components. All parts and components replaced under warranty shall become the property of HUSQVARNA.

## 5. HOW TO MAKE A WARRANTY CLAIM:

To make a warranty claim under this limited warranty, you must present the vehicle or defective component to an authorized HUSQVARNA dealer.

**6. DISCLAIMER:**

THIS LIMITED WARRANTY IS EXCLUSIVE. HUSQVARNA MAKES NO OTHER WARRANTY OF ANY KIND, EXPRESSED OR IMPLIED. ANY IMPLIED WARRANTIES OF MERCHANTABILITY OR FITNESS FOR A PARTICULAR PURPOSE WHICH EXCEED THE OBLIGATIONS OR TIME LIMITS STATED IN THIS WARRANTY ARE HEREBY DISCLAIMED BY HUSQVARNA AND EXCLUDED FROM THIS WARRANTY. THE PURCHASER AND HUSQVARNA EXPRESSLY AGREE THAT THE REMEDY OF THE REPLACEMENT OR REPAIR OF THE DEFECTIVE VEHICLE OR COMPONENT THEREOF IS THE SOLE REMEDY OF THE PURCHASER. HUSQVARNA MAKES NO OTHER REPRESENTATION OR WARRANTY OF ANY KIND, AND NO REPRESENTATIVE, EMPLOYEE, OR DEALER OF HUSQVARNA HAS THE AUTHORITY TO MAKE OR IMPLY ANY REPRESENTATION, PROMISE OR AGREEMENT, WHICH IN ANY WAY VARIES THE TERMS OF THIS WARRANTY.

**7. NO CONSEQUENTIAL DAMAGES:**

IN NO EVENT SHALL HUSQVARNA BE LIABLE FOR ANY INCIDENTAL OR CONSEQUENTIAL DAMAGES INCLUDING, BUT NOT LIMITED TO, LOSS RELATED TO PROPERTY OTHER THAN THE VEHICLE, LOSS OF USE, LOSS OF TIME, INCONVENIENCE, OR ANY OTHER ECONOMIC LOSS.

Some states allow neither limitation on the duration of an implied warranty nor exclusions or limitation of incidental or consequential damages. Therefore, the above limitations or exclusions may not apply to you.

This warranty gives you specific legal rights, and you may also have other rights, which vary from state to state.

**8. INFORMATION:**

For further information contact WARRANTY SERVICES, HUSQVARNA FOREST & GARDEN, PRODUCT MARKETING MANAGER – AUTOMOWER, 7349 STATESVILLE ROAD, CHARLOTTE, NC 28269 OR CALL 1-800-448-7543.

**9. WARNING:**

Any modification or alteration of any vehicle beyond factory specifications, including those that affect the weight distribution, stability, or speed of the vehicle, can cause serious personal injury or death.

## TECHNICAL & CONSUMER INFORMATION (GASOLINE ENGINES)

---

### Carburetor Modification for High Altitude Operation

At high altitude, the standard carburetor air-fuel mixture will be too rich. Performance will decrease, and fuel consumption will increase. A very rich mixture will also foul the spark plug and cause hard starting. Operation at an altitude that differs from that at which this engine was certified, for extended periods of time, may increase emissions.

High altitude performance can be improved by specific modifications to the carburetor. If you always operate your engine at altitudes above 5,000 feet (1,500 meters), have your servicing dealer perform this carburetor modification. This engine, when operating at high altitude with the carburetor modifications for high altitude use, will meet each emission standard throughout its useful life.

Even with carburetor notification, engine horsepower will decrease about 3.5% for each 1,000-foot (300-meter) increase in altitude. The effect of altitude on horsepower will be greater than this if no carburetor modification is made.

**NOTE:** *When the carburetor has been modified for high altitude operation, the air-fuel mixture will be too lean for low altitude use. Operation at altitudes below 5,000 feet (1,500 meters) with a modified carburetor may cause the engine to overheat and result in serious engine damage. For use at low altitudes, have your servicing dealer return the carburetor to original factory specifications.*

### Oxygenated Fuels

Some conventional gasolines are being blended with alcohol or an ether compound. These gasolines are collectively referred to as oxygenated fuels.

To meet clean air standards, some areas of the United States and Canada use oxygenated fuels to help reduce emissions.

If you use an oxygenated fuel, be sure it is unleaded and meets the minimum octane rating requirement.

Before using an oxygenated fuel, try to confirm the fuel's contents. Some states/provinces require this information to be posted on the pump.

The following are the EPA approved percentages of oxygenates:

**ETHANOL:** (ethyl or grain alcohol) 10% by volume

You may use gasoline containing up to 10% ethanol by volume. Gasoline containing ethanol may be marketed under the name "Gasohol".

**MTBE:** (methyl tertiary butyl ether) 15% by volume

You may use gasoline containing up to 15% MTBE by volume.

**METHANOL:** (methyl or wood alcohol) 5% by volume

You may use gasoline containing up to 5% methanol by volume, as long as it also contains cosolvents and corrosion inhibitors to protect the fuel system. Gasoline containing more than 5% methanol by volume may cause starting and/or performance problems. It may also damage metal, rubber, and plastic parts of your fuel system.

If you notice any undesirable operating symptoms, try another service station, or switch to another brand of gasoline.

Fuel system damage or performance problems resulting from the use of an oxygenated fuel containing more than the percentages of oxygenates mentioned above are not covered under warranty.

## **Emission Control System Information**

### **Source of Emissions**

The combustion process produces carbon monoxide, oxides of nitrogen, and hydrocarbons. Control of hydrocarbons and oxides of nitrogen is very important because, under certain conditions, they react to form photochemical smog when subjected to sunlight. Carbon monoxide does not react in the same way, but it is toxic.

Honda utilizes lean carburetor settings and other systems to reduce the emissions of carbon monoxide, oxides of nitrogen and hydrocarbons.

### **The U.S. and California Clean Air Acts**

EPA and California regulations required all manufacturers to furnish written instructions describing the operation and maintenance of emission control systems.

The following instructions and procedures must be followed in order to keep the emissions from your Honda engine within the emissions standards.

### **Tampering and Altering**

Tampering with or altering the emission control system may increase emissions beyond the legal limit. Among those acts that constitute tampering are:

- Removal or alteration of any part of the intake, fuel or exhaust systems.
- Altering or defeating the governor linkage or speed-adjusting mechanism to cause the engine to operate outside its design parameters.

### **Problems That May Affect Emissions**

If you are aware of any of the following symptoms, have your engine inspected and repaired by your servicing dealer.

- Hard starting or stalling after starting.
- Rough idle.
- Misfiring or backfiring under load.
- After burning (backfiring).
- Black exhaust smoke or high fuel consumption.

### **Replacement Parts**

The emission control systems on your Honda engine were designed, built, and certified to conform with EPA and California emission regulations. We recommend replacement parts be purchased from Husqvarna, Inc.. These original-design replacement parts are manufactured to the same standards as the original parts, so you can be confident of their performance. The use of replacement parts that are not of the original design and quality may impair the effectiveness of your emission control system.

A manufacturer of an aftermarket part assumes the responsibility that the part will not adversely affect emission performance. The manufacturer or rebuilder of the part must certify that use of the part will not result in a failure of the engine to comply with emission regulations.

### **Maintenance**

Follow the Periodic Service Schedule in the owner's manual. Remember that this schedule is based on the assumption that your vehicle will be used for its designed purpose. Sustained high-load or high-temperature operation, or use in unusually wet or dusty conditions, will require more frequent service.

# CALIFORNIA EMISSION CONTROL WARRANTY STATEMENT

---

Your new Husqvarna, Inc. ("HUSQVARNA") vehicle engine complies with both the U.S. EPA and State of California emission regulations. Husqvarna provides the same emission warranty coverage for engines sold in all 50 states.

## **YOUR WARRANTY RIGHTS AND OBLIGATIONS:**

The California Air Resources Board ("CARB") and HUSQVARNA are pleased to explain the emission control system warranty on your 2005 vehicle engine. In California, new small off-road engines must be designed, built and equipped to meet the State's stringent anti-smog standards. HUSQVARNA must warrant the emission control system on the vehicle engine for the periods of time listed below provided there has been no abuse, neglect or improper maintenance of your small off-road engine.

Your emission control system may include parts such as the carburetor or fuel-injection system, the ignition system, and catalytic converter. Also included may be hoses, belts, connectors and other emission-related assemblies.

Where a warrantable condition exists, HUSQVARNA will repair your vehicle engine at no cost to you including diagnosis, parts and labor.

## **MANUFACTURER'S WARRANTY COVERAGE:**

The 1995 and later small off-road engines are warranted for two years. If any emission-related part on your engine is defective, the part will be repaired or replaced by HUSQVARNA.

## **OWNER'S WARRANTY RESPONSIBILITIES:**

- As the vehicle engine owner, you are responsible for the performance of the required maintenance listed in your owner's manual. HUSQVARNA recommends that you retain all receipts covering maintenance on your vehicle engine, but Husqvarna cannot deny warranty solely for the lack of receipts or for your failure to ensure the performance of all scheduled maintenance.

- As the vehicle engine owner, you should however be aware that HUSQVARNA may deny you warranty coverage if vehicle engine or a part has failed due to abuse, neglect, improper maintenance or unapproved modifications.

- You are responsible for presenting vehicle engine to a HUSQVARNA distribution center as soon as a problem exists. The warranty repairs should be completed in a reasonable amount of time, not to exceed 30 days.

If you have any questions regarding your warranty rights and responsibilities, you should contact WARRANTY SERVICES, HUSQVARNA FOREST & GARDEN, PRODUCT MARKETING MANAGER – AUTOMOWER, 7349 STATEVILLE ROAD, CHARLOTTE, NC 28269.

## **HUSQVARNA EXPLANATION OF EMISSION CONTROL WARRANTY:**

### **1. WARRANTY:**

HUSQVARNA vehicle engines manufactured after January 1, 1995 and sold in the State of California, and U.S. EPA certified engines manufactured on or after September 1, 1996 and sold in all of the United States, are covered by this warranty for a period of two years from the date of purchase.

### **2. COVERAGE:**

Warranty repairs will be made without charge for diagnosis, parts, or labor. Such repair labor shall be performed only by HUSQVARNA, its authorized dealers, or a service agency approved by HUSQVARNA. All defective parts replaced under this warranty become the property of HUSQVARNA. Normal maintenance items, such as spark plugs and filter, that are on the list of warranted parts (below) are warranted up to their first scheduled replacement

HUSQVARNA is also liable for damages to other engine components caused by a failure of any warranted part during the warranty period.

Only HUSQVARNA approved replacement parts may be used in the performance of any warranty repairs and must be provided without charge to the owner. The use of replacement parts not equivalent to the original parts may impair the effectiveness of the engine emission control system. If such a replacement part is used in the repair or maintenance of the engine, and an authorized HUSQVARNA dealer determines it is defective or causes a failure of a warranted, part, your claim for repair of the engine may be denied. If the part in question is not related to the reason the engine required repair, the claim will not be denied.

\* Covered up to the first required replacement only. **See the Periodic Service Schedule in the owner's manual.**

Emission-related parts will vary between vehicles; therefore, certain vehicles may not include all of the listed parts or may include equivalent parts.

### **3. EXCLUSIONS:**

Excluded from this warranty is damage to a vehicle or component resulting from a cause other than a defect including unreasonable or unintended strain or use, improper installation of accessories, installation of parts or accessories that are not original equipment, overloading, accident, alteration, abuse or neglect. This warranty covers only those failures resulting from defects in material or workmanship.

Transportation expenses for warranty services are also excluded from this warranty.

### **4. VOIDING OF WARRANTY:**

THIS AND ANY OTHER WARRANTY SHALL BE VOID IF THE VEHICLE IS ABUSED OR USED IN AN UNINTENDED MANNER OR SHOWS INDICATIONS THAT IT HAS BEEN ALTERED IN ANY WAY, INCLUDING, BUT NOT LIMITED TO, MODIFICATION OF THE SPEED GOVERNOR, BRAKING SYSTEM, STEERING, TRANSAXLE, OR OTHER OPERATING SYSTEMS OF THE VEHICLE TO CAUSE IT TO PERFORM OUTSIDE HUSQVARNA SPECIFICATIONS. THE WARRANTY IS LIKEWISE VOID IF THE VEHICLE INVOLVED SHOWS INDICATIONS THAT REASONABLE OR NECESSARY MAINTENANCE AS OUTLINED IN THE OWNER'S MANUAL AND MAINTENANCE AND SERVICE MANUAL WAS NOT PERFORMED AT THE TIME AND IN THE MANNER SPECIFIED IN SUCH MANUALS.

### **5. NO CONSEQUENTIAL DAMAGES:**

In no event shall Husqvarna be liable for any incidental or consequential damages including, but not limited to, loss related to property other than the vehicle, loss of use, loss of time, inconvenience, or any other economic loss. This warranty is applicable only where the California or U.S. EPA emission control system warranty regulation is in effect.

### **6. HOW TO MAKE A WARRANTY CLAIM:**

To make a warranty claim under this limited warranty, you must present the vehicle or defective component to an authorized HUSQVARNA dealer or send the defective component, freight prepaid, to to WARRANTY SERVICES, HUSQVARNA, INC., Husqvarna FOREST & GARDEN, PRODUCT MARKETING MANAGER – AUTOMOWER, 7349 STATESVILLE ROAD, CHARLOTTE, NC 28269.

IF THE WARRANTY REGISTRATION FORM IS NOT COMPLETED AND RETURNED TO HUSQVARNA AT THE TIME OF THE ORIGINAL RETAIL SALE, PURCHASER MUST PROVIDE PROOF OF DATE OF PURCHASE WITH ANY WARRANTY CLAIM.

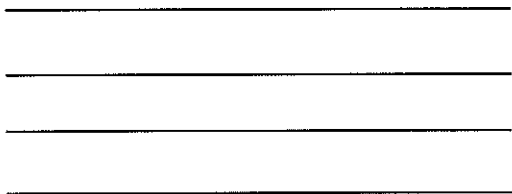

**NOTICE**

**PLEASE COMPLETE  
ATTACHED WARRANTY  
REGISTRATION CARD**



**Husqvarna Forest & Garden Co.**  
Attn.: Warranty Administration  
7349 Statesville Road  
Charlotte, NC 28269  
USA



**HUV VEHICLE  
LIMITED WARRANTY REGISTRATION**

In order to register this purchase, and protect the Limited Warranty, it is important that you complete the information below and return this card to Husqvarna Forest & Garden Co.

Purchased From \_\_\_\_\_

Owner's Name \_\_\_\_\_

Date of Delivery \_\_\_\_ / \_\_\_\_ / \_\_\_\_  
DD / MM / YEAR

Address \_\_\_\_\_

Serial Numbers

City \_\_\_\_\_ State/Province \_\_\_\_\_

1. \_\_\_\_\_

Zip Code \_\_\_\_\_

2. \_\_\_\_\_

Country \_\_\_\_\_

3. \_\_\_\_\_

Phone Number 011 - \_\_\_\_ - \_\_\_\_\_

4. \_\_\_\_\_

5. \_\_\_\_\_

I have read and fully understand the vehicle owner's manual.

\_\_\_\_\_  
Signature



Publication Part Number 603 00 00-14  
Edition Code 0904A00000

**Husqvarna Forest and Garden**  
7349 Statesville Rd.  
Charlotte, NC 28269  
USA  
[www.usa.husqvarna.com/huv](http://www.usa.husqvarna.com/huv)