

LUMBERJACK TOOLS

made in usa

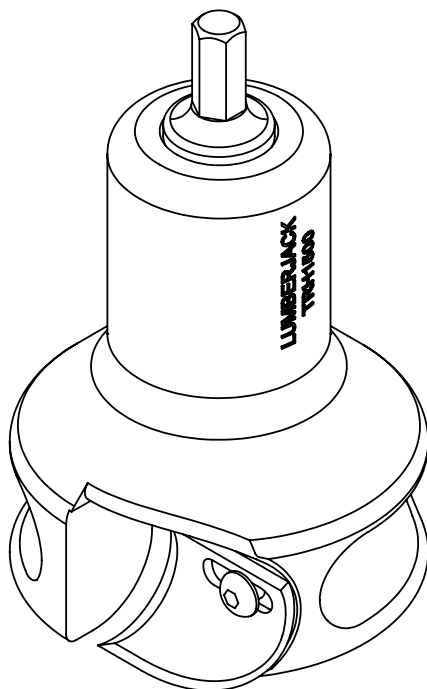
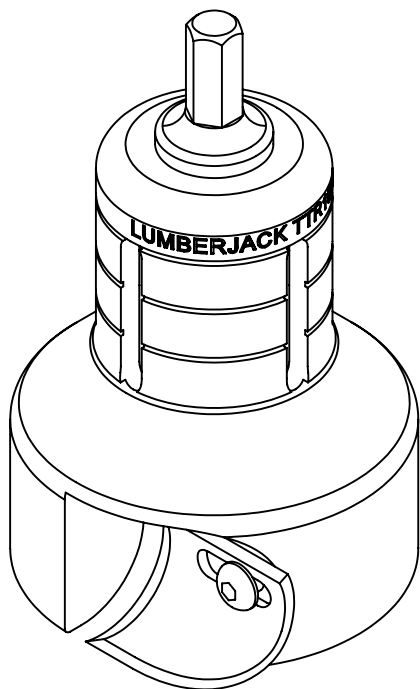

USER MANUAL
PRO & HOME SERIES
(Radius Shoulder Profile)
Dual Blade Tenon Cutters

Lumberjack Tools Inc.
PO Box 730
Chippewa Falls, WI 54729
www.lumberjacktools.com
Email: info@lumberjacktools.com
Phone: 715-720-4719
Rev: 2/17



MODELS:
Pro Series - TTR0500
Pro Series - TTR0750
Pro Series - TTR1000
Pro Series - TTR1500
Pro Series - TTR2000
Home Series - TRH1000
Home Series - TRH1500
Home Series - TRH2000

About Your Product

Thank you for purchasing our Dual Blade - Radius Shoulder Tenon Cutter! Lumberjack engineers, along with our craftsmen, have designed the safest, easiest-to-use tenon cutters on the market. By combining old world skills with 3D CAD modeling and CNC manufacturing, we have created the ideal tenon cutter: straight tenons, smooth finish, precision operation, and long life.

Dual-bladed tenon tools will cut a tenon in half the time of a single-bladed tool. Wear is reduced by putting force of cutting across two blades instead of one. The blades are stamped, heat treated and precision ground to provide years of service if properly maintained. The Pro tools are machined from a solid aluminum billet and the Home tools are made of die-cast aluminum.



Our lifetime guarantee covers the tool body and shank. The blades are covered for 90 days from the date of purchase for breakage under normal working conditions. Blades will dull faster cutting hardwoods vs softwoods (peeled or unpeeled). Soil and other abrasive substances will reduce blade life and is not covered under this warranty. When making a claim, you must show proof of purchase from an authorized distributor. This is valid only to the original buyer, and not for tools sold secondhand, used, or sold "as is" to a second party.

What Voids Warranty

In order to keep our lifetime and 90 day warranty you must **AVOID** the following actions:

- Operating the tool in a drill press or lathe (or any system other than a hand-held drill)
- Running the tool into a nail or foreign object
- Altering or misusing the tool

SAFETY

Before beginning any project, carefully read and follow ALL safety and operational instructions for any tools or devices you will be using. Failure to do so may cause physical harm to yourself or those around you. If you feel uncomfortable using our tenon cutters or any other tool, STOP immediately. Lumberjack Tools assumes no responsibility for injury caused to the operator, bystander, or tools used in conjunction with the use or misuse of our tenon cutters.



NEVER OPERATE POWER TOOLS UNDER THE INFLUENCE OF DRUGS, ALCOHOL, OR ANY MEDICATIONS



ALWAYS WEAR SAFETY GLASSES, DUST MASK, AND ANY OTHER PERSONAL PROTECTION ITEMS AS NEEDED



NEVER WEAR LOOSE ITEMS THAT COULD BE CAUGHT IN MOVING PARTS. SECURE LOOSE OR LONG HAIR AWAY FROM AREA



WE STRONGLY RECOMMEND A SINGLE-SPEED, GEAR DRIVEN DRILL WITH RPMS OF 500 OR LESS. EXCEEDING THESE RPMS MAY RESULT IN DAMAGE TO THE TOOL



ALWAYS DISCONNECT POWER AND ALLOW DRILL TO COME TO A COMPLETE STOP BEFORE INSTALLING, REMOVING, OR ADJUSTING THE TOOL



NEVER APPLY BENDING FORCE (SIDE LOADING) TO THE TOOL. SIDE LOADING COULD CAUSE THE SHANK TO FAIL, OR MAY RESULT IN BLADE DAMAGE



ALWAYS SECURE THE LOG IN A VISE OR CLAMP PRIOR TO STARTING YOUR DRILL. FAILURE TO DO SO MAY RESULT IN INJURY



ALWAYS HANDLE THE BLADES WITH EXTREME CARE! FAILURE TO DO SO MAY RESULT IN SERIOUS INJURY



NEVER PUT HANDS OR ANY BODY PART INSIDE THE TOOL WHILE THE BLADES ARE ATTACHED! DOING SO MAY CAUSE SERIOUS INJURY



WHEN EXCESSIVE FORCE IS REQUIRED TO CUT, RE-SHARPEN OR REPLACE THE BLADES. A SHARP TOOL IS A SAFE TOOL!

Pro Series ONLY

Quick Stop Installation

1

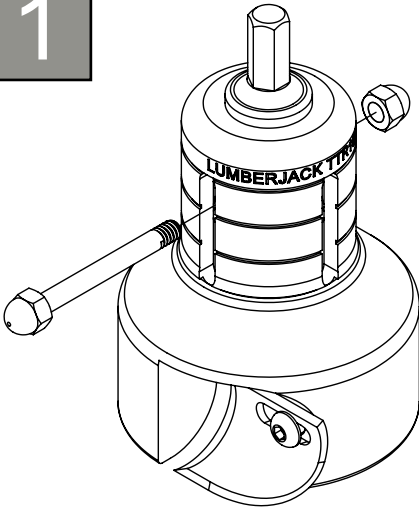

- Install the quick stop pin through the tool body
- Secure with the supplied acorn nut

2

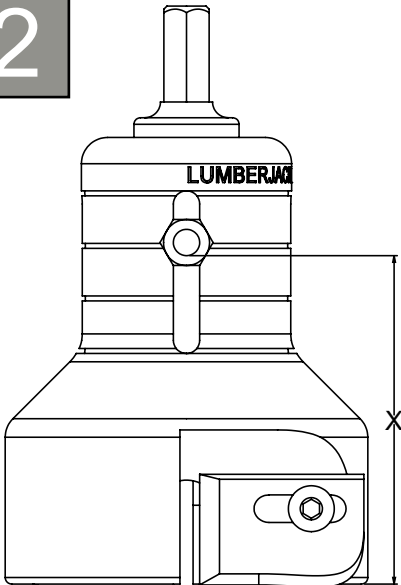

- The length of the tenon is determined by measuring from the face of the tool to the **bottom** of the Quick Stop Pin and subtracting $3/4$ "
- In the image to the left, dimension " X " - $3/4$ " = approximate length of the tenon

Setting the Blades

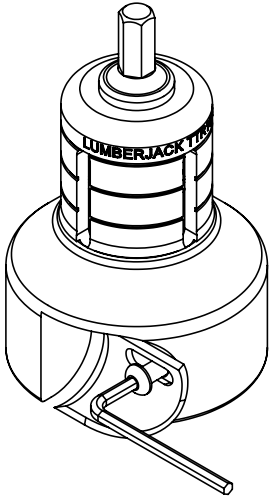

- Install and secure the blades with the Button Head Cap Screws
- Take care to keep the blade offset of both blades equal (see below)

Max Log Capacity	
Series	Max Log Dia.
TTR0500	1.75"
TTR0750	2.50"
TTR1000	3.00"
TTR1500	3.50"
TTR2000	4.00"
TRH1000	3.00"
TRH1500	3.50"
TRH2000	4.00"

TIP

- The cardboard box that the tool comes in is slightly thicker than 1/8"
- Remove a piece of box to use as a quick spacer for blade setting

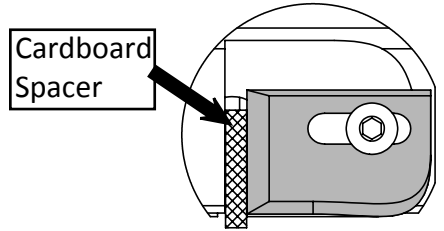

Blade Offset

<p>1/8"</p> <p>Correct (smaller tenon)</p>	<p>1/4"</p> <p>Correct (larger tenon)</p>	<p>WRONG</p>
---	--	---------------------

The tenon diameter is variable based on the blade offset. Smaller offset = smaller tenon, larger offset = larger tenon. 3/16" blade offset is a good place to start, but you will want to test tenon fit in holes to achieve the correct offset (we recommend writing the results down). **DO NOT** set the blades beyond 5/16" or the blade edge will not contact the log and will not cut.



Determine tenon length before cutting

- The key is to have a gap between the end of the tenon and bottom of the mortise hole
- This can be done by making the tenon $1/8''$ to $1/4''$ shorter than the mortise hole is deep

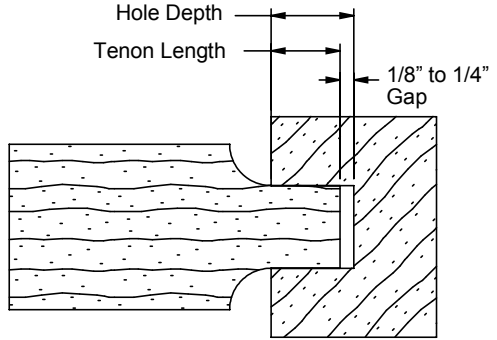

Calculated Tenon Length

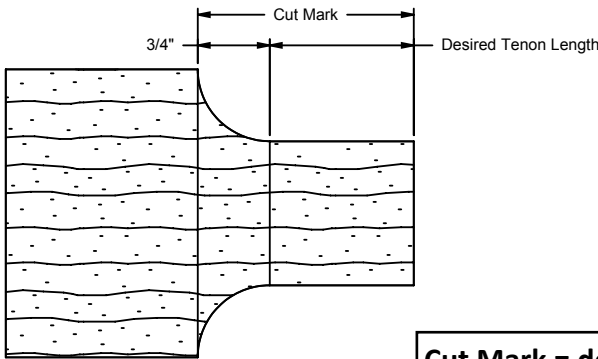

Gather the following information and use the calculation provided below:

- Desired tenon length

$$\text{Cut Mark} = \text{desired tenon length} + 3/4''$$

Simple Tenon Length

- Tenon length can be controlled without having the Industrial Series or Quick Stop Pins
- Cut off a piece of tenon to use as a plug to stop cutting at a set length

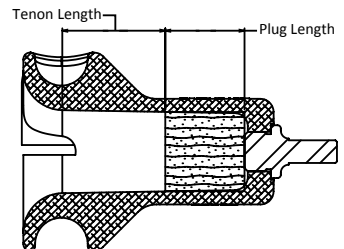
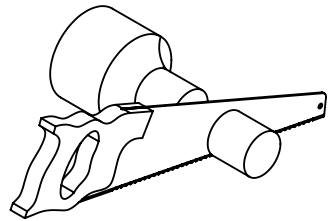

Series	Tenon Length
TRH1000	$2 \frac{1}{2}''$ – Plug Length
TRH1500	$3 \frac{1}{2}''$ – Plug Length
TRH2000	$4 \frac{1}{2}''$ – Plug Length

Cutting Tenons



WARNING: If the log comes loose or unclamped while cutting the tenon, **DO NOT** drop the drill or try to grab the log! Stop the drill and remove it from the end of the log. Re-secure the log, and resume

1

- Obtain the log you want to tenon
- Cut it to length and make sure the ends are flat. If the ends are not even/flat, the tenon will be crooked

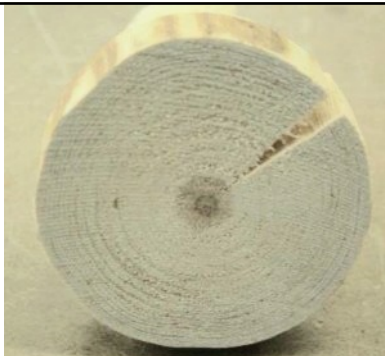

2

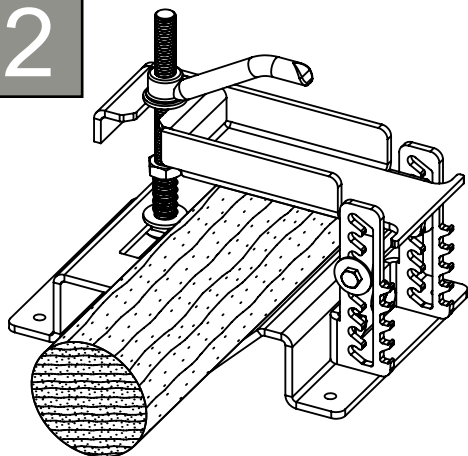

- Secure the log in a vise, clamp, or fixture with a “V” shaped notch
- The **Log Lock** (LL1545) is a safe, easy, economical way to clamp logs, and is available on our website

3

- If the log diameter is larger than the tool can accept, taper the end with a draw knife



Cutting Tenons (cont.)



ALWAYS unplug the drill before adjusting the blades or adjusting the chuck

4

- Carefully install the tenon cutter into an unplugged 1/2" drill, and tighten it firmly. Use the tee handle to tighten the chuck
- Square up to the log so that the cutter is flush against the flat face of the log
- Apply body pressure by leaning into the drill
- Pull the trigger to cut the tenon
- Wait until the drill comes to a stop before removing the cutter from the log

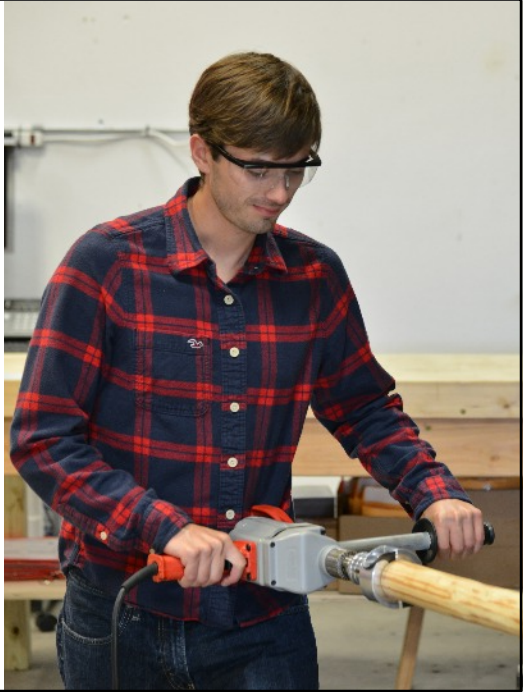

- Make sure the tool is square against the end of the log before cutting
- If the tool is held at an angle the tenon will be cut angled

4.5

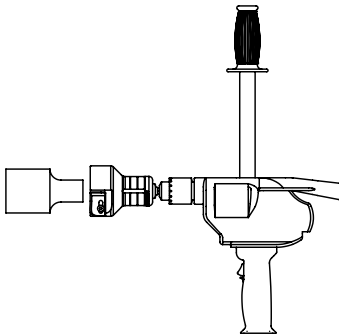

CORRECT
Drill in-line with log

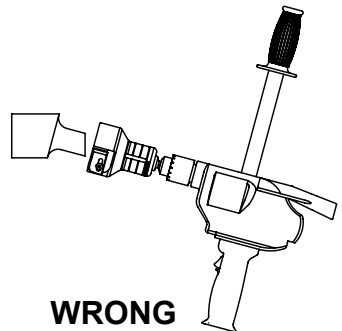

WRONG
Drill not in-line with log (crooked)

Drilling Holes (Mortise)

1

- Measure and mark the locations of all holes before drilling
- Place the center of the bit on the desired hole location
- Take care to hold the drill perpendicular to the log
- Use a forstner bit (or spade bit) to drill the hole



2

- Drill mortise between $\frac{1}{3}$ and $\frac{1}{2}$ of the log diameter
- Do not drill more than $\frac{1}{2}$ of the log diameter unless a specific project calls for a deeper mortise

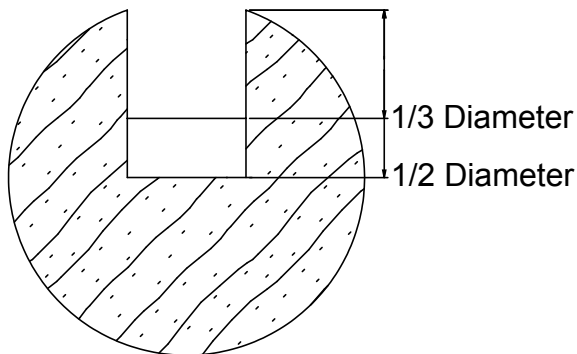

Additional Tips

- It takes time to master using these tools
- Make a plan of what you want to build before you begin
- Have a list of all tools and materials you will need
- Do not over complicate your first few projects
- Practice reading the natural twists and defects in the wood
- Practice cutting tenons and using the tools on scrap material

Maintenance

● Body

- Cleaning
 - Keep the tenon cutter body clear of sap and other build-up
 - Always remove the blades before cleaning
 - Clean the tool with a solvent (such as mineral spirits)



**WARNING: ALWAYS HANDLE THE BLADES WITH EXTREME CARE!
FAILURE TO DO SO MAY RESULT IN SERIOUS INJURY**

● Blades

- Care
 - Always wipe blades with a thin film of oil at the end of the day to help prevent oxidation
- Cleaning
 - Clean the blades with a solvent (such as mineral spirits) and **immediately** apply a thin film of oil to prevent oxidation
- Sharpening
 - Use a sharpening stone or file to re-sharpen the blades, then clean the blades and apply a thin film of oil

● Shank

- Replacement
 - If your shank breaks, we offer replacement shanks (see first page for contact information)
 - Turn the shank counter-clockwise to remove
 - Turn the shank clockwise to install

TASK	EACH USE	MONTHLY
Clean blade pockets	X	
Clean cutter bore	X	
Clean blades	X	
Inspect blades	X	
Oil blades	X	
Oil shank & screws		X

Troubleshooting

PROBLEM	CAUSE	SOLUTION
• Tool Skips off to one side or bounces around	• Log is larger than tool will accept	• Taper down the end of the log with a draw knife
	• Not enough pressure is being applied	• Lean into drill with body
• Not cutting log	• Log is larger than tool will accept	• Taper down the end of the log with a draw knife
	• Blades are slid too far back	• Position blades so they are back no further than 5/16"
	• Blades are dull • Not applying enough pressure	• Sharpen blades • Purchase new blades • Lean into drill with body
• Takes too much of a "bite"	• Aggressive cutting from dual blades	• Remove one blade or "shim" blade up to .020"
• Crooked Joint	• Holding drill crooked while cutting	• Position the drill square against the log before cutting
• Drill stops or cuts on small diameter logs but not larger ones	• Using a variable speed drill	• Make sure you are using a single-speed drill with low RPMs
	• Using a non-Milwaukee brand drill	• We recommend purchasing a Milwaukee brand hole hog drill
• Spiral grooves on the tenon joint	• Lateral wobbling of the drill	• Hold the drill as steady as you can while cutting
	• Removing the cutter while drill is still spinning	• DO NOT remove the cutter until the drill has come to a complete stop

Unexpected Occurrences

Engineers and Quality Control staff at Lumberjack Tools have provided you with one of the easiest to use and safest tenon cutters on the market. However, there is always the unexpected chance of failure.

- Please contact our customer support for a replacement if a failure ever occurs to the tool body, shank or blades

Thank you again for purchasing our tools!

BLADES SLIPPING?

IF YOU ENCOUNTER AN ISSUE WITH THE BLADES
SLIPPING ON YOUR RED HOME SERIES TOOL, IT
MAY BE DUE TO THE CLEAR COAT ON THE PAINT IN
THE BLADE POCKET

TO RESOLVE THIS ISSUE, FOLLOW THE STEPS BELOW



- 1. REMOVE THE BLADES (CAUTION - SHARP)**
- 2. LOCATE THE BLADE POCKET**
- 3. LIGHTLY SAND OFF THE CLEAR COAT WITH 150 GRIT SANDPAPER**
- 4. VERIFY THAT THE CLEAR COAT HAS A 'ROUGHED UP' SURFACE**
 - THIS ALLOWS THE BLADE TO HAVE A BETTER GRIP WHILE CUTTING**
- 5. REPLACE THE BLADES & TRY CUTTING AGAIN TO ENSURE IT FUNCTIONS PROPERLY**
- 6. REPEAT STEP 3 IF NECESSARY**

STILL EXPERIENCING ISSUES? GIVE US A CALL AT 715-720-4719