

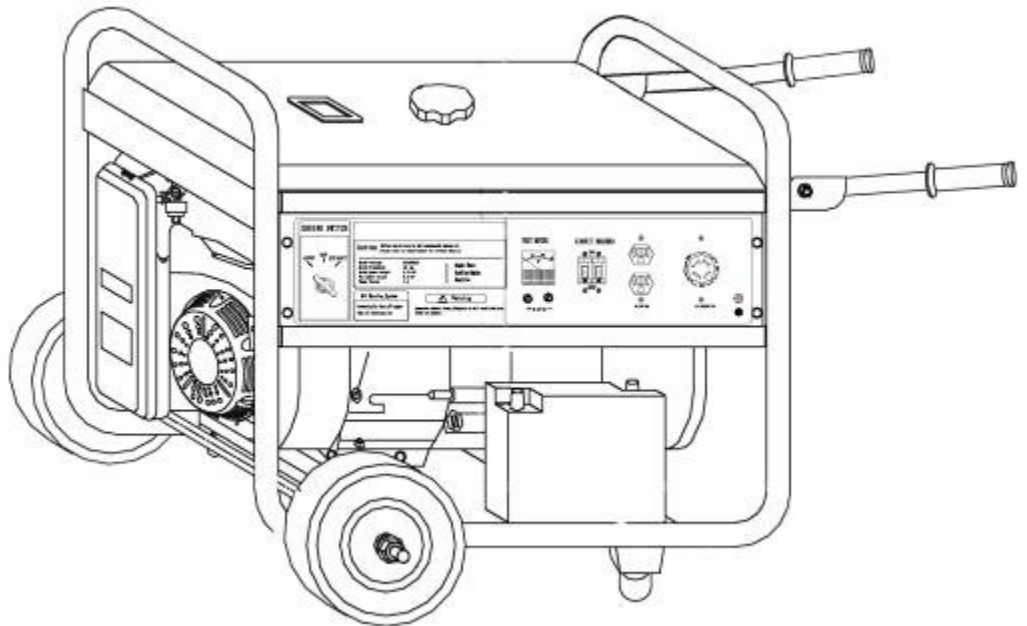

# Gasoline Powered Generator Owner's Manual

- XP4400**
- XP4400E**
- XP6500E**
- XP8500E**



**Imperial Industrial Supply Customer Service**  
 davev@directvantage.com  
 or call 1-800-382-8273 (#239) Monday –Friday 6am to 7pm

**Product Support** (Product: information, application, service info & warranty questions)  
 or call 1-800-382-8273 (#239) Monday –Friday 6am to 7pm

This manual provides information regarding the operation and maintenance of these products.  
 We have made every effort to ensure the accuracy of the information in this manual.  
 We reserve the right to change this product at any time without prior notice.

## **FEATURES**

- Powerful Enough to Run Essential Appliances***
- During Power Outages***
- 120 and 240 Volt AC Outputs***
- 12V DC Output for Automotive Battery Charging***
- Low Oil Automatic Shutoff***
- Circuit Breaker for Overload Protection***
- Max Fuel Tank Capacity***
- Handles and Wheels For Extra Mobility***
- Meets EPA and CARB emissions standards***

# TABLE OF CONTENTS

GENERAL SAFETY PROCEDURES.....	1
PACKAGE CONTENTS.....	4
GENERATOR COMPONENTS.....	5
PREPARING THE GENERATOR FOR USE.....	6
Using the Generator for the First Time.....	6
Step 1-Add Oil.....	6
Step 2- Add Gasoline.....	7
Step 3- Ground the Generator.....	7
Subsequent Use of the Generator.....	8
Step 1- Check the Oil.....	8
Step 2-- Check the Gas Level.....	8
Step 3- Ground the Generator.....	8
STARTING THE GENERATOR.....	9
USING THE GENERATOR.....	10
AC Usage.....	10
DC Usage.....	12
STOPPING THE GENERATOR.....	13
MAINTENANCE / CARE.....	13
Cleaning the Generator.....	13
Checking the Oil.....	14
Changing/Adding Oil.....	14
Air Cleaner Maintenance.....	15
Fuel Filter Cup Cleaning.....	16
Spark Plug Maintenance.....	16
Emptying the Gas Tank.....	17
STORAGE / TRANSPORT PROCEDURES.....	17
SPECIFICATIONS.....	17
TROUBLESHOOTING .....	18
WIRING DIAGRAM .....	20
EXPLODED VIEW AND PARTS LIST.....	21

## **Notice Regarding Emissions**

Engines that are certified to comply with California and U.S. EPA emission regulations for

SORE (Small Off Road Equipment), are certified to operate on regular unleaded gasoline, and may include the following emission control systems: (EM) Engine Modifications and (TWC) Three-Way Catalyst (if so equipped).

## GENERAL SAFETY PROCEDURES

Please familiarize yourself with the following safety symbols and words:

The safety alert symbol  is used with one of the safety words (**DANGER**, **CAUTION**, or **WARNING**) to alert you to hazards. Please pay attention to these hazard notices both in this manual and on the generator.

**DANGER:** Indicates a hazard that will result in serious injury or death if instructions are not followed.

**WARNING:** Indicates a strong possibility of causing serious injury or death if instructions are not followed.

**CAUTION:** Indicates a possibility of personal injury or equipment damage if instructions are not followed.

---

 **DANGER:** This generator produces poisonous carbon monoxide gas when running. This gas is both odorless and colorless. Even if you do not see or smell gas, carbon monoxide may still be present. Breathing this poison can lead to headaches, dizziness, drowsiness, and eventually death.

·Use outdoors **ONLY** in non-confined areas.

·Keep several feet of clearance on all sides to allow proper ventilation of the generator.

 **WARNING:** The exhaust from this product contains chemicals known to the State of California to cause cancer, birth defects, or other reproductive harm.

**⚠ WARNING: This generator produces powerful voltage, which can result in electrocution.**

- ALWAYS ground the generator before using it (see the "Grounding the Generator" portion of the "PREPARING THE GENERATOR FOR USE" section).
- Generator should only be plugged into electrical devices, either directly or with an extension cord. NEVER connect to a building electrical system without a qualified electrician. Such connections must comply with local electrical laws and codes. Failure to comply can create a backed, which may result in serious injury or death to utility workers.
- Use a ground fault circuit interrupter (GFCI) in highly conductive areas such as metal decking or steel work. GFCIS are available in-line with some extension cords.
- Do not use in rainy or wet conditions.
- Do not touch bare wires or receptacles (outlets).
- Do not allow children or non-qualified persons to operate.

**⚠ WARNING: This generator may emit highly flammable and explosive gasoline vapors, which can cause severe burns or even death. A nearby open flame can lead to explosion even if not directly in contact with gas.**

- Do not operate near open flame.
- Do not smoke near generator.
- Always operate on a firm, level surface.
- Always turn generator off before refueling. Allow generator to cool for at least 2 minutes before removing fuel cap. Loosen cap slowly to relieve pressure in tank.
- Do not overfill gas tank. Gas may expand during operation. Do not fill to the top of the tank.
- Always check for spilled gas before operating.
- Empty gasoline tank before storing or transporting the generator.
- Before transporting, turn fuel valve to off and disconnect spark plug.

**⚠ WARNING: This generator produces heat when running. Temperatures near exhaust can exceed 150°F (65°C).**

- Do not touch hot surfaces. Pay attention to warning labels on the generator denoting hot parts of the machine.
- Allow generator to cool several minutes after use before touching engine or areas which heat during use.

**CAUTION: Misuse of this generator can damage it or shorten its life.**

- Use generator only for its intended purposes.
- Operate only on dry, level surfaces.
- Allow generator to run for several minutes before connecting electrical devices.
- Shut off and disconnect any malfunctioning devices from generator.
- Do not exceed the Wattage capacity of the generator by plugging in more electrical devices than the unit can handle (see "PRECAUTIONS-OVERLOADING THE GENERATOR").
- Do not turn on electrical devices until after they are connected to the generator.
- Turn off all connected electrical devices before stopping the generator.

In addition to the above safety notices, please familiarize yourself with the safety and hazard markings on the generator.

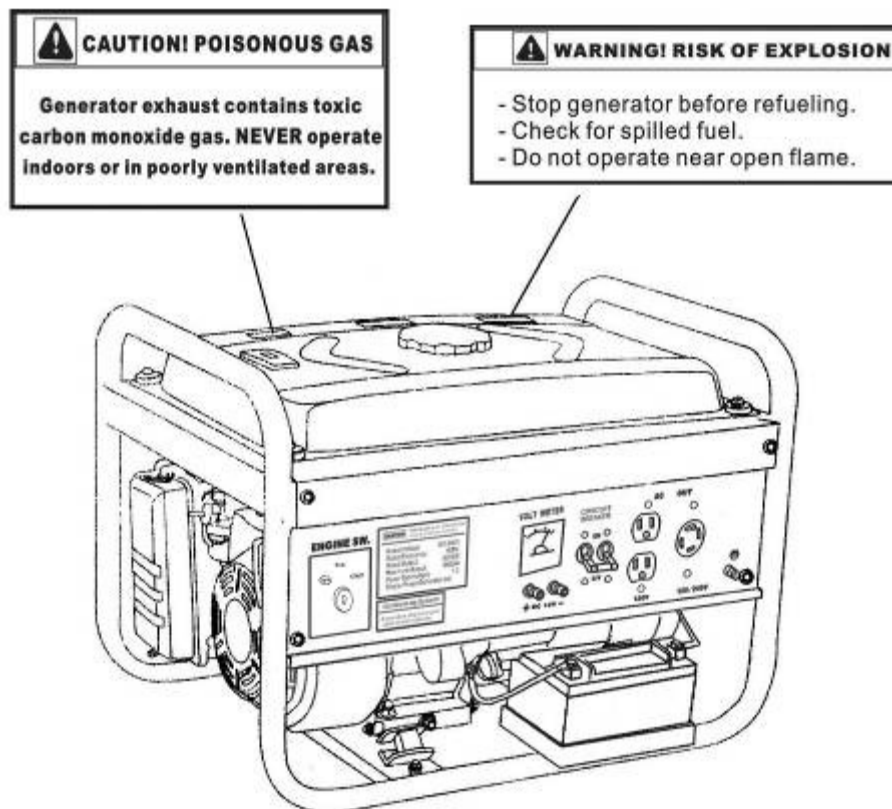

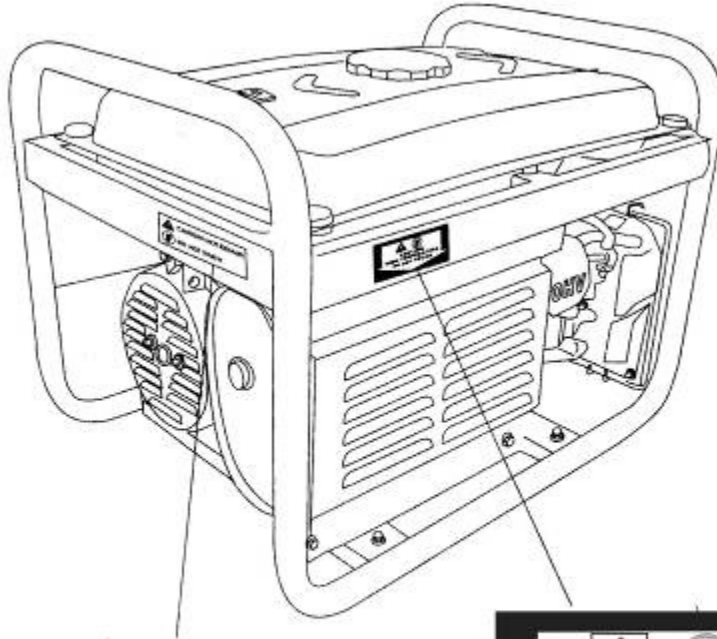

## PACKAGE CONTENTS

Your generator comes with the items listed below. Please check to see that all of the following items may be included with your generator, depending on your generator model.



Screw driver



Spanner

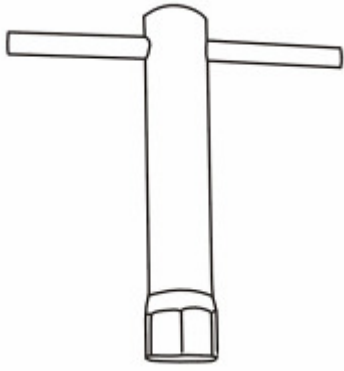

Spark plug wrench

## **GENERATOR COMPONENTS**

Please familiarize yourself with the locations and functions of the various components and controls of your generator.

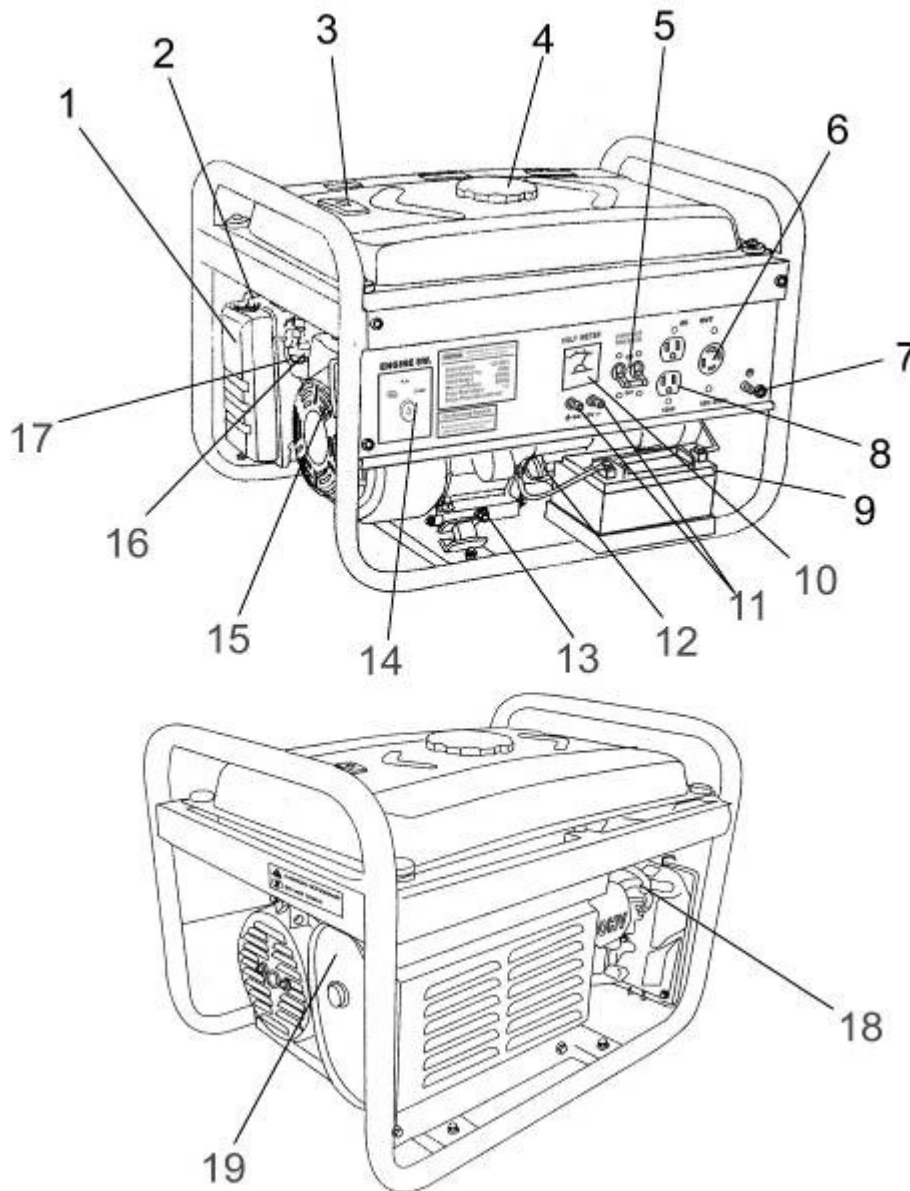

(1) **Air cleaner-** a removable, cleanable, sponge-like element that limits the amount of dirt pulled into the engine.

(2) **Choke lever-** Adjusts the amount of air let into the engine.

(3) **Fuel Gauge-** Indicates the amount of fuel in the tank.

(4) **Fuel Cap-** Access to the fuel tank for adding fuel.

(5) **Circuit Breaker-** Reset switch that protects the generator from electrical overload.

(6) **120/ 240 Volt AC Receptacle-** Use to connect electrical devices that run 120 and/or 240 Volt, 60Hz, single phase, AC current (NEMA L14-30).

(7) **Ground Terminal-** Connect grounding wires here to properly ground unit.

(8) **120 Volt AC Receptacle-** Use to connect electrical devices that run 120 Volt, 60 Hz, single phase, AC current (2×duplex GFCI).

(9) **12V DC of batteries.**

(10) **Volt Meter-** Provides reading of voltage output.

(11) **12V DC Receptacle-** Use for charging 12 Volt automotive-type batteries only.

(12) **Oil Filler Cap**- Use to Add oil or checking the oil.

(13) **Oil Fill and Dipstick**- Location for checking and filling engine oil.

(14) **Engine Switch**- Used to start/stop engine.

(15) **Recoil Starter**- Pull-cord for starting engine.

(16) **Fuel Filter Cup**- Traps dirt and water from fuel before it enters the engine.

(17) **Fuel valve**- Allows fuel to enter engine.

(18) **Spark plug**- Provides proper engine ignition.

(19) **Muffler**- Reduces engine noise.

## PREPARING THE GENERATOR FOR USE

### Using the Generator for the First Time

If you are using the generator for the first time, there are a few steps you must take to prepare it for operation.

#### **Step 1- Add oil**

The generator requires engine oil to operate properly. The generator, when new from the package, contains no oil in the crankcase. You must add the proper amount of oil before operating the generator for the first time. This amount, which is equal to the oil capacity of the engine crankcase, can be found on the chart in figure 1. When filling the engine with oil in the future, please refer to this chart.

Model number	XP4400	XP4400E	XP6500E	XP8500E
Engine oil capacity	20 fluid oz.	20 fluid oz.	37 fluid oz.	37 fluid oz.

Figure 1- Generator Oil Capacity

#### **CAUTION:**

· Do not apply engine oil with additives or 2-stroke gasoline engine oil, as they haven't enough lubrication, which may shorten the engine's service life.

· **Engine oil recommended: SAE 10W-30.**

As viscosity varies with regions and temperatures, so the lubricant has to be selected in accordance with our recommendation.

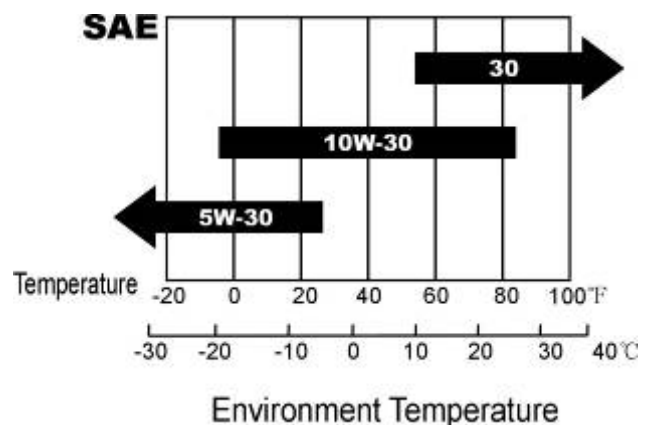

To add oil, follow these steps:

1. Make sure the generator is on a level surface.
2. Unscrew the oil filler/dipstick cap from the engine as shown in figure 2.
3. Using a funnel, add the appropriate amount of oil, as found in figure 1, into the crankcase.

You will know the crankcase is full when the oil level has reached the lower lip of the

opening you have just poured the oil into (see figure 3).

4. Replace oil filler cap.

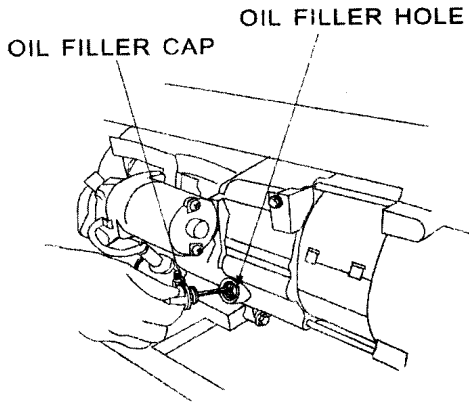

Figure 2- Unscrewing the oil cap



Figure 3 - Adding oil

## Step 2- Add Gasoline

**⚠ WARNING:** Gasoline and gas fumes are highly flammable.

- Do not fill tank near an open flame.
- Do not overfill. Always check for fuel spills.

To ensure that the generator runs smoothly use only FRESH, UNLEADED GAS WITH AN OCTANE RATING OF 87 OR HIGHER. To add gasoline:

1. Make sure the generator is on a level surface.
2. Unscrew gas cap and set aside (NOTE: the gas cap may be tight and hard to unscrew).
3. Slowly add unleaded gasoline to the fuel tank. Be careful not to overfill. Please refer to the chart in figure 4 to find the gas capacity of your generator model. The fuel gauge on the top of the generator indicates how much gasoline is in the generator gas tank.  
NOTE: Gas can expand. Do not fill the gas tank to the very top.
4. Replace fuel cap and wipe up any spilled gasoline with a dry cloth.

IMPORTANT:

- Never use an oil/gasoline mixture.
- Never use old gas.
- Avoid getting dirt or water in the fuel tank.
- Gas can age in the tank and make it hard to start up the generator in the future.

Never store generator for extended periods of time with fuel in the tank.

Model number	XP4400	XP4400E	XP6500E	XP8500E
Gas tank capacity	15L(3.96 us. gallons)		25L(6.6 us. gallons)	

Figure 4 - Gas Tank Capacity

### **Step 3- Ground the Generator**

**⚠ WARNING: Failure to properly ground the generator can result in electrocution.**

Ground the generator by tightening the grounding nut against a grounding wire (see figure 5). A generally acceptable grounding wire is a No. 12 AWG (American Wire Gauge) stranded copper wire. This grounding wire should be connected at the other end to a copper or brass-grounding rod that is driven into the end.

Grounding codes can vary by location. Please contact a local electrician to check the grounding regulations for your area.

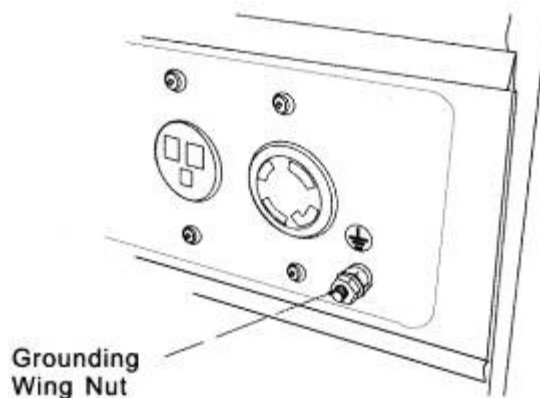

**Figure 5 – Attaching the Grounding Wire to the Generator**

#### **Subsequent Use of the Generator**

If this is not your first time using the generator there are still steps you should take to prepare it for operation.

**IMPORTANT: At this point you should be familiar with the procedures described in the first portion of this section entitled "Using the Generator for the First Time." If you have not yet read this section, go back and read it now.**

#### **Step 1- Check the oil**

The generator is equipped with an automatic shutoff to protect it from damage due to low oil. Nonetheless, you should check the oil level of the engine before each use to ensure that the engine crankcase has a sufficient amount. To check the oil level:

1. Make sure the generator is on a level surface.
2. Unscrew the oil filler/dipstick cap.
3. With a dry cloth, wipe the oil off of the stick on the inside of the cap.
4. Insert the dipstick as if you were replacing the cap and then remove again. There should now be oil on the stick. If there is no oil on the stick, or oil only at the very end of the stick, you should add oil until the engine crankcase is filled (see "Adding Oil" portion of the "Maintenance" section).
5. Be sure to replace cap when finished checking oil.

**NOTE:** The oil capacity for your generator can be found in the "Specifications" section of this manual.

#### **Step 2 - Check the Gas Level**

Before starting the generator, check to see that there is sufficient gasoline in the gas tank. The fuel gauge on top of the generator will indicate the gas level in the tank. Add gas if

necessary according to the steps in the "Adding Gasoline" portion of the "Maintenance" section.

**⚠ WARNING: Gasoline and gasoline fumes are highly flammable.**

- Do not fill tank near an open flame.
- Always allow engine to cool for several minutes before refueling.
- Do not overfill (check the "Specifications" section for the tank capacity of your generator). Always check for fuel spills.

**IMPORTANT:**

- Use only UNLEADED gasoline with an octane rating of 87 or higher.
- Do not use old gas.
- Never use an oil/gasoline mixture.
- Avoid getting dirt or water in the fuel tank.
- Never store generator for extended periods of time with fuel in the tank.

***Step 3- Ground the Generator***

**⚠ WARNING: Failure to properly ground the generator can result in electrocution.**

Ground the generator by tightening the grounding nut against a grounding wire (see J figure 5). A generally acceptable grounding wire is a No. 12 AWG (American Wire Gauge) stranded copper wire. This grounding wire should be connected at the other end to a copper or brass-grounding rod that is driven into the earth.

Grounding codes can vary by location. Please contact a local electrician to check the grounding regulations for your area.

**STARTING THE GENERATOR**

**⚠ CAUTION: Disconnect all electrical loads from the generator before attempting to start.**

To start your generator, perform the following steps:

1. Make sure no electrical devices are connected to the generator. Such devices can make it difficult for the engine to start.
2. Check that the generator is properly grounded (see page 13, "Ground the Generator").
3. Turn the fuel valve to the "on" position (see figure 6).
4. Move the choke lever to the "closed" position (see figure 7).
5. Set the engine switch to the "on" position.
6. Pull on the recoil starter handle slowly until a slight resistance is felt (see figure 8). Then pull quickly to start the engine. Return cord gently into the machine. Never allow the cord to snap back.
7. If engine fails to start, repeat step 4. NOTE: After repeated attempts to start the

- engine, please consult the troubleshooting guide before attempting again.
8. Once the engine has started and run for about a minute, move the choke lever about half way towards the "open" position. Wait another 30 seconds and then move the choke lever all the way to the "open" position.
  9. Allow the generator to run for several minutes before attempting to connect any electrical devices.

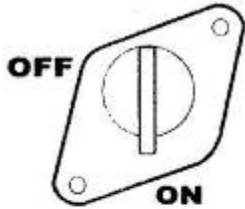

Figure 6- Fuel Valve in the "on" position

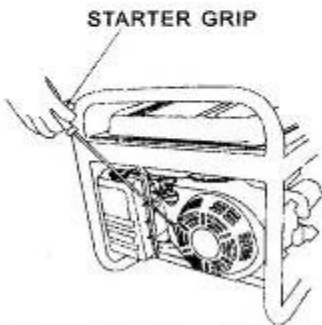

Figure 8- Pulling the start cord

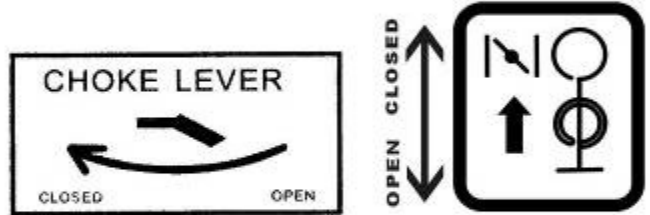

Figure 7- Choke in the "closed" position (refer to choke location)

## USING THE GENERATOR

Once you have allowed the engine to run for several minutes, you may connect electrical devices to the generator.

### AC Usage

You may connect electrical devices running on AC current according to their wattage requirements. The chart in figure 9 shows the rated and surge wattage of your generator according to its model number.

The *rated wattage* corresponds to the maximum wattage the generator can output on a continuous basis.

The *surge wattage* corresponds to the maximum amount of power the generator can output for a short period of time. Many electrical devices such as refrigerators require short bursts of extra power, in addition the rated wattage listed by the device, to stop and start their motors. The surge wattage ability of the generator covers this extra power requirement.

Model Number	Rated (Running) Wattage	Surge Wattage
XP4400	3500	4400
XP4400E	3500	4400
XP6500E	5500	6500
XP8500E	7000	8500

Figure 9-generator wattage by model number

The total running wattage requirement of the electrical devices connected to the generator should not exceed the rated wattage of the generator itself. To calculate the total wattage requirement of the electrical devices you wish to connect, find the rated (or running) wattage of each device. This number should be listed somewhere on the device or in its instruction manual. If you cannot find this wattage, you may calculate it by multiplying the Voltage requirement by the Amperage drawn:

$$\text{Watts} = \text{Volts} \times \text{Amperes}$$

If these specifications are not available you may estimate the Watts required by your device by using the chart in figure 10.

<b>Tool or Appliance</b>	<b>Rated (Running) Watts</b>	<b>Additional Surge Watts</b>
Electric water heater (40 gal)	4000	0
Hot plate	2500	0
Saw-radial arm	2000	2000
Electric stove	1500	0
Saw-circular	1500	1500
Air compressor (1HP)	1500	3000
Window air conditioner	1200	1800
Saw-miter	1200	1200
Microwave	1000	0
Well water pump	1000	1000
Reciprocating saw	960	1040
Sump pump	800	1200
Refrigerator freezer	800	1200
Furnace blower	800	1300
Computer	800	0
Electric drill	600	900
Television	500	0
Deep freezer	500	500
Garage door opener	480	0
Stereo	400	0
Box fan	300	600
Clock radio	300	0
Security system	180	0
DVD player/VCD	100	0
Common light bulb	75	0

**Figure 10- Estimated wattage requirements of common electrical devices.**

Once you have found the rated wattage requirement of each electrical device, add these numbers to find the total rated wattage you wish to draw from the generator. If this number exceeds the rated wattage of the generator, DO NOT connect all these device, Select a combination of electrical devices, which has a total rated wattage lower than or equal to the

rated wattage of the generator.

**CAUTION-**The generator can run at its surge wattage capacity for only a short time. Connect electrical devices requiring a rated (running) wattage equal to or less than the rated wattage of the generator. Never connect devices requiring a rated wattage equal to the surge wattage of the generator.

**NOTE:** The above wattage figures are estimates. Try to check the wattage listed on your electrical device before consulting this chart.

Once you have determined what electrical devices you will be powering with the generator, connect these devices according to the following procedure:

1. Plug in each electrical device with the device turned off.

**NOTE:** Be sure to attach appliances to the correct receptacle (outlet). Connect standard 120 Volt, single phase, 60 Hz loads only to the 120 Volt receptacle.

Connect 120/240 Volt, single phase, 60Hz loads with NEMA L14-30 plug **only** to the 120/240 Volt receptacle See Figure 11 for a depiction of each of these receptacles.

2. Switch the circuit breaker to the "on" position.

3. Turn on the connected electrical devices in the order of the amount of power they require beginning with the device with the highest rated Wattage requirement.

**CAUTION:** Do not connect 50Hz or 3-phase loads to the generator.

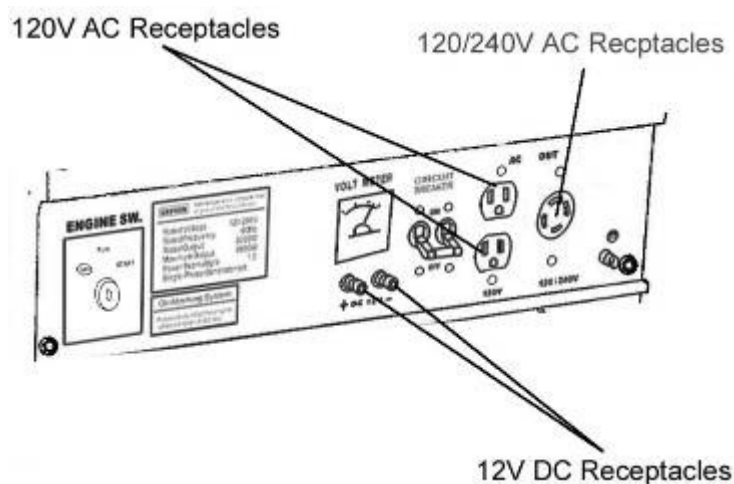

**Figure 11- Receptacles available on the generator**

### VOLTAGE SELECTOR SWITCH (XP4400/XP4400E)

The voltage selector switches the main power carrying windings of the generator to produce "120V ONLY" or "120/240V". If a 240V appliance is connected to the 4-prong receptacle, the switch must be in the "120/240V" position. If only a 120V appliance is being connected to any of the 120V 3-prong receptacles, select the "120V ONLY" position.

**120/240V:** The 120V and 120/240V receptacles can be used simultaneously.

**120V:** ONLY the 120V receptacles can be used. Do not use the 120/240V receptacle in this position. Rated power will be available at the 120V twist lock receptacle.

### **WARNING:**

Change the Voltage Selector Switch after turning the AC circuit breaker to OFF. The generator may be damaged.

## SOME NOTES ABOUT POWER CORDS

Long or thin cords can drain the power provided to an electrical device by the generator. When using such cords, allow for a slightly higher rated wattage requirement by the electrical device. See Figure 12 for recommended cords based on the power requirement of the electrical device.

Device Requirements			Max. Cord Length (ft) by Wire Gauge				
Amps	Watts (120V)	Watts (240V)	#8 wire	#10 wire	#12 wire	#14 wire	#16 wire
2.5	300	600	NR	1000	600	375	250
5	600	1200	NR	500	300	200	125
7.5	900	1800	NR	350	200	125	100
10	1200	2400	NR	250	150	100	50
15	1800	3600	NR	150	100	65	NR
20	2400	4800	175	125	75	50	NR
25	3000	6000	150	100	60	NR	NR
30	3600	7200	125	65	NR	NR	NR
40	4800	9600	90	NR	NR	NR	NR

\*NR= not recommended

**Figure 12-Maximum Extension Cord Lengths by Power Requirement**

## DC Usage

**CAUTION:** The DC receptacle is for recharging 12 Volt automotive-type batteries only. Do not connect any other device to this receptacle.

**CAUTION:** Use the generator only to recharge 12 Volt batteries. Never try to jumpstart a car with your generator.

To connect 12 Volt batteries to the DC receptacle:

1. Connect one charging wire to the positive terminal on the battery and the other charging wire to the negative terminal.
2. Connect the free end of the positive wire to the positive receptacle (outlet) on the generator.
3. Start the generator.
4. Carefully connect the free end of the negative wire to the negative receptacle on the generator.
5. When disconnecting, always disconnect the wires from the generator first to avoid a spark.

**⚠ DANGER:** Storage batteries emit highly explosive hydrogen gas when charged. Batteries also contain acid, which can cause severe chemical burns.

•Do not allow open flames or cigarettes nearby for several minutes after charging a battery.

-Always wear protective goggles and rubber gloves when charging a battery.

☆ If battery acid gets on your skin, flush with water.

☆ If battery acid gets in your eyes, flush with water and call a physician immediately.

☆ If battery acid is swallowed, drink large quantities of milk and call a physician immediately.

## STOPPING THE GENERATOR

To stop the generator:

1. Turn off, then unplug all connected electrical devices.
2. Switch the circuit breaker to the "off" position.
3. Allow the generator to run for several more minutes with no electrical devices connected. This helps stabilize the temperature of the generator.
4. Set the engine switch to the "off" position.
5. Turn the fuel valve to the "off" position.

**⚠ WARNING:** Allow the generator to cool for several minutes before touching areas that become hot during use.

**CAUTION:** Allowing gas to sit in the generator tank for long periods of time without use can make it difficult to start the generator in the future. Never store generator for extended periods of time with fuel in the tank.

## MAINTENANCE /CARE

Proper routine maintenance of your generator will help prolong the life of your machine. Please perform maintenance checks and operations according the schedule in figure 13.

**CAUTION:** Never perform maintenance operations while the generator is running.

Recommended Maintenance schedule

		Each use	Every month or 20 hrs	Every 3 months or 50 hrs	Every 6 months or 100 hrs	Every year or 300 hrs
<b>Engine oil</b>	Check level	×				
	Replace		×			
<b>Air cleaner</b>	Check	×				
	Clean			×		
<b>Fuel filter cup</b>	Clean				×	
<b>Spark plug</b>	Check/clean				×	
<b>Gas tank</b>	Check gas level	×				

	Clean		7			×
--	-------	--	---	--	--	---

**Figure 13- Recommended maintenance schedule**

### **Cleaning the Generator**

Always try to use your generator in a cool dry place. However, in the event your generator becomes dirty you may clean the exterior with one or more of the following:

- A damp clothe
- A soft brush
- A vacuum
- Pressurized air

Never clean your generator with a bucket of water or a hose. Water can get inside the working parts of the generator and cause a short circuit or corrosion.

### **Checking the Oil**

The generator is equipped with an automatic shutoff to protect it from running on low oil. Nonetheless, you should check the oil level of the generator before each use to ensure that the generator crankcase has a sufficient amount. To check the oil level:

1. Make sure the generator is on a level surface.
2. Unscrew the oil filler/dipstick cap (see figure 14).
3. With a dry cloth, wipe the oil off of the stick on the inside of the cap.
4. Insert the dipstick as if you were replacing the cap and then remove again. There should now be oil on the stick. If there is no oil on the stick, or oil only at the very end of the stick, you should add oil until the engine crankcase is filled. See "Changing/ Adding Oil" in this section.
5. Be sure to replace cap when finished checking oil.

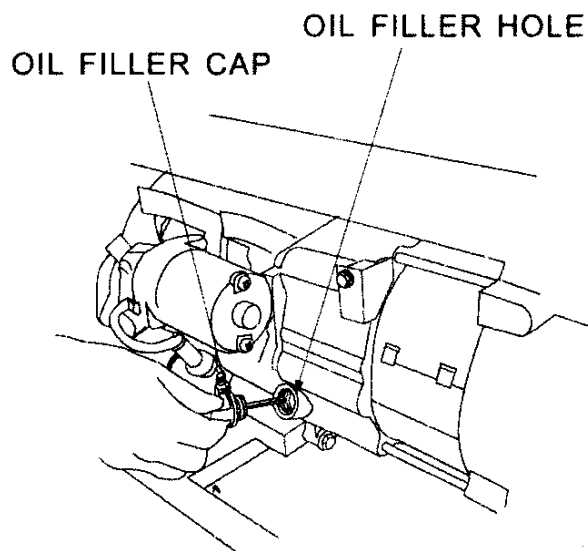

**Figure 14- Checking the Oil**

### **Changing/ Adding Oil**

You should check the oil level of your generator according to the maintenance schedule in

figure 13. When the oil level is low you will need to add oil until the level is sufficient to run the generator.

The oil capacity of your generator engine is listed in figure 15.

Model number	XP4400	XP4400E	XP6500E	XP8500E
Engine oil capacity	20 fluid oz.	20 fluid oz.	37 fluid oz.	37 fluid oz.

**Figure 15- Engine Oil Capacity.**

It is only necessary to drain the oil from the crankcase if it has become contaminated with water or dirt. In this case, you can drain the oil from the generator according to the following steps:

1. Place a bucket underneath the generator to catch oil as it drains.
2. Using a 10 mm hex wrench, unscrew the oil drain plug, which is located on the crankcase underneath the oil filler/dipstick cap (see figure 16). Allow all the oil to drain from the generator.
3. Replace the oil drain plug and tighten with a 10 mm hex wrench.

To add oil to the crankcase, follow these steps:

1. Make sure the generator is on a level surface.
2. Unscrew the oil filler/dipstick cap from the engine as shown in figure 14 above.
3. Using a funnel, add high detergent motor oil to the crankcase. We recommend SAE 10W30 motor oil for general use. When full, the oil level should come close in the top of the oil fill opening (see figure 17).

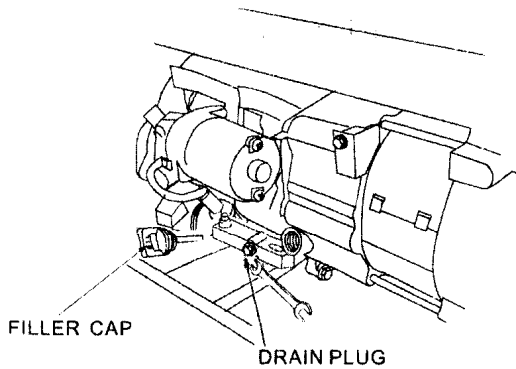

**Figure 16- Draining oil**



**Figure 17- Adding oil**

**NOTE: Never dispose of used motor oil in the trash or down a drain. Please call your local recycling center or auto garage to arrange oil disposal.**

### Air Cleaner Maintenance

Routine maintenance of the air cleaner helps maintain proper airflow to the carburetor. Occasionally check that the air cleaner is free of excessive dirt.

1. Unhinge the clasps at the top and bottom of the air cleaner cover (see figure 18).
2. Remove the sponge-like elements from the casing.
3. Wipe the dirt from inside the empty air cleaner casing
4. Wash the sponge-like elements in household detergent and warm water. Allow to

drying.

5. Soak the dry elements in engine oil. Squeeze out any excess oil.
6. Replace the sponge-like elements in the air cleaner casing and replace the cover.

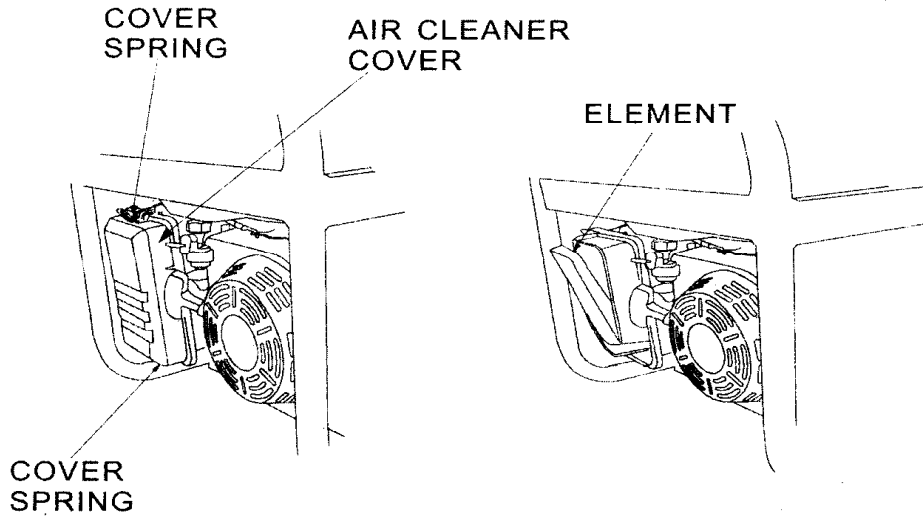
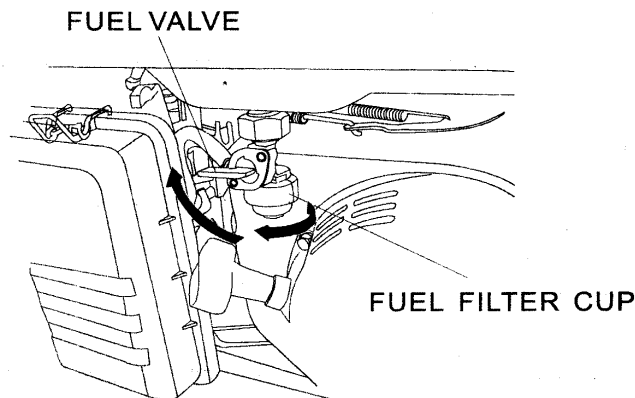

**Figure 18- Removing the air cleaner casing.**

### **Fuel Filter Cup Cleaning**

The fuel filter cup is a small well underneath the fuel valve. It helps to trap dirt and water that may be in your fuel tank before it can enter the engine. To clean the fuel filter cup:

1. Turn the fuel valve to the "OFF" position.
2. Unscrew the fuel filter cup from the fuel valve using a wrench. Turn the valve toward you to unscrew (see figure 19).
3. Clean the cup of all sediment. Using a rag or brush.
4. Reinstall the fuel filter cup.



**Figure 19 –Removing the Fuel Filter Cup**

### **Spark Plug Maintenance**

The spark plug is important for proper engine operation. A good spark plug should be intact, free of deposits, and properly gapped. To inspect your spark plug:

1. Pull on the spark plug cap to remove it.
2. Unscrew the spark plug from the generator using the spark plug wrench included with this product (see figure 20).
3. Visually inspect the spark plug. If it is cracked or chipped, discard and replace with a new spark plug. We recommend using a F6RTC spark plug such as NGKBPR5ES.
4. Measure the plug gap with a gauge (see figure 21). The gap should be 0.7-0.8 nun (0.028—

0.031 in).

5. If you are re-using the spark plug, use a wire brush to clean any dirt from around the spark plug base and then re-gap the spark plug.
6. Screw the spark plug back into its place on the generator using the spark plug wrench. Replace the spark plug cap.

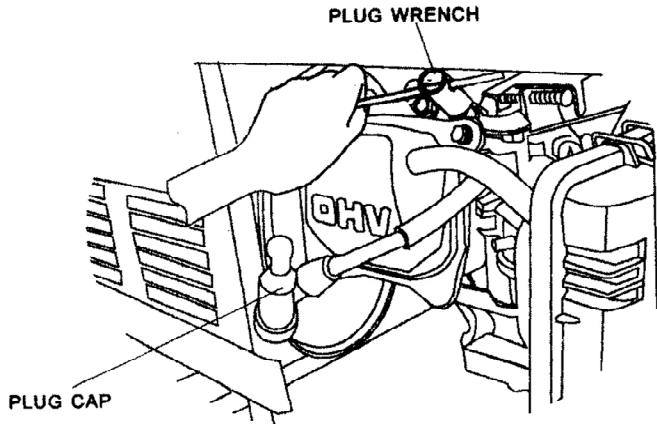

**Figure 20- Removing the spark plug**

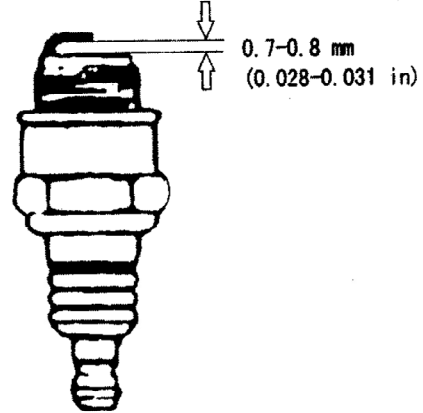

**Figure 21- Measuring the spark plug gap**

### Emptying the Gas Tank

Before storing your generator for extended periods of time, you should drain your generator of gasoline. To drain the generator of gas:

1. Turn the fuel valve to the "off" position.
2. Remove the fuel filter cup (see "Removing the Fuel Filter Cup" earlier in this section).
3. Empty the fuel filter cup of any fuel.
4. With a receptacle underneath the generator to catch the gas, turn the fuel valve to the "on" position. Drain all the gas from the generator.
5. Turn the fuel valve to the "OFF" position.
6. Replace the fuel filter cup.
7. Store the emptied gasoline in a suitable place.

**⚠ CAUTION: Do not store fuel from one season to another.**

## STORAGE/TRANSPORT PROCEDURES

**⚠ CAUTION: Never place any type of storage cover on the generator while it is still hot.**

When transporting or storing your generator for extended periods of time:

- Empty the gas tank (see "Emptying the Gas Tank" in the "Maintenance" section).
- Disconnect the spark plug.
- Do not obstruct any ventilation openings.
- Keep the generator in a cool dry area.

# SPECIFICATIONS

## Generator

### AC Output

	<b>XP4400</b>	<b>XP4400E</b>	<b>XP6500E</b>	<b>XP8500E</b>
Rated Wattage	3500W	3500W	5500W	7000W
Surge Wattage	4400W	4400W	6500W	8500W
Rated Voltage	120/240V	120/240V	120/240V	120/240V
Rated Frequency	60Hz	60Hz	60Hz	60Hz
Phase	Single	Single	Single	Single

### DC Output

	<b>XP4400</b>	<b>XP4400E</b>	<b>XP6500E</b>	<b>XP8500E</b>
Voltage	12V	12V	12V	12V
Amperage	8.3A	8.3A	8.3A	8.3A
Dimensions (in):	Length=23.2 width=17 height=17	Length=23.2 width=17 height=17	Length=28 width=20 height=21.3	Length=28 width=20 height=21.3

### Engine

	<b>XP4400</b>	<b>XP4400E</b>	<b>XP6500E</b>	<b>XP8500E</b>
Engine type	4-stroke OHV single cylinder with forced air cooling system			
Ignition system	Non-contact transistor			
Displacement	200cc		389cc	419cc
Starting type	Recoil	Electric start		
Fuel tank capacity:	15L(3.96US gal.)		25L(6.6US gal.)	
Oil capacity	0.6L(20fl oz.)		1.1L(37fl oz.)	
Run time on 50% load	14hrs	12 hrs	12hrs	10hrs

# TROUBLESHOOTING

<b>Problem</b>	<b>Cause</b>	<b>Solution</b>
Engine will not start	Engine switch is set to "off".	Set engine switch to "on".
	Fuel valve is turned to "closed".	Turn fuel valve to "open" position.
	Choke is open.	Close the choke
	Engine is out of gas.	Add gas.
	Engine is filled with contaminated or old gas	Change the gas on the engine.
	Spark plug is dirty.	Clean spark plug.

	Spark plug is broken.	Replace spark plug.
	Generator is not on level surface.	Move generator to a level surface to prevent low oil shutdown from triggering.
	Oil is low	Add or replace oil.
Engine runs but there is no electrical output	Circuit breaker is off.	Set the circuit breaker to the "on" position.
	Bad connecting wires/cables.	If you are using an extension cord, try a different one.
	Bad electrical device connected to generator.	Try connecting a different device.
Generator runs but does not support all electrical devices connected.	Generator is overloaded	Try connecting fewer electrical loads to the generator.
	Short in one of the connected devices.	Try disconnecting any faulty or short-circuited electrical loads.
	Air cleaner is dirty.	Clean or replace air cleaner.

## GENERATOR ASSEMBLY AND MOUNTING

Generator is supplied with a wheel kit. If you want to install the wheel kit on your unit, please follow the instructions below. If you will not be using the wheel kit, skip this section.

1. Place the bottom of the generator cradle on a flat, even surface. Temporarily place unit on blocks to ease assembly.
2. Secure the support leg to the cradle with cap screws (M8 x 16) and lock nuts (M8) (see figure 22 ).
3. Secure the axle to the cradle with cap screws (M8 x 16) and lock nuts (M8) (see figure 23).
4. Slide a wheel (with the inflation valve facing out) and a flat washer over the axle, then secure the wheel with a retaining pin (see figure 24、 Figure 25、 Figure 26).
5. Position the handles on the cradle and attach with plastic flat washer, cap screws(M8 X 16) and lock nuts(M8)( Figure 27、 Figure 28).
5. Check that all fasteners are tight and tires are inflated between 15-40 PSI.



Figure 22



Figure 23



Figure 24



Figure 25



Figure 26

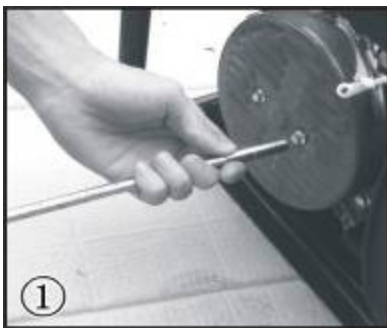

Figure 27

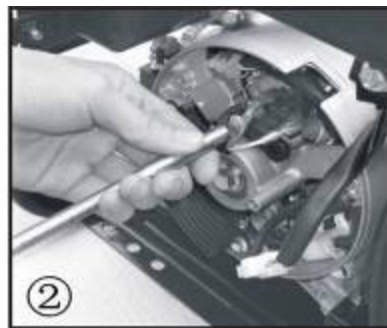

Figure 28

## CHANGE THE CARBON-BRUSH



① Dismantle the 2 bolts (M5X12) of electric machine back-cover.



② Take down the installed bolts (M5X16) of carbon-brush.



③ Take down the carbon-brush from DC wire of excitation.



Install the new carbon-brush with bolts (M5X16).



Insert and connect the DC wire of excitation according to anode-cathode.

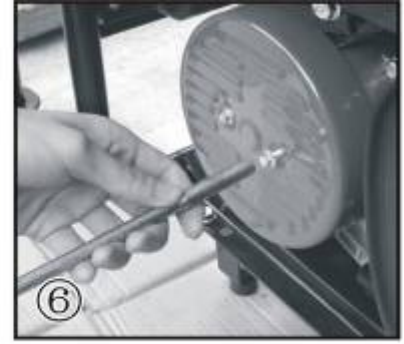

Install the electric machine back-cover with 2bolts (M5X12).

## CHANGE THE AVR

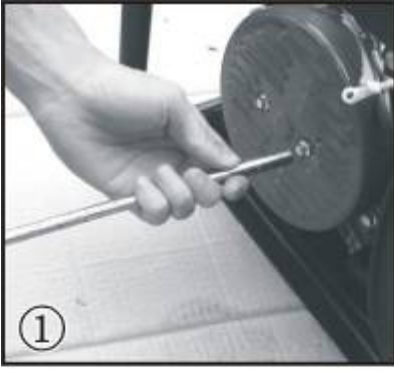

① Dismantle the 2 bolts (M5X12) of electric machine back-cover.



② Take down the 2 installed bolts (M5X16) of AVR.



③ Disconnect the sample wire hindered.



④ Take down the AVR from carbon-brush

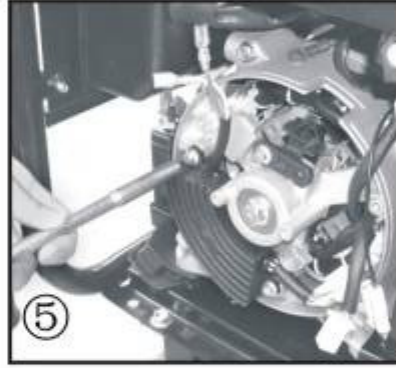

⑤ Install the new AVR with 2 bolts (M5X16)

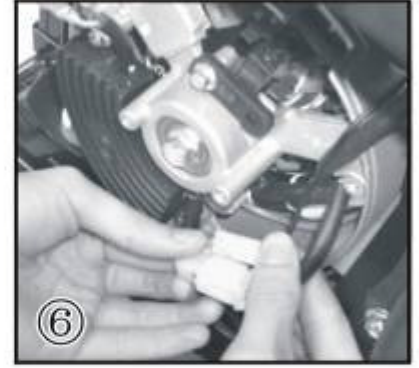

⑥ Connect the sample wire hindered.



⑦ Insert and connect the DC wire of excitation according to anode-cathode.

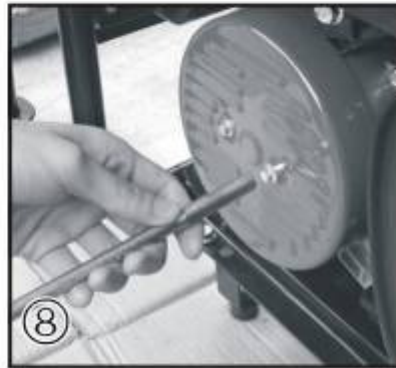

⑧ Install the electric machine back-cover with 2 bolts (M5 X12)

# WIRING DIAGRAM(XP4400)

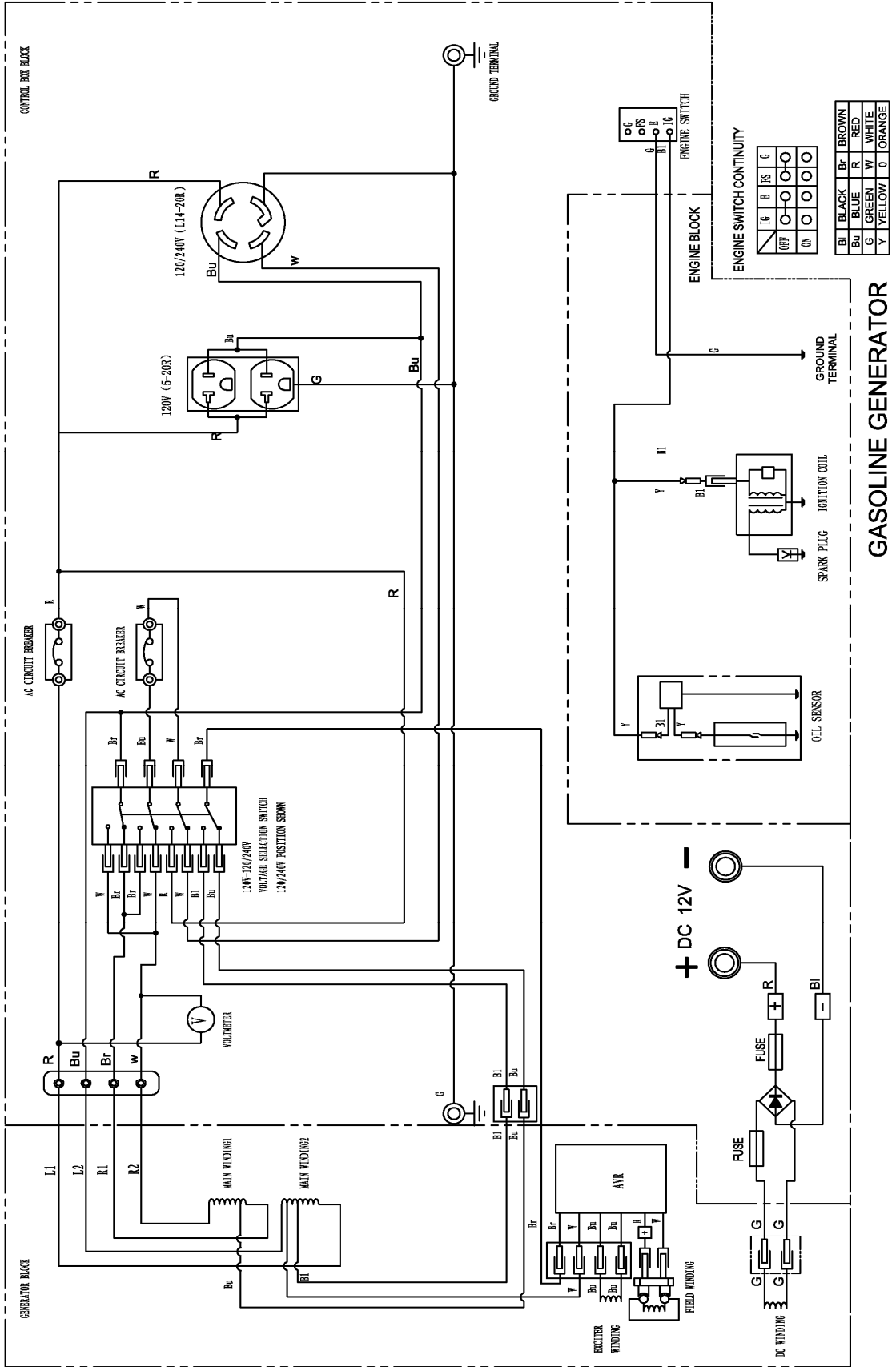

# WIRING DIAGRAM(XP4400E)

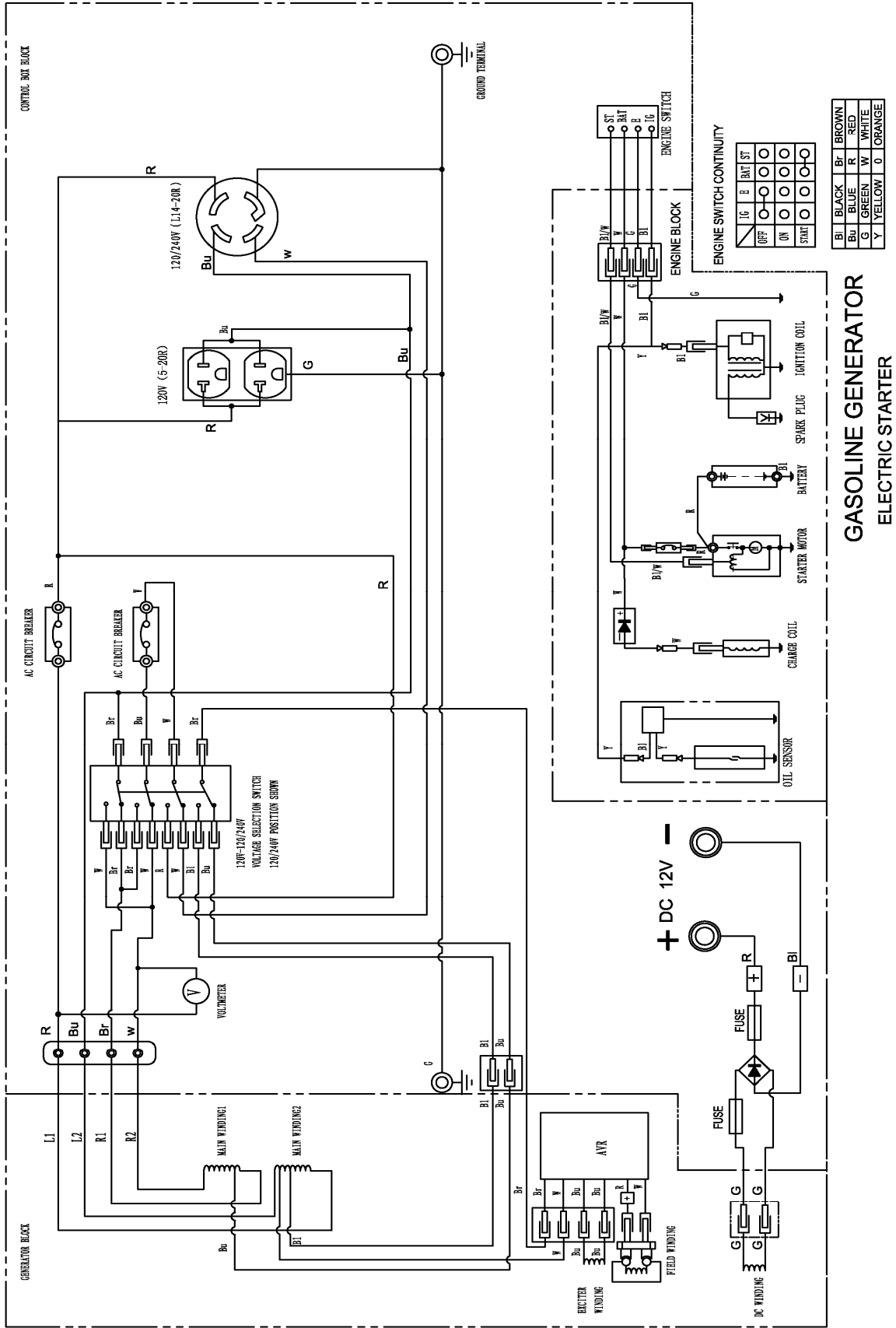

# WIRING DIAGRAM(XP6500E/XP8500E)

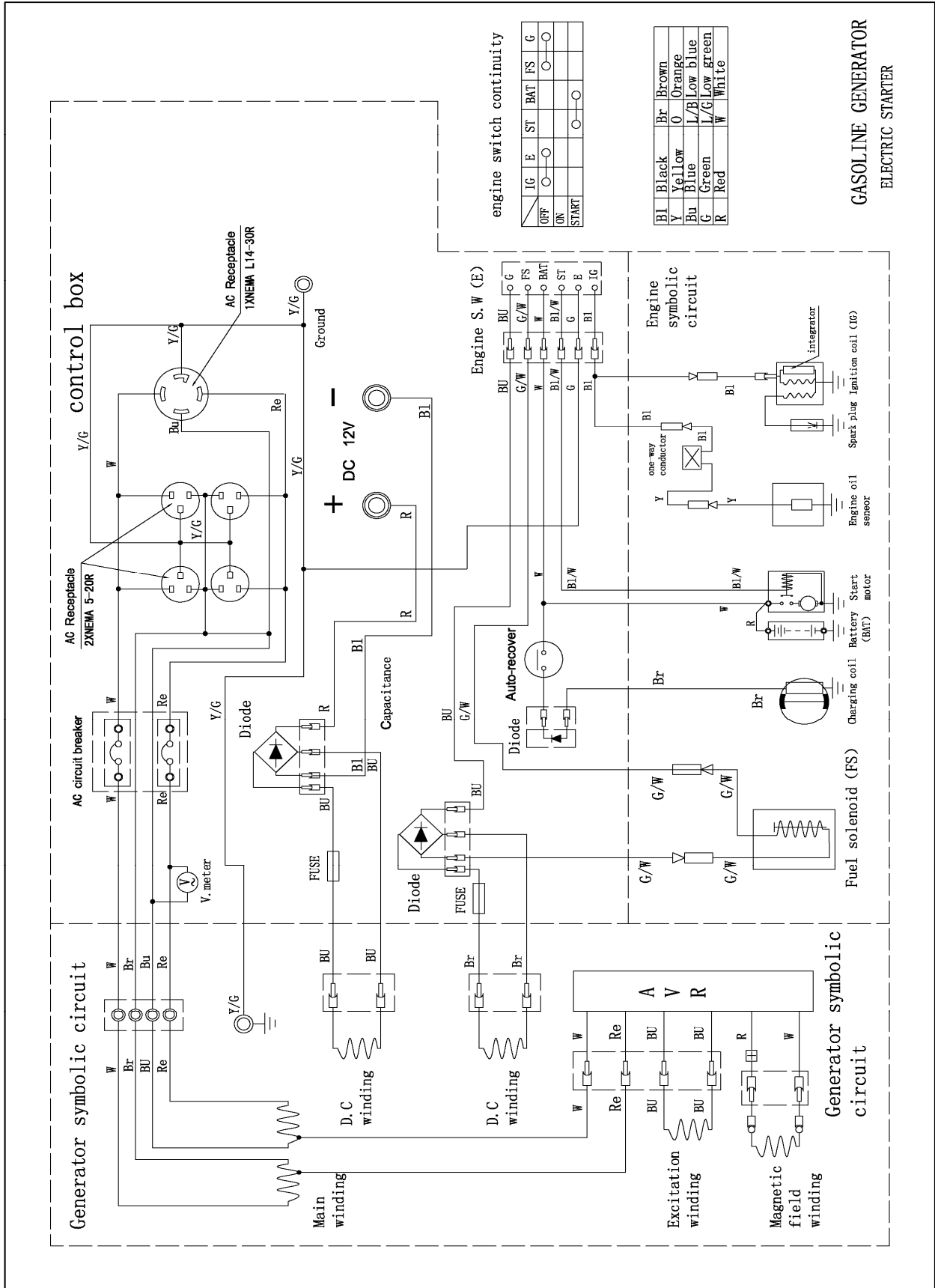

# EXPLODED VIEW AND PARTS LIST(XP4400)

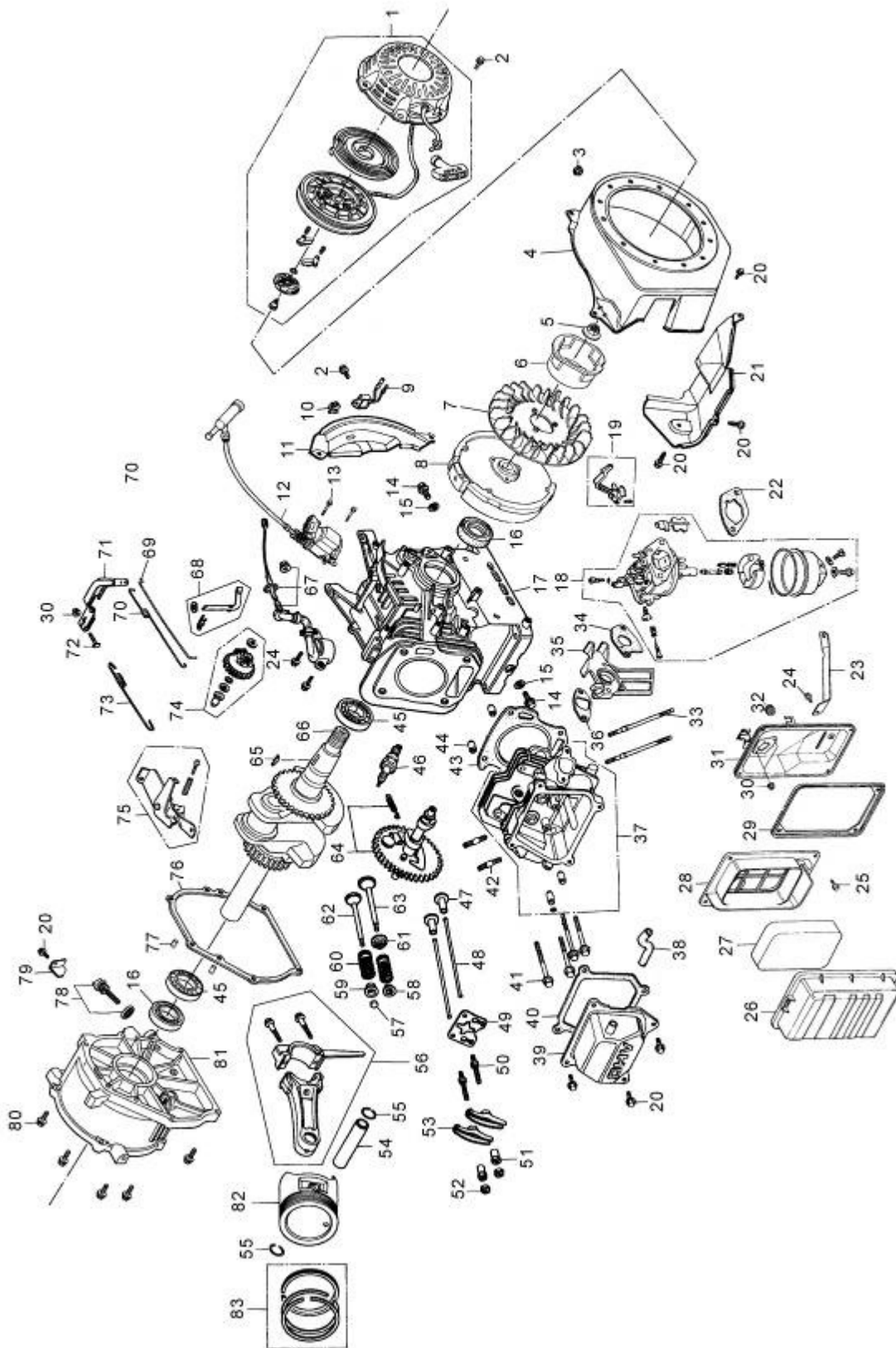

Item	Part	Qty	Description	Item	Part	Qty	Description
1	21100	1	Starter comp, recoil	43	90007	1	Casket, cylinder head
2	GB5787-86	4	Flange bolt M6×8	44	92002	2	Pin, dowel, 10×16
3	12302	1	Grommet drain hole	45	GB/T276-94	2	Radial ball bearing (6025)
4	12310	1	Fan, cover comp	46	11202	1	Plug, spark
5	GB6177-86	1	Flange nut M14	47	15002	2	Lifter, valve
6	19005	1	Pulley, starter	48	15001	2	Rod, push
7	19001	1	Fan, cooling	49	11215	1	Plate, push rod guide
8	81200	1	Flywheel comp	50	11214	2	Bolt, pivot
9	87500	1	Amplifier	51	11204	2	Nut, Arm, valve rocker
10	12302	1	Clip. Wire darkness	52	11206	2	Nut, pivot adjusting
11	19002	1	Plate, side	53	11205	2	Arm, valve rocker
12	81100	1	Coil assy. ignition	54	13104	1	Pin, piston
13	GB5789-86	10	Flange bolt M6×25	55	13015	2	Clip, piston pin
14	13203	2	Bolt, drain lug	56	13106	1	Connecting rod assy.
15	12217	2	Washer, drain lug	57	11213	1	Rotator, valve
16	900008	2	Oil seal, 25×41×6	58	11211	1	Retainer, IN. Valve spring
17	12200	1	Crank case assy.	59	11212	1	Retainer, EX. Valve spring
18	17300	1	Carburetor assy.	60	11206	2	Spring, valve
19	17316	1	Lever comp, choke	61	11216	1	Seat, valve spring
20	GB5787-86	15	Flange bolt M6×12	62	11209	1	Valve, EX.
21	19003	1	Shroud comp	63	11208	1	Valve, IN.
22	90002	1	Packing air cleaner	64	15100	1	Camshaft assy.
23	12006	1	Stay, air cleaner	65	GB/T 99-88	1	Key, 25×18
24	GB5789-86	7	Flange bolt M6×12	66	13000	1	Crankshaft comp
25	GB5786-86	4	bolt M5×12	67	87400	1	Switch assy. oil level
26	16004	1	Cover comp, air cleaner	68	12208	1	Shaft, governor assy.
27	16001	1	Element, air cleaner	69	17003	1	Rod, governor
28	16002	1	Separator, air cleaner	70	17002	1	Spring, throttle return
29	16005	1	Seal, air cleaner	71	17004	1	Arm, governor
30	GB6177-86	2	Flange nut M6	72	91003	1	Bolt, governor arm
31	16003	1	Case comp, air cleaner	73	17001	1	Spring, governor
32	12012	1	Grommet fender	74	12230	1	Governor assy.
33	91004	2	Bolt head, 6×94	75	17200	1	Control assy.
34	90003	1	Packing, carburetor	76	90001	1	Packing, case cover
35	90004	1	Insulator, carburetor	77	92003	2	Pin, dowel, 8×14
36	90005	1	Packing, insulator	78	12102	1	Cap assy. oil filler
37	11250	1	Head comp, cylinder	79	12105	1	Plat
38	92001	1	Casket, muffler	80	GB5789-86	6	Flange bolt M8×32
39	11240	1	Cover comp, head	81	12100	1	Crankcase cover
40	90006	1	Exhaust piper	82	13101	1	Piston
41	GB5789-86	4	Flange bolt M8×60	83	13100	1	Ping set, piston
42	91005	2	Bolt head, M8×32	84		1	Gasoline engine

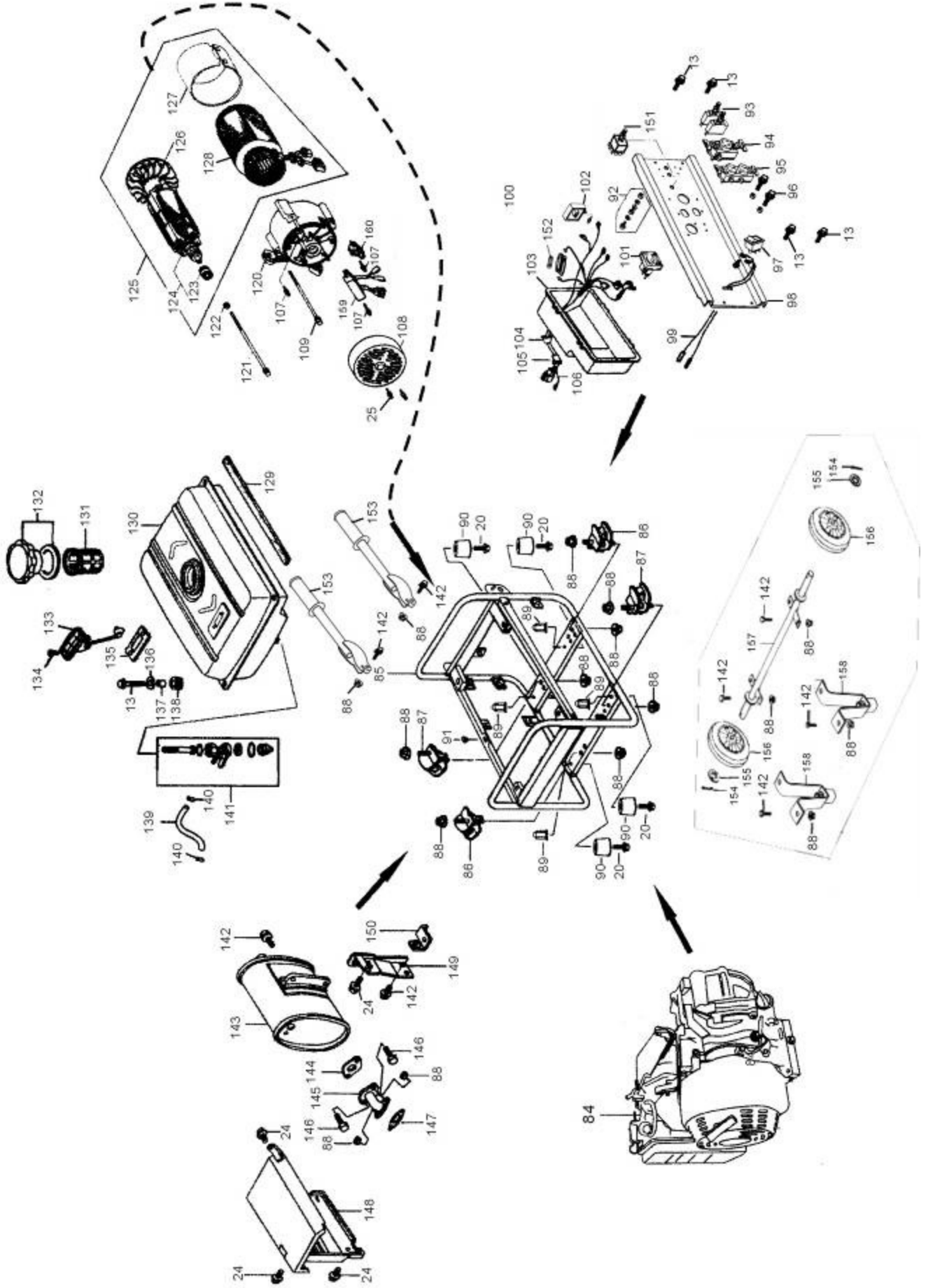

Item	Part	Qty	Description	Item	Part	Qty	Description
84		1	Gasoline engine	136	14022	4	Washer
85	10100	1	Frame comp	137	14023	4	Collar
86	15002	2	Bottom rubber A	138	14014	4	Cushion
87	15003	2	Bottom rubber B	139	50010	1	Outlet pipeφ4.5×165
88	GB6177-86	20	Flange nut M8	140	50012	2	Tube clip
89	GB802-88	4	Flange nut M6	141	14300	1	Fuel cock
90	41350	4	Cushion, frame	142	GB5787-86	13	Flange bolt M8×16
91	15001	2	Rubber pad, frame	143	18100	1	Muffler
92	20110	1	Earth terminal set	144	90001	1	Muffler gasket
93	20014	1	Circuit breaker	145	15001	1	Exhaust pipe comp
94	20015	1	Receptacle (30A)	146	GB5787-86	2	Flange bolt M8×25
95	20030	2	Receptacle (20A)	147	90002		Exhaust pipe gasket
96	20140	2	DC output post	148	10030	1	Muffler guard
97	20020	1	Engine switch	149	10040	1	Muffler stay
98	20011	1	Control panel	150	10081	1	Supporting plate
99	20013	1	Sub harness	151	20050	1	Voltage selection switch
100	11090	1	Auto-recover	152	20053	1	Fuse
101	20410	1	Voltmeter	153	15201	2	Hand push
102	20420	1	Diode assay	154	21050	2	Pin.
103	20061	1	Control panel case	155	GB97.1-85	2	Washer φ20
104	20082	1	Boot, main wire harness	156	21040	2	Wheel comp
105	20081	1	Boot, AC output wire	157	21010	1	Well shaft
106	20070	1	Wire harness Assy.	158	21020	2	Bracket
107	GB5787-86	2	Flange bolt M5×14	159	13040	1	Voltage regulator
108	13021	1	Generator end cover	160	13030	1	Brush assy.
109	GB5789-86	4	Flange bolt M6×125				
120	13001	1	Support stand				
121	GB5789-86	1	Bolt M8×180				
122	GB9701-85	1	Plain washerφ10				
123	GB276-89	1	Bearing 6204-2RS				
124	11020	1	Rotor comp				
125	11000	1	Stator & Rotor Assy.				
126	11030	1	Generator fan				
127	10060	1	Stator cover				
128	12000	1	Stator Assy.				
129	14301	1	Stripe, fuel tank				
130	14000	1	Fuel tank				
131	14101	1	Fuel filter				
132	14400	1	Fuel filler cap comp				
133	14200	1	Fuel sensor				
134	GB819-95	2	Screw M5×10				
135	14211	1	Casket fuel tank				

# EXPLODED VIEW AND PARTS LIST(XP4400E)

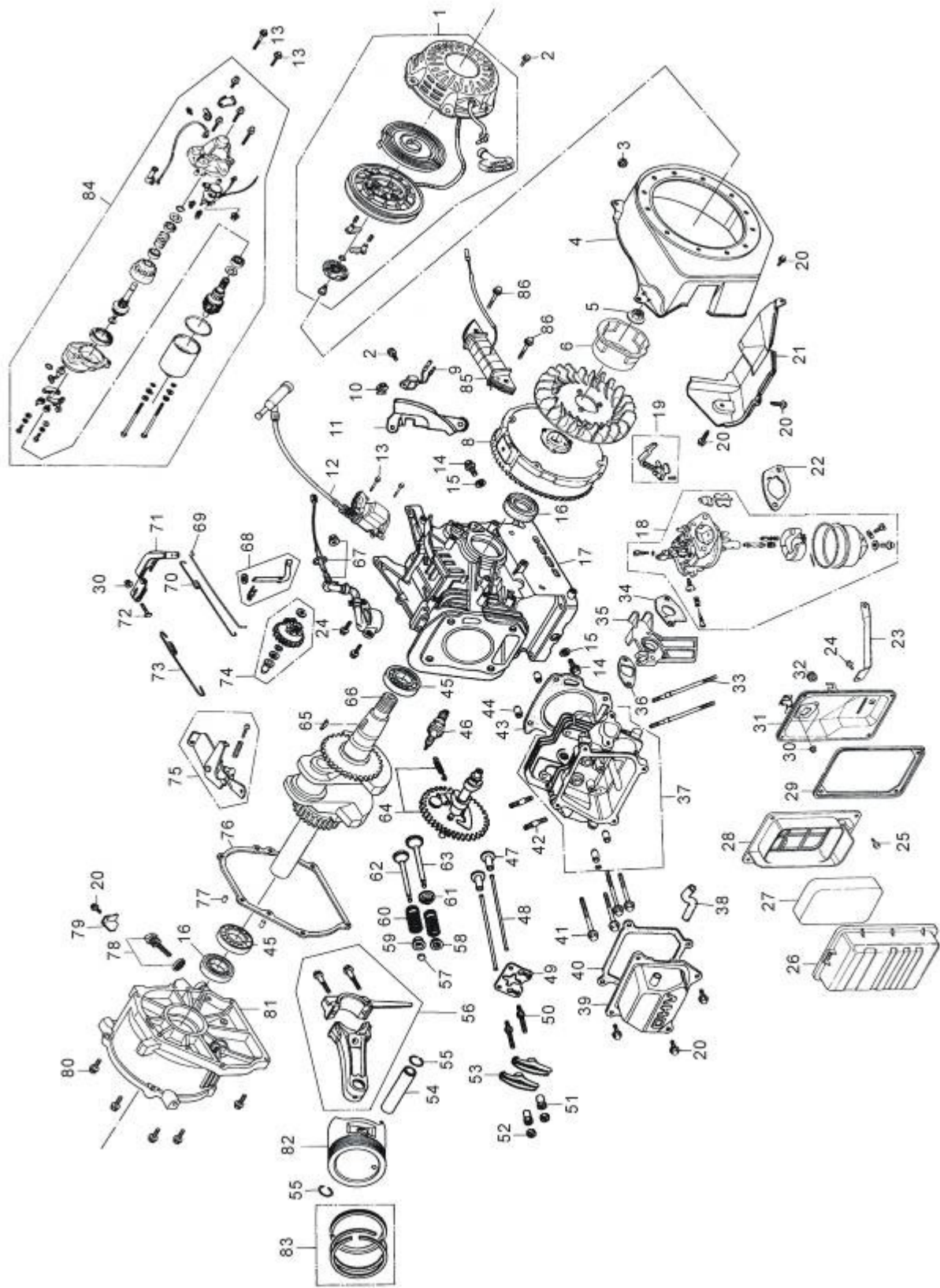

Item	Part	Qty	Description	Item	Part	Qty	Description
1	21100	1	Starter comp, recoil	44	92002	2	Pin, dowel, 10×16
2	GB5787-86	4	Flange bolt M6×8	45	GB/T276-94	2	Radial ball bearing (6025)
3	12302	1	Grommet drain hole	46	11202	1	Plug, spark
4	12310	1	Fan, cover comp	47	15002	2	Lifter, valve
5	GB6177-86	1	Flange nut M14	48	15001	2	Rod, push
6	19005	1	Pulley, starter	49	11215	1	Plate, push rod guide
7	19001	1	Fan, cooling	50	11214	2	Bolt, pivot
8	81200	1	Flywheel comp	51	11204	2	Nut, Arm, valve rocker
9	87500	1	Amplifier	52	11206	2	Nut, pivot adjusting
10	12302	1	Clip. Wire darkness	53	11205	2	Arm, valve rocker
11	19002	1	Plate, side	54	13104	1	Pin, piston
12	81100	1	Coil assy. ignition	55	13015	2	Clip, piston pin
13	GB5789-86	2	Flange bolt M6×25	56	13106	1	Connecting rod assy.
14	13203	2	Bolt, drain lug	57	11213	1	Rotator, valve
15	12217	2	Washer, drain lug	58	11211	1	Retainer, IN. Valve spring
16	900008	2	Oil seal, 25×41×6	59	11212	1	Retainer, EX. Valve spring
17	12200	1	Crank case assy.	60	11206	2	Spring, valve
18	17300	1	Carburetor assy.	61	11216	1	Seat, valve spring
19	17316	1	Lever comp, choke	62	11209	1	Valve, EX.
20	GB5787-86	11	Flange bolt M6×12	63	11208	1	Valve, IN.
21	19003	1	Shroud comp	64	15100	1	Camshaft assy.
22	90002	1	Packing air cleaner	65	GB/T 99-88	1	Key, 25×18
23	12006	1	Stay, air cleaner	66	13000	1	Crankshaft comp
24	GB5789-86	3	Flange bolt M6×12	67	87400	1	Switch assy. oil level
25	GB5786-86	4	bolt M5×12	68	12208	1	Shaft, governor assy.
26	16004	1	Cover comp, air cleaner	69	17003	1	Rod, governor
27	16001	1	Element, air cleaner	70	17002	1	Spring, throttle return
28	16002	1	Separator, air cleaner	71	17004	1	Arm, governor
29	16005	1	Seal, air cleaner	72	91003	1	Bolt, governor arm
30	GB6177-86	2	Flange nut M6	73	17001	1	Spring, governor
31	16003	1	Case comp, air cleaner	74	12230	1	Governor assy.
32	12012	1	Grommet fender	75	17200	1	Control assy.
33	91004	2	Bolt head, 6×94	76	90001	1	Packing, case cover

34	90003	1	Packing, carburetor	77	92003	2	Pin, dowel, 8×14
35	90004	1	Insulator, carburetor	78	12102	1	Cap assy. oil filler
36	90005	1	Packing, insulator	79	12105	1	Plat
37	11250	1	Head comp, cylinder	80	GB5789-86	6	Flange bolt M8×32
38	92001	1	Casket, muffler	81	12100	1	Crankcase cover
39	11240	1	Cover comp, head	82	13101	1	Piston
40	90006	1	Exhaust piper	83	13100	1	Ping set, piston
41	GB5789-86	4	Flange bolt M8×60	84	21000	1	Start motor
42	91005	2	Bolt head, M8×32	85	21101	1	Coil assy. excitation
43	90007	1	Casket, cylinder head	86	GB5789-86	2	Flange bolt M6×28

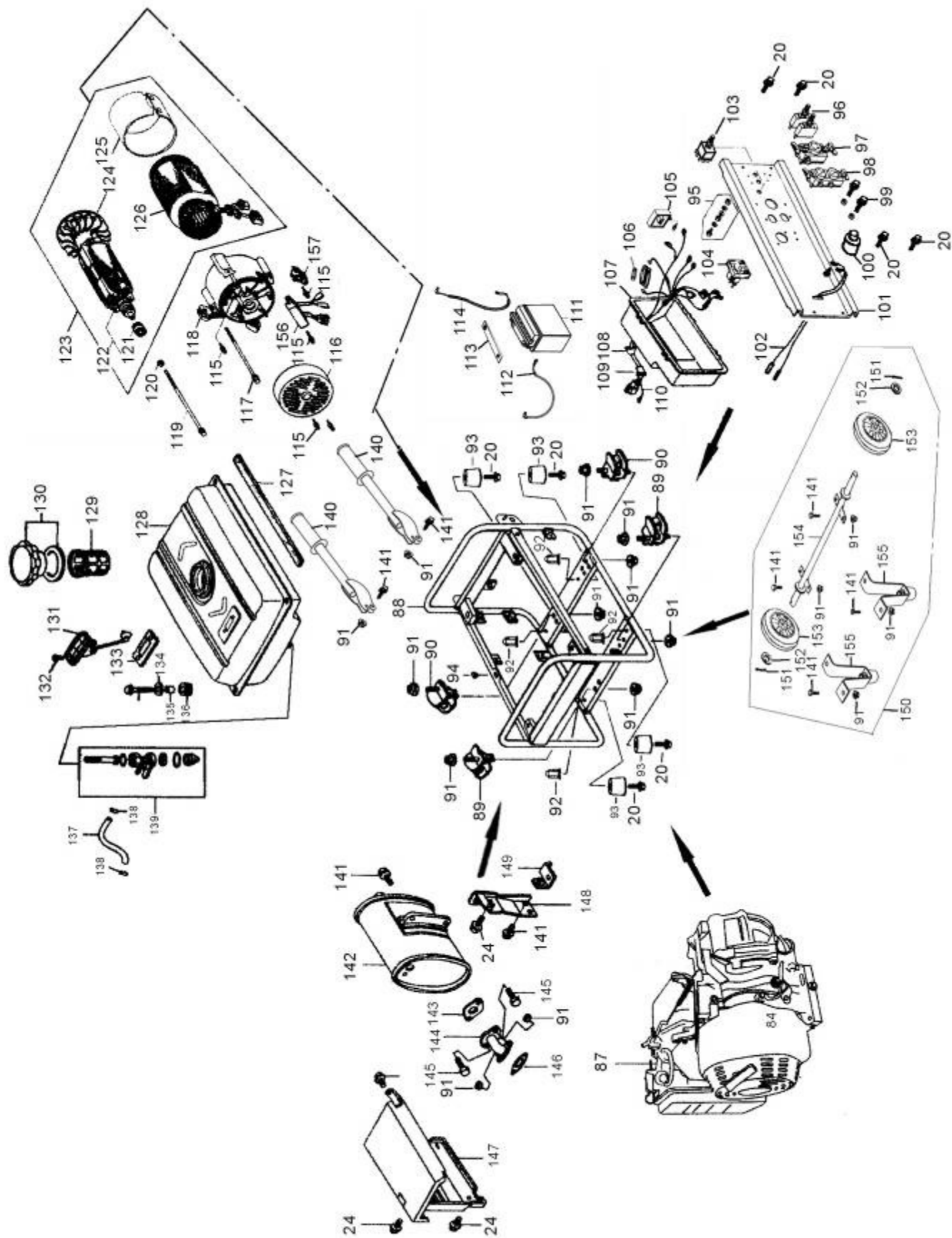

Item	Part	Qty	Description	Item	Part	Qty	Description
------	------	-----	-------------	------	------	-----	-------------

87		1	Gasoline engine	129	14101	1	Fuel filter
88	10100	1	Frame comp	130	14400	1	Fuel filler cap comp
89	15002	2	Bottom rubber A	131	14200	1	Fuel sensor
90	15003	2	Bottom rubber B	132	GB819-95	2	Screw M5×10
91	GB6177-86	18	Flange nut M8	133	14211	1	Casket fuel tank
92	GB802-88	4	Flange nut M6	134	14022	4	Washer
93	41350	4	Cushion, frame	135	14023	4	Collar
94	15001	2	Rubber pad, frame	136	14014	4	Cushion
95	20110	1	Earth terminal set	137	50010	1	Outlet pipeφ4.5×165
96	20014	1	Circuit breaker	138	50012	2	Tube clip
97	20015	1	Receptacle (30A)	139	14300	1	Fuel cock
98	20030	2	Receptacle (20A)	140	15201	2	Hand push
99	20140	2	DC output post	141	GB5787-86	17	Flange bolt M8×16
100	20020	1	Engine switch	142	18100	1	Muffler
101	20011	1	Control panel	143	90001	1	Muffler gasket
102	20013	1	Sub harness	144	15001	1	Exhaust pipe comp
103	20050	1	Voltage selection switch	145	GB5787-86	2	Flange bolt M8×25
104	20410	1	Voltmeter	146	90002		Exhaust pipe gasket
105	20420	1	Diode assay	147	10030	1	Muffler guard
106	20053	1	Fuse	148	10040	1	Muffler stay
107	20061	1	Control panel case	149	10081	1	Supporting plate
108	20082	1	Boot, main wire harness	150	21000	1	Wheel Assy.
109	20081	1	Boot, AC output wire	151	21050	2	Pin.
110	20070	1	Wire harness Assy.	152	GB97.1-85	2	Washer φ20
111	22010	1	Battery	153	21040	2	Wheel comp
112	22001	1	Positive wire of battery	154	21010	1	Well shaft
113	22002	1	Battery cover	155	21020	2	Bracket
114	22005	1	Negative wire of battery	156	13040	1	Voltage regulator
115	GB5787-86	2	Flange bolt M5×12	157	13030	1	Brush assy.
116	13021	1	Generator end cover				
117	GB5789-86	4	Flange bolt M6×125				
118	13001	1	Support stand				
119	GB5789-86	1	Bolt M8×180				
120	GB9701-85	1	Plain washerφ10				
121	GB276-89	1	Bearing 6204-2RS				
122	11020	1	Rotor comp				
123	11000	1	Stator & Rotor Assy.				

124	11030	1	Generator fan				
125	10060	1	Stator cover				
126	12000	1	Stator Assy.				
127	14301	1	Stripe, fuel tank				
128	14000	1	Fuel tank				

**EXPLODED VIEW AND PARTS LIST(XP6500E/XP8500E)**

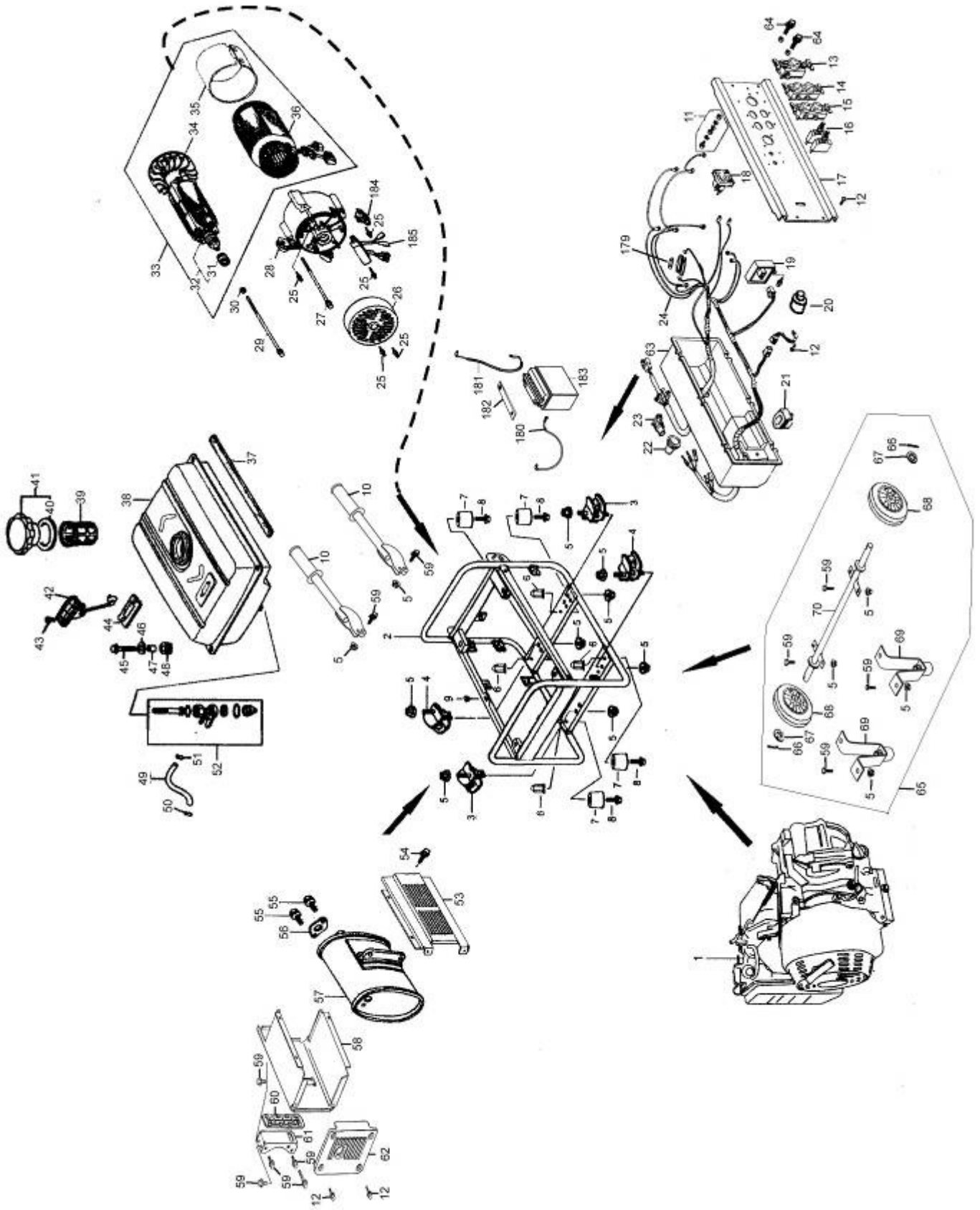

Item	Part	Qty	Description	Item	Part	Qty	Description
1		1	Gasoline engine	42	14400	1	Fuel sensor

2	15100	1	Frame comp	43	GB 819-95	2	Screw M5×10
3	15002	2	Bottom rubber A	44	14410	1	Casket fuel tank
4	15003	2	Bottom rubber B	45	GB5787-86	4	Flange bolt M6×22
5	GB6177-86	12	Flange nut M8	46	14022	4	Washer
6	GB802-88	4	Flange nut M6	47	14005	4	Collar
7	41350	4	Cushion, frame	48	14001	4	Cushion
8	GB5787-86	4	Bolt M6×12	49	14004	1	Outlet pipeφ4.5×165
9	15001	2	Rubber pad, frame	50	14006	2	Tube clip
10	15201	2	Hand push	51	14003	1	Rubber, fuel tube
11	11010	1	Earth terminal set	52	14100	1	Fuel cock
12	GB5787-86	8	Flange bolt M6×12	53	13001	1	Protector comp muffler
13	11070	1	Receptacle (30A)	54	GB5787-86	4	Flange bolt M6×14
14	11092	1	Receptacle (20A)	55	GB5787-86	2	Flange bolt M8×32
15	11072	1	Receptacle (20A)	56	13010	1	Muffler stay
16	11120	2	Circuit protector	57	13020	1	Muffler
17	11090	1	Control panel	58	13002	1	Protector muffler inner
18	11110	1	Voltmeter	59	GB5789-86	4	Flange bolt M8×16
19	11050	2	Diode assay	60	13004	1	Seal protector muffler
20	11082	1	Engine switch	61	13005	1	Muffler, stay comp
21	11040	1	Boot, switch wire	62	13003	1	Protector muffler side
22	11030	1	Boot, main wire harness	63	11091	1	Control panel case
23	11010	1	Boot, AC output wire	64	11101	2	DC output post
24	11060	1	Wire harness Assy.	65	21000	1	Wheel Assy.
25	GB5787-86	2	Flange bolt M5×12	66	21050	2	Pin.
26	16004	1	Generator end cover	67	GB97.1-85	2	Washer φ20
27	GB5789-86	4	Flange bolt M6×175	68	21040	2	Wheel comp
28	16003	1	Support stand	69	21020	2	Bracket
29	GB5789-86	1	Bolt M10×1.25×265	70	21010	1	Well shaft
30	GB9701-85	1	Plain washerφ10	179	20053	1	Fuse
31	GB276-89	1	Bearing 6207-2RS	180	22001	1	Positive wire of battery
32	16200	1	Rotor comp	181	22002	1	Negative wire of battery
33	16000	1	Stator & Rotor Assy.	182	22005	1	Battery cover

34	16005	1	Generator fan	183	22010	1	Battery
35	16101	1	Stator cover	184	13030	1	Brush assy.
36	16100	1	Stator Assy.	185	13040	1	Voltage regulator
37	14201	1	Stripe, fuel tank				
38	14200	1	Fuel tank				
39	14302	1	Fuel filter				
40	14303	1	Packing ring				
41	14300	1	Fuel filler cap comp				

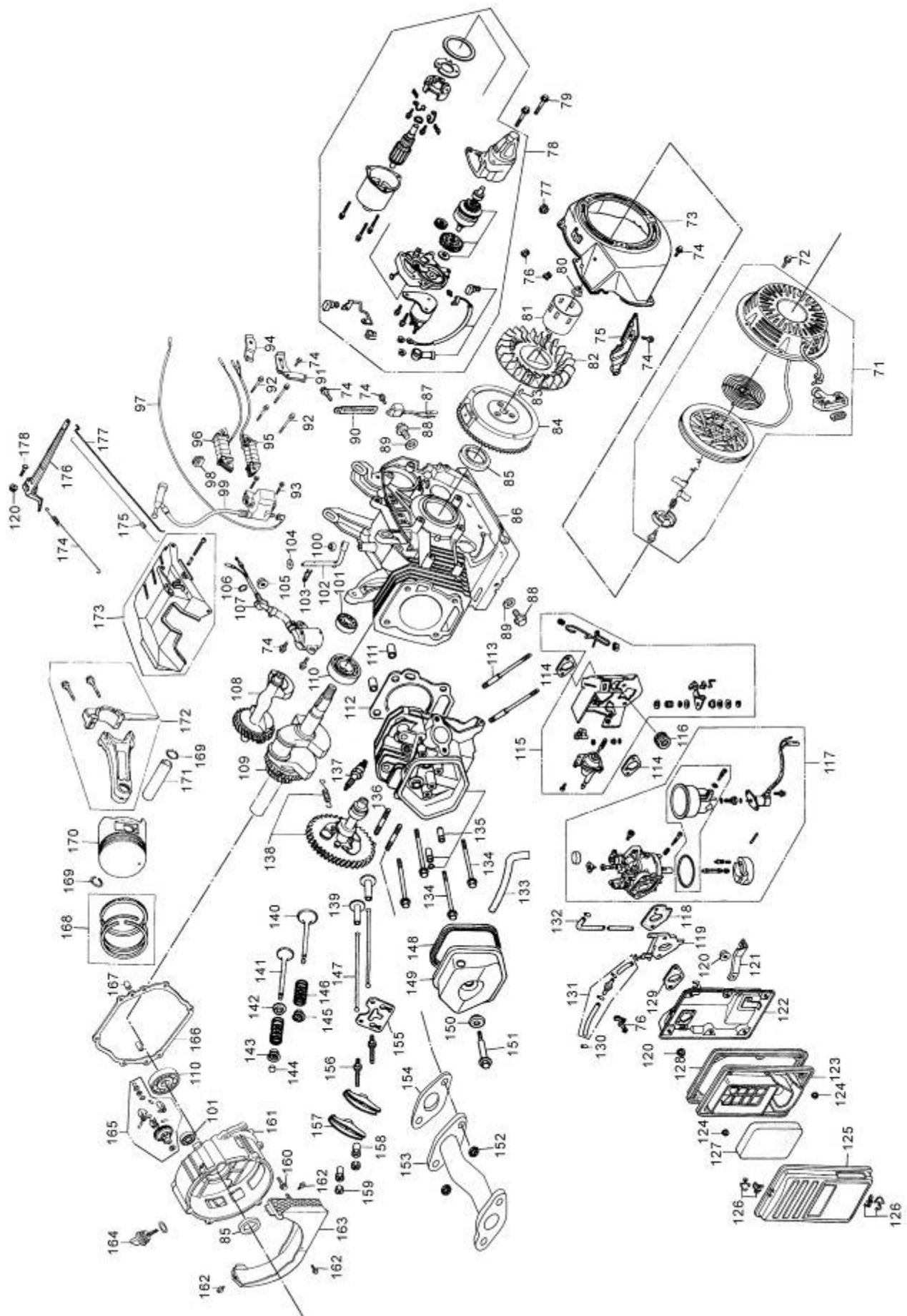

Item	Part	Qty	Description	Item	Part	Qty	Description
71	21100	1	Starter comp, recoil	112	11219	1	Casket, cylinder head
72	GB5787-86	3	Flange bolt M6×8	113	11218	2	Bolt head, 8×106
73	12310	1	Fan, cover comp	114	23008	2	Packing, air cleaner
74	GB5787-86	13	Flange bolt M6×12	115	22000	1	Stay assy. Manual choke
75	19003	1	Shroud comp	116	12012	1	Grommet fender
76	12302	3	Clip. Wire darkness	117	23000	1	Carburetor assy.
77	12302	1	Grommet drain hole	118	23002	1	Packing, carburetor
78	21000	1	Start motor	119	23001	1	Insulator, carburetor
79	GB5789-86	2	Flange bolt M8×35	120	GB6177-86	4	Flange nut M6
80	GB6177-86	1	Flange nut M16	121	12006	1	Stay, air cleaner
81	19005	1	Pulley, starter	122	12005	1	Case comp, air cleaner
82	19001	1	Fan, cooling	123	12004	1	Separator, air cleaner
83	GB/T 99-88	1	Key	124	GB6177-86	6	Flange nut M5
84	81200	1	Flywheel comp	125	12007	1	Cover comp, air cleaner
85	12215	2	Oil seal, 35×52×8	126	12008	2	Clip, air cleaner ware
86	12200	1	Crank case assy.	127	12003	1	Element, air cleaner
87	87500	1	Amplifier	128	12010	1	Seal, air cleaner
88	12203	2	Bolt, drain lug	129	23003	1	Packing, insulator
89	12217	2	Washer, drain lug	130	23011	4	Clip, tube
90	87601	1	Clip, wire	131	23006	1	Valve, dashpot check assy.
91	21012	1	Protect board A	132	91009	1	Tube, fuel φ45×165
92	GB5789-86	4	Flange bolt M6×30	133	12001	1	Tube, breather
93	GB5789-86	2	Flange bolt M6×25	134	GB5789-86	4	Flange bolt M10×80
94	21011	1	Protect board B	135	11250	1	Head comp, cylinder
95	21000	1	Coil assy. excitation	136	11217	2	Bolt head, M8×34
96	22000	1	Coil assy. charge (10A)	137	11202	1	Plug, spark
97	81102	1	Cord stop switch	138	15100	1	Camshaft assy.
98	81103	1	Grommet cord	139	15002	2	Lifter, valve
99	81100	1	Coil assy. ignition	140	11208	1	Valve, IN.
100	12216		Oil seal, 8×14×5	141	11209	1	Valve, EX.
101	GB/T276-94	2	Radial ball bearing (6202)	142	11216	1	Seat, valve spring
102	12208	1	Shaft, governor arm	143	11212	1	Retainer, EX. Valve spring
103	12212	1	Pin, lock, 10mm	144	11213	1	Rotator, valve

104	12209	1	Washer, 8.2×17×0.8	145	11211	1	Retainer, IN. Valve spring
105	GB6177-86	1	Flange nut M10	146	11206	2	Spring, valve
106	12221	1	O-ring,14mm	147	15001	2	Rod, push
107	12200	1	Switch assy. oil level	148	11241	1	Exhaust piper
108	13200	1	Weight, balancer	149	11240	1	Cover comp, head
109	13000	1	Crankshaft comp	150	11243	1	Washer comp head cover
110	GB/T276-94	2	Radial ball bearing (6207)	151	11242	1	Bolt, head cover
111	12220	2	Pin, dowel, 12×20	152	GB6175-86	2	Nut M8
153	13200	1	Pipe comp EX.				
154	13202	1	Casket (B) EX. Pipe				
155	11215	1	Plate, push rod guide				
156	11214	2	Bolt, pivot				
157	11205	2	Arm, valve rocker				
158	11204	2	Nut, Arm, valve rocker				
159	11206	2	Nut, pivot adjusting				
160	GB5789-86	7	Flange bolt M8×40				
161	12100	1	Crankcase cover				
162	GB5789-86	3	Flange bolt M5×10				
163	12301	1	Fan cover				
164	121102	1	Cap assy. oil filler				
165	12230	1	Governor kit				
166	12214	1	Packing, case cover				
167	12213	2	Pin, dowel, 8×12				
168	13100	1	Ping set assy. piston				
169	13105	2	Clip, piston pin				
170	13101	1	Piston				
171	13104	1	Pin, piston				
172	13106	1	Connecting rod assy.				
173	17220	1	Control assy.				
174	17001	1	Spring, governor				
175	17002	1	Spring, throttle return				
176	17004	1	Arm, governor				
177	17003	1	Rod, governor				
178	17005	1	Bolt, governor arm				
