



POWERHORSE®

Owner's Manual

M166111G

ITEM NUMBER: 166111
SERIAL NUMBER:

Instructions for Installation/Set-up, Operation, Servicing, & Storage

Portable, Outdoor Use-Only, Gasoline Generator

166111 - 1800 Watt Continuous (2200 Watt Surge) Capacity

Can be used to power individual appliances plugged directly into the generator's outlets, or as a back-up connection to a building's power supply (via a professionally installed UL-approved transfer switch).

⚠ WARNING

READ and UNDERSTAND this manual completely before using the generator! Failure to properly set up, operate, and maintain this generator could result in *serious injury or death* from *carbon monoxide poisoning, electric shock, fire/explosion, or burns*. In particular, be aware of the following hazards:

CO Poisoning

Generators give off carbon monoxide, a poisonous gas that can kill you. You CANNOT smell it, see it, or taste it.

- ONLY run generator OUTDOORS and AWAY from building air intakes. NEVER run generator inside any enclosed or semi-enclosed spaces, including homes, basements, garages, sheds, boxes, RVs, boats or pick-up truck beds. These spaces can trap poisonous gases, EVEN if you run a fan or open windows.
- Install carbon monoxide alarms inside nearby structures/buildings (battery-operated, or plug-in with battery backup).

Electric shock / Electrocution

- High voltage electricity from generator can kill. DO NOT operate in wet locations. Be sure generator is properly grounded. Use only UL-listed, outdoor-rated grounded extension cords of proper size.
- NEVER plug the generator directly into a wall outlet. ANY connection to a building's electrical system MUST ISOLATE THE GENERATOR FROM UTILITY POWER via a UL-approved transfer switch installed by a licensed electrician. Otherwise, back feed from the generator into the power grid could kill utility workers.

Fire / Explosion

- DO NOT overload generator (per rated capacity), and OPERATE ONLY in an area with adequate cooling ventilation so engine does not overheat. Exhaust can be extremely hot. Keep muffler at least 7 feet from all combustible objects.
- All fuels are flammable. Never fuel a running or hot engine. Never pump fuel directly into generator at gas station – use approved container to transfer fuel. Ensure there are no fuel leaks, and keep sources of sparks and flames away.
- ALWAYS keep a fire extinguisher rated “ABC” nearby.

STOP!

CHOOSE THE RIGHT GENERATOR FOR YOUR NEEDS. See the “Power load Planning & Management” section of this manual to determine your power load requirements and then compare to the generator's rated capacity.

INSPECT COMPONENTS: Closely inspect to make sure no components are missing or damaged. See the “Unpacking & Delivery Inspection” section for instructions on whom to contact to report missing or damaged parts.

ARRANGE FOR PROFESSIONAL INSTALLATION of a transfer switch if you will be connecting the generator to your building's electrical system. See the “Installation/Initial Set-Up” section for more information about this requirement.

Any Questions, Comments, Problems, or Parts Orders
Call Powerhorse Product Support 1-866-443-2576

Hazard Signal Word Definitions





	<p>This is the safety alert symbol. It is used to alert you to potential personal injury hazards. Obey all safety messages that follow this symbol to avoid possible injury or death.</p>
	<p>DANGER (red) indicates an imminently hazardous situation which, if not avoided, will result in death or serious injury.</p>
	<p>WARNING (orange) indicates a potentially hazardous situation which, if not avoided, could result in death or serious injury.</p>
	<p>CAUTION (yellow) indicates a potentially hazardous situation which, if not avoided, may result in minor or moderate injury.</p>
	<p>CAUTION (yellow) used without the safety alert symbol indicates a potentially hazardous situation which, if not avoided, may result in property damage.</p>

fig01453

Table of Contents

Hazard Signal Word Definitions	2
About Your Generator	4
Specifications	6
Safety Label Locations	7
Machine Component Identification	10
Power Load Planning & Management	12
Installation / Initial Set-Up:	
1. Unpacking & Delivery Inspection.....	14
2. Planning the Power Load.....	14
3. Set-up as a PORTABLE or BUILDING BACK-UP Power Source	15
4. Selecting a Suitable Site	18
5. Grounding the Generator.....	20
Operation:	
1. General Safety Rules for Operation	21
2. Preparing for Operation.....	24
3. Starting the Engine	27
4. Checking Generator Output.....	28
5. Connecting Loads.....	29
6. Stopping the Engine	29
7. Storage & Exercise	30
Maintenance & Repair	32
Troubleshooting	34
Summary of Important Safety Information for Operation	35
Engine Operation	39
Engine Troubleshooting	45
Engine Specifications	46
Engine Electrical Diagram	47
Exploded Views	48
Wheel Kit Assembly	54

About Your Generator

Thank you for purchasing your Powerhorse portable generator!

About Your Generator

This engine-driven, portable generator is designed to provide up to 2200Watts of electrical power (1800 watts continuous, 2200 watts surge).

It can supply power:

1. As a portable power source. You can plug appliances directly into the generator's electrical outlets.
2. As a back-up, standby power source for a building. A licensed electrician can connect the generator to your building's electrical system via the installation of an **UL-approved transfer switch**. (See the "Installation & Initial Set-up" section of this manual to learn more about specific requirements and precautions relating to wiring the generator to your building's electrical system.)

You must select a generator adequately sized for your power needs. You need to determine the power needs of all the appliances/tools you wish to power at the same time and choose a generator rated to provide at least that power level. See the "Power Load Planning & Management" section of this manual to determine your specific power load requirements and then compare them to this generator's rated capacity. You must not overload the generator. Overloading will cause damage to the generator and attached electrical devices, and may also result in fire.

Be sure to read about site selection and grounding requirements for running this generator. More detailed information can be found in the "Installation & Initial Set-up, Steps 5 & 6" of this manual.

Contact Powerhorse Product Support at 1-866-443-2576 with questions about optional accessories or to order.

Read this Manual

WARNING

Improper use or maintenance of this generator can result in *serious injury or death* from *carbon monoxide poisoning, electric shock/electrocution, fire/explosion, or burns*.

Read this manual completely before using the generator and follow all instructions and safety rules.

You must follow all instructions and safety precautions presented throughout this manual. A summary of important safety information can be found at the end of the manual. Keep this manual for reference and review.

About Your Generator (cont'd)

Proper preparation, operation, and maintenance will result in operator safety, as well as best performance and long life of the generator. For detailed engine operation and maintenance information, always refer to the engine Owner's Manual furnished with the generator.

Powerhorse is constantly improving its products. The specifications outlined herein are subject to change without prior notice or obligation. The purchaser and/or user shall assume liability for any modification and/or alterations of this equipment from original design and manufacture.

Before using, the user shall determine the suitability of this product for its intended use and assumes liability therein.

Contact Powerhorse Product Support at 1-866-443-2576 for any questions about the appropriate use of this generator.

Warranty Registration

Please fill in the warranty registration information and have it on hand when you call in on a warranty claim or replacement parts.

**ATTENTION:
All Rental Companies and Private Owners who loan this
equipment to others!**

All persons to whom you rent/loan this generator must have access to and read this manual. Keep this owner's manual with the generator at all times and advise all persons who will operate the machine to read it. You must also provide personal instruction on how to safely operate the generator and remain available to answer any questions a renter/borrower might have.

Specifications

Item Number	#166111
Maximum Output	2200 Watts (W)
Continuous Output	1800 Watts (W)
Voltage	120/240 Volt (V)
Phase	Single phase (4-wire)
Frequency	56.5 - 63.3 Hertz (Hz)
Power Factor	1.0 p.f.
Total Harmonic Distortion	less than 5%
Engine	208cc
Engine Speed	3750 RPM
Fuel Type	Unleaded gasoline
Fuel Capacity	3.9 gallons (15 L)
Oil Capacity	0.53 US quarts (0.5 L)
Starting Method	Recoil
120 V Receptacles	2 - 20 Amp (A) duplex (NEMA 5-20R)
Circuit Breakers	1-8 Amp (A) thermal, push to reset 1-18 Amp (A) thermal, push to reset
Dimensions	
Length	24" (cm)
Width	18" (cm)
Height	19" (cm)
Dry Weight	93 lb. (kg)

Safety Label Locations

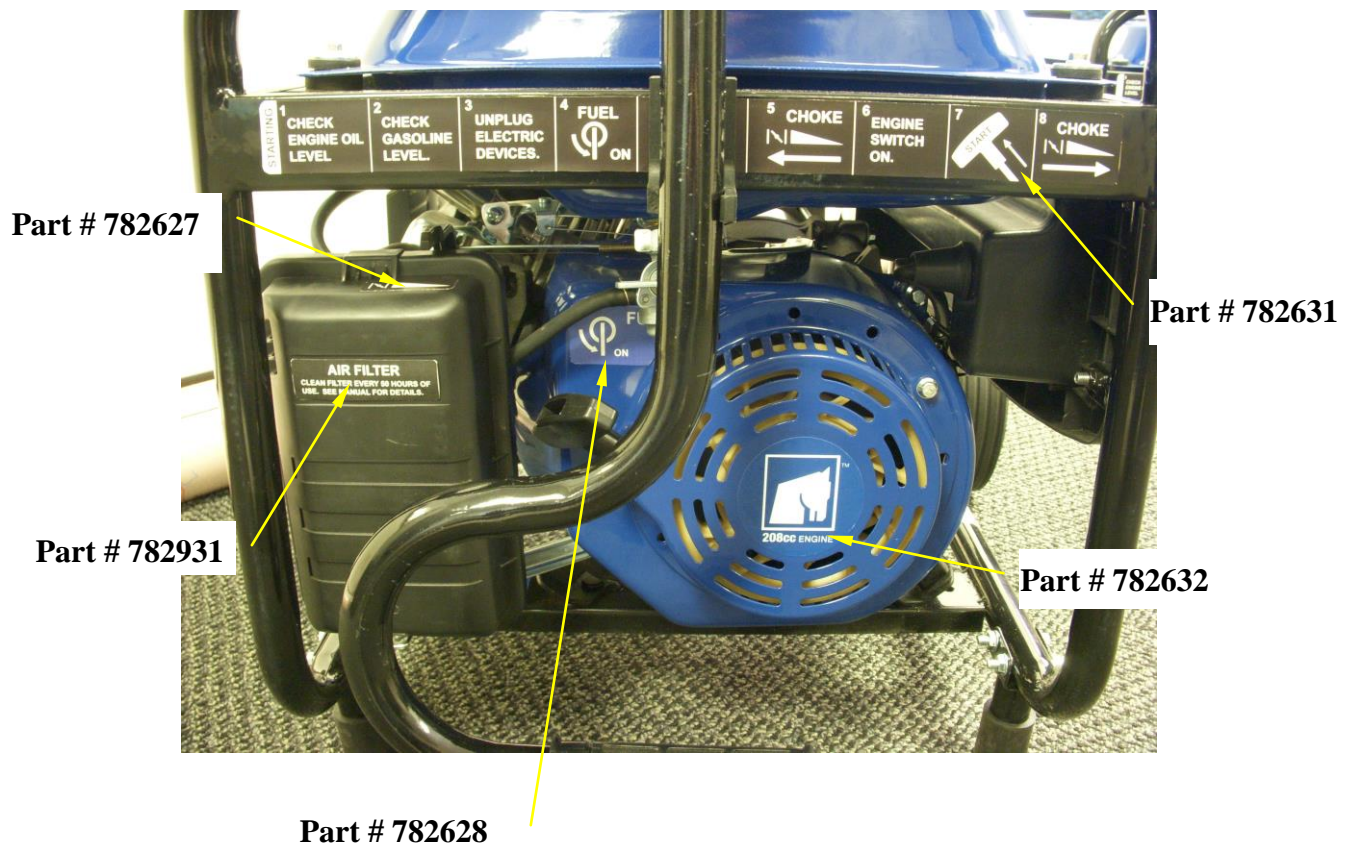

Safety Label Locations

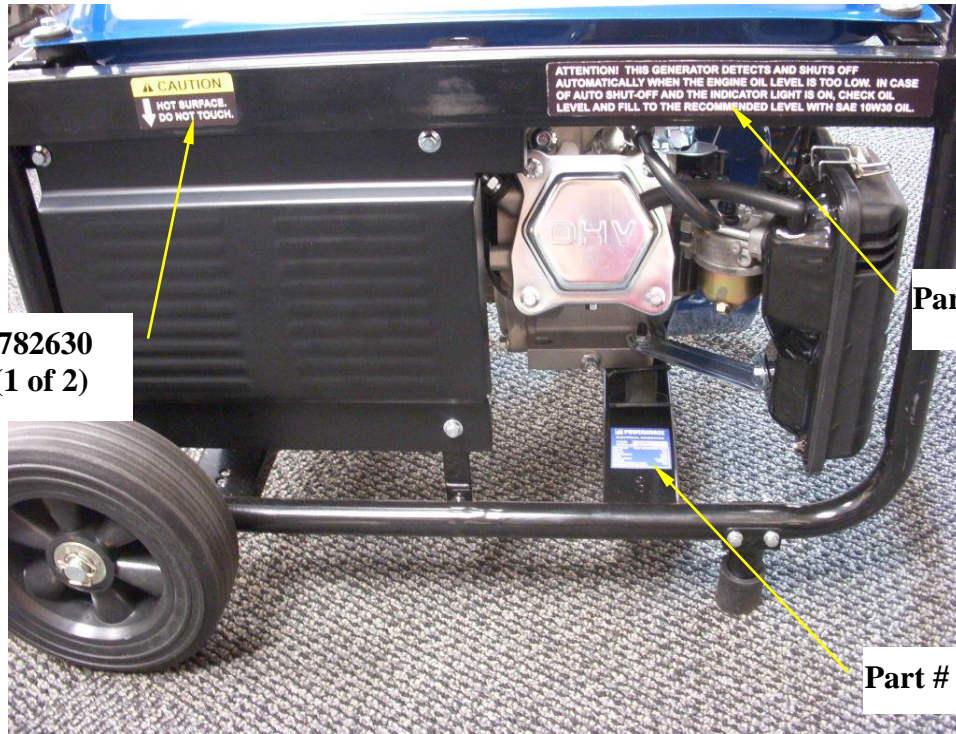

Part # 782630
(1 of 2)

Part # 782633

Part # 782634



Part # 782630
(2 of 2)

Safety Label Locations

Always make sure safety labels are in place and in good condition. If a safety label is missing or not legible, order new labels or unsafe operation could result.

To order replacement safety labels, call Powerhorse Product Support at 1-866-443-2576.

1 CHECK ENGINE OIL LEVEL
Part # 782627 45mm x 15mm

2 CHECK GASOLINE LEVEL
Part # 782628 60mm x 30mm

3 UNPLUG ELECTRIC DEVICES
Part # 782628 60mm x 30mm

4 FUEL
Part # 782629 60mm x 30mm

5 CHOKE
Part # 782630 60mm x 30mm

6 ENGINE SWITCH ON
Part # 782630 60mm x 30mm

7 START
Part # 782630 60mm x 30mm

8 CHOKE
Part # 782630 60mm x 30mm

FUEL
Part # 782628 60mm x 30mm

10W30 OIL
Part # 782629 60mm x 30mm

CAUTION
HOT SURFACE DO NOT TOUCH.
Part # 782630 60mm x 30mm

CAUTION
HOT SURFACE DO NOT TOUCH.
Part # 782630 60mm x 30mm

ATTENTION! THIS GENERATOR DETECTS AND SHUTS OFF AUTOMATICALLY WHEN THE ENGINE OIL LEVEL IS TOO LOW. IN CASE OF AUTO SHUT-OFF AND THE INDICATOR LIGHT IS ON, CHECK OIL LEVEL AND FILL TO THE RECOMMENDED LEVEL WITH SAE 10W30 OIL.
Part # 782633 210mm x 30mm

AIR FILTER
CLEAN FILTER EVERY 2 HOURS OF USE. SEE MANUAL FOR DETAILS.
Part # 782931 70mm x 20mm

POWERHORSE ELECTRICAL GENERATOR
Part # 782634 45mm x 50mm

208CC ENGINE
Part # 782632 rev A Ø65mm

12VDC
Part # 782635 95mm x 45mm

AC 120V
Part # 782414 rev A 438.2mm x 57.2mm

LOW OIL WARNING
Part # 782414 rev A 438.2mm x 57.2mm

POWERHORSE 2200
Part # 782410 466mm x 134mm

POWERHORSE 2200
Part # 782414 rev A 438.2mm x 57.2mm

POWERHORSE 2200
Part # 782414 rev A 438.2mm x 57.2mm

⚠ DANGER

Using a generator indoors CAN KILL YOU IN MINUTES. Generator exhaust contains carbon monoxide. This is a poison you cannot see or smell.

NEVER use inside a home or garage. EVEN IF doors, windows, and vents are open. Only use OUTSIDE and far away from windows, doors, and vents.

Electric Shock/ Electrical Hazard
High voltage electricity from generator can kill. NEVER plug generator into any wall outlet. ANY connection to a building's electrical system MUST BE MADE AT THE GENERATOR FROM UTIL. POWER via a transfer switch. Be sure generator is properly grounded. Use only outdoor-rated, grounded extension cords of adequate length. DO NOT operate in wet locations.

Fire/Explosion Hazard
Fuel is flammable and explosive. Exhaust is very hot. Overloading the generator can cause fire. LPNG hookup must be completed by certified gas technician. NEVER fuel a running or hot engine. Ensure there are no fuel leaks before starting. Keep sources of sparks and flames away. Clean up fuel spills immediately. Keep muffler at least 7 feet from all combustible objects. DO NOT operate generator in enclosed spaces. OPERATE ONLY with adequate cooling ventilation so engine does not overheat. ALWAYS keep a fire extinguisher nearby.

Read Owners Manual completely before using. Serious injury or death can result if safety instructions are not followed.

Part # 782554 rev A
279.4mm x 73mm

Machine Component Identification

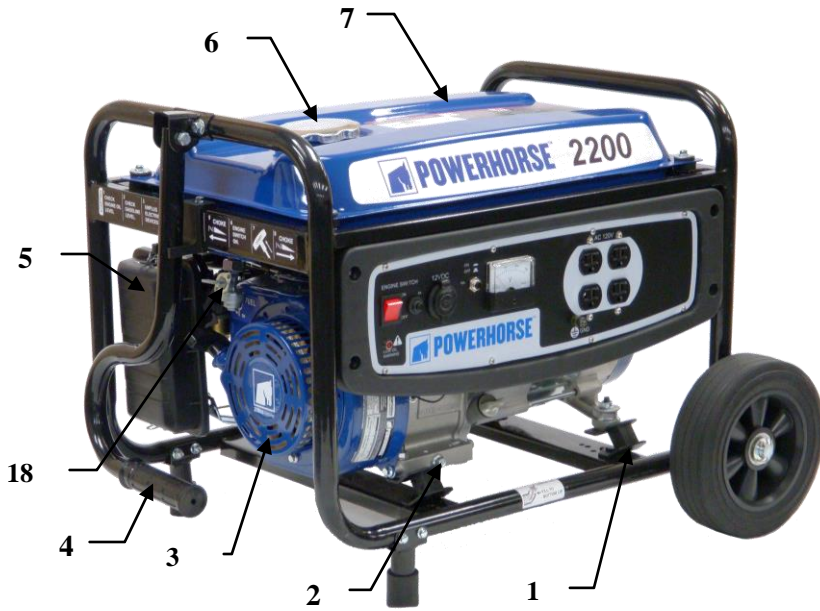

Ref.	Description	Ref.	Description
1	Vibration Isolation Mount	10	Low Oil Warning
2	Oil Drain Plug	11	Engine Switch
3	Recoil	12	Circuit Breaker
4	Handle	13	12VDC Supply
5	Air Cleaner	14	Circuit Breaker
6	Gas Cap	15	Voltmeter
7	3.9 Gallon Gas Tank	16	120V, 20A Duplex Receptacle
8	Generator Head	17	Grounding Post
9	Muffler	18	Fuel Shut Off

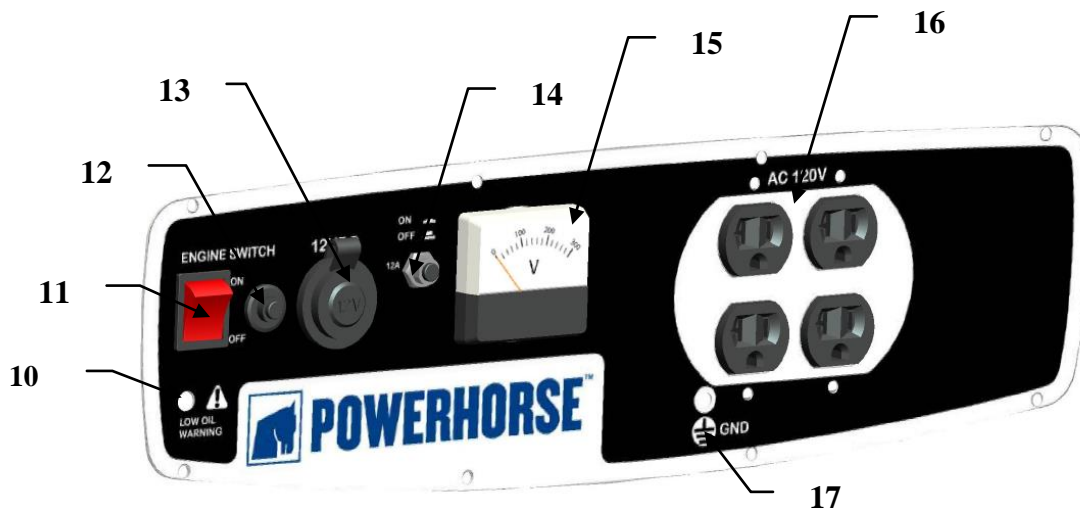

Machine Component Identification

REFERENCE GUIDE

Reference 1 – Vibration Isolation Mount	The engine and generator head are mounted on rubber cylinders that absorb most of the engine vibration. This feature eliminates the tendency of the machine to “walk” which is common in engine-powered equipment.
Reference 2 – Oil Drain Plug	Refer to your engine manual for oil change recommendations.
Reference 3 – Recoil	Grasp firmly when starting engine.
Reference 4 – Handle	Pivot to move the generator.
Reference 5 – Air Cleaner	Refer to your engine manual for air cleaner care.
Reference 6 – Gas Cap	The gas cap is extra large, creating a large hole for refilling and a comfortable grip.
Reference 7 - Gas Tank	Large tank allows for extended run capabilities. Always allow room for gasoline expansion by not filling the gas tank completely.
Reference 8 - Generator Head	The electricity producing part of the generator.
Reference 9 - Muffler	This generator is equipped with a quiet style muffler. The muffler is designed to allow moisture (condensation) to drain from the bottom of the canister. Always check for loose fasteners
Reference 10 – Low Oil Warning	Lamp turns on if oil is low.
Reference 11 – Engine Switch	On / Off for power to engine for starting.
Reference 12 - Circuit Breaker	Circuit breakers protect against electrical overloads.
Reference 13 – 12VDC Supply	12 volts for charging battery and operating other 12 volt devices.
Reference 14 – Circuit Breaker	Circuit breakers protect against electrical overloads.
Reference 15 – Voltmeter	Voltmeter needle should be in appropriate voltage range during all generator load conditions.
Reference 16 - 120V, 20A Duplex Receptacle	The generator has a control panel with two duplex (two receptacles in a common housing) receptacles. Each duplex is a 120 volt (V) 20 amp (A) straight blade receptacle, National Electrical Manufacturer’s Association (NEMA) number 5-20R. This receptacle accepts NEMA plug numbers 5-15P and 5-20P.
Reference 17 – Grounding Post	Used to prevent electrical shock.
Reference 18 – Fuel Shut Off	The engine is equipped with an ON-OFF valve located on the left side of the recoil. ALWAYS keep this valve closed when the generator is not in use.

Power Load Planning & Management

⚠ WARNING

NEVER exceed the rated wattage capacity of your generator.
 OVERLOADING may cause SERIOUS DAMAGE to the generator and attached electrical devices, and may result in fire.

Your generator **MUST BE SIZED PROPERLY** to provide both the running and starting (surge) wattage of the devices you will be powering. Before using your generator, determine the running and starting wattage requirements of all the electrical devices you will be powering simultaneously. The sum of the running and starting wattages of the devices being powered must not exceed the continuous output rating of your generator. (The continuous output rating of your generator is listed in the “Specifications” section of this manual.) Note that:

- Devices without electric motors such as light bulbs, radios, and televisions have the same running and starting wattage.
- Devices with electric motors such as refrigerators, compressors, and hand tools typically require a starting wattage that is 3 to 5 times greater than the running wattage.

The running and starting wattage requirements are often listed on a device’s nameplate. If wattage is not given on the device’s nameplate, the wattage may be calculated by multiplying the nameplate voltage by nameplate amperage, $\text{Watts} = \text{Volts} \times \text{Amps}$.

Example conversion to watts:

$$120 \text{ Volts} \times 5 \text{ Amps} = 600 \text{ Watts}$$

If only the running voltage is given on the nameplate for a device with an electric motor, the starting wattage can be approximated to be three to five times the running wattage.

Estimates for the running wattage requirements for common devices are listed in **Table 1** below. Guidance for starting wattages is provided in the table’s footnotes.

Table 1

Device	Running Watts	Device	Running Watts
Air conditioner (12,000 BTU)	1700 (a,b)	Jet pump	800 (a)
Battery charger (20 Amp)	500	Lawn mower	1200
Belt sander (3")	1000	Light bulb (100 Watt)	100
Chain saw	1200	Microwave oven	700
Circular saw (6½")	2000 (a,b)	Milk cooler	1100 (a)
Coffee maker	1800 (a,b)	Oil burner on furnace	300
Compressor (1 HP)	1400 (a,b)	Oil-fired space heater (140,000 Btu)	400
Compressor (¾ HP)	1800 (a)	Oil-fired space heater (85,000 Btu)	225
Compressor (½ HP)	1400 (a)	Oil-fired space heater (30,000 Btu)	150
Curling iron	700	Oven	4500
Dishwasher	1200	Paint sprayer, Airless (1/3 HP)	600 (a)
Edge trimmer	500	Paint sprayer, Airless (handheld)	150
Electric nail gun	1200	Radio	200
Electric range (1 element)	1500	Refrigerator	600 (b)
Electric skillet	1250	Slow cooker	200

Power Load Planning & Management (cont'd)

Device	Running Watts	Device	Running Watts
Furnace fan (1/3 HP)	1200 (a)	Submersible pump (1-1/2 HP)	2800 (a)
Freezer	800 (b)	Submersible pump (1 HP)	2000 (a)
Hair dryer	1200	Submersible pump (1/2 HP)	1500 (a)
Hand drill (1")	1100	Sump pump	600 (a)
Hand drill (1/2")	875	Table saw	2000 (a)
Hand drill (3/8")	500	Television	500
Hand drill (1/4")	250	Toaster	1000
Hedge trimmer	450	Vacuum cleaner	250
Home computer	150	VCR	70
Impact wrench	500	Water Heater	3000
		Weed trimmer	500

(a) Hard-starting motors require 3-5 times the rated running watts

(b) For extremely hard to start loads such as air conditioners and air compressors, consult the equipment dealer to determine maximum wattage

To calculate the running and starting wattage requirements for the devices you will be powering, follow these steps:

1. Make a list of all electrical devices you will be powering at the same time with the generator.
2. List the greater of the running or starting wattage next to each device as obtained from the devices' nameplate or **Table 1**. If only the running wattage for a device with an electric motor is known, the starting wattage can be estimated to be at least 3 times the running wattage.
3. Add the wattages for all devices on your list. This total must be lower than the continuous output rating of your generator.

Example:

Device to be Powered	Greater of Starting/Running Wattage
Light Bulb	75 W
Refrigerator – 18 Cu. Ft.	1600 W
Microwave	700 W
Window AC	1800 W
Sump pump (1/3 hp)	2100 W
Total	6275W

In this example, the generator must have a continuous output of at least 6275 W in order to power all of the devices simultaneously.

STAGGERING LOADS

You can increase the number of devices your generator can power by staggering the load on the generator. For example, you could alternately power your refrigerator and air conditioner for limited periods of time -- powering only one of the devices at a time and never powering both at the same time.

Installation/Initial Set-Up

There are a number of important steps required to set up your generator for initial use. These steps are:

Steps for Installation / Initial Set-Up

- 1. Unpacking & delivery inspection.**
- 2. Planning the power load to stay within the generator's rated capacity.**
- 3. Setting up generator for the type of power generation you need:**
 - a. portable power source, or**
 - b. connected to a building as a back-up power source.**
- 4. Selecting a site for using the generator.**
- 5. Grounding.**
- 6. Battery installation (electric start models only).**

Each of these steps is discussed in detail below:

1. Unpacking & Delivery Inspection

You should inspect the generator immediately after you receive delivery.

See the "Machine Component Identification" section of this manual for a diagram of the generator and its components.

- If you have *missing* components, contact Product Support at 1-866-443-2576.
- If you have *damaged* components, contact the freight company that delivered the unit and file a claim.

2. Planning the Power Load

Plan your power load so that you do not exceed the generator's rated capacity.

See the "Power Load Planning & Management" section of this manual to review how to plan and manage power loads for the generator.

Installation/Initial Set-Up

3. Set-up either as a BUILDING BACK-UP or PORTABLE Power Source

This generator is designed to provide up to 2200 watts of electrical power. It can supply electricity in two ways:

1. **As a backup, standby power source for a building.** For this application, you must arrange for a licensed electrician to connect the generator to your building's electrical system via the installation of an UL-approved transfer switch. The transfer switch must be installed in accordance with building electrical code and guidelines supplied by your power company.
2. **As a portable power source.** You can plug appliances or tools directly into the generator's electrical outlets.

Specific requirements for each are given below.

Note: Regardless of whether you use your generator as a back-up power source connected to a building or as a portable power source, you must not overload the generator. Overloading may cause serious damage to the generator and attached electrical devices.

Using as a Back-up Power Source for a Building

Contact a licensed electrician to install a UL-approved transfer switch if you want to use your generator as a back-up power source for a building.

What does a transfer switch do? It:

- a) Safely connects the generator to your building's electrical system by isolating your generator from your utility company's power lines, AND
- b) Connects your generator to a critical subset of your building's circuits that are needed for emergency power needs.

If your generator will be connected to your building's electrical system, it **MUST ALWAYS** be isolated from the utility power grid with a *UL-approved transfer switch installed by a licensed electrician* in compliance with all applicable building and electrical codes, and in accordance with guidelines supplied by your power company.

DANGER:

A transfer switch must be installed in order to isolate your generator from the utility power grid. If your generator is **NOT** properly isolated from the utility system, serious hazards will arise:

- ◆ When your generator is running, it's output will back feed into the utility power line and transformer that are normally used to provide you with power. The transformer will step up the current to the normal line voltage. An unsuspecting utility line worker working on what he thinks is a deactivated line could be electrocuted.
- ◆ If your generator is connected (running or not) when utility power is restored, your generator will be destroyed. It could also explode or cause fire.

In addition to isolating your generator from the utility system, the transfer switch connects your generator to a limited set of circuits in your building that have been chosen as critical to operate during a power outage.

Installation/Initial Set-Up

The generator cannot power your entire home -- you must work with the installing electrician to determine which devices/appliances you wish to power during an outage. The electrician can help you determine which circuits and devices can be powered simultaneously without overloading the generator.

(See the previous section of this manual entitled “**Power Load Planning & Management**” for more information on load application and selection.)

Using as a Portable Power Source

When using the generator as a portable power source, you can plug electric devices and appliances directly into the generator’s electrical outlets.

There is only one kind of electrical outlet on the generator:

1. Two 120 Volt, 20 Amp duplex straight-blade receptacles (NEMA 5-20R duplex receptacles compatible with NEMA 5-20P or 5-15P mating plugs).



(See more technical detail about these receptacles and their associated circuit breakers in the “Machine Component Identification” section of this manual.)

- ◆ Make sure you plug each electrical device/appliance into the correct generator outlet based on the device’s plug configuration and voltage/ampere rating. Never exceed the ampere rating of an outlet.

Installation/Initial Set-Up

- ◆ Extension cords may be used to power devices that are located at a distance from the generator. However, use only UL-listed, outdoor-rated, grounded extension cords of the proper size. Use Table 2 below to choose an adequately sized extension cord according to the amperage of the device being used and the length of the cord.

Table 2

Current/Power		Maximum Extension Cord Length			
Amps at 240V	Load (watts)	#10 Ga. Cord	#12 Ga. Cord	#14 Ga. Cord	#16 Ga. Cord
10	2400	250'	150'	100'	75'
20	4800	125'	75'	50'	25'
30	7200	60'	35'	25'	10'
40	9600	30'	15'	10'	*
50	12000	15'	*	*	*

⚠ WARNING:

Use of under sized extension cords can cause electric shock, fire, or damage to connected devices.

- ◆ All extension and appliance cords must be in good condition and not worn, bare, frayed, or otherwise damaged.

⚠ WARNING:

Use of damaged electric cords can cause electric shock or fire.

Note: If an extension cord becomes hot to the touch, it is overloaded or damaged and must be replaced.

Northern Tool is NOT responsible for damage or injury resulting from customer use of inadequate extension cords.

Installation/Initial Set-Up

4. Select a Suitable Site

Before using the generator, you must select a suitable **OUTDOOR** location for installation and operation. This location should meet all of the criteria listed below.

⚠ WARNING:

You must choose a suitable site for operating your generator to avoid equipment damage and/or injury and possible death from carbon monoxide poisoning, electric shock, or fire. Choose a site that meets all of the criteria specified.

Dry, level surface	<p>The generator should be positioned on a dry, firm, level surface.</p> <p>Ensure that the generator sits level and will not slide or shift during operation. If applicable, block the generator's wheels to prevent sliding and shifting.</p>
Outdoors only – dangerous carbon monoxide exhaust	<p>⚠ WARNING: Carbon monoxide poisoning hazard</p> <p>The exhaust from your generator contains carbon monoxide (CO), a poisonous gas that can kill. You cannot smell it, see it, or taste it. <i>Carbon monoxide exhaust is given off whether you are using gasoline, natural gas, or propane as the fuel source to power the generator.</i></p> <p>Follow the directions below for choosing a location to operate your generator in order to avoid carbon monoxide poisoning.</p> <p>The location you choose to operate the generator must be OUTDOORS and away from all air intakes:</p> <ul style="list-style-type: none"> • Never run the generator inside any closed or semi-enclosed spaces (even if outdoors), including homes, garages, basements, sheds, or boxes. <i>These spaces can trap poisonous gases, even if you run a fan or open windows.</i> • Place the generator so that the exhaust fumes will not be directed towards people or building air intakes. • Ensure that working, battery-operated or battery back-up carbon monoxide alarms are used in any dwelling/structure that is in close proximity to the running generator. • Note that this generator is NOT designed or approved for use in vehicles or marine applications. Never run the generator inside RVs or other vehicles, on boats, or on pick-up truck beds. <p>⚠ WARNING:</p> <p>Never attempt to attach ductwork to the muffler system to allow for installation inside an enclosure. This could cause hot air deflection, heat build-up, and increased exhaust back-pressure, resulting in possible exhaust leakage or damage to the generator.</p>
Adequate cooling ventilation	<p>The generator needs adequate, unobstructed flow of air to allow for proper cooling of engine and generator head.</p> <p>⚠ WARNING:</p> <p>Heat build-up from inadequate ventilation can result in fire, posing a serious risk to nearby persons and structures.</p> <ul style="list-style-type: none"> • Situate so there is adequate clearance around generator to allow for cooling airflow so that heat does not build up.

Installation/Initial Set-Up

	<ul style="list-style-type: none"> • Never place the generator immediately adjacent to a building or other structure – allow at least 7 feet clearance. • Do not run the generator in close proximity to other heat-generating equipment, such as another generator. The combined heat that is generated may raise air temperature in the immediate area and there will not be adequate cooling ventilation. • Do not allow debris to accumulate and block airflow. • Do not operate with a tarp, blanket, or cover surrounding the generator.
<p>No wet conditions</p>	<p>Choose a location where the generator will NOT be exposed to rain, snow, or direct sunlight. Exposure to water can cause electric shock.</p> <p>You <i>may</i> operate the generator under an outdoor, canopy-like structure of heat-resistant material that is open on all sides. Make sure that all parts of canopy are at least 7 feet from exhaust, and allow for adequate clearance above generator so that heat does not build up.</p>
<p>Hot exhaust clearance</p>	<p>The exhaust gas from your generator is extremely hot and can cause combustible materials to catch on fire.</p> <ul style="list-style-type: none"> • Make sure your generator’s exhaust system is at least 7 feet from all combustible materials and buildings/structures. • Equip the engine with a spark arrestor if the generator will be used near any ignitable forest, brush, or grassy land. (See the “Specifications” section of this manual to determine if your generator is already equipped.) Make sure you comply with applicable local, state, and federal codes. • Keep a fire extinguisher rated “ABC” nearby. Keep it properly charged and be familiar with its use.
<p>Away from dust/dirt</p>	<p>Do not use the generator in extremely dusty or dirty conditions. Excessive dust and dirt can cause premature failure of the machine.</p>
<p>Hearing protection</p>	<p>Generators can produce noise levels of up to 95 dB in close proximity, which can be dangerous to human hearing with prolonged exposure.</p> <p>Hearing protection may be required for persons working within 15-20 feet of the running generator for an extended period of time.</p> <p> WARNING: Never attempt to attach ductwork to the muffler system to lower noise levels. This could cause hot air deflection, heat build-up, and increased exhaust back-pressure, resulting in possible exhaust leakage or damage to the generator.</p>

Installation/Initial Set-Up

5. Grounding the generator

Always ensure the generator is properly grounded to prevent electrical shock.

You must always ground the generator by the following method when using the generator as a portable electrical source:

- 1) Drive a $\frac{3}{4}$ " or 1" copper pipe or rod into the ground close to the generator. The pipe/rod must penetrate moist earth – the depth required will be dictated by local soil conditions. Consult with an electrician.
- 2) Connect an approved ground clamp to the pipe.
- 3) Run a 10 gauge wire from the clamp to the generator grounding post located on the rear of the generator head.
- 4) Do not connect the generator grounding post to a water pipe or a ground used by a radio system.

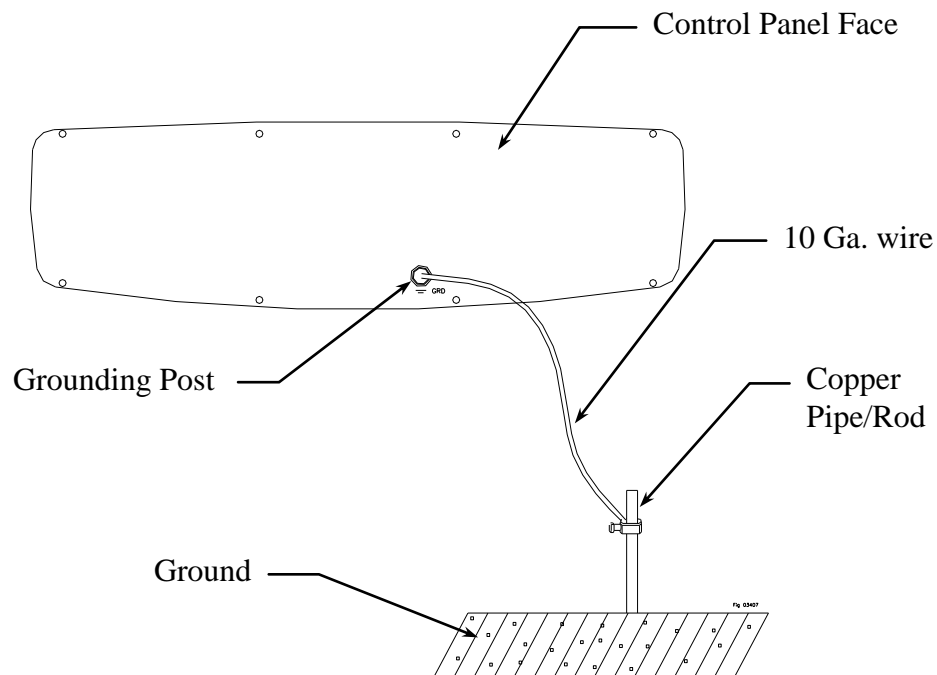

If a licensed electrician installs the generator with a connection to your building's electrical circuit for use as a back-up power system, grounding may alternatively be completed through the building's grounding system. Ask your electrician. If the generator is not grounded through your building's electrical system, follow the procedure above.

⚠ WARNING:

Operating the generator when it is not properly grounded can result in electrical shock.

Operation

Once you have set up your generator for use, it is time to start your generator. The following are the procedures necessary for safe, successful operation of your generator.

Operation Procedures

1. **General Safety Rules for Operation**
2. **Preparing for Operation**
3. **Starting the Engine**
4. **Checking Generator Output**
5. **Connecting Electrical Loads (Portable Power Generation)**
6. **Stopping**
7. **Storage & Exercise of Generator**

Each of these procedures is discussed in detail below:

1. General safety rules for operation

Before starting the generator, review the following general safety rules for operation:

 **WARNING:**

Failure to follow safety rules may result in serious injury or death to the operator or bystanders.

- **Know proper use/how to stop.** Be thoroughly familiar with proper use of the equipment and all generator controls, output receptacles, and connections. Know how to stop the generator quickly if needed (see “Operation, Step 6 - Stopping the Engine”).
- **Instruct operators.** The generator owner must instruct all operators in safe generator set-up and operation. Only trained adults should set up and operate the generator – Do not let children operate.
- **Intended use.** Carefully read about and understand the intended use of this generator. Do not use for other purposes, as unforeseen hazards or equipment damage may result.
- **Under the influence.** Never operate, or let anyone else operate, the generator while under the influence of alcohol, drugs, or medication.
- **Safety equipment / controls.** Do not operate the generator unless all safety covers, guards, and barriers are in place and in good working order, and all controls are properly adjusted for safe operation.
- **Damaged.** Do not operate the generator with damaged, missing, or broken parts.
- **Modifications.** Do not modify the generator in any way. Modifications can create serious safety hazards and will also void the warranty.
- **Engine speed.** Never attempt to modify the engine speed setting. The engine speed is preset at 3600 RPM for safe and optimal performance of the generator. If speed needs adjusting, it must be done by factory-authorized personnel.
- **External fuel sources.** Never attempt to connect external gasoline/diesel sources in order to increase engine run time. Larger tank at pressure or higher elevation will cause gasoline to leak from carburetor during operation. Fire or explosion could result.

Operation

- **Malfunction during operation.** Immediately turn off the generator if any of the following conditions arise during operation:
 - Excessive change in engine speed, slow or fast
 - Overheating in load connecting devices
 - Sparking or arcs from generator
 - Loss of electrical output
 - Receptacle damage
 - Engine misfire
 - Excessive vibration
 - Flame or smoke
 - Abnormal noise
- **Adjusting / repairing.** Always turn off generator and remove spark plug(s) or spark plug wire(s) before working on the generator to prevent accidental starting. Always discharge the capacitor before working on the generator head to prevent electrical shock. (See Maintenance & Repair section of this manual for instructions on how to do this.)
- **Carbon monoxide poisoning.** The running engine gives off carbon monoxide, a poisonous gas that can kill you. You CANNOT smell it, see it, or taste it. Follow all instructions for site selection and positioning the generator, and avoid inhaling the exhaust. If you start to feel sick, dizzy, or weak while using the generator, shut off the engine and get to fresh air RIGHT AWAY. See a doctor. You may have carbon monoxide poisoning.
- **Other exhaust dangers.** This product contains or emits chemicals known to the State of California to cause cancer, birth defects or other reproductive harm. Avoid inhalation of exhaust.
- **Wet conditions.** Do not operate the generator or handle any electrical equipment while standing in water, while barefoot, while hands are wet or while in the rain or snow. Electric shock may result.
- **Ground fault circuit interrupter.** Always use a ground fault circuit interrupter (GFCI) protected extension cord (or outlet, if generator is equipped) in damp or highly electrical conductive areas and on construction jobsites to prevent electrical shock.
- **Avoid contact.** Avoid contact with bare wires, terminals, connections, etc. while the unit is running.
- **Electric shock accident.** If an electric shock accident occurs, immediately shut down the source of electrical power. If this is not possible, attempt to free the victim from the live conductor. Avoid direct contact with victim. Use a nonconducting implement, such as a dry rope or board, to free the victim from the live conductor. Apply first aid and get immediate medical help.
- **Smoking/sparks.** Never smoke near the running generator, and never operate near sources of sparks or flames.
- **Hot muffler.** Never touch hot muffler, hot exhaust manifold, or engine cooling fins. Exhaust and engine parts can be very hot and will burn you.
- **Moving parts.** Keep hands, feet, and apparel away from drive belts, fans, and other moving parts. Never remove any drive belt or fan guard while the unit is operating.

Operation

Static electricity and filling the gasoline tank:

Static electricity can initiate from ungrounded gasoline tanks or containers, from flowing gasoline, and from persons carrying a static electric charge

Static electricity can explosively ignite gasoline vapors that are present during the fueling process, resulting in serious burns to nearby persons. To avoid static electricity while fueling, certain steps must be followed before and during the fueling process in order to minimize and safely dissipate static charge build-up:

- ***Touch a grounded metal object before starting.*** Always dissipate static charge from your body before beginning the fueling process by touching a grounded metal object at a safe distance away from fuel sources.
- ***Use a portable container to fill tank.*** Never fill the generator's gas tank directly from the fuel pump – the generator's tank is not grounded and the high velocity flow of gasoline from a fuel pump can cause static electric build-up. Use an approved portable container to transfer gasoline to the generator's tank.
- ***Fill container on the ground.*** Never fill the portable gas container while it is sitting inside a vehicle, trailer, trunk, or pick-up truck bed. ALWAYS place container on the ground to be filled.
- ***Keep nozzle in contact with container.*** Keep nozzle in contact with the portable container at all times while filling. Manually control the flow of gasoline; do NOT use the nozzle's lock-open device.
- ***Use a portable container made of metal or conductive plastic.*** It will dissipate charge to ground more readily.

About static electricity and fueling

Many common objects can accumulate and retain a static electric charge. Objects made of non-conductive materials (e.g. plastics) easily accumulate and retain static electric charge, as can objects made of conductive material (e.g. metal, water) if they are not electrically grounded. The static electric charge on an object, such as a human body or plastic fuel tank/container, can reach as high as several thousand volts!

A static electric spark can be generated if the static electric charge stored on an object “jumps” to another, less charged object. Such a spark can ignite invisible gasoline vapors that are present during fueling situations.

Typical sources of static electric hazards during fueling

The following objects can accumulate a static electric charge and cause an ignition spark in typical fueling situations:

- 1) **Ungrounded tanks/containers.** Any ungrounded fuel tank or container can accumulate a static electric charge as a result of contact with other objects or friction during transportation. This static electricity can discharge as a spark to the grounded gasoline dispenser nozzle, as the nozzle is first brought close to the tank/container at the beginning of the fueling process.
- 2) **Flowing gasoline.** Most people are not aware that gasoline accumulates static electric charge while flowing through a hose or pipe. This charge then transfers to and accumulates in the gas tank or container that is being filled. The total amount of charge accumulation depends on the amount of gas pumped into the container, the speed with which it is pumped, and whether or not the tank/container is grounded. If sufficient static electric charge accumulates in the fuel tank or container during the fueling process, the tank/container may discharge a spark to the grounded gasoline dispenser nozzle.
- 3) **Persons.** A person dispensing the gasoline can carry a static electric charge on their body, typically resulting from contact with their car seat or electronics. The static electricity can discharge as a spark between that person's hand and either the grounded dispenser nozzle or the fuel tank opening.

Operation

2. Preparing for Operation

Position generator	<p>Position generator in accordance with the instructions given in “Installation & Initial Set-up, Step 4: Select a Suitable Site” of this manual.</p> <p>Operate outside only, on dry, level ground with adequate clearance and ventilation.</p> <p>⚠ WARNING: Carbon monoxide poisoning hazard Generators give off carbon monoxide exhaust, a poisonous gas that can kill. You CANNOT smell it, see it, or taste it. ONLY run generator OUTDOORS and away from air intakes. NEVER run generator inside any enclosed or semi-enclosed spaces, including homes, garages, basements, sheds, boxes, pick-up truck beds, RVs, or boats. These spaces can trap poisonous gases, EVEN if you run a fan or open windows. <i>Carbon monoxide exhaust is given off whether you are using gasoline, natural gas, or propane to power the generator.</i></p>
Ground generator	<p>Make sure the generator is grounded in accordance with instruction given in “Installation & Initial Set-up, Step 5: Grounding the Generator” of this manual.</p> <p>⚠ WARNING: Electric shock hazard Always ensure generator is properly grounded to prevent electrical shock.</p>
Perform scheduled maintenance as needed	<p>Make sure that any regular maintenance has been performed as prescribed in this manual in the “Maintenance & Repair” section.</p> <ol style="list-style-type: none"> 1. Refer to the engine owner’s manual for engine maintenance instructions. 2. Make sure battery is charged. Charge as needed according to your battery manufacturer’s instructions.
Check/add oil	<p>Check the oil level using the dipstick and add oil as needed.</p> <p>Using a funnel, add oil up to the FULL mark on the dip stick with the recommended oil type for your engine and expected ambient conditions. (See engine Owner’s Manual for oil type and capacity, and more detailed oil check/fill instructions.)</p> <p>⚠ WARNING: Burn hazard Never open oil port while engine is running. Hot oil can spray over face and body.</p> <p><i>Notes:</i></p> <ul style="list-style-type: none"> ○ <i>Low oil shutdown feature prevents the generator from starting without sufficient oil.</i> ○ <i>Engine is shipped <u>without</u> oil. You must add oil before first use.</i> <p>IMPORTANT: Under long, continuous-run operating conditions, be prepared to:</p> <ul style="list-style-type: none"> • Check engine oil level every time you refuel the engine. • Change oil after the first 20 operating hours, and at least every 100 operating hours thereafter, or as directed in engine owner’s manual.
Check/fill gasoline tank	<p>Check the gasoline level in the generator’s tank. If needed, fill tank with fresh unleaded gasoline from a portable container, after first reading the warnings and instructions below.</p>

Operation

WARNING: Gasoline fire/explosion hazard

Gasoline is highly flammable and explosive. Heat, sparks, and flames can ignite gasoline vapors, which can become widespread during fueling. A flash fire and/or explosion could result and cause serious injury or death. Use extreme care when handling gasoline. Carefully follow all the instructions in this section to avoid the following conditions which could result in gasoline ignition:

- gas vapor collection inside enclosures
- static electric sparks
- sparks from electric wiring, batteries, or running engines
- sources of heat (such as a hot engine or exhaust)
- open flames, including pilot lights

1) Before starting, review the following general safety precautions for fueling:

- a) Never pump gasoline directly into the generator's gas tank at a gas station – high velocity flow from the pump could result in a static electric build-up in the generator's tank. Always use a portable container to fill the tank. *See warning box about static electric spark hazards below.*
- b) Fill gasoline tank **OUTDOORS** – never indoors.
- c) Stay away from all sources of heat, sparks, and flames. Do not smoke.

2) Turn generator engine off and allow to cool for at least two minutes before removing gas cap.

Note: A running or still-hot engine is hot enough to ignite fuel.

Remove generator gasoline cap.

Add gasoline through the fill opening:

- Use only a UL-approved portable gasoline container to transfer the gasoline to the generator's tank. Follow the safety warning and instructions below for avoiding static electric sparking.
- Do NOT overfill the gasoline tank. Allow at least 1/2 inch of empty space below the fill neck to allow for fuel expansion.

WARNING: Static electric spark hazard

A static electric spark can explosively ignite gasoline vapor, resulting in a flash fire that could cause serious injury or death.

To avoid static electric sparking while filling the gasoline tank, **the following steps must be followed to minimize and safely dissipate static electric charge build-up before and during the fueling process:**

- Always dissipate static charge from your body before beginning the fueling process by touching a grounded metal object at a safe distance from fuel sources.
- Never fill the generator's gas tank directly from the fuel pump – the generator's tank is not grounded and high velocity flow from the pump can cause static electricity build-up. Use an approved portable container to transfer gas to the generator's tank.
- Never fill the portable gas container while it is sitting inside a vehicle, trailer, trunk, or pick-up truck bed. **ALWAYS** place container on the

Operation

	<p>ground to be filled.</p> <ul style="list-style-type: none"> • Keep nozzle in contact with portable container while filling. Manually control the flow of gasoline; do NOT use the nozzle's lock-open device. • A portable container made of metal or conductive plastic is preferred because it dissipates charge to ground more readily. <p>5) Clean up gasoline spills /splashes immediately.</p> <ul style="list-style-type: none"> • If possible, move the generator away from spilled gasoline on the ground. • Wipe up spilled gasoline, and wait 5 minutes for excess gasoline to evaporate before starting engine. • Gasoline soaked rags are flammable and should be disposed of properly. • If gasoline is spilled on your skin or clothes, change clothes and wash skin immediately. <p>6) Replace gasoline cap securely before starting engine.</p> <p>7) Store extra gasoline in a cool, dry place in an UL-approved, tightly sealed container.</p> <p>IMPORTANT: For continuous operation, be prepared to check and refuel the engine on a regular basis. A tank of gasoline should last about 10.5 hours under 50% load.</p>
<p>Inspect Fuel System / Check for Leaks</p>	<p>Inspect fuel system & check for leaks BEFORE starting generator. Do not start generator until all needed repairs have been completed.</p>
<p>Personal Protection</p>	<p>1) Hearing can be damaged from prolonged, close-range exposure to the type of noise produced by this generator. The use of ear plugs or other hearing protection device is recommended for persons working within 15-20 feet of the running generator for an extended period of time.</p> <p>2) Loose or dangling apparel can become entangled in moving parts. Metal jewelry can conduct electricity. Never wear jewelry or loose-fitting clothing when starting or operating the generator.</p>

Operation

3. Starting the Engine

After you have completed the pre-start checklist procedures, you are ready to start the engine.

To start the engine:

- 1) Disconnect all loads to the generator.
- 2) Turn the gasoline line valve to the ON position.
- 3) For cold engine, move choke lever to full choke position. To restart a warm engine, move choke lever to half choke or to RUN position.
- 4) Start the engine:
 - a) Using electric start –
 - i) Turn the engine key switch to the START position and hold it there until the engine starts.
NOTE: *If the engine fails to start after 5 seconds, release key and wait 10 seconds before attempting to start again. Cranking the electric starter for more than 5 seconds continuously can overheat and damage the starter motor.*
 - ii) Release the key when the engine starts.
 - b) Using recoil start –
 - i) Turn the engine key switch to the ON position.
 - ii) Pull the starter grip lightly until you feel resistance, then pull the starter cord out briskly and rapidly.
 - iii) Allow starter cord to return slowly.
- 5) When engine starts, move choke lever to RUN position.
- 6) Under long, continuous-run operating conditions, be prepared to:
 - a) Check and refuel the engine on a regular basis. A tank of gas should last about 10.5 hours under 50% load.

⚠ WARNING:

A running engine is hot enough to ignite fuel. Never add fuel or remove gas cap if engine is running or still hot. Let cool at least 2 minutes.

- b) Check engine oil level each time you refuel.

- c) Change oil after the first 20 operating hours, and at least every 100 operating hours thereafter, as directed in the engine owner's manual.

⚠ WARNING:

Never open oil port while engine is running. Hot oil can spray over face and body.

Operation

4. Checking Generator Output

Although the speed of the engine was carefully adjusted at the factory so that the generator produces the proper voltage and frequency, **output voltage should be checked periodically to ensure the generator is working properly before connecting loads to the generator.**



WARNING:

The generator must be run at the correct speed in order to produce the proper electrical voltage and frequency. Failure to do so could result in damage to equipment powered by the generator and possible injury to the individual.

Output voltage should be checked with a portable voltage meter:

1. Start engine and allow to warm up for five minutes. Do not connect any loads.
2. Use voltage meter to check output voltage at the generator's outlets/receptacles.
3. Measured voltage should be within the following ranges:
 - a. 120V +/- 10% at 120V receptacles.
 - b. 240V +/- 10% at 240V receptacles.
4. If measured voltage is not within the specified range, have generator adjusted by factory authorized personnel. Do not attempt to adjust the engine speed yourself.

NOTE: Slight variation in voltage/speed with changing electrical loads

All engines have a tendency to slow down when a load is applied. When electrical loads are connected to the generator, the engine is more heavily loaded and as a result the speed drops slightly.

This slight decrease in speed, together with the voltage drop within the generator itself, results in a slightly lower voltage when the generator is loaded to its full capacity than when it is running with no load. Additionally, there may be small brief surges and drops in voltage as motors connected to the generator cycle on or off.

The slight variation has no appreciable effect in the operation of motors, lights, and most appliances.

Operation

5. Connecting Loads

You will want to be careful when connecting loads so as not to overload the generator, especially if you are powering devices with motors that require a higher starting power load.

Instructions are provided below for connecting loads when you are using the generator:

- As a portable power source
- Connected to a building as a back-up power source



WARNING:

Do not overload generator. Make sure that combined starting and running loads do not exceed rated capacity of generator. Overloading the generator can cause damage to the generator and attached electrical devices, and may result in fire.

Using as a Portable Power Source

Connect electrical loads one at a time according to the following instructions:

1. Allow engine to reach operating speed by allowing it to warm up for approximately 5 minutes before connecting electrical devices.
2. After engine is warmed up, begin by connecting the items that require the highest wattage first. The recommended sequence is as follows:
 - a. Connect items with motors such as refrigerators, freezers, air conditioners, or small hand tools, one at a time. Let each motor stabilize before connecting the next device.
 - b. Connect any lights you are planning on powering.
 - c. Connect voltage sensitive equipment such as electronics via surge protectors. Plug devices such as TV's, computers, and microwaves into a UL listed voltage surge protector, then plug the surge protector into the generator.

Using as a Back-up Power Source for a Building

Each transfer switch installation will be unique.

Proper instructions for how to safely bring the generator online with the building's electrical system should be provided by the installing electrician, who should also provide personal instruction to the owner/operator.

Failure to follow the proper procedure as provided by the electrician could expose persons to the hazards noted above.

6. Stopping

Stop the engine using the following steps:

1. Disconnect all loads to the generator.
2. Turn engine key switch to OFF position.
3. Turn gasoline line shut-off valve to OFF position.
4. Remove key from starter to prevent accidental starting of engine.

Operation

7. Storage & Exercise

When you are finished using the generator, you must:

- Disconnect all loads
- Shut off fuel supply
- Store the generator properly
- Plan on exercising the engine regularly unless the generator is prepared for long-term storage.

Detailed instructions are provided below.

Disconnect loads & turn off fuel supply	<p>When you are finished using the generator, disconnect all loads and turn off fuel supply:</p> <ol style="list-style-type: none"> 1. Make sure all devices that were connected to the generator's outlets have been disconnected. 2. Check to be sure gasoline line shut-off valve is in OFF position.
Cool engine before storing	<p>Let engine cool for at least five minutes before storing. A hot engine can be a fire hazard.</p>
Choose a storage location	<p>Store the generator in a location that is:</p> <ul style="list-style-type: none"> ○ Clean and dry ○ Away from sources of heat, open flames, sparks, or pilot lights, even if the generator's fuel tank is empty. Residual fuel in the tank could ignite. ○ Away from extreme high or low temperatures. <p><u>Note:</u> Do not store with battery charger always connected. Batteries that are over-charged can boil themselves dry and produce excessive amounts of hydrogen, an explosive gas.</p>
Prevent accidental starting	<p>Remove key from starter (for electric start engines) and secure key in a safe location, or remove spark plug(s) in order to ensure the generator cannot be started accidentally in a storage location or by untrained persons.</p>
Exercise generator every 4 weeks	<p>The generator should be exercised regularly.</p> <p>At least every four weeks, start the engine and let it run for 10 to 15 minutes with a small load plugged in, such as a lamp or fan.</p> <p>Monthly exercising of the generator will:</p> <ul style="list-style-type: none"> ○ Dry out any moisture that has accumulated in the windings. If left, this moisture can cause corrosion in the winding. ○ Ensure that the unit is operating properly should it be needed in an emergency.
Perform regular maintenance	<p>Perform periodic maintenance as directed in this manual to keep the generator in safe working condition.</p>

Operation

Prepare engine for long term storage if needed

If you will not be able to exercise the generator regularly, you must prepare the engine for long term storage to prevent gum deposits from forming and causing malfunction of the engine.

Prepare engine for long term storage by:

- **Removing all gasoline** from the tank and carburetor
- OR
- **Adding fuel stabilizer** to the gasoline (following manufacturer's instructions)

Fuel stabilizer steps:

1. Ensure gasoline tank is full.
2. Add fuel stabilizer to fuel tank.
3. Run engine at least 10 minutes after adding stabilizer to allow it to enter the fuel system.
4. Shut off engine
5. Disconnect spark plug wire and remove spark plug
6. Add one teaspoon oil through spark plug hole
7. Place rag over spark plug hole and turn starter (or pull the recoil) a few times to lubricate the combustion chamber.
8. Replace spark plug, but do not reconnect the spark plug wire.

Maintenance & Repair

Inspect and maintain your generator as specified below in order to keep it in safe and optimal working order. Follow all safety rules and recommended maintenance steps.

WARNING

ALWAYS shut off the engine, disconnect the spark plug(s) and discharge the capacitor before cleaning, adjusting, or servicing the generator. Make sure all guards and shields are replaced before using.

Note: The generator head is a brush style and requires maintenance. The bearing is a heavy-duty sealed ball bearing which requires no maintenance or lubrication.

Maintenance & Repair	
Follow safety rules	<p>Read and follow these safety rules whenever you will be servicing the generator:</p> <ul style="list-style-type: none"> • Turn off generator. Always turn off generator and remove spark plug(s) or spark plug wire(s) before working on the engine or generator to prevent accidental starting. • Replace guards. Make sure all guards and shields are replaced after servicing the generator. • Repair. Major service, including the installation or replacement of parts, should be performed only by a qualified electrical service technician. Obtain factory approved parts from Powerhorse Product Support at 1-866-443-2576. • Replacement parts. If a part needs replacement, only use factory approved repair parts. Replacement parts that do not meet specifications may result in a safety hazard or poor operation of the generator and will void the warranty.
Perform engine maintenance	<p>Perform engine maintenance as specified in the engine owner’s manual. Engine maintenance items include:</p> <ol style="list-style-type: none"> 1. Changing oil and oil filter 2. Air filter check/replacement 3. Spark plug cleaning and replacement 4. Fuel filter check/replacement 5. Fuel tank cleaning.
Check receptacles	<p>Check receptacles before each use to make sure they are not cracked or broken. If a receptacle is cracked or otherwise damaged, do not use until replaced with an authorized factory part. Using cracked or damaged receptacles can be both dangerous to the operator and destructive to the equipment.</p>
Inspect fuel system / check for leaks	<p>Inspect the fuel system and check for leaks on a regular basis.</p> <ol style="list-style-type: none"> 1) Inspect the entire fuel system. Look for: signs of leaks or deterioration, chafed or spongy fuel hose, loose connections, loose or missing fuel hose clamps, damaged gasoline tank, or defective gasoline shut-off valve.
Check GFCI (if equipped)	<p>Once a month, test the Ground Fault Circuit Interrupter (GFCI) to protect against electrical shock due to failure of the GFCI. (Only for those models equipped with GFCI – See the “Specifications” section.)</p> <p><u>To test the GFCI:</u></p> <ol style="list-style-type: none"> 1. Depress the TEST button. The RESET button should extend from the receptacle. If the RESET button does not extend, contact Powerhorse for

Maintenance & Repair (cont'd)

	<p>replacement parts.</p> <p>2. Restore power to the GFCI by firmly pressing the RESET button back into the receptacle until an audible click is heard.</p>
Clean & inspect spark arrestor (if equipped)	<p>Clean and inspect the spark arrestor muffler. (Only for those models equipped with a spark arrestor – See the “Specifications” section.)</p> <p>If the engine is equipped with a spark arrestor muffler, clean and inspect it regularly (follow manufacturer’s service instructions). Replace if damaged.</p>
Keep generator clean	<p>Keep generator clean.</p> <p>If dust or debris accumulates on the generator, clean the generator with a damp cloth or soft bristle brush. Do not allow air intakes to become blocked.</p> <p><u>Note:</u> Do not spray generator with a garden hose or pressure washer. Water may enter the generator and cause damage to the rotor, stator, or internal windings.</p>
Recharge and maintain battery (if electric start)	<p>Inspect, recharge, and maintain your battery according to your battery manufacturer’s instructions. (Only for those models equipped with electric start.)</p> <p>Do not store with battery charger always connected. Batteries that are over-charged can boil themselves dry and produce excessive amounts of hydrogen, an explosive gas.</p>

IMPORTANT:

If a part needs replacement, only use parts that meet the manufacturer’s specifications. Replacement parts that do not meet specifications may result in a safety hazard or poor operation of the generator.

Contact Powerhorse Product Support at 1-866-443-2576 for any questions, problems, or parts orders.

Troubleshooting

TROUBLESHOOTING		
<u>Problem</u>	<u>Possible Causes</u>	<u>Possible Remedies</u>
Engine will not start.	<ul style="list-style-type: none"> a) Low oil level. b) Fouled spark plug. c) Out of fuel. d) Engine switch in OFF position. 	<ul style="list-style-type: none"> a) Fill crankcase to proper oil level. b) Clean or replace spark plug. c) Fill fuel tank. d) Place engine switch in ON position.
Voltage too low.	<ul style="list-style-type: none"> a) Engine speed too slow. b) Generator is overloaded. 	<ul style="list-style-type: none"> a) Bring generator to a qualified technician for adjustment. b) Reduce the load. (See Power Load Planning & Mgt. section of this manual.)
Circuit breaker trips.	<ul style="list-style-type: none"> a) Defective load connected to generator. b) Defective receptacle. c) Generator overloaded. 	<ul style="list-style-type: none"> a) Disconnect load. b) Replace receptacle. c) Reduce the load. (See Power Load Planning & Mgt. section of this manual.)
Voltage too high.	<ul style="list-style-type: none"> a) Engine speed too high. 	<ul style="list-style-type: none"> a) Bring generator to a qualified technician for adjustment.
Generator overheating.	<ul style="list-style-type: none"> a) Generator is overloaded. b) Insufficient ventilation. 	<ul style="list-style-type: none"> a) Reduce the load. (See Power Load Planning & Mgt. section of this manual.) b) Make sure there is at least 7 feet of clearance on all sides of generator.
No output voltage.	<ul style="list-style-type: none"> a) Defective load connected to generator. b) Broken or loose wire. c) Defective receptacle. d) Defective stator. e) Defective rotor. f) Circuit breaker tripped. 	<ul style="list-style-type: none"> a) Disconnect load. b) Bring generator to a qualified technician for repair. c) Replace receptacle. d) Bring generator to a qualified technician for repair. e) Bring generator to a qualified technician for repair. f) Reset circuit breaker and reduce loads connected to the generator.
Engine lacks power.	<ul style="list-style-type: none"> a) Generator is overloaded. b) Dirty air filter. 	<ul style="list-style-type: none"> a) Reduce the load. (See Power Load Planning & Mgt. section of this manual.) b) Clean or replace air filter.
Engine shuts down during operation.	<ul style="list-style-type: none"> a) Out of fuel. b) Low oil level. 	<ul style="list-style-type: none"> a) Fill fuel tank. b) Fill crankcase to proper oil level.

Summary of Important Safety Information for Operation

This section provides a summary of the various safety procedures and measures that have been presented throughout the manual. Keep this summary handy and refer to it to refresh your memory about how to safely use your generator.

WARNING

Carefully read and make sure you understand the following safety information before using the generator. Improper use or maintenance of the generator can result in *serious injury or death* from *carbon monoxide poisoning, electric shock, fire/explosion, or burns*.

General

- **Read manual.** Read this Owner's Manual and the engine Owner's Manual completely before attempting to set-up and use the generator. Serious injury or death can result if safety instructions are not followed.
- **Instruct operators.** The generator owner must instruct all operators in safe generator set-up and operation. Do not allow anyone to operate the generator who has not read the Owner's Manual and been instructed on its safe use.
- **Adults only.** Only trained adults should set up and operate the generator. Do not let children operate.
- **Under the influence.** Never operate, or let anyone else operate, the generator while under the influence of alcohol, drugs, or medication.
- **Intended use.** Carefully read about and understand the intended use of this generator. Do not use for other purposes, as unforeseen hazards or equipment damage may result.

Prohibition Against Modifications

Never modify or alter the generator in any way. Modifications can create serious safety hazards and will also void the warranty.

- **Engine speed.** Never attempt to modify the engine speed setting. The engine speed is preset at 3600 RPM for safe and optimal performance of the generator. If speed needs adjusting, it must be done by factory-authorized personnel.
- **Fuel/exhaust system.** Never modify the exhaust system, fuel tanks, or fuel lines. Carbon monoxide poisoning, fire, or explosion could result.
- **Guards.** Do not operate generator unless all guards and cover shields, which prevent access to moving parts and pinch points, are in place. Failure to guard the power transmission mechanisms *may result in serious injury or death*.

Safety – Installation & Set-up

Installation / Initial Set-up Safety

- **Dry, level surface.** Situate generator on a dry, firm, level surface. Ensure generator sits level and will not slide or shift during operation. Block wheels if applicable.
- **Operate OUTSIDE only – dangerous carbon monoxide exhaust!** Generators give off carbon monoxide exhaust, a poisonous gas that can kill. You CANNOT smell it, see it, or taste it. ONLY run generator OUTDOORS and away from building air intakes. NEVER run generator inside homes, garages, sheds, or other semi-enclosed spaces. These spaces can trap poisonous gases, EVEN if you run a fan or open windows. Carbon monoxide is given off whether you are using gasoline, natural gas, or propane to power the generator.
- **No vehicle/marine use.** This generator is NOT designed or approved for use in vehicles or marine applications. Never run the generator inside RVs or other vehicles, on boats, or on pick-up truck beds.
- **Cooling ventilation.** The generator needs adequate, unobstructed flow of air to allow for proper cooling of engine and generator head. Situate so there is adequate clearance around generator to allow for cooling airflow. Do not allow debris to accumulate and block airflow.
- **Grounding.** Always ensure generator is properly grounded to prevent electrical shock. This generator is equipped with a grounding post. Always complete the grounding path from the generator to a copper pipe/rod driven into moist earth to a sufficient depth. Check with an electrician for local grounding requirements. If a

Summary of Important Safety Information for Operation (cont'd)

licensed electrician installs the generator with a connection to your building's electrical circuit for use as a standby power system, grounding will be complete through the building's grounding system.

- **Isolate connection to building's electrical circuit.** Never plug the generator directly into a wall outlet. ANY connection to a building's electrical system MUST ISOLATE THE GENERATOR FROM UTILITY POWER via an UL-approved transfer switch installed by a licensed electrician in compliance with all applicable local building and electrical codes. If the generator is not isolated from the utility power system by such means, generator output will back feed into the utility power grid. This may result in injury or death to utility power workers or others who contact the lines during a power outage. It may also cause the generator to explode or cause fires when utility power is restored.
- **Wet conditions.** Water conducts electricity. Do not operate generator where it is wet. Operate on a dry surface under an open, canopy-like structure.
- **CO alarms.** Ensure that working, battery-operated or battery back-up carbon monoxide alarms are used in any dwelling/structure that is in close proximity to the running generator.
- **Hot exhaust - fires.** Exhaust from engine can be extremely hot and cause fire. Position muffler at least 7 feet from combustible objects during operation.
- **Spark arrestor.** Equip engine with a spark arrestor if generator will be used near any ignitable forest, brush, or grassy land. See the "Specifications" section of this manual to determine if your generator is already equipped. Make sure you comply with applicable local, state and federal codes.
- **Fire extinguisher.** Keep a fire extinguisher rated "ABC" by the National Fire Protection Association nearby. Keep it properly charged and be familiar with its use.

Safety – Before Use

Know how to operate

- **Review safety rules.** Before each use of this generator, review the "Rules for Safe Operation." Failure to follow these rules may result in serious injury or death.
- **Know how to operate.** Be thoroughly familiar with all controls and with the proper use of the equipment. Know how to stop the generator quickly if needed.

Personal protective equipment

- **Hearing protection.** The use of ear plugs or other hearing protection device is recommended for those in close proximity to the generator while it is operating.
- **Loose / dangling.** Loose or dangling apparel can become entangled in moving parts. Metal jewelry can conduct electricity. Never wear jewelry or loose-fitting clothing when operating the generator.

Gasoline Safety

Gasoline is highly flammable and explosive. You can be burned or seriously injured when handling fuel. Use extreme care when handling:

- **Fuel outdoors.** Fill fuel tank outdoors – never indoors. Gasoline vapors can ignite if they collect inside an enclosure. Explosion can result.
- **Use approved container.** Never pump fuel directly into engine at gas station. Static charge can build and ignite fuel. Use an UL approved fuel container to transfer gas to the engine.
- **Running / hot engine.** A running engine is hot enough to ignite fuel. Never add fuel or remove gas cap if engine is running or still hot. Stop the engine and allow to cool at least two minutes before adding fuel.
- **Heat / flames / sparks.** Stay away from sources of heat, flame, or sparks while adding fuel.
- **Don't overfill.** DO NOT overfill the gas tank. Allow at least 1/2 inch of empty space below the fill neck to allow for fuel expansion.
- **Replace cap.** Replace gas cap securely before starting engine.
- **Spills.** Clean up fuel spills immediately. Move generator away from spilled fuel on the ground. Wipe fuel off engine and wait 5 minutes for excess fuel to evaporate before starting engine. Gas soaked rags should be disposed of properly.
- **On skin / clothes.** If gasoline is spilled on your skin or clothes, change clothes and wash skin immediately.

Summary of Important Safety Information for Operation (cont'd)

- **Inspect fuel system.** Check fuel system on a regular basis. Look for signs of leaks, deterioration, chafed or spongy fuel hose, loose or missing fuel hose clamps, damaged fuel tank, or a defective fuel shut-off valve. Do not start generator until needed repairs have been completed.
- **Gasoline storage.** Store gasoline in a cool, dry place in an UL-approved, tightly sealed container.

Safety – During Use

- **Safety equipment / controls.** Always operate the generator with all safety covers, guards, and barriers in place and in good working order, and all controls properly adjusted for safe operation.
- **Know how to stop.** Be thoroughly familiar with proper use of the equipment and all generator controls, output receptacles, and connections. Know how to stop the generator quickly if needed.
- **Damaged.** Do not operate the generator with damaged, missing, or broken parts.
- **Carbon monoxide exhaust.** The running engine gives off carbon monoxide, a poisonous gas that can kill you. You CANNOT smell it, see it, or taste it. If you start to feel sick, dizzy, or weak while using the generator, shut off the engine and get to fresh air RIGHT AWAY. See a doctor. You may have carbon monoxide poisoning.
- **Smoking/sparks.** Never smoke near the running generator, and never operate near sources of sparks or flames.
- **Check output voltage.** Check output voltage to ensure the generator is working properly before connecting loads to the generator. Failure to do so could result in damage to equipment powered by the generator and possible injury to the individual. Do not adjust output speed of engine to change voltage. If voltage is not within specified range, have generator repaired by factory-authorized personnel.
- **Stabilize before connecting loads.** Start generator and let engine stabilize before connecting electrical loads.
- **Do not overload.** Do not overload the generator. Make sure that combined starting and running loads do not exceed rated capacity of generator or damage will result.
- **Protect sensitive electronics.** Some electronic equipment, such as computers and audio/video equipment, can be damaged by small fluctuations in the flow of power. Use a surge suppressor for any voltage-sensitive electronic equipment you will be powering with the generator.
- **Wet conditions.** Do not operate the generator or handle any electrical equipment while standing in water, while barefoot, while hands are wet or while in the rain or snow. Electric shock may result.
- **Ground fault circuit interrupter.** Always use a ground fault circuit interrupter (GFCI) protected extension cord (or outlet, if generator is equipped) in damp or highly electrical conductive areas and on construction jobsites to prevent electrical shock.
- **Electrical cords.** Use only UL-listed, outdoor-rated, three prong extension cords of the proper size. All extension and appliance cords must be in good condition and not worn, bare, frayed, or otherwise damaged. Use of inadequate or damaged electric cords can cause electric shock or fire.
- **Avoid contact.** Avoid contact with bare wires, terminals, connections, etc. while the unit is running.
- **Electric shock accident.** If an electric shock accident occurs, immediately shut down the source of electrical power. If this is not possible, attempt to free the victim from the live conductor. Avoid direct contact with victim. Use a nonconducting implement, such as a dry rope or board, to free the victim from the live conductor. Apply first aid and get immediate medical help.
- **Hot muffler.** Never touch hot muffler, hot exhaust manifold, or engine cooling fins. Exhaust and engine parts can be very hot and will burn you.
- **Moving parts.** Keep hands, feet, and apparel away from drive belts, fans, and other moving parts. Never remove any drive belt or fan guard while the unit is operating.
- **Refueling.** DO NOT refuel the engine until it has cooled at least two minutes.
- **Malfunction during operation.** Immediately turn off the generator if any of the following conditions arise during operation:
 - Excessive change in engine speed, slow or fast
 - Overheating in load connecting devices
 - Sparking or arcs from generator
 - Loss of electrical output
 - Receptacle damage
 - Engine misfire
 - Excessive vibration
 - Flame or smoke
 - Abnormal noise

Summary of Important Safety Information for Operation (cont'd)

- **Adjusting / repairing.** Always turn off generator and remove spark plug(s) or spark plug wire(s) before working on the generator to prevent accidental starting.

Safety – After use

- **Cool engine before storing.** Let engine cool for at least five minutes before storing. A hot engine can be a fire hazard.
- **Shut off fuel supply.** Make sure gasoline shut-off valve is in the OFF position.
- **Prevent accidental starting.** When generator is not in use, remove key from starter (key start engines) and secure in a safe location, or remove spark plug(s) in order to ensure that generator cannot be started in a storage location or by untrained persons.
- **Storage location.** Store the generator in a dry location away from sources of heat, open flames, sparks or pilot lights – such as water heaters, space heaters, furnaces, clothes dryers, or other gas appliances – EVEN IF the generator's gas tank is empty. Residual gasoline could ignite.
- **Exercise regularly.** Exercise generator every four weeks to dry out moisture that accumulates in the windings. If generator cannot be exercised on a regular basis, prepare generator for long term storage.
- **Periodic maintenance.** Perform periodic maintenance as directed in this manual to keep the generator in safe working condition.

Safety - Inspection/Maintenance

Inspect and maintain your generator on a regular basis and repair as needed to keep it in safe working condition:

- **Turn off generator.** Always turn off generator and remove spark plug(s) or spark plug wire(s) before working on the engine or generator to prevent accidental starting.
- **Discharge capacitor.** When the generator is shut down, the capacitor may maintain a charge. Always discharge the capacitor before working on the generator head to prevent electrical shock.
- **Replace guards / shields.** Make sure all guards and shields are replaced after servicing the generator.
- **Replacement parts.** If a part needs replacement, only use parts that meet the manufacturer's specifications. Replacement parts that do not meet specifications may result in a safety hazard or poor operation of the generator and will void the warranty.

Engine Operation (cont'd)

WARNING

BEFORE operating the engine, be sure to read this section of the manual, otherwise injury to personnel or damage to equipment may occur.

Start Up Instructions

Engine Starting Devices

Fuel Valve Lever

When the valve lever is in the ON position, fuel is allowed to flow from the fuel tank to the carburetor. Be sure to return the fuel valve to the OFF position after stopping the engine.

Choke Rod

The choke is used to provide an enriched fuel mixture when starting a cold engine. It can be opened and closed by operating the choke lever manually. Pull the rod out toward CLOSED to enrich the mixture for cold starting.

Engine Switch

Turn the switch ON to run the engine and to stop the engine turn the switch OFF.

Recoil

To start the engine, pull the starter grip lightly until resistance is felt, then pull briskly.

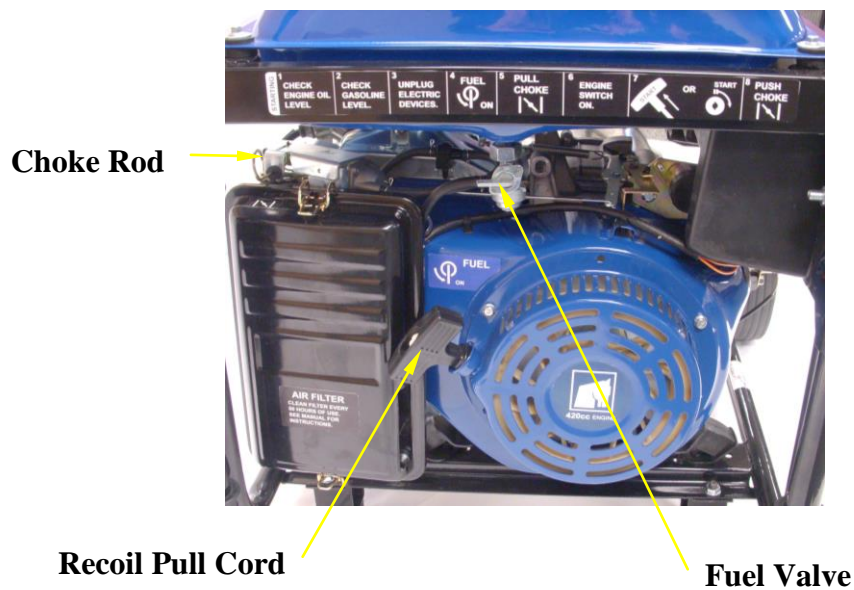

Engine Operation (cont'd)

Engine Oil Recommendations

Caution

- Engine oil is a key factor in deciding the engine's performance. Do not apply engine oil with additives or 2-stroke gasoline oil, as they haven't enough lubrication, which may shorten the engine's service life.
- Check the engine with it stopped on a level ground.
- Due to viscosity variances with regions and temperatures select the correct oil using the chart below.

Engine oil recommended: SAE10W-30

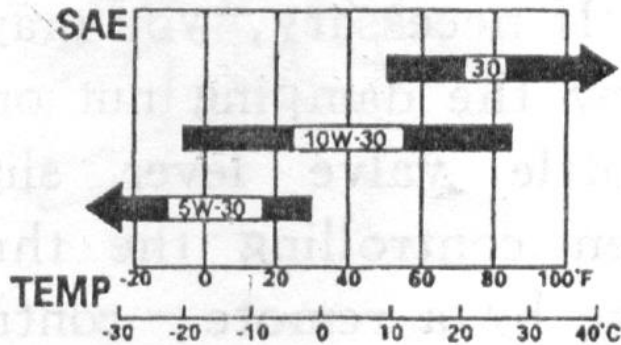

Oil Level Check

1. Ensure that the engine is stopped on a level ground.
2. Remove the dipstick and clean it.
3. Reinsert the dipstick into the oil filler without threading in, and check oil level.
4. If the oil level is too low, add recommended engine oil to the filler neck.
5. Reinstall the dipstick.

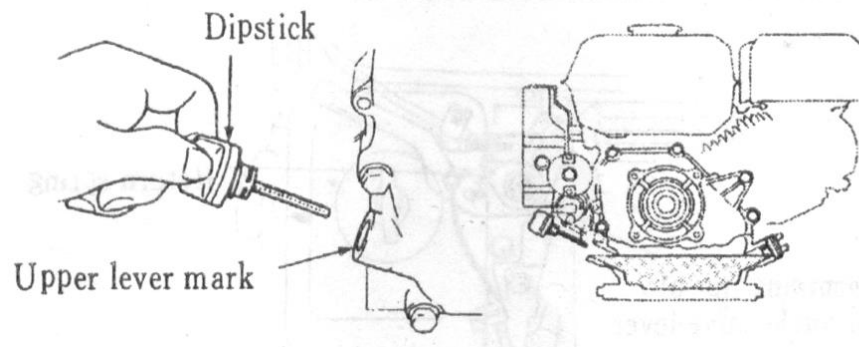

Engine Operation (cont'd)

Maintenance Schedule

Regular Service Period			Before each use	First month or 20 Hrs.	Every 3 months or 50 Hrs.	Every 6 months or 100 Hrs.	Every year or 300 Hrs.
•	Engine Oil	Check level	○				
		Change		○		○	
•	Air filter	Check	○				
		Clean			○(1)		
		Replace					○
•	Spark Plug	Check-adjust				○	
		Replace					○
	Spark arrester	<input type="checkbox"/> lean				○	
•	Idle speed	Check-adjust					○(2)
•	Valve clearance	Check-adjust					○(2)
•	Combustion chamber	Clean	After every 500Hrs. (2)				
•	Fuel tank and filter	Clean				○(2)	
•	Fuel tube	Check	Every 2 years (Replace if necessary) (2)				

•Emission related items.

(1) Service more frequently when used in dusty areas.

(2) These items should be serviced by an authorized generator dealer, unless the owner has the proper tools and is mechanically proficient.

Engine Operation (cont'd)

Spark Plug Removal, Cleaning and Replacement

Spark Plug

Spark plug type: NHSP LD F7TC

Proper spark plug clearance ensures the engine's normal running under no deposit around the spark plug.

- a) Remove the spark plug by means of spark plug wrench.

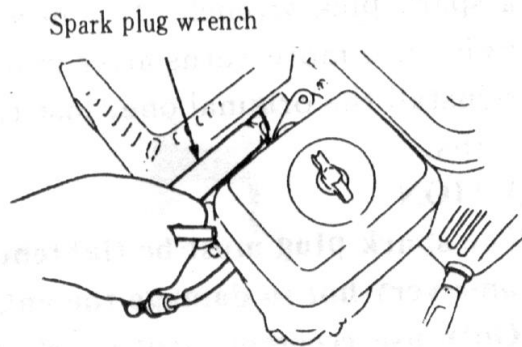

⚠ WARNING

Be careful not to touch the muffler during or just after the engine has been running.

- b) Clean the spark plug with a steel brush. If the insulator is damaged, replace the spark plug.
- c) Measure the spark plug clearance with a feeler. The clearance should be 0.7-0.8mm. If adjustment is necessary, bend the side electrode carefully.
- d) Check if the spark plug gasket is in good condition, or replace with a new one. Screw on the spark plug to the bottom first by hand and then tighten it up by a spark plug wrench. If a new spark plug is used, twist 1/2 more turns after impacting the gasket; if reinstall the original one, just twist 1/8-1/4 more turns

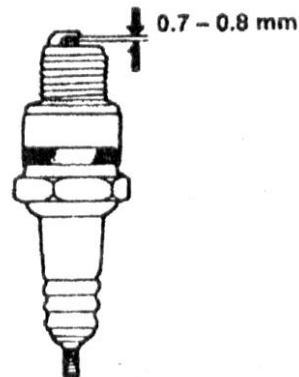

Engine Operation (cont'd)

Air Cleaner

Never run the generator without the air filter. Rapid engine wear will result.

1. Unsnap the air cleaner cover clips, remove the air cleaner cover, and remove the element.
2. Wash the air cleaner element in a solution of household detergent and warm water, then rinse thoroughly, or wash in nonflammable or high flashpoint solvent. Allow the air cleaner element to dry thoroughly.
3. Soak the air cleaner element in clean engine oil and squeeze out the excess oil. The engine will smoke during initial startup if too much oil is left in the air cleaner element.
4. Reinstall the air cleaner element and the cover.

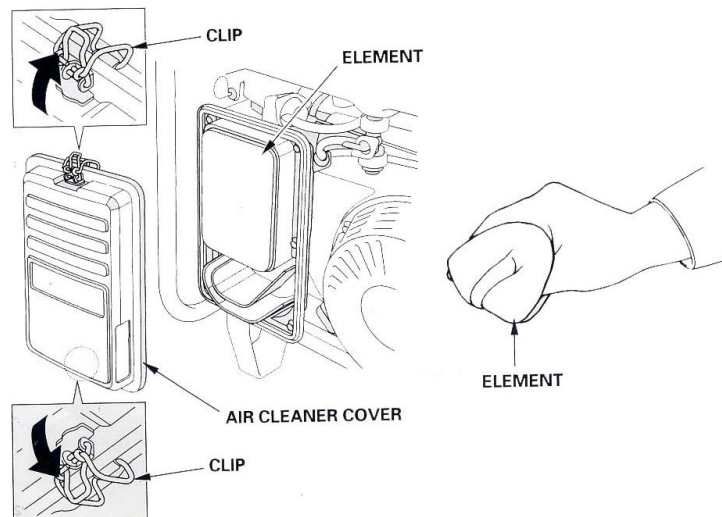

Cleaning Sediment Cup

The sediment cup prevents dirt or water which may be in the fuel tank from entering the carburetor. If the engine has not been run for a long time, the sediment cup should be cleaned.

1. Turn the fuel valve lever to the OFF position. Remove the sediment cup, O-ring and filter.
2. Clean the sediment cup, O-ring, and filter in nonflammable or high flash point solvent.
3. Reinstall the filter, O-ring, and sediment cup.
4. Turn the fuel valve lever ON and check for leaks.

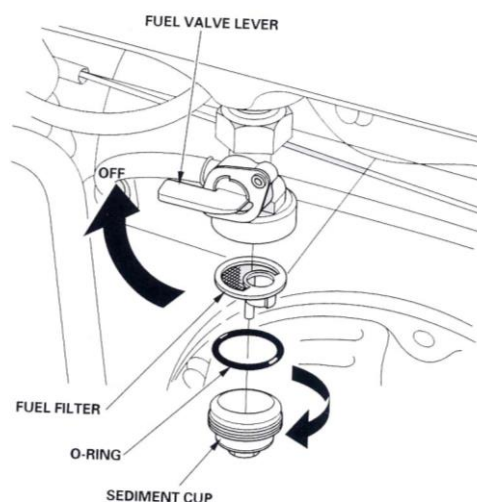

Engine Operation (cont'd)

Storage

1. Replace engine oil.
2. Disconnect the spark plug. Fill a spoon of fresh engine oil from the spark plug mount hole into the cylinder. Rotate the engine to distribute engine oil evenly, followed by fitting the spark plug to original position.
3. Pull the starting rope slowly until feel a slight anti-action, and then keep pulling so as to align the arrow of the starting sleeve with the hole of the starter. At this time, both the inlet and outlet valves are closed so to help prevent the engine inside from rusting.

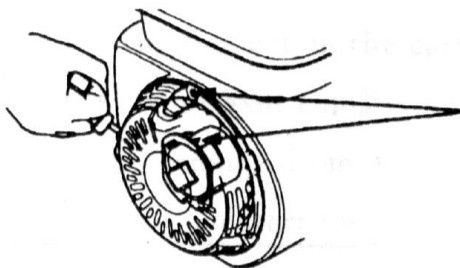

Align the arrow of the starting sleeve with the hole in the starter

4. Cover the engine so keep dust away.

Removal From Storage

Note: For the sake of environmental protection, we recommend discarding the old fuel by filling a closed container and taking it to a local recycling station for disposal.

Storage time	Service item
Within one month	Use
One-two months	Drain out original fuel of the fuel tank and refuel
Two months-one year	Drain out original fuel of the fuel tank and refuel; Drain out fuel in the carburetor Empty the deposit cup.
Above one year	Drain out original fuel of the fuel tank and refuel; Empty the fuel cup in the carburetor Empty the deposit cup; Move the engine from the storage place, fill it with fuel, then start up it.
Screw off the drain plug and drain out fuel in the carburetor. Turn off the engine switch first, disconnect the deposit cup and empty it.	

Engine Troubleshooting

ENGINE WILL NOT START	Possible Cause	Correction
1. Electric starting (applicable types): Check battery and fuse.	Battery discharged.	Recharge battery.
	Fuse burnt out.	Replace fuse
2. Check control positions.	Fuel valve OFF.	Move lever to ON position.
	Choke open.	Move lever to CLOSED position unless the engine is warm.
	Engine switch OFF.	Turn engine switch to ON position.
3. Check engine oil level.	Engine oil level low (Oil Alert models).	Fill with the recommended oil to the proper level
4. Check fuel.	Out of fuel.	Refuel
	Bad fuel; engine stored without treating or draining gasoline, or refueled with bad gasoline.	Drain fuel tank and carburetor. Refuel with fresh gasoline
5. Remove and inspect spark plug.	Spark plug faulty, fouled, or improperly gapped.	Gap or replace spark plug
	Spark plug wet with fuel (flooded engine).	Dry and reinstall spark plug.
6. Take engine to an authorized servicing dealer, or refer to shop manual.	Fuel filter restricted, carburetor malfunction, ignition malfunction, valves stuck, etc.	Replace or repair fault components as necessary.
ENGINE LACKS POWER	Possible Cause	Correction
1. Check air filter.	Filter element(s) restricted.	Clean or replace filter element(s).
2. Check fuel.	Bad fuel; engine stored without treating or draining gasoline, or refueled with bad gasoline.	Drain fuel tank and carburetor. Refuel with fresh gasoline.
3. Take engine to an authorized servicing dealer, or refer to shop manual.	Fuel filter restricted, carburetor malfunction, ignition malfunction, valves stuck, etc.	Replace or repair fail components as necessary.



WARNING:

When testing the spark plug, never hold the high-voltage wire of the spark plug with wet hand. Make sure there is no spilled fuel outside the engine and that the spark plug isn't dipped with fuel. To prevent fire, keep sparks far away from the spark plug mount hole.

Engine Specifications

Model Items			
Ignition system	Non – transistorized ignition (TCI)		
Spark plug type	NHSP LD F7TC		
Out direction of power shaft	Counterclockwise		

Spark plug clearance (gap)	0.7-0.8 mm
Valve clearance (cold engine)	Intake: 0.10±0.02mm; Exhaust: 0.15±0.02mm
Oil Capacity	0.53 US qt (0.5 liters)
Fuel	Unleaded gasoline octane rating 86 or higher

TIMING OF DISTRIBUTION

Intake valve opening: BTDC10°;
 Intake valve closing: ABDC20°;
 Exhaust valve opening: BBDC30°;
 Exhaust valve closing: ATDC10°

TIGHTENING TORQUE OF IMPORTANT BOLTS

S/N	Item	Torque Value (N · m)
1	Cylinder head bolt	24
2	Flywheel bolt	70-80
3	Crankcase cover bolt	24
4	Tie – rod bolt	12

Electrical Diagram

ELECTRIC DIAGRAM

Bl	Black
Y	Yellow
G	Green

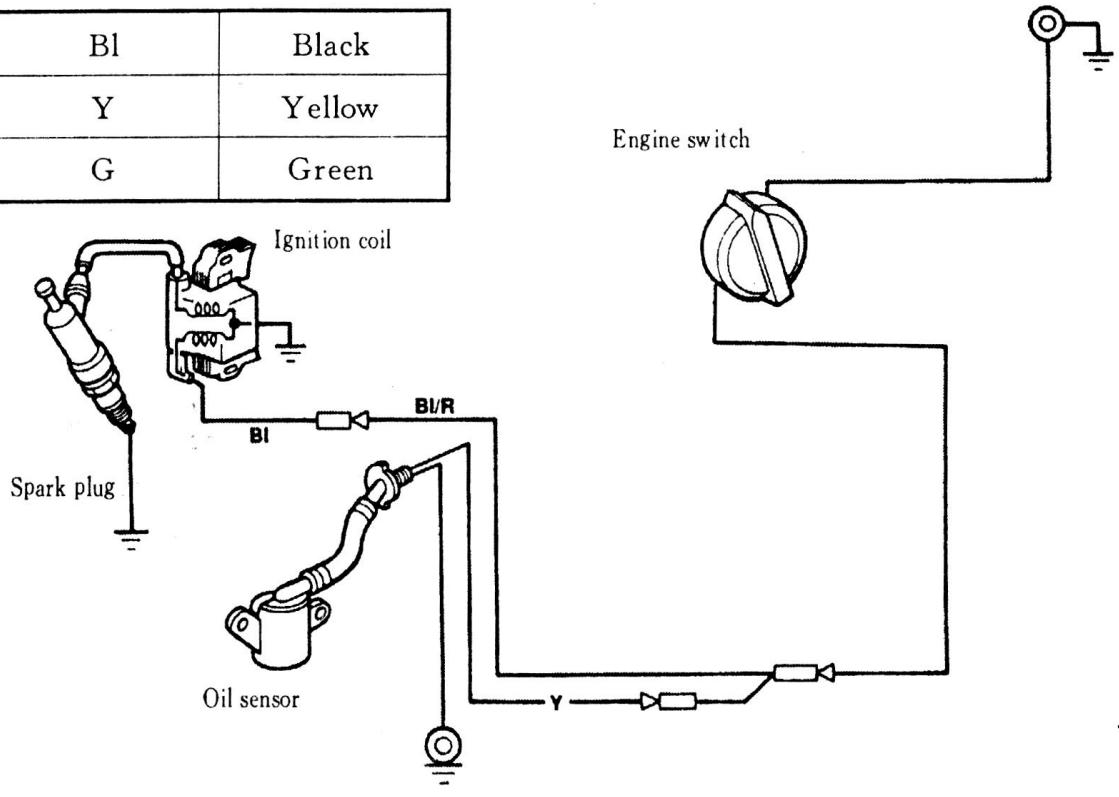

166111 Engine Parts Rev – G



166111 Generator Parts Rev – G

Ref#	Part #	Description	Qty	Ref#	Part #	Description	Qty
1	N/A	Crankshaft	1	38	N/A	Crankshaft Assembly	1
2	Kit #4	Ball bearing	2	39	N/A	Lifter, Valve	2
3		Oil Seal	2	40	Kit #4	Packing, Case cover	1
4	N/A	Governor Assembly	1	41	N/A	Camshaft Assembly	1
5	N/A	Shaft, Governor Arm	1	42	N/A	Pin, Dowel	2
6	N/A	Washer, Governor Arm Shaft	1	43	Kit #4	Bolt	6
7	N/A	Pin, Lock	1	44	N/A	Gasket, Cylinder Head	1
8	Kit #7	Bolt, Drain Plug	2	45	N/A	Bolt	4
9		Washer, Drain Plug	2	46	783127	Spark Plug	1
10	788901	Switch Assembly, Oil Level	1	47	N/A	Rod, Push	2
11	N/A	Bolt	2	48	N/A	Shroud	1
12	Kit #4	Dowel pin, Case cover	1	49	Kit #1,#5,#8	Bolt	13
13		Dowel pin, Case cover	1	50	Kit #5	Packing, Head cover	1
14	N/A	Piston	1	51		Cover, Cylinder Head	1
15	N/A	Scraper Ring Set ,Piston	1	52	N/A	Wind Shield Comp.	1
16	N/A	Rod Assembly, Connecting	1	53	N/A	Bolt	1
17	N/A	Pin, Piston	1	54	Kit #1	Fan, recoil starter	1
18	N/A	Clip, Piston	2	55		Pulley, Starter	1
19	Kit #4	Cover Assembly, Crankcase	1	56		Nut	1
20	N/A	Cylinder head	1	57	Kit #6	Ignition coil assembly	1
21	N/A	Valve, In	1	58		Bolt	2
22	N/A	Valve Exhaust	1	59	Kit #2	Packing, Intake	1
23	N/A	Returner, Intake Valve	1	60		Insulator, carburetor	1
24	N/A	Spring, Valve	2	61		Packing, carburetor	1
25	N/A	Seat, Valve spring, In	1	62		Spacer, carburetor	1
26	N/A	Seat, Valve spring, Ex	1	63	Kit #10	Rod, Governor	1
27	N/A	Plate, Push Rod Guide	1	64		Spring, Throttle Return	1
28	N/A	Rocker Assembly	2	65	Kit #1	Recoil Starter Assembly	1
29	N/A	Rotator	1	66	N/A	Shroud Assembly, upper	1
30	Kit #2	Bolt, Stud	2	67	Kit #3	Air Cleaner Assembly	1
31	N/A	Bolt, Stud	2	68		Tube, Breather	1
32	Kit #2	Carburetor	1	69	Kit #9	Rubber ,fuel	1
33	Kit #9	Fuel line	1	70	Kit #10	Spring, Governor	1
34		Clip, fuel line	1	71	Kit #8	Amplifier/Oil Alert	1
35	N/A	Governor arm	1	72	783136	Dipstick	1
36	N/A	Bolt, Governor Arm	1	73	N/A	Clip	1
37	Kit #3	Nut	3	74	N/A	Flywheel Assembly	1

166111 Engine Kits Rev – G

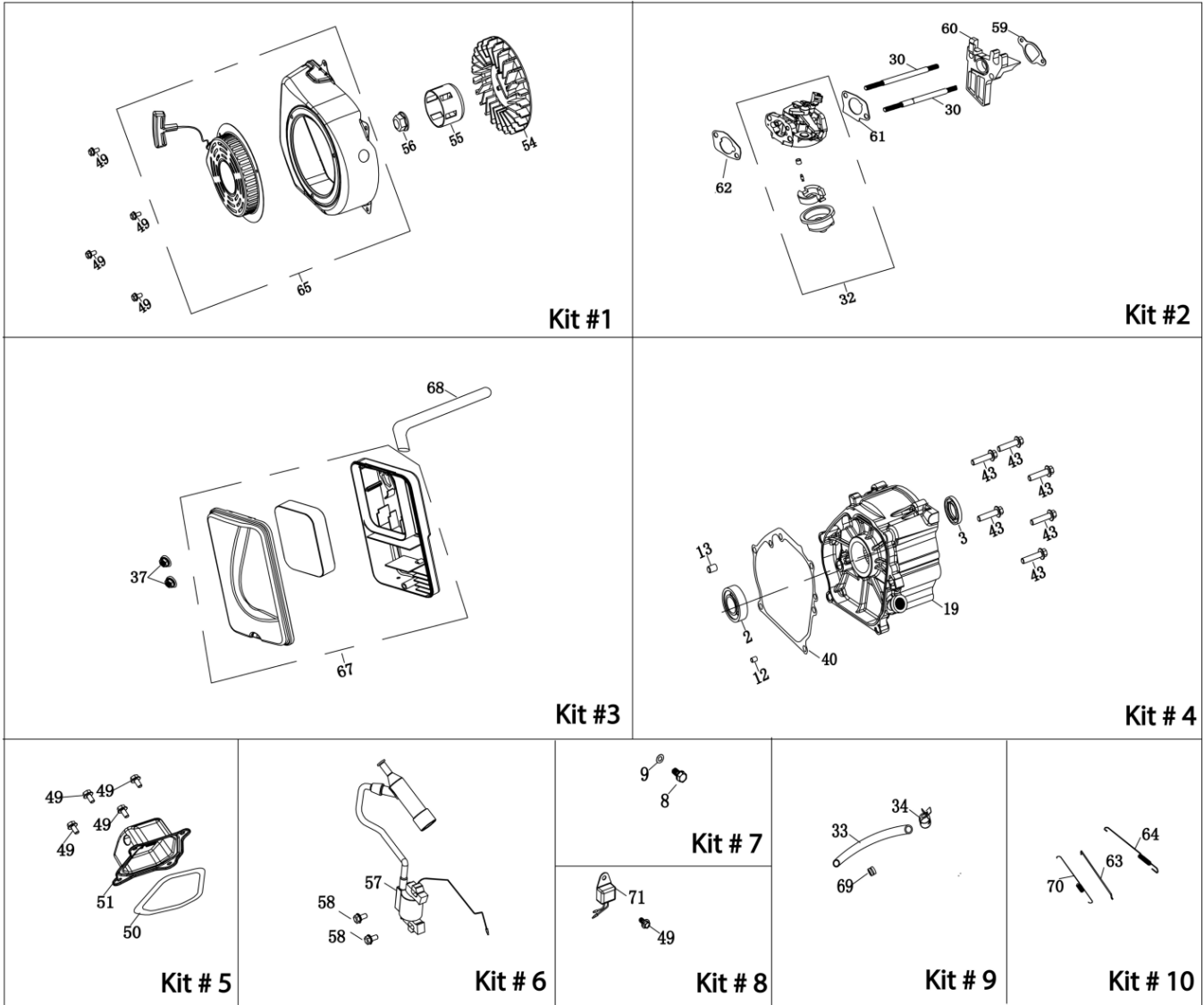

Kit Ref #	Kit Part #	Description	Qty
1	789258	Recoil & Fan Kit	1
2	789254	Carburetor Kit	1
3	789255	Air Filter Kit	1
4	790260	Rear Case Cover Kit	1
5	789253	Valve Cover Kit	1
6	789257	Ignition Coil Kit	1
7	783126	Drain Bolt Kit	2
8	787154	Oil Alert Kit	1
9	789260	Fuel Line Kit	1
10	790221	Governor & Spring Kit	1

166111 Generator Parts Rev – G

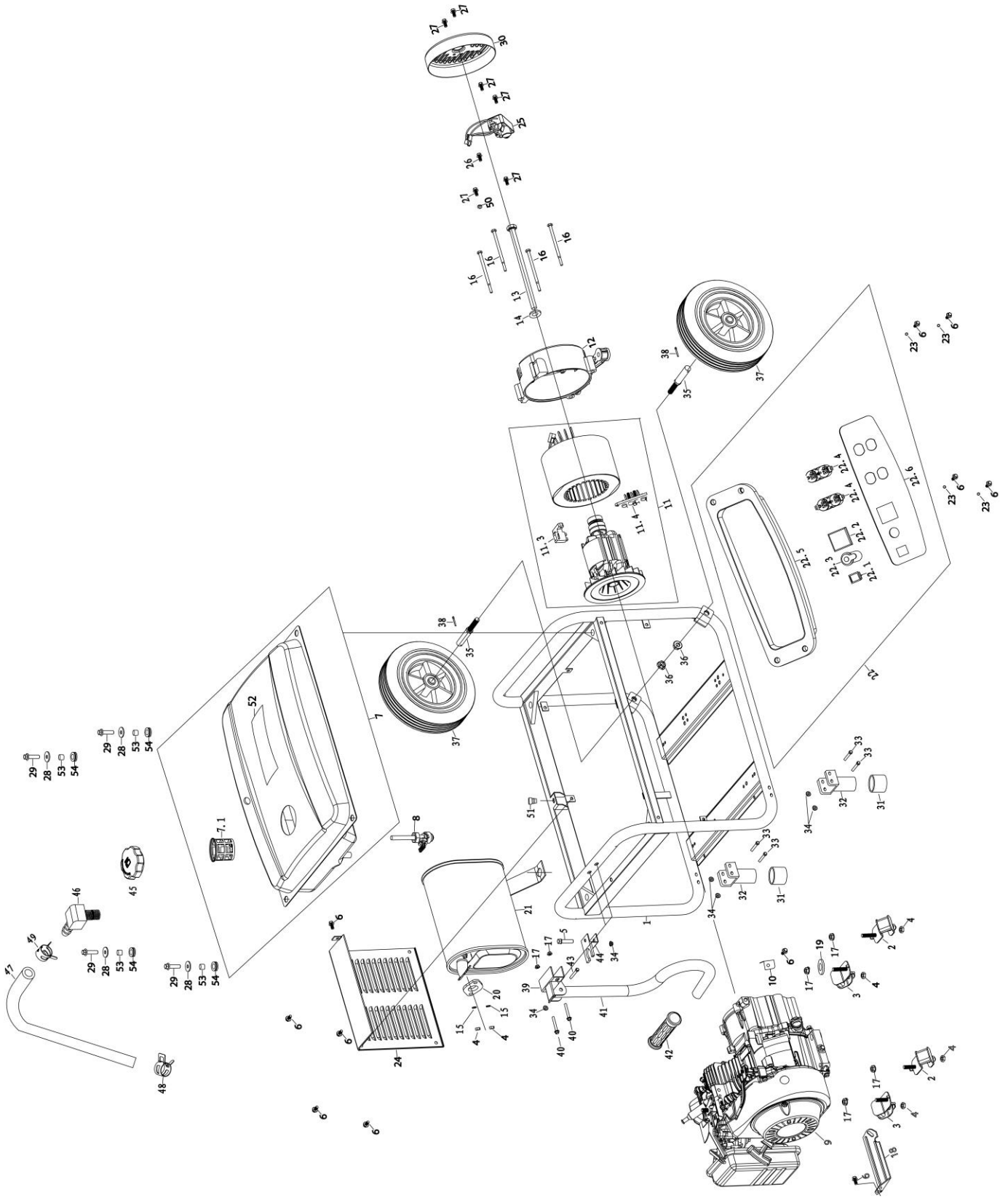

166111 Generator Parts Rev – G

Ref#	Part #	Description	Qty
1	789268	2200 Frame	1
2	Kit #5	Isolator A	2
3	Kit #6	Isolator B	2
4	Kit #5, #6	Nut	6
5	Kit #2	Bolt	1
6	Kit #7, #13	Bolt	11
7	Kit #10	Fuel Tank Assembly	1
7.1	Kit #8, #10	Fuel Filter	1
8	Kit #10 or 789404	Fuel Valve	1
9	794442	208cc Engine Assembly w/Air Filter and Muffler	1
10	N/A	Dustproof Sheet	1
11	789275	Generator Assembly	1
11.3	Kit #14	Carbon Brush	1
11.4		Terminal Block	1
12	783131	Generator Bracket	1
13	Kit # 15	Bolt	1
14		Flat Washer	1
15	N/A	Spring Washer	2
16	Kit # 15	Bolt	4
17	Kit #1, #5, #6	Nut	6
18	N/A	Bracket, Air Cleaner	1
19	N/A	Washer, Crankshaft	1
20	Kit #7	Packing, Exhaust	1
21		Muffler	1
22	Kit #13	Control Panel	1
22.1	Kit #13 or 783063	Switch Assembly	1
22.2	Kit #13 or 783100	150V Voltage Meter	1
22.3	Kit #13 or 783059	12V DC Receptacle	1
22.4	Kit #13 or 783053	5-20R Duplex Receptacle	2
22.5	Kit #13 or 789277	Rear Panel Cover	1
22.6	Kit #13 or 789278	Front Panel Board	1
23	Kit #13	Washer	4

Ref#	Part #	Description	Qty
24	Kit #7	Shield, Out Muffler	1
25	Kit #11	Automatic Voltage Regulator	1
26	Kit #14	Bolt	1
27	Kit #11, #12, #14	Bolt	7
28	Kit #9, #10	Washer, Fuel Tank	4
29		Bolt	4
30	Kit #12	End Cover, Generator	1
31	Kit #4	Support, Frame	2
32		Vibration Isolation Pad, Square	2
33		Bolt	4
34	Kit #1, #2, #4	Nut	6
35	Kit #3	Axle	2
36		Nut	2
37		Wheel	2
38		Cotter Pin	2
39	Kit #1	Connector, Handle	1
40		Bolt	2
41		Handle Assembly	1
42		Rubber, Handle	1
43		Bolt, Handle	1
44	Kit #2	Handle Clip	1
45	Kit #8, #10	Fuel Tank Cap	1
46	Kit #10	Tank Vent Fitting	1
47		Connecting Pipe	1
48		Clip, Fuel Line	1
49		Clip, Fuel Line	1
50	Kit #14	Spring Washer	1
51	Kit #14	Vibration Isolation Pad	1
52	Kit # 10 or 782554	CPSC Decal	1
53	Kit #9, #10	Bushing	4
54		Grommet	4

166111 Generator Kits Rev – G

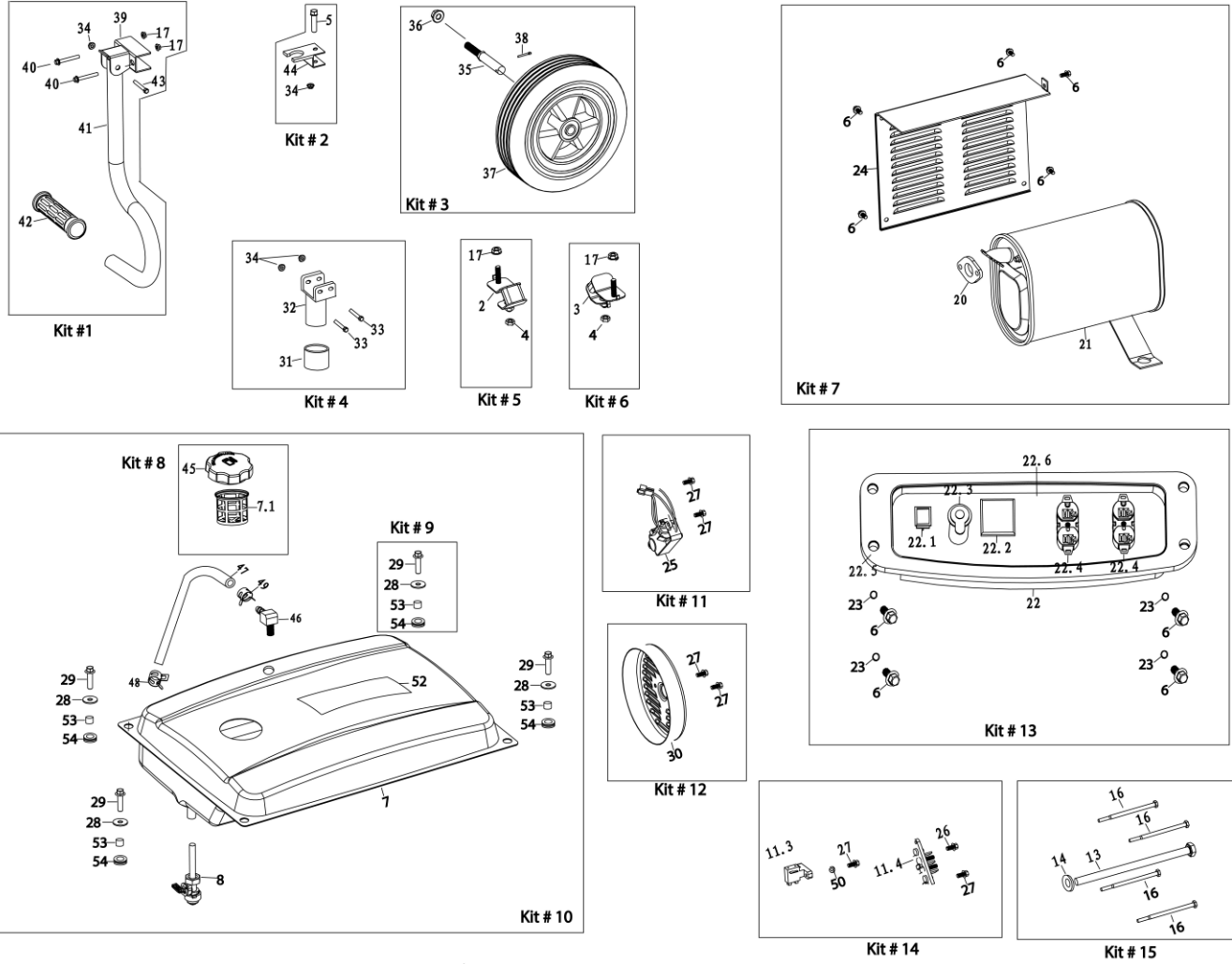

Kit Ref #	Kit Part #	Description	Qty
1	789264	Handle Kit	1
2	789265	Handle Restrictor Kit	1
3	789270	Wheel & Axle Kit	2
4	789266	Front Leg Support Kit	2
5	789267	Front Iso Mount & Bracket Kit	2
6	789269	Rear Iso Mount & Bracket Kit	2
7	789259	Muffler & Shield Kit	1
8	789262	Fuel Cap Kit	1
9	789261	Tank Bolt & Grommet Kit	4
10	789263	Tank Assembly	1
11	789273	Automatic Voltage Regulator Kit	1
12	789271	End Cover Kit	1
13	789276	Control Panel Assembly	1
14	789272	Brush & Terminal Block Kit	1
15	789274	Generator Stud Bolt Kit	1

Wheel Kit Assembly

Wheel Kit Parts Identification	Qty
M6 x 30 Bolt	7
M8 x 35 Bolt	1
M6 Nut	7
Handle Connector	1
M8 Nut	1
Handle	1
Rubber Grip	1
Frame Support	2
Rubber Cap	2
M12 Nut	2
Axle	2
Wheel	2
Pin	2

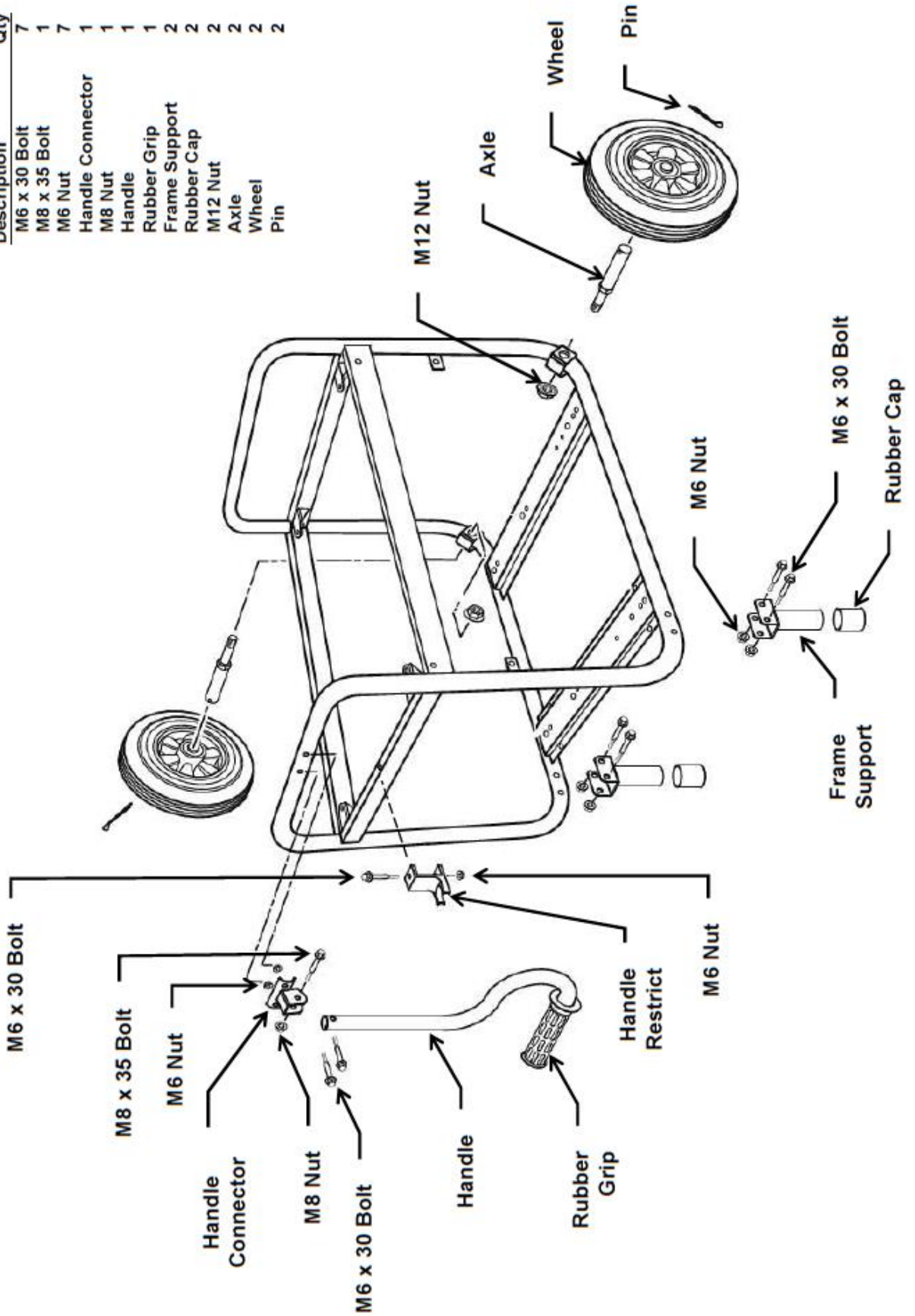

Limited Warranty

Dear Valued Customer:

The Powerhorse Product you just purchased is built with the finest material and craftsmanship. Use this product properly and enjoy the benefits from its high performance. By purchasing a Powerhorse product, you show a desire for quality and durability.

Like all mechanical equipment this unit requires a due amount of care. Treat this unit like the high quality piece of machinery it is. Neglect and improper handling may impair its performance. Please thoroughly read the instructions and understand the operation before using your product.

Limited Warranty

Powerhorse shall warranty any piece of equipment manufactured, or parts of equipment manufactured, to be free from defects in material or workmanship for a period of 2 years for noncommercial/nonrental use and a period of 90 days for commercial/rental use from the date of purchase by user. This warranty applies to the original purchaser of the equipment and is nontransferable. Verification of purchase is the responsibility of the buyer. Parts will be replaced or repaired at no charge, except when the equipment has failed due to lack of proper maintenance. Any misuse, abuse, alteration or improper installation or operations will void warranty. Determining whether a part is to be replaced or repaired is the sole decision of Powerhorse.

NOTE: Some services performed by parties other than Powerhorse may void warranty.

This warranty covers parts only. It will not provide for replacement of complete products due to defective parts. Components not manufactured by Powerhorse are guaranteed by their manufacturer and can be serviced at factory-authorized locations near you. Any costs incurred due to replacement or repair of items outside of a Powerhorse approved facility is the responsibility of the buyer and not covered under warranty. Powerhorse can supply you with the service center location in your area.

This warranty specifically excludes the following; failure of parts due to damage caused by accident, fire, flood, windstorm, acts of God, applications not approved by Powerhorse in writing, corrosion caused by chemicals, use of replacement parts which do not conform to manufacturer's specifications, and damage caused by vandalism. Additional exclusions: loss of running time, inconvenience, loss of income, or loss of use, including any implied warranty of merchantability of fitness for a specific use.

Warranty does not cover items subject to normal wear such as tires, receptacles or any part subject to direct physical contact by the public. This warranty does not cover any personal injury or damage to surrounding property caused by failure of any part.

This warranty is in lieu of any other warranty expressed or implied and Powerhorse assumes no other responsibility or liability outside that expressed within this warranty.

Please fill in the following information and have it on hand when you call in on a warranty claim.

Customer Number: _____

Date of Purchase: _____

Powerhorse Serial Number: _____

Item Number: _____



POWERHORSE®

Distributed by
Northern Tool + Equipment Co.,
2800 SouthCross Drive West
P.O. Box 1499 Burnsville, MN 55337-0499