



M165937I

ITEM NUMBER: 165937

SERIAL NUMBER: _____

Owner's Manual

Instructions for Installation/Set-up, Operation, Servicing, & Storage Portable Outdoor Use-Only, Power Take-Off (PTO) Generator

24,000 Watt Continuous (27,500 Watt Surge) Capacity

Can be used to power individual appliances plugged directly into the generator's outlets, or as a back-up connection to a building's power supply (via a professionally installed UL-approved transfer switch).

⚠ WARNING

READ and UNDERSTAND this manual completely before using the generator! Failure to properly set up, operate, and maintain this generator could result in *serious injury or death* from *carbon monoxide poisoning, electric shock, entanglement, fire, or burns*. In addition, *PTO shaft and generator can become airborne and cause severe injury* if improperly secured. In particular, be aware of the following hazards:

CO Poisoning

The running tractor engine gives off carbon monoxide, a poisonous gas that can kill you. You CANNOT smell it, see it, or taste it.

- ONLY run tractor and generator OUTDOORS and AWAY from building air intakes. NEVER run inside any enclosed or semi-enclosed spaces, including homes, basements, garages, sheds, and boxes. These spaces can trap poisonous gases, EVEN if you run a fan or open windows.
- Install carbon monoxide alarms inside nearby structures/buildings (battery-operated, or plug-in with battery backup).

Electric shock / Electrocution

- High voltage electricity from generator can kill. DO NOT operate in wet locations. Be sure generator is properly grounded. Use only UL-listed, outdoor-rated grounded GFCI-equipped extension cords of proper size.
- NEVER plug the generator directly into a wall outlet. ANY connection to a building's electrical system MUST ISOLATE THE GENERATOR FROM UTILITY POWER via a UL-approved transfer switch installed by a licensed electrician. Otherwise, back feed from the generator into the power grid could kill utility workers.

Fire

- DO NOT overload generator (per rated capacity), and OPERATE ONLY in an area with adequate cooling ventilation so generator does not overheat and possibly cause fire. Keep all objects at least 7' from generator vent openings. Refer to tractor manual for minimum safe clearance distance between hot tractor exhaust and nearby combustible materials and structures.
- ALWAYS keep a fire extinguisher rated "ABC" nearby.

Power Take-Off (PTO)

- Failure to properly mount and secure the generator may cause the unit to flip violently during use, which could cause severe injury to the operator or bystanders, or damage to surrounding objects.
- Never operate the generator without proper PTO guarding, including a freely rotating shaft guard as well as tractor and generator shields at each end. Clothing or hair can become rapidly entangled in unguarded rotating PTO shaft or connections, resulting in *serious injury or death*.
- Make sure PTO driveline shaft is securely locked at both ends. An unlocked PTO shaft can whip or become dangerously airborne.

STOP!

CHOOSE THE RIGHT GENERATOR FOR YOUR NEEDS. See the "Power load Planning & Management" section of this manual to determine your power load requirements and then compare to the generator's rated capacity.

INSPECT COMPONENTS: Closely inspect to make sure no components are missing or damaged. See the "Unpacking & Delivery Inspection" section for instructions on whom to contact to report missing or damaged parts.

MOUNTING IS REQUIRED. You will need to mount this PTO generator to either a (reinforced?) concrete slab or a PTO trailer. See the "About Your Generator" and "Installation/Initial Set-Up" sections for more information on this requirement.

ARRANGE FOR PROFESSIONAL INSTALLATION of a transfer switch if you will be connecting the generator to your building's electrical system. See the "Installation/Initial Set-Up" section for more information about this requirement.

Any Questions, Comments, Problems, or Parts Orders
Call NorthStar Product Support 1-800-270-0810

Hazard Signal Word Definitions





	<p>This is the safety alert symbol. It is used to alert you to potential personal injury hazards. Obey all safety messages that follow this symbol to avoid possible injury or death.</p>
	<p>DANGER (red) indicates an imminently hazardous situation which, if not avoided, will result in death or serious injury.</p>
	<p>WARNING (orange) indicates a potentially hazardous situation which, if not avoided, could result in death or serious injury.</p>
	<p>CAUTION (yellow) indicates a potentially hazardous situation which, if not avoided, may result in minor or moderate injury.</p>
	<p>CAUTION (yellow) used without the safety alert symbol indicates a potentially hazardous situation which, if not avoided, may result in property damage.</p>

fig01453

Table of Contents

Hazard Signal Word Definitions	2
About Your Generator	4
Specifications	6
Safety Label Locations	7
Machine Component Identification	8
Power Load Planning & Management	10
Installation / Initial Set-Up:	
1. Unpacking & Delivery Inspection	12
2. Planning the Power Load	13
3. Set-up as a PORTABLE or BUILDING BACK-UP Power Source	13
4. Selecting a Suitable Site	16
5. Mounting the Generator	18
6. Grounding the Generator	20
Operation:	
1. General Safety Rules for Operation	21
2. Preparing for Operation	23
3. Connecting to the Tractor	24
4. Starting the Generator	26
5. Connecting Loads	26
6. Stopping	28
7. Storage & Exercise	28
Maintenance & Repair	29
Troubleshooting	31
Summary of Important Safety Information for Operation	32
Generator Exploded View	35
Wiring Diagram	37
Gearbox Exploded View	39
Limited Warranty	41
California Proposition 65 Information	42

About Your Generator

Thank you for purchasing your NorthStar PTO generator!

About Your Generator

This PTO-driven, portable generator is designed to provide up to 24,000 Watts of electrical power (24,000 watts continuous, 27,500 watts surge). Connected to your tractor's power take-off (PTO)*, the generator can supply power:

1. As a portable power source. You can plug appliances directly into the generator's electrical outlets.
2. As a back-up, standby power source for a building. A licensed electrician can connect the generator to your building's electrical system via the installation of an **UL-approved transfer switch**. (See the "Installation & Initial Set-up" section of this manual to learn more about specific requirements and precautions relating to wiring the generator to your building's electrical system.)

* Your tractor's PTO must produce a minimum of 48 HP at 540 RPM.

You must select a generator adequately sized for your power needs. You need to determine the power needs of all the appliances/tools you wish to power at the same time and choose a generator rated to provide at least that power level. See the "Power Load Planning & Management" section of this manual to determine your specific power load requirements and then compare them to this generator's rated capacity. You must not overload the generator. Overloading will cause damage to the generator and attached electrical devices, and may also result in fire.

This generator must be mounted on a reinforced concrete slab or a PTO generator trailer, so that the generator will not flip during use due to the rotational force of the PTO. The slab or trailer must be of adequate size and strength to withstand operating torque without flipping or structural failure. A trailer designed specifically for use with PTO generators rated up to 60,000 Watts is available from NorthStar -- Item #165959. More detailed information about mounting can be found in the "Installation / Initial Set-Up" section of this manual.

Be sure to read about site selection and grounding requirements for running this generator. More detailed information can be found in the "Installation & Initial Set-up, Steps 5 & 6" of this manual.

Optional accessories available from NorthStar include PTO drivelines, UL-approved transfer switches and extension cords. **Contact NorthStar Product Support at 1-800-270-0810 with questions about optional accessories or to order.**

Read this Manual

WARNING

Improper use or maintenance of this generator can result in *serious injury or death* from *carbon monoxide poisoning, electric shock/electrocution, entanglement, flying objects, fire, or burns*. In addition, *PTO shaft and generator can become airborne and cause severe injury* if improperly secured.

Read this manual completely before using the generator and follow all instructions and safety rules.

About Your Generator (cont'd)

You must follow all instructions and safety precautions presented throughout this manual. A summary of important safety information can be found at the end of the manual. Keep this manual for reference and review.

Proper preparation, operation, and maintenance will result in operator safety as well as best performance and long life of the generator. Failure to follow the instructions in this manual for proper mounting, set-up, operation, and maintenance of the generator will void the manufacturer's warranty.

Before using, the user shall determine the suitability of this product for its intended use and assumes liability therein. The purchaser and/or user shall assume liability for any modification and/or alterations of this equipment from original design and manufacture, or for any non-standard application, or for use as a subcomponent in another piece of equipment.

NorthStar is constantly improving its products. The specifications outlined herein are subject to change without prior notice or obligation.

Contact NorthStar Product Support at 1-800-270-0810 for any questions about the appropriate use of this generator.

Warranty Registration

Please fill out and submit the warranty registration card so that we have your contact information for any future product literature or replacement parts you may need.



ATTENTION:
All Rental Companies and Private Owners who loan this equipment to others!

All persons to whom you rent/loan this generator must have access to and read this manual. Keep this owner's manual with the generator at all times and advise all persons who will operate the machine to read it. You must also provide personal instruction on how to safely operate the generator and remain available to answer any questions a renter/borrower might have.

Specifications – Item # 165937

<i>SPECIFICATIONS</i>	
Item Number	165937
Maximum Output	27500 Watts (W)
Continuous Output	24000 W
Voltage	120 / 240 Volt (V)
Phase	Single phase (4-wire)
Frequency	59.0-63.0 Hertz (Hz)
Power Factor	1.0
Minimum PTO HP	48 HP at 540 RPM
Minimum Operation Torque	358.7 pound-foot
Input Shaft	1-3/8" Diameter, 6 spline
120V Receptacle	(2) 20 Amp (A) duplex (NEMA 5-20R) 30A Locking device (NEMA L5-30R)
120/240V Receptacle	60A Straight blade (NEMA 14-60R) 175A Anderson Style.
Circuit Breaker	(2) 20A thermal, push to reset style 30A thermal, push to reset style 60A thermal magnetic 100A thermal magnetic
Gear Box	
Gear Ratio	1:7
Gear Oil	SAE 90W
Oil Capacity	1.11 Qt. (1.05 L)
Dimensions	
Length	36.95" (93.9 cm)
Width	16.85" (42.8 cm)
Height	20.79" (52.8 cm)
Gross Weight	425 lb. (193.2 kg)

Machine Component Identification - Item #165937

⚠ DANGER	⚠ WARNING	
 <p>Poisonous Gas Hazard Tractor engines give off carbon monoxide, an odorless gas that can kill you in minutes.</p> <ul style="list-style-type: none"> ◆ ONLY run tractor & generator OUTDOORS and AWAY from building air intakes. ◆ Never run inside homes, garages, or sheds, EVEN if you run a fan or open windows. ◆ Install carbon monoxide alarms inside nearby structures/buildings. 	 <p>Electric Shock/Electrocution Hazard High voltage from generator can kill.</p> <ul style="list-style-type: none"> ◆ NEVER connect generator directly into a wall outlet. ◆ ANY connection to a building's electrical system MUST ISOLATE GENERATOR FROM UTILITY POWER via a transfer switch. ◆ Be sure generator is properly grounded. ◆ Use only outdoor-rated, grounded GFCI extension cords of proper size. ◆ DO NOT operate in wet locations. 	 <p>A Fire Hazard can arise from:</p> <ul style="list-style-type: none"> ◆ Overloading the generator ◆ Lack of cooling ventilation ◆ Contact with hot tractor exhaust <ul style="list-style-type: none"> ◆ DO NOT overload generator. ◆ OPERATE ONLY with adequate cooling ventilation. Keep all objects at least 7 feet from generator vent openings. ◆ Keep tractor exhaust away from all combustible objects. ◆ ALWAYS keep a fire extinguisher nearby.
<p>Read Owner's Manual completely before using. Serious injury or death can result if safety directions are not followed.</p>		

⚠ DANGER

Using a generator indoors CAN KILL YOU IN MINUTES. Generator exhaust contains carbon monoxide. This is a poison you cannot see or smell.



NEVER use inside a home or garage. EVEN IF doors and windows are open.



Only use OUTSIDE and far away from windows, doors, and vents.

	⚠ DANGER!
	<p>Rotating Driveline/PTO Hazard Contact with rotating driveline can cause death!</p> <ul style="list-style-type: none"> • Driveline guard, plus tractor and generator shields must be in place. Driveline guard must turn freely and independently on driveline. <i>Accidental contact with rotating driveline will cause hair or clothing near rotating shaft to become rapidly entangled.</i> • Driveline must be securely locked at both ends. <i>An unlocked PTO shaft can whip or become dangerously airborne.</i> • Generator must be properly mounted in accordance with instructions. <i>Improper mounting may cause generator to flip dangerously during use.</i>

Always make sure safety labels are in place and in good condition. If a safety label is missing or not legible, order new labels or unsafe operation could result.

To order replacement safety labels, call NorthStar Product Support at 1-800-270-0810.

On-Product Warning Labels	
Part numbers	Description
779781	General Warning
779770	PTO Warning
779407	Danger Carbon Monoxide

About Your Generator (cont'd)

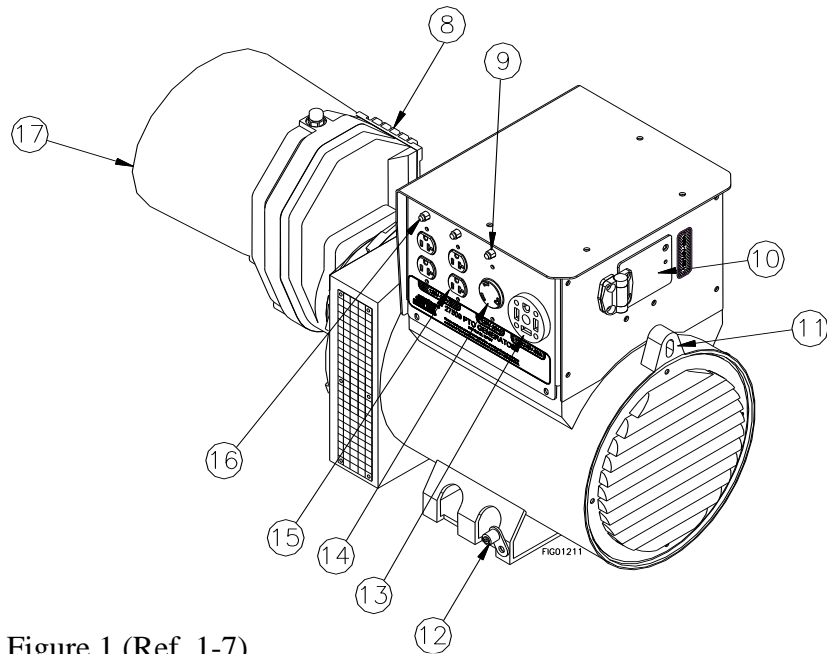

Figure 1 (Ref. 1-7)

Ref.	Description	Ref.	Description
1	Voltmeter	10	120/240V 100A Connector
2	Lifting Eye	11	Lifting Eye
3	Breather/Oil Fill Plug	12	Grounding Clamp
4	1 3/8", 6 Spline Input Shaft	13	120/240V 60A Receptacle
5	Sight Glass	14	120V 30A Locking Receptacle
6	100A Circuit Breaker	15	120V 20A Duplex Receptacles
7	60A Circuit Breaker	16	20A Circuit Breakers
8	Gear Box	17	Shield
9	30A Circuit Breaker		

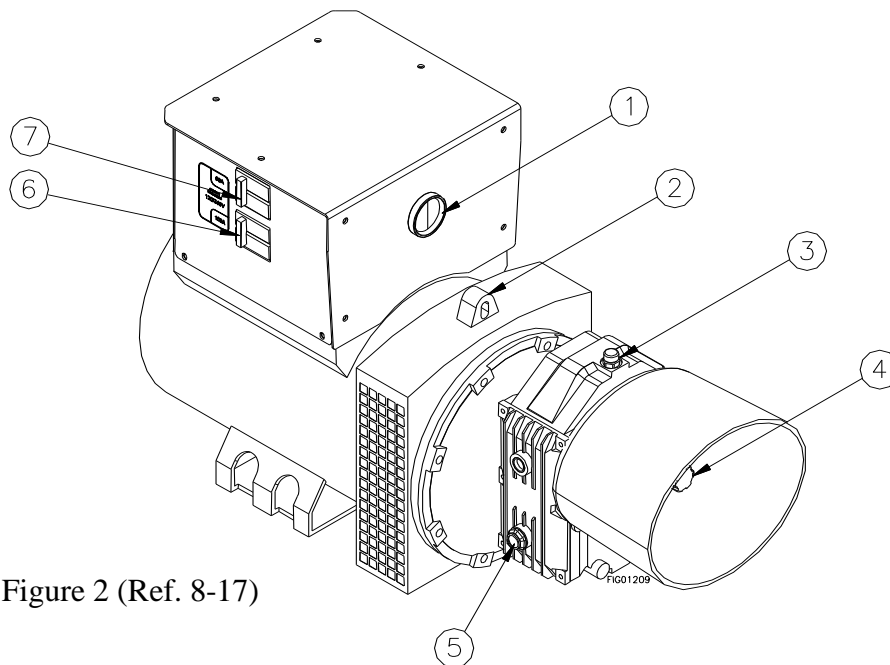

Figure 2 (Ref. 8-17)

Machine Component Identification – Item #165937 (cont'd)

REFERENCE GUIDE	
Reference 1 – Voltmeter	Voltmeter needle should be in green area during all generator load conditions. The black line in the center on the green area indicates 120V. During no load conditions, the needle should be at or above the black line.
Reference 2 – Lifting Eye	Use when lifting or moving generator.
Reference 3 – Breather/Oil Fill Plug	Use SAE 90W gear oil. Maintain the correct oil level. Over filling can cause the oil to over heat and damage seals and bearings.
Reference 4 – 1-3/8” Diameter 6 Spline Input Shaft	A 540 RPM., PTO drive line is available from Northern, Item #165936.
Reference 5 – Sight Glass	Fill gearbox until oil is in the middle of the sight glass.
Reference 6 – 100A Circuit Breaker	One 100A thermal-magnetic circuit breaker.
Reference 7 – 60A Circuit Breaker	One 60A thermal-magnetic circuit breaker.
Reference 8 – Gearbox	Cast iron frame. 1:7 gear ratio.
Reference 9 – Circuit Breaker	One 30A push-to-reset thermal circuit breaker.
Reference 10 – 120/240V 100A Connector	This extremely safe and durable receptacle can be used for all large loads, including transfer switches. A plug (part #37552) can be ordered from NorthStar at 1-800-270-0810.
Reference 11 – Lifting Eye	Use when lifting or moving generator.
Reference 12 – Grounding Clamp	Ground the generator via the grounding clamp, to a copper pipe or rod that is driven into moist soil.
Reference 13 – 120/240V Receptacle	This straight blade receptacle is rated for 120/240V-60A. This receptacle accepts a NEMA plug number 14-60P.
Reference 14 – 120V Receptacle	This locking device receptacle is a 120V-30A receptacle, National Electrical Manufacturer's Association (NEMA) number L5-30R. This receptacle accepts NEMA plug number L5-30P.
Reference 15 – 120V Receptacle	The generator has a control panel with two 120V-20A straight blade duplex receptacles (two receptacles in a common housing). NEMA number is 5-20R.
Reference 16 – Circuit Breaker	Two 20A push-to-reset thermal circuit breakers.
Reference 17 - Shield	Plastic implement shield. NEVER operate generator without shield in place.

Power Load Planning & Management

⚠ WARNING

NEVER exceed the rated wattage capacity of your generator.
 OVERLOADING may cause SERIOUS DAMAGE to the generator and attached electrical devices, and may result in fire.

Your generator **MUST BE SIZED PROPERLY** to provide both the running and starting (surge) wattage of the devices you will be powering. Before using your generator, determine the running and starting wattage requirements of all the electrical devices you will be powering simultaneously. The sum of the running and starting wattages of the devices being powered must not exceed the continuous output rating of your generator. (The continuous output rating of your generator is listed in the “Specifications” section of this manual.) Note that:

- Devices without electric motors such as light bulbs, radios, and televisions have the same running and starting wattage.
- Devices with electric motors such as refrigerators, compressors, and hand tools typically require a starting wattage that is 3 to 5 times greater than the running wattage.

The running and starting wattage requirements are often listed on a device’s nameplate. If wattage is not given on the device’s nameplate, the wattage may be calculated by multiplying the nameplate voltage by nameplate amperage, $\text{Watts} = \text{Volts} \times \text{Amps}$.

Example conversion to watts:

$$120 \text{ Volts} \times 5 \text{ Amps} = 600 \text{ Watts}$$

If only the running voltage is given on the nameplate for a device with an electric motor, the starting wattage can be approximated to be three to five times the running wattage.

Estimates for the running wattage requirements for common devices are listed in **Table 4** below. Guidance for starting wattages is provided in the table’s footnotes.

Table 4

Device	Running Watts	Device	Running Watts
Air conditioner (12,000 BTU)	1700 (a,b)	Jet pump	800 (a)
Battery charger (20 Amp)	500	Lawn mower	1200
Belt sander (3")	1000	Light bulb (100 Watt)	100
Chain saw	1200	Microwave oven	700
Circular saw (6½")	2000 (a,b)	Milk cooler	1100 (a)
Coffee maker	1800 (a,b)	Oil burner on furnace	300
Compressor (1 HP)	1400 (a,b)	Oil-fired space heater (140,000 Btu)	400
Compressor (¾ HP)	1800 (a)	Oil-fired space heater (85,000 Btu)	225
Compressor (½ HP)	1400 (a)	Oil-fired space heater (30,000 Btu)	150
Curling iron	700	Oven	4500
Dishwasher	1200	Paint sprayer, Airless (1/3 HP)	600 (a)
Edge trimmer	500	Paint sprayer, Airless (handheld)	150
Electric nail gun	1200	Radio	200
Electric range (1 element)	1500	Refrigerator	600 (b)
Electric skillet	1250	Slow cooker	200

Power Load Planning & Management (cont'd)

Device	Running Watts	Device	Running Watts
Furnace fan (1/3 HP)	1200 (a)	Submersible pump (1-1/2 HP)	2800 (a)
Freezer	800 (b)	Submersible pump (1 HP)	2000 (a)
Hair dryer	1200	Submersible pump (1/2 HP)	1500 (a)
Hand drill (1")	1100	Sump pump	600 (a)
Hand drill (1/2")	875	Table saw	2000 (a)
Hand drill (3/8")	500	Television	500
Hand drill (1/4")	250	Toaster	1000
Hedge trimmer	450	Vacuum cleaner	250
Home computer	150	VCR	70
Impact wrench	500	Water Heater	3000
		Weed trimmer	500

(a) Hard-starting motors require 3-5 times the rated running watts

(b) For extremely hard to start loads such as air conditioners and air compressors, consult the equipment dealer to determine maximum wattage

To calculate the running and starting wattage requirements for the devices you will be powering, follow these steps:

1. Make a list of all electrical devices you will be powering at the same time with the generator.
2. List the greater of the running or starting wattage next to each device as obtained from the devices' nameplate or **Table 4**. If only the running wattage for a device with an electric motor is known, the starting wattage can be estimated to be at least 3 times the running wattage.
3. Add the wattages for all devices on your list. This total must be lower than the continuous output rating of your generator.

Example:

Device to be Powered	Greater of Starting/Running Wattage
Light Bulb	75 W
Refrigerator – 18 Cu. Ft.	1600 W
Microwave	700 W
Window AC	1800 W
Sump pump (1/3 hp)	2100 W
Total	6275W

In this example, the generator must have a continuous output of at least 6275 W in order to power all of the devices simultaneously.

STAGGERING LOADS

You can increase the number of devices your generator can power by staggering the load on the generator. For example, you could alternately power your refrigerator and air conditioner for limited periods of time -- powering only one of the devices at a time and never powering both at the same time.

Installation / Initial Set-Up

There are a number of important steps required to set up your generator for initial use. These steps are:

Steps for Installation / Initial Set-Up

1. **Unpacking & delivery inspection.**
2. **Planning the power load to stay within the generator's rated capacity.**
3. **Setting up generator for the type of power generation you need:**
 - a. **portable power source, or**
 - b. **connected to a building as a back-up power source.**
4. **Selecting a site for using the generator.**
5. **Mounting the generator.**
6. **Grounding the generator.**

Each of these steps is discussed in detail below:

1. Unpacking & Delivery Inspection

1. You should inspect the generator immediately after you receive delivery.

See the "Machine Component Identification" section of this manual for a diagram of the generator and its components.

- If you have missing or damaged components, contact Product Support at 1-800-270-0810.

2. The gearbox is shipped with oil and a temporary shipping plug.

- a. Remove the temporary shipping plug and replace with the metal breather/oil fill plug that is in the manual bag.
- b. Make sure that the gear oil level is in the middle of the sight glass, at the red dot. Add SAE 90W gear oil as required.

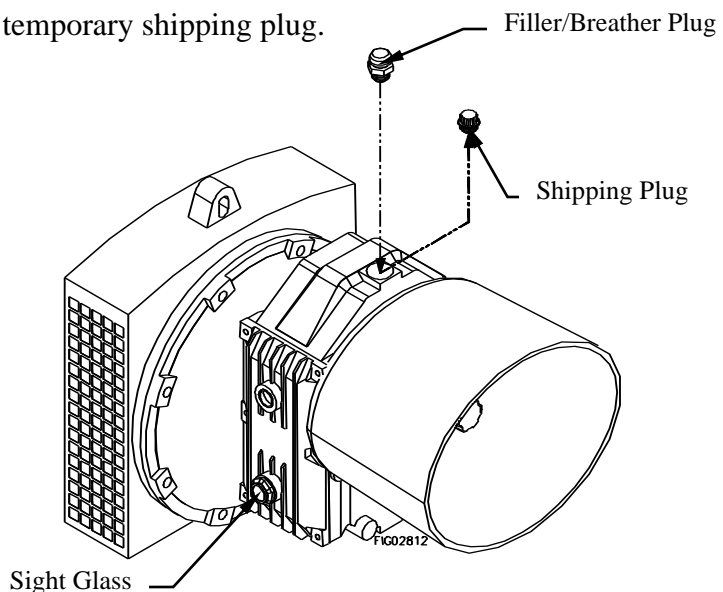

Installation / Initial Set-Up

2. Planning the Power Load

Plan your power load so that you do not exceed the generator's rated capacity.

See the "Power Load Planning & Management" section of this manual to review how to plan and manage power loads for the generator.

3. Set-up either as a BUILDING BACK-UP or PORTABLE Power Source

This generator is designed to provide up to 24,000W of continuous electrical power. It can supply electricity in two ways:

1. **As a back-up, standby power source for a building.** For this application, you must arrange for a licensed electrician to connect the generator to your building's electrical system via the installation of an UL-approved transfer switch. The transfer switch must be installed in accordance with building electrical code and guidelines supplied by your power company.
2. **As a portable power source.** You can plug appliances or tools directly into the generator's electrical outlets.

Specific requirements for each are given below.

Note: Regardless of whether you use your generator as a back-up power source connected to a building or as a portable power source, you must not overload the generator. Overloading may cause serious damage to the generator and attached electrical devices.

Using as a Back-up Power Source for a Building

Contact a licensed electrician to install a UL-approved transfer switch if you want to use your generator as a back-up power source for a building.

What does a transfer switch do? It:

- a) Safely connects the generator to your building's electrical system by isolating your generator from your utility company's power lines, AND
- b) Connects your generator to a critical subset of your building's circuits that are needed for emergency power needs.

If your generator will be connected to your building's electrical system, it **MUST ALWAYS** be isolated from the utility power grid with a *UL-approved transfer switch installed by a licensed electrician* in compliance with all applicable building and electrical codes, and in accordance with guidelines supplied by your power company.

DANGER:

A transfer switch must be installed in order to isolate your generator from the utility power grid. If your generator is **NOT** properly isolated from the utility system, serious hazards will arise:

- ◆ When your generator is running, its output will back feed into the utility power line and transformer that are normally used to provide you with power. The transformer will step up the current to the normal line voltage. An unsuspecting utility line worker working on what he thinks is a deactivated line could be electrocuted.

Installation / Initial Set-Up

- ◆ If your generator is connected (running or not) when utility power is restored, your generator will be destroyed. It could also explode or cause fire.

In addition to isolating your generator from the utility system, the transfer switch connects your generator to a limited set of circuits in your building that have been chosen as critical to operate during a power outage.

This generator can power up to 24,000 watts, which may not power your entire home or farm outbuilding -- you must work with the installing electrician to determine which devices/appliances you wish to power during an outage. The electrician can help you determine which circuits and devices can be powered simultaneously without overloading the generator.

(See the previous section of this manual entitled "Power Load Planning & Management" for more information on load application and selection.)

Using as a Portable Power Source

When using the generator as a portable power source, you can plug electric devices and appliances directly into the generator's electrical outlets.

There are four different kinds of electrical outlets on the generator:

1. One 120/240 Volt, 60 Amp straight-blade receptacle (NEMA 14-60R receptacle compatible with NEMA 14-60P mating plug)
2. One 120/240 Volt, 30 Amp locking receptacle (NEMA L14-30R locking receptacle compatible with L14-30P mating plug)
3. Two 120 Volt, 20 Amp duplex straight-blade receptacles (NEMA 5-20R duplex receptacles compatible with NEMA 5-20P or 5-15P mating plugs).
4. One 120/240 Volt, 100 Amp receptacle. This extremely safe and durable receptacle can be used for all large loads, including transfer switches. To utilize this receptacle, specific connectors and contacts must be used. A connector assembly for use with this receptacle can be ordered from NorthStar at 1-800-270-0810 (NorthStar Part #37552).

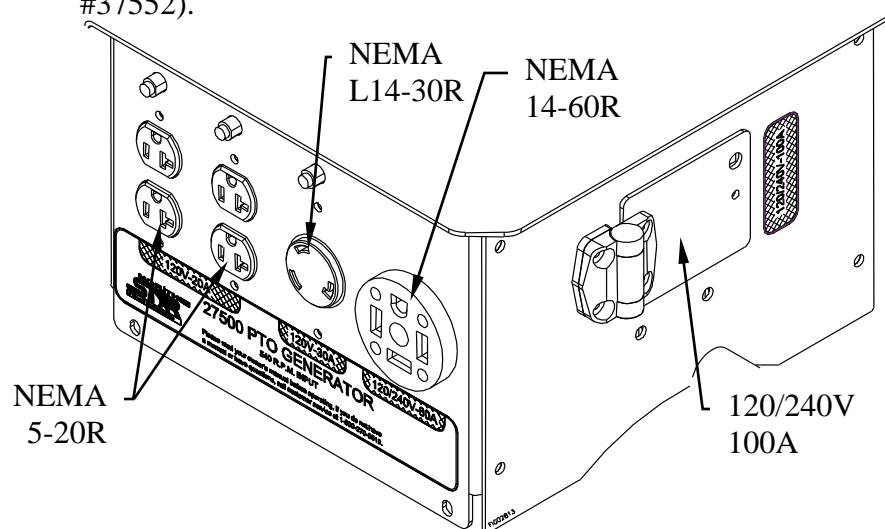

Installation / Initial Set-Up

(See more technical detail about these receptacles and their associated circuit breakers in the “Machine Component Identification” section of this manual.)

- ◆ Make sure you plug each electrical device/appliance into the correct generator outlet based on the device’s plug configuration and voltage/amperage rating. Never exceed the amperage rating of an outlet.
- ◆ Extension cords may be used to power devices that are located at a distance from the generator. However, use only UL-listed, outdoor-rated, grounded extension cords of the proper size. Additionally, if using the generator in damp or highly electrical conductive areas or on construction jobsites, always use ground fault circuit interrupter (GFCI)-equipped extension cords to prevent electrical shock. Use Table 5 below to choose an adequately sized extension cord according to the amperage of the device being used and the length of the cord.

Table 5

Current/Power		Maximum Extension Cord Length			
Amps at 240V	Load (watts)	#10 Ga. Cord	#12 Ga. Cord	#14 Ga. Cord	#16 Ga. Cord
10	2400	250'	150'	100'	75'
20	4800	125'	75'	50'	25'
30	7200	60'	35'	25'	10'
40	9600	30'	15'	10'	*
50	12000	15'	*	*	*

⚠ WARNING:

Use of under sized extension cords can cause electric shock, fire, or damage to connected devices. Failure to use GFCI extension cords in damp or wet conditions can result in severe electric shock or electrocution.

- ◆ All extension and appliance cords must be in good condition and not worn, bare, frayed, or otherwise damaged.

⚠ WARNING:

Use of damaged electric cords can cause electric shock or fire.

Note: If an extension cord becomes hot to the touch, it is overloaded or damaged and must be replaced.

Northern Tool is NOT responsible for damage or injury resulting from customer use of inadequate extension cords.

Installation / Initial Set-Up

4. Select a Suitable Site

Before using the generator, you must select a suitable **OUTDOOR** location for installation and operation of your generator.

- If you will be mounting the generator to a concrete slab, you must choose the location of the slab according to all the criteria listed below.
- If the generator will be mounted to a trailer, you should follow all the criteria listed below to select a suitable location each time you use the generator.



WARNING:

You must choose a suitable site for operating your generator to avoid equipment damage and/or injury and possible death from carbon monoxide poisoning, electric shock, or fire. Choose a site that meets all of the criteria specified.

Site/Location Criteria:

Dry, level surface	<p>The generator should be positioned on a dry, firm, level surface. Ensure that the generator will sit during operation. Apply the tractor's parking brake, and if trailer-mounted block the trailer's wheels to prevent sliding and shifting.</p>
Outdoors only – dangerous carbon monoxide exhaust	<p>⚠ WARNING: Carbon monoxide poisoning hazard The exhaust from your tractor contains carbon monoxide (CO), a poisonous gas that can kill. You cannot smell it, see it, or taste it. Follow the directions below for choosing a location to operate your generator in order to avoid carbon monoxide poisoning.</p> <p>The location you choose to operate the generator must be OUTDOORS and away from all air intakes:</p> <ul style="list-style-type: none"> ● Never run the generator or tractor inside any closed or semi-enclosed spaces (even if outdoors), including homes, garages, basements, sheds, or boxes. <i>These spaces can trap poisonous gases, even if you run a fan or open windows.</i> ● Place the tractor so that the exhaust fumes will not be directed towards people or building air intakes. ● Ensure that working, battery-operated or battery back-up carbon monoxide alarms are used in any dwelling/structure that is in close proximity to the running generator.
Adequate cooling ventilation	<p>The generator needs adequate, unobstructed flow of air to allow for proper cooling of generator head.</p> <ul style="list-style-type: none"> ● Situate so there is adequate clearance around generator to allow for cooling airflow so that heat does not build up. Never block vent slots. The closest object should be at 7 feet away from vents.

Installation / Initial Set-Up

	<ul style="list-style-type: none"> • Do not run the generator in close proximity to other heat-generating equipment, such as another generator. The combined heat that is generated may raise air temperature in the immediate area and there will not be adequate cooling ventilation. • Do not allow debris to accumulate and block airflow. • Do not operate with a tarp, blanket, or cover surrounding the generator.
Hot tractor exhaust clearance	<p>The exhaust gas from your tractor is extremely hot and can cause combustible materials to catch on fire.</p> <ul style="list-style-type: none"> • Position tractor at a safe distance from all nearby combustible materials and buildings/structures. Refer to your tractor manual to determine the safe clearance distance required for hot tractor exhaust in particular. • Keep a fire extinguisher rated “ABC” nearby. Keep it properly charged and be familiar with its use.
No wet conditions	<p>Choose a location where the generator will NOT be exposed to rain, snow, or direct sunlight. Exposure to water can cause electric shock.</p> <p>You <i>may</i> operate the generator under an outdoor, canopy-like structure of heat-resistant material that is open on all sides. Make sure that all parts of canopy are:</p> <ul style="list-style-type: none"> • at least 7’ from generator • at an adequate safe clearance from hot tractor exhaust. <p>Allow for adequate clearance above generator so that heat from generator does not build up.</p>
Away from dust/dirt	<p>Do not use the generator in extremely dusty or dirty conditions. Excessive dust and dirt can cause premature failure of the machine.</p>
Hearing protection	<p>Generators can produce noise levels of up to 95 dB in close proximity, which can be dangerous to human hearing with prolonged exposure. (This is in addition to the noise produced by the tractor.)</p> <p>Hearing protection may be required for persons working within 15-20 feet of the running generator for an extended period of time.</p>

Installation / Initial Set-Up

5. Mounting the generator

This generator must be securely mounted on a reinforced concrete slab or a PTO generator trailer before it is connected to your tractor's PTO.* This will prevent the generator from flipping due to the rotational torque of the PTO.

The slab or trailer you use must be of adequate size and strength to withstand up to 358.7 pound-foot of operating torque without flipping or structural failure.

⚠ WARNING: Failure to properly mount and secure the generator may cause the unit to flip violently during use, which could cause severe injury to the operator or bystanders, or damage to surrounding objects.

Failure to properly mount the generator is not only unsafe, but will void the manufacturer's warranty.

* Instructions for connecting generator to tractor PTO are provided later in this manual in the **Operation** section, "Step 3. Connecting to the Tractor".

Mounting to a trailer

Mount to a trailer if you plan to use the generator as a portable source of power.

⚠ WARNING:

Never mount to a trailer that is not wide enough or strong enough to handle the operating torque. An inadequate trailer may flip or fail due to generator's operating torque, potentially causing injury or death.

1. Use only a wide base trailer that is specifically designed for mounting a PTO generator.
 - A PTO generator trailer is designed to be of adequate size and strength to withstand the generator's operating torque without flipping or structural failure.
 - The trailer wheel base must be wide enough to prevent flipping.
 - The trailer base must be constructed of thick enough steel to prevent metal fatigue from the constant vibration of the generator.
 - A trailer specifically designed for use with PTO generators rated up to 60,000 Watts is available from NorthStar -- Item #165959.
 2. Mount the generator on the trailer so it is:
 - Balanced forward of the trailer axle to prevent the trailer from tipping backward.
 - Centered side-to-side between the trailer's wheels to minimize the possibility the trailer will flip due to operating torque.
- If using the NorthStar PTO trailer (Item #165959), specific mounting bolt patterns are illustrated in the trailer's Owner's Manual for various NorthStar PTO generator models.

Installation / Initial Set-Up

3. Bolt the generator to the trailer base using six, 1/2" grade 5 bolts. See Figure 6.

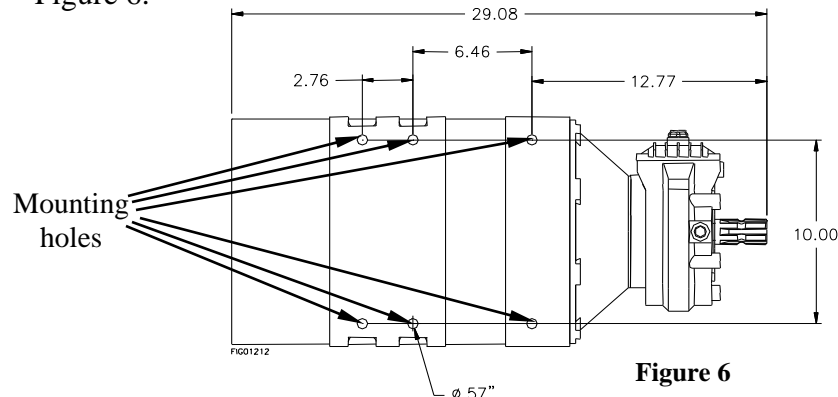

Note: In order to access two of the mounting holes, you will need to remove the louvered, fan vent panels on both sides. ALWAYS replace panels before starting the generator.

Mounting to a concrete slab

If you will be using the generator in a permanent location, you may mount the generator to a reinforced concrete slab.

1. Choose a location for the slab that is as close to the load as possible (to minimize voltage drop) and which also meets all the criteria specified in the previous section, “**4. Select a Suitable Location**”.
2. The slab must:
 - Be of adequate size and weight to properly anchor the generator and resist flipping under operating torque. Typically the slab will need to be at least 2 feet x 2 feet x 4 inches thick.
 - Be reinforced with rebar in a direction perpendicular to the PTO shaft. Rebar will strengthen the concrete to resist cracking and breaking as a result of operating torque and vibration.
 - Provide adequate elevation to ensure that the PTO driveline angle between the generator and tractor will not exceed 15 degrees. **Note:** The smaller the angle, the longer the driveline will last.

For technical guidance on the design and construction of reinforced concrete slabs, refer to the *American Concrete Institute (ACI)* web site at www.concrete.org. The ACI has published several Technical Committee documents concerning the design and construction of concrete slabs.

⚠ WARNING:

Never attempt to mount generator to a slab that is not large enough or strong enough to withstand the operating torque. Slab failure could result in the generator flipping violently and possibly causing injury or death to those nearby.

3. Mount the plates to the concrete slab using six, grade 5, size 1/2" bolts. See Figure 6.

Installation / Initial Set-Up

6. Grounding the generator

Always ensure the generator is properly grounded to prevent electrical shock.

You must always ground the generator by the following method when using the generator as a portable electrical source:

- 1) Drive a $\frac{3}{4}$ " or 1" copper pipe or rod into the ground close to the generator. The pipe/rod must penetrate moist earth – the depth required will be dictated by local soil conditions. Consult with an electrician.
- 2) Connect an approved ground clamp to the pipe.
- 3) Run an 8 gauge wire from the clamp to the generator grounding clamp located on the rear of the generator head.
- 4) Do not connect the generator grounding post to a water pipe or a ground used by a radio system.

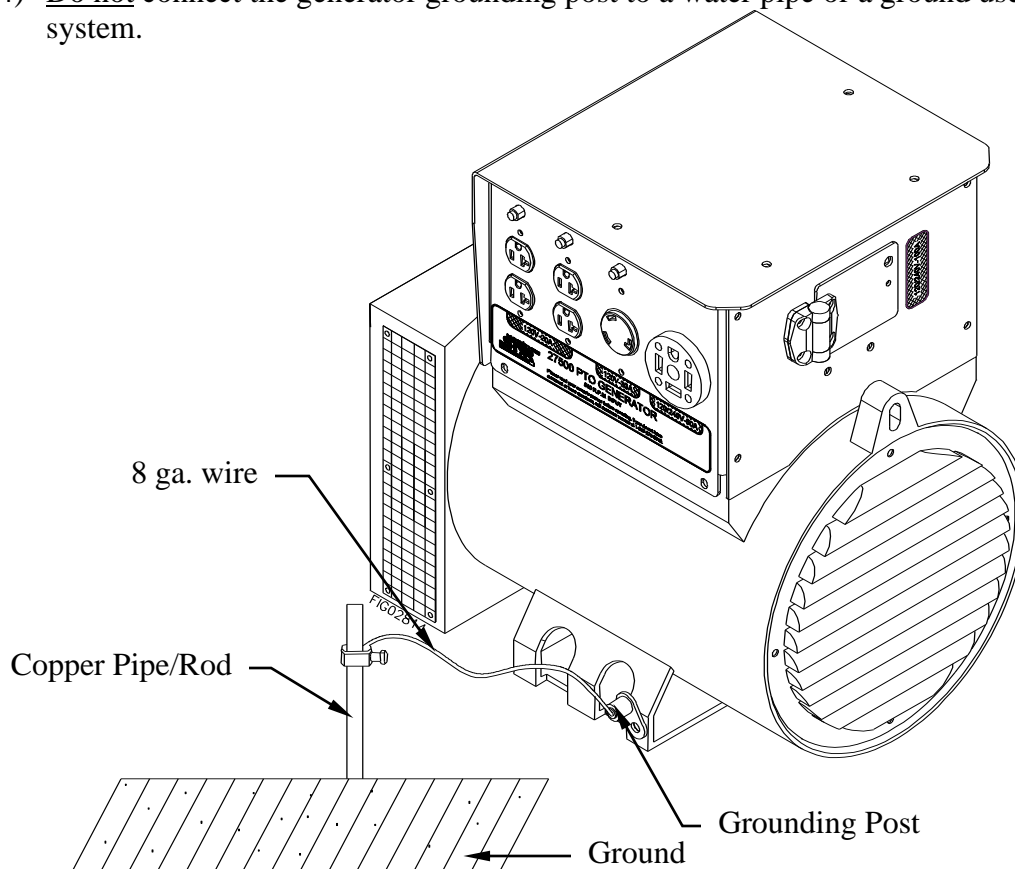

- 5) The generator must be grounded every time it is moved.

If a licensed electrician installs the generator with a connection to your building's electrical circuit for use as a back-up power system, grounding may alternatively be completed through the building's grounding system. Ask your electrician. If the generator is not grounded through your building's electrical system, follow the procedure above.

⚠ WARNING:

Operating the generator when it is not properly grounded can result in electrical shock.

Operation

Once you have set up your generator for use, it is time to start your generator. The following are the procedures necessary for safe, successful operation of your generator.

Operation Procedures

1. **General Safety Rules for Operation**
2. **Preparing for Operation**
3. **Connecting to the Tractor**
4. **Starting the Generator**
5. **Connecting Electrical Loads**
6. **Stopping**
7. **Storage & Exercise of Generator**

Each of these procedures is discussed in detail below:

1. General safety rules for operation

Before starting the generator, review the following general safety rules for operation:

 **WARNING:**

Failure to follow safety rules may result in serious injury or death to the operator or bystanders.

- **Know proper use/how to stop.** Be thoroughly familiar with proper use of the equipment and all generator controls, output receptacles, and connections. Know how to stop the generator quickly if needed.
- **Instruct operators.** The generator owner must instruct all operators in safe generator set-up and operation. Only trained adults should set up and operate the generator – Do not let children operate.
- **Intended use.** Carefully read about and understand the intended use of this generator. Do not use for other purposes, as unforeseen hazards or equipment damage may result.
- **Under the influence.** Never operate, or let anyone else operate, the generator while under the influence of alcohol, drugs, or medication.
- **Safety guards / controls.** Do not operate the generator unless all safety covers, guards, and barriers are in place and in good working order, and all controls are properly adjusted for safe operation
- **Damaged.** Do not operate the generator with damaged, missing, or broken parts.
- **Modifications.** Do not modify the generator in any way. Modifications can create serious safety hazards and will also void the warranty.
- **Malfunction during operation.** Immediately turn off the generator if any of the following conditions arise during operation:
 - Excessive change in tractor engine speed, slow or fast
 - Overheating in load connecting devices
 - Sparking or arcs from generator
 - Loss of electrical output
 - Receptacle damage
 - Excessive vibration

Operation (cont'd)

- Flame or smoke
- Abnormal noise
- **Adjusting / repairing.** Always turn off generator and remove PTO driveline before working on the generator. Always discharge the capacitor before working on the generator head to prevent electrical shock. (See Maintenance & Repair section of this manual for instructions on how to do this.)
- **Carbon monoxide poisoning.** The running tractor engine gives off carbon monoxide, a poisonous gas that can kill you. You CANNOT smell it, see it, or taste it. Follow all instructions for site selection and positioning the tractor and generator, and avoid inhaling the exhaust. If you start to feel sick, dizzy, or weak, shut off the tractor and get to fresh air RIGHT AWAY. See a doctor. You may have carbon monoxide poisoning.
- **Electrical cords.** Use only UL-listed, outdoor-rated, three prong extension cords of the proper size. All extension and appliance cords must be in good condition and not worn, bare, frayed, or otherwise damaged. Use of inadequate or damaged electric cords can cause electric shock or fire.
- **GFCI extension cords.** Always use ground fault circuit interrupter (GFCI)-equipped extension cords in damp or highly electrical conductive areas and on construction jobsites to prevent electrical shock.
- **Avoid contact.** Avoid contact with bare wires, terminals, connections, etc. while the unit is running.
- **Wet conditions.** Do not operate the generator or handle any electrical equipment while standing in water, while barefoot, while hands are wet or while in the rain or snow. Electric shock may result.
- **Electric shock accident.** If an electric shock accident occurs, immediately shut down the source of electrical power. If this is not possible, attempt to free the victim from the live conductor. Avoid direct contact with victim. Use a nonconducting implement, such as a dry rope or board, to free the victim from the live conductor. Apply first aid and get immediate medical help.
- **Smoking/sparks.** Never smoke near the running generator, and never operate near sources of sparks or flames.
- **Hot parts.** Parts of the generator are extremely hot during and after operation and can burn you. Never touch hot gearbox, and do not touch any other part of the generator unless you have first determined if it is hot. Wait a sufficient time for parts to cool before touching any part of the generator.
- **Moving parts.** Keep hands, feet, and apparel away from PTO connections, drive shaft, belts, fans, and other moving parts. Never attempt to remove drive shaft or any guard or shield while the unit is operating.

Operation (cont'd)

2. Preparing for Operation

Mount generator	<p>Make sure the generator is mounted in accordance with instructions given in “Installation / Initial Set-up section, Step 5: Mounting the Generator” of this manual.</p> <p>⚠ WARNING: Always ensure generator is properly mounted to prevent it from flipping during use, which could cause equipment damage and injury to nearby persons.</p>
Position generator	<p>Position tractor and generator in accordance with the instructions given in “Installation / Initial Set-up section, Step 4: Select a Suitable Site” of this manual. Operate outside only, on dry, level ground with adequate clearance and ventilation. Apply parking brake, and block trailer wheels if generator is trailer-mounted.</p> <p>⚠ WARNING: Carbon monoxide poisoning hazard The tractor engine gives off carbon monoxide exhaust, a poisonous gas that can kill. You CANNOT smell it, see it, or taste it. ONLY run generator OUTDOORS and away from air intakes. NEVER run tractor and generator inside any enclosed or semi-enclosed spaces, including homes, garages, basements, sheds, boxes, pick-up truck beds, RVs, or boats. These spaces can trap poisonous gases, EVEN if you run a fan or open windows.</p>
Ground generator	<p>Make sure the generator is grounded in accordance with instructions given in “Installation / Initial Set-up section, Step 6: Grounding the Generator” of this manual.</p> <p>⚠ WARNING: Electric shock hazard Always ensure generator is properly grounded to prevent electrical shock.</p> <p>IMPORTANT: The generator must be grounded every time it is moved.</p>
Perform regular maintenance	<p>Make sure that any regular maintenance has been performed as prescribed in this manual in the “Maintenance & Repair” section.</p>
Check/add oil	<p>Check the gear box oil level and add oil as needed.</p> <ol style="list-style-type: none"> 1. First time use only: If you have not already done so, remove the temporary shipping plug from the oil port and replace with the metal breather/oil fill plug that is in the manual bag. 2. Check oil level using the sight mounted on the gearbox. When oil level is even with the red dot, the oil level is correct. 3. If oil needs to be added, remove the filler/breather plug at the top of the gearbox. Use SAE 90W gear oil to refill so that oil level is even with the red dot. Do not overfill. Overfilling can cause the oil to overheat and cause damage to generator.

Operation (cont'd)

	<p>⚠ WARNING: Burn hazard Never open oil port while generator is running. Hot oil can spray over face and body.</p> <p>IMPORTANT: Under long, continuous-run operating conditions, be prepared to:</p> <ul style="list-style-type: none"> • Check gear oil level daily. • Change gear oil monthly (see instructions in “Maintenance & Repair” section of this manual).
<p>Personal Protection</p>	<ol style="list-style-type: none"> 1) Hearing can be damaged from prolonged, close-range exposure to the type of noise produced by this generator. The use of ear plugs or other hearing protection device is recommended for persons working within 15-20 feet of the running generator for an extended period of time. 2) Loose or dangling apparel and long hair can become quickly entangled in moving/rotating parts. Metal jewelry can conduct electricity. Never wear jewelry or loose-fitting clothing such as neckties, scarves, or long-sleeved or untucked shirts when starting or adjusting the generator. Tie back and secure hair close to the head.

3. Connecting to the Tractor

Follow the instructions in this section to connect the generator to the tractor’s PTO via a driveline shaft (purchased separately).

Acquire PTO driveline shaft

Acquire a synchronized 1-3/8”, 6 spline PTO driveline rated at 24 HP minimum.

A suitable PTO driveline, available from Northern Tool (*Item #165936*), includes the following advanced safety features:

- A telescoping shaft
 - to provide flexible accommodation of mounting distance between tractor and generator
 - to allow for dynamic compression and stretching while turning or driving a trailer-mounted generator over uneven ground.
- Protrusion-free end yokes with slide collars that lock into place.
- An internal cable stop to prevent separation of driveline halves.
- A non-rotating tubular shaft guard with anchoring chain, plus shield cones that cover the rotating yokes with a 2” overlap
- Grease zerks to allow for proper lubrication of driveline joints.

It is strongly recommended that any driveline utilized have these safety features.

Operation (cont'd)

Attach PTO driveline shaft

Connect the PTO driveline shaft to the tractor and generator:

1. Align the tractor and generator to minimize the driveline angle in both the horizontal and vertical planes; it should be as near to a direct line in all directions as possible. The angle should never exceed 15° in any direction.

Note: Proper alignment will increase the life of the power takeoff shaft, reduce wear on the bearings of the PTO and generator, and reduce vibration.

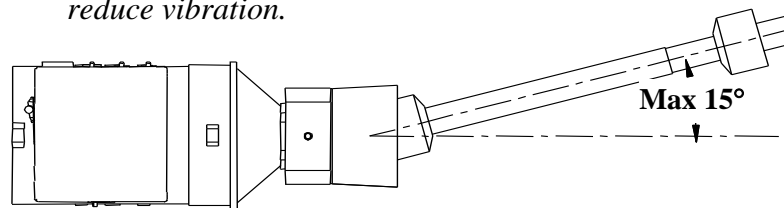

Top View

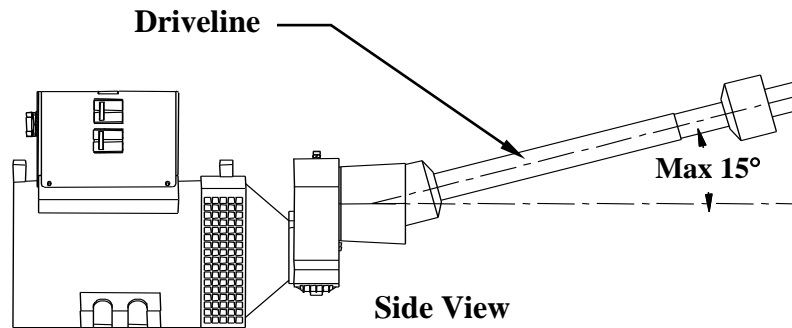

Side View

2. Ensure that the tractor PTO is disengaged and the tractor is turned OFF.
3. Connect one end of the PTO driveline shaft to the generator's input shaft.
4. Connect the other end to the tractor PTO stub.

⚠ WARNING:

Make sure PTO driveline shaft is securely locked at both ends. Unlocked PTO shafts can whip or become dangerously airborne.

Secure driveline guard & check shields

1. A driveline GUARD must ALWAYS be used with the driveline shaft. Secure the driveline guard according to manufacturer's instructions.
2. Make sure the tractor and generator shields are in place at both ends of the driveline shaft:
 - On the tractor where the driveline connects to the PTO stub
 - On the generator where the driveline connects to the input shaft.

⚠ WARNING:

Never operate the generator without proper PTO guarding, including a freely rotating shaft guard as well as tractor and generator shields at both ends. Clothing or hair can become rapidly entangled in unguarded rotating PTO shaft or connections, resulting in *serious injury or death*.

Operation (cont'd)

4. Starting the Generator

To start the generator:

1. Start the tractor with the PTO control in the “disengaged” position.
2. While seated on the tractor and the engine at idle, engage the PTO.
3. Slowly increase the throttle until the needle in the generator voltmeter is at or above the black line in the green area.

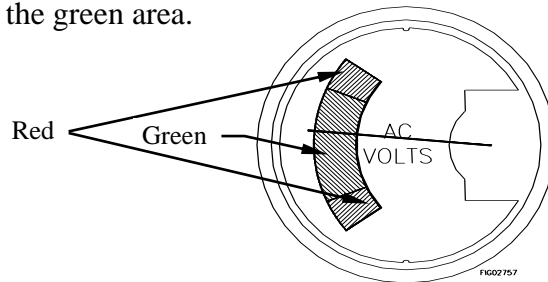

5. Connecting Loads

You will want to be careful when connecting loads so as not to overload the generator, especially if you are powering devices with motors that require a higher starting power load.

Instructions are provided below for connecting loads when you are using the generator:

- As a portable power source
- Connected to a building as a back-up power source

⚠ WARNING:

Do not overload generator. Make sure that combined starting and running loads do not exceed rated capacity of generator. Overloading the generator can cause damage to the generator and attached electrical devices, and may result in fire.

Using as a Portable Power Source

Connect electrical loads one at a time according to the following instructions:

1. Allow engine to reach operating speed by allowing it to warm up for approximately 5 minutes before connecting electrical devices.
2. After engine is warmed up, begin connecting the loads one at a time.

⚠ WARNING: Stay clear of the rotating PTO driveline!

Start with those that require the highest wattage first. The recommended sequence is as follows:

- a. Connect items with motors such as refrigerators, freezers, air conditioners, or small hand tools, one at a time. Let each motor stabilize before connecting the next device.
- b. Connect any lights you are planning on powering.
- c. Connect voltage sensitive equipment such as electronics via surge protectors. Plug devices such as TV's, computers, and microwaves into a UL listed voltage surge protector, then plug the surge protector into the generator.

Operation (cont'd)

3. After connecting each load, return to the driver's seat. Readjust the throttle until the needle on the generator's voltmeter is close to the black line in the green area.
- If the needle will not rise to the green area no matter what the engine speed, the generator is either overloaded or there is a problem.
 - Shut off the tractor and refer to the Troubleshooting guide at the end of this manual for assistance with possible problems.

Also check your tractor's PTO rating to make sure it is capable of producing a minimum of 24 HP at 540 RPM. This is not necessarily equivalent to the HP rating for the tractor itself.

 WARNING:

The generator must be run at the correct speed in order to produce the proper electrical voltage and frequency. Failure to do so could result in damage to equipment powered by the generator and possible injury to the individual.

Note: *All engines have a tendency to slow down when a load is applied. When electrical loads are connected to the generator, the engine is more heavily loaded and as a result the speed drops slightly. This slight decrease in speed, together with the voltage drop within the generator itself, results in a slightly lower voltage when the generator is loaded to its full capacity than when it is running with no load. Additionally, there may be small brief surges and drops in voltage as motors connected to the generator cycle on or off. The slight variation in voltage, as long as the needle remains in the green area, has no appreciable effect in the operation of motors, lights, and most appliances.*

Using as a Back-up Power Source for a Building

Each transfer switch installation will be unique. Proper instructions for how to safely bring the generator online with the building's electrical system should be provided by the installing electrician, who should also provide personal instruction to the owner/operator.

Failure to follow the proper procedure as provided by the electrician could expose persons to the hazards noted above.

Note: After you have brought the generator online with the transfer switch, you will need to adjust the tractor's throttle speed to maintain correct output voltage under load. Adjust the throttle until the needle on the generator's voltmeter is close to the black line in the green area. (See more detail about maintaining proper voltage in the instructions given above for using the generator as a portable power source.)

Operation (cont'd)

6. Stopping

Stop the generator using the following steps:

1. Disconnect all loads to generator. (Never reduce throttle with electrical loads connected. Damage to generator and loads will occur.)
2. After all loads are disconnected, slowly reduce PTO speed to a minimum and then disengage PTO.
3. Shut OFF the tractor engine.
4. Remove the PTO driveline shaft from generator and tractor.

7. Storage & Exercise

When you are finished using the generator, you must:

- Disconnect all loads and PTO driveline
- Store the generator properly
- Plan on exercising the engine regularly

Detailed instructions are provided below.

Disconnect loads & PTO	<p>When you are finished using the generator:</p> <ol style="list-style-type: none"> 1. Make sure all loads are disconnected from generator's outlets. 2. Make sure the generator is disconnected from the PTO.
Store in appropriate location	<ol style="list-style-type: none"> 1. Let generator cool for at least five minutes before storing. Hot equipment can be a fire hazard near combustible materials. 2. Store the generator in a location that is: <ul style="list-style-type: none"> ○ Clean and dry. It is important to keep the generator windings free of moisture. ○ Away from extreme high or low temperatures.
Exercise generator every 4 weeks	<p>The generator should be exercised regularly.</p> <p>At least every four weeks, start the generator and let it run for 10 to 15 minutes.</p> <p>Monthly exercising of the generator will:</p> <ul style="list-style-type: none"> ○ Dry out any moisture that has accumulated in the windings. If left, this moisture can cause corrosion in the winding. ○ Ensure that the unit is operating properly should it be needed in an emergency.
Perform regular maintenance	<p>Perform periodic maintenance as directed in this manual to keep the generator in safe working condition.</p>

Maintenance & Repair

Inspect and maintain your generator as specified below in order to keep it in safe and optimal working order. Follow all safety rules and recommended maintenance steps.

 WARNING

ALWAYS shut off the engine, remove PTO driveline and discharge the capacitor before cleaning, adjusting, or servicing the generator. Make sure all guards and shields are replaced before using.

Note: The generator head is brushless and maintenance free. The bearing is a heavy-duty sealed ball bearing which requires no maintenance or lubrication.

Maintenance & Repair

Follow safety rules	<p>Read and follow these safety rules whenever you will be servicing the generator:</p> <ul style="list-style-type: none"> • Turn off generator. Always stop tractor engine and remove PTO driveline before working on the engine or generator to prevent accidental starting. • Discharge capacitor. When the generator is shut down, the capacitor may maintain a charge. Always discharge the capacitor before working on the generator head to prevent electrical shock. Discharge using a screwdriver with an insulated handle. While wearing safety glasses, touch opposite terminals of the capacitor together with the tip of the screwdriver. If there is stored charge in the capacitor, a spark will be generated thereby discharging the capacitor. • Replace guards. Make sure all guards and shields are replaced after servicing the generator. • Repair. Major service, including the installation or replacement of parts, should be performed only by a qualified electrical service technician. Obtain factory approved parts from Northern Tool Product Support at 1-800-270-0810. • Replacement parts. If a part needs replacement, only use factory approved repair parts. Replacement parts that do not meet specifications may result in a safety hazard or poor operation of the generator and will void the warranty.
Maintain gear oil	<p>Check the gear oil level before each use and add oil as needed. Change gear oil every year.</p> <p style="text-align: center;"> WARNING: Burn hazard Never open oil port while generator is running. Hot oil can spray over face and body.</p> <ol style="list-style-type: none"> 1. Check/add oil before each use: <ol style="list-style-type: none"> a. Check oil level using the sight mounted on the gearbox. When oil level is even with the red dot, the oil level is correct. b. If oil needs to be added, remove the filler/breather plug at the top of the gearbox. Use SAE 90W gear oil to refill so that oil level is even with the red dot. Do not overfill. Overfilling can cause the oil to overheat and cause damage to generator.

Maintenance & Repair (cont'd)

	<p>2. Change oil every year:</p> <ol style="list-style-type: none"> a. Drain oil from gearbox (drain plug is underneath gearbox). b. Replace drain plug. c. Refill with SAE 90W gear oil. Refill so that oil level is even with the red dot. <p><i>IMPORTANT:</i> Under long, continuous-run operating conditions, be prepared to add and change oil more frequently:</p> <ul style="list-style-type: none"> • Check gear oil level daily. • Change gear oil monthly.
Check receptacles	<p>Check receptacles before each use to make sure they are not cracked or broken.</p> <p>If a receptacle is cracked or otherwise damaged, do not use until replaced with an authorized factory part. Using cracked or damaged receptacles can be both dangerous to the operator and destructive to the equipment.</p>
Keep generator clean	<p>Keep generator clean.</p> <p>If dust or debris accumulates on the generator, clean the generator with a damp cloth or soft bristle brush. Do not allow air intakes to become blocked.</p> <p><u>Note:</u> Do not spray generator with a garden hose or pressure washer. Water may enter the generator and cause damage to the rotor, stator, or internal windings.</p>

IMPORTANT:

If a part needs replacement, only use parts that meet the manufacturer's specifications. Replacement parts that do not meet specifications may result in a safety hazard or poor operation of the generator.

Contact NorthStar Product Support at 1-800-270-0810 for any questions, problems, or parts orders.

Troubleshooting

TROUBLESHOOTING		
<u>Problem</u>	<u>Possible Causes</u>	<u>Possible Remedies</u>
Voltage too low.	<ul style="list-style-type: none"> a) Engine speed too slow. b) Generator is overloaded. 	<ul style="list-style-type: none"> a) Increase tractor RPMs. b) Reduce the load. (See Power Load Planning & Mgt section of this manual.)
Circuit breaker trips.	<ul style="list-style-type: none"> a) Defective load connected to generator. b) Defective receptacle. c) Generator overloaded. d) Defective circuit breaker. 	<ul style="list-style-type: none"> a) Disconnect load. b) Replace receptacle. c) Reduce the load. (See Power Load Planning & Mgt section of this manual.) d) Contact Customer Service for the nearest service center.
Voltage too high.	<ul style="list-style-type: none"> a) Engine speed too high. 	<ul style="list-style-type: none"> a) Contact Customer Service for the nearest service center.
Generator overheating.	<ul style="list-style-type: none"> a) Generator is overloaded. b) Insufficient ventilation. 	<ul style="list-style-type: none"> a) Reduce the load. (See Power Load Planning & Mgt section of this manual.) b) Make sure there is at least 7 feet of clearance on all sides of generator.
No output voltage.	<ul style="list-style-type: none"> a) Defective load connected to generator. b) Broken or loose wire. c) Defective receptacle. d) Defective stator. e) Defective rotor. f) Defective capacitor. g) Defective circuit breaker. h) Engine speed too slow. i) PTO not engaged. j) Gear box is malfunctioning. k) Circuit breaker tripped. 	<ul style="list-style-type: none"> a) Disconnect load. b) Replace wire. c) Replace receptacle. d) Contact Customer Service for the nearest service center. e) Contact Customer Service for the nearest service center. f) Contact Customer Service for the nearest service center. g) Contact Customer Service for the nearest service center. h) Increase tractor RPMs. i) Engage PTO. j) Contact Customer Service for the nearest service center. k) Reset circuit breaker and reduce loads connected to the generator.
Excessive gear box noise.	<ul style="list-style-type: none"> a) Defective bearing. b) Defective gear. c) No or low gear oil. d) PTO drive line is operating at an angle of greater than 15°. e) Unsynchronized PTO drive line. 	<ul style="list-style-type: none"> a) Contact Customer Service for the nearest service center. b) Contact Customer Service for the nearest service center. c) Fill gear box to oil level sight. d) Reposition the tractor or generator so the angle is reduced to less than 15° both vertically and horizontally. e) Disassemble PTO driveline and reassemble with CV joints synchronized.

Summary of Important Safety Information for Operation

This section provides a summary of the various safety procedures and measures that have been presented throughout the manual. Keep this summary handy and refer to it to refresh your memory about how to safely use your generator.

WARNING

Carefully read and make sure you understand the following safety information before using the generator.

Improper use or maintenance of the generator can result in *serious injury or death* from *carbon monoxide poisoning, electric shock, entanglement, fire, or burns*. In addition, *PTO shaft and generator can become airborne and cause severe injury* if improperly secured.

General

- **Read manual.** Read this Owner's Manual and the engine Owner's Manual completely before attempting to set-up and use the generator. Serious injury or death can result if safety instructions are not followed.
- **Instruct operators.** The generator owner must instruct all operators in safe generator set-up and operation. Do not allow anyone to operate the generator who has not read the Owner's Manual and been instructed on its safe use.
- **Adults only.** Only trained adults should set up and operate the generator. Do not let children operate.
- **Under the influence.** Never operate, or let anyone else operate, the generator while under the influence of alcohol, drugs, or medication.
- **Intended use.** Carefully read about and understand the intended use of this generator. Do not use for other purposes, as unforeseen hazards or equipment damage may result.

Prohibition Against Modifications

- **Modifications prohibited.** Never modify or alter the generator in any way. Modifications can create serious safety hazards and will also void the warranty.
- **Guards.** Do not operate generator unless all guards and cover shields, which prevent access to moving parts and pinch points, are in place. Failure to guard the power transmission mechanisms *may result in serious injury or death*.

Safety – Installation & Set-up

- **Mount generator.** Failure to properly mount and secure the generator may cause the unit to flip violently during use, which could cause severe injury to the operator or bystanders, or damage to surrounding objects.
 - The generator must be securely mounted to either a reinforced concrete slab or a trailer.
 - Slab or trailer must be of adequate size and strength to withstand operating torque without flipping or structural failure.
 - See the "Installation / Initial Set-Up" section of this Owner's Manual for mounting requirements and instructions.
- **Dry, level surface.** Situate generator on a dry, firm, level surface. Ensure generator sits level and will not slide or shift during operation. Apply parking brake, and block trailer wheels if generator is trailer-mounted.
- **Operate OUTSIDE only – dangerous carbon monoxide exhaust!** The running tractor gives off carbon monoxide exhaust, a poisonous gas that can kill. You CANNOT smell it, see it, or taste it. ONLY run generator OUTDOORS and away from building air intakes. NEVER run generator inside homes, garages, sheds, or other semi-enclosed spaces. These spaces can trap poisonous gases, EVEN if you run a fan or open windows
- **Cooling ventilation.** The generator needs adequate, unobstructed flow of air to allow for proper cooling of engine and generator head so it does not overheat and possibly cause fire. Situate so there is adequate clearance around generator to allow for cooling airflow. Do not allow debris to accumulate and block airflow. Keep all objects at least 7 feet away from vent slots.
- **Grounding.** Always ensure generator is properly grounded to prevent electrical shock. This generator is equipped with a grounding post. Always complete the grounding path from the generator to a copper pipe/rod driven into moist earth to a sufficient depth. Check with an electrician for local grounding requirements. If a licensed electrician installs the generator with a connection to your building's electrical circuit for use as a standby power system, grounding will be complete through the building's grounding system.

Summary of Important Safety Information for Operation (cont'd)

- **Isolate connection to building's electrical circuit.** Never plug the generator directly into a wall outlet. ANY connection to a building's electrical system **MUST ISOLATE THE GENERATOR FROM UTILITY POWER** via an UL-approved transfer switch installed by a licensed electrician in compliance with all applicable local building and electrical codes. If the generator is not isolated from the utility power system by such means, generator output will back feed into the utility power grid. This may result in injury or death to utility power workers or others who contact the lines during a power outage. It may also cause the generator to explode or cause fires when utility power is restored.
- **Wet conditions.** Water conducts electricity. Do not operate generator where it is wet. Operate on a dry surface under an open, canopy-like structure.
- **CO alarms.** Ensure that working, battery-operated or battery back-up carbon monoxide alarms are used in any dwelling/structure that is in close proximity to the running generator.
- **Hot tractor exhaust.** Tractor exhaust can be extremely hot and cause fire. Refer to your tractor manual to determine safe clearance distance required between hot tractor exhaust and nearby combustible objects.
- **Fire extinguisher.** Keep a fire extinguisher rated "ABC" by the National Fire Protection Association nearby. Keep it properly charged and be familiar with its use.

Safety – Before Use

Know how to operate

- **Review safety rules.** Before each use of this generator, review the "Rules for Safe Operation." Failure to follow these rules may result in serious injury or death.
- **Know how to operate.** Be thoroughly familiar with all controls and with the proper use of the equipment. Know how to stop the generator quickly if needed.

Personal protective equipment

- **Hearing protection.** The use of ear plugs or other hearing protection device is recommended for those in close proximity to the generator while it is operating.
- **No loose / dangling apparel.** Loose or dangling apparel and long hair can become entangled in moving/rotating parts. Metal jewelry can conduct electricity. Never wear jewelry or loose-fitting clothing such as neckties, scarves, or long-sleeved or untucked shirts when operating the generator. Tie back hair and secure close to head.

Safety – During Use

- **Safety equipment / controls.** Always operate the generator with all safety covers, guards, and barriers in place and in good working order, and all controls properly adjusted for safe operation.
- **Know how to stop.** Be thoroughly familiar with proper use of the equipment and all generator controls, output receptacles, and connections. Know how to stop the generator quickly if needed.
- **Damaged.** Do not operate the generator with damaged, missing, or broken parts.
- **Carbon monoxide exhaust.** The running tractor engine gives off carbon monoxide, a poisonous gas that can kill you. You **CANNOT** smell it, see it, or taste it. If you start to feel sick, dizzy, or weak while using the generator, shut off the tractor and get to fresh air **RIGHT AWAY**. See a doctor. You may have carbon
- **Smoking/sparks.** Never smoke near the running generator, and never operate near sources of sparks or flames.
- **PTO shaft secured.** Make sure PTO driveline shaft is securely locked at both ends. An unlocked PTO shaft can whip or become dangerously airborne.
- **PTO guards.** Never operate the generator without proper PTO guarding, including a freely rotating shaft guard as well as tractor and generator shields at each end. Clothing or hair can become rapidly entangled in unguarded rotating PTO shaft or connections, resulting in **serious injury or death**.
- **Driveline angle.** Never operate the generator continuously when the PTO driveline shaft is at an angle greater than 15° either horizontally or vertically.
- **Check output voltage.** Check output voltage to ensure the generator is working properly before connecting loads to the generator. Failure to do so could result in damage to equipment powered by the generator and possible injury to the individual. Do not adjust output speed of engine to change voltage. If voltage is not within specified range, have generator repaired by factory authorized personnel.
- **Stabilize before connecting loads.** Start generator and let engine stabilize before connecting electrical loads.
- **Do not overload.** Do not overload the generator. Make sure that combined starting and running loads do not exceed rated capacity of generator or damage will result.
- **Protect sensitive electronics.** Some electronic equipment, such as computers and audio/video equipment, can be damaged by small fluctuations in the flow of power. Use a surge suppressor for any voltage-sensitive electronic equipment you will be powering with the generator.

Summary of Important Safety Information for Operation (cont'd)

- **Electrical cords.** Use only UL-listed, outdoor-rated, three prong extension cords of the proper size. All extension and appliance cords must be in good condition and not worn, bare, frayed, or otherwise damaged. Use of inadequate or damaged electric cords can cause electric shock or fire.
- **GFCI extension cords.** Always use ground fault circuit interrupter (GFCI)-equipped extension cords to prevent electrical shock in damp or highly electrical conductive areas and on construction jobsites.
- **Wet conditions.** Do not operate the generator or handle any electrical equipment while standing in water, while barefoot, while hands are wet or while in the rain or snow. Electric shock may result.
- **Avoid contact.** Avoid contact with bare wires, terminals, connections, etc. while the unit is running.
- **Electric shock accident.** If an electric shock accident occurs, immediately shut down the source of electrical power. If this is not possible, attempt to free the victim from the live conductor. Avoid direct contact with victim. Use a nonconducting implement, such as a dry rope or board, to free the victim from the live conductor. Apply first aid and get immediate medical help.
- **Hot parts.** Parts of the generator are extremely hot during and after operation and can burn you. Never touch hot gearbox, and do not touch any other part of the generator unless you have first determined if it is hot. Wait a sufficient time for parts to cool before touching any part of the generator.
- **Moving parts.** Keep hands, feet, and apparel away from PTO connections, drive shaft, belts, fans, and other moving parts. Never attempt to remove drive shaft or any guard or shield while the unit is operating.
- **Malfunction during operation.** Immediately turn off the generator if any of the following conditions arise during operation:
 - Excessive change in tractor engine speed, slow or fast
 - Overheating in load connecting devices
 - Sparking or arcs from generator
 - Loss of electrical output
 - Receptacle damage
 - Excessive vibration
 - Flame or smoke
 - Abnormal noise
- **Adjusting / repairing.** Always turn off generator and remove PTO driveline before working on or cleaning the generator.

Safety – After use

- **Driveline removed.** Always stop tractor engine and remove driveline after use.
- **Cool before storing.** Let generator cool for at least five minutes before storing. Hot equipment can be a fire hazard near combustible materials.
- **Storage location.** Store the generator in a dry location.
- **Exercise regularly.** Exercise generator every four weeks to dry out moisture that accumulates in the windings. If generator cannot be exercised on a regular basis, prepare generator for long term storage.
- **Periodic maintenance.** Perform periodic maintenance as directed in this manual to keep the generator in safe working condition.

Safety - Inspection/Maintenance

Inspect and maintain your generator on a regular basis and repair as needed to keep it in safe working condition:

- **Generator off & driveline detached.** Always stop tractor engine and remove PTO driveline before working on or cleaning the generator.
- **Discharge capacitor.** When the generator is shut down, the capacitor may maintain a charge. Always discharge the capacitor before working on the generator head to prevent electrical shock.
- **Clear debris/deposits.** Keep generator head and moving parts clean. This will ensure the generator is in safe working condition.
- **Replace guards / shields.** Make sure all guards and shields are replaced after servicing the generator.
- **Replacement parts.** If a part needs replacement, only use parts that meet the manufacturer's specifications. Replacement parts that do not meet specifications may result in a safety hazard or poor operation of the generator and will void the warranty.

Generator Exploded View Rev - I

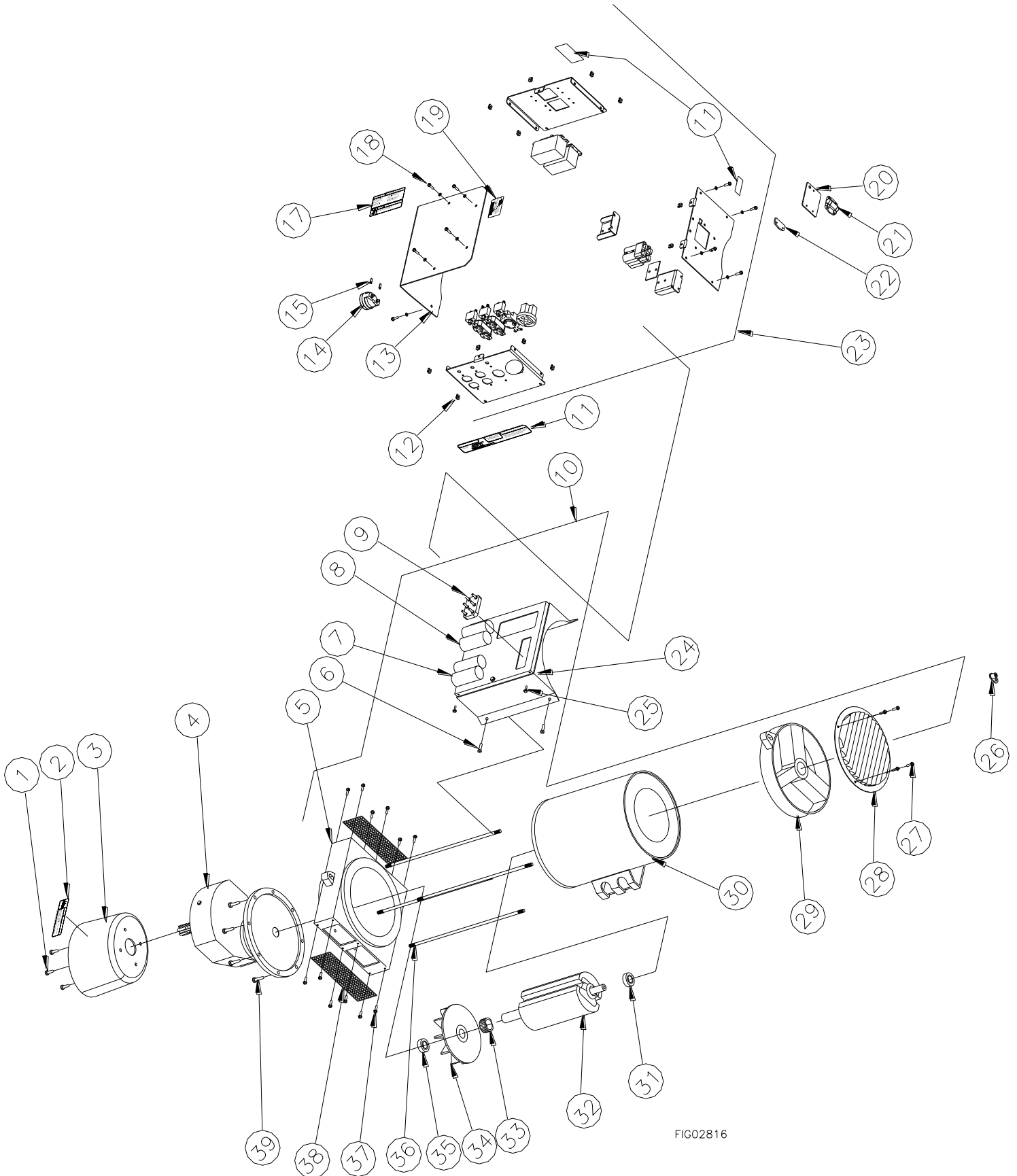

FIG02816

Generator Exploded View Rev – I

Diag #	Part #	Description	Qty
1	32794	M8 X 16mm long HHCS	4
2	779770	PTO Danger Decal	1
3	32756	Implement Shield	1
4	32763	Gear Box	1
5	37619	Drive End Bracket	1
6	33406	M8 X 20mm long SHCS	4
7	9910303129	Capacitor-35 Micro Farad	-
8	9910303140	Capacitor-40 Micro Farad	-
9	37606	Terminal Block	1
10	36766	Generator Assembly	1
11	36854	Decal, Receptacles / Circuit Breaker	1
12	82067	Clip Nut, #10-32	12
13	777321	Box Cover	1
14	31727	Voltmeter	1
15	32755	#10 Ring / Tab	2
17	779781	General Warning Decal	1
18	82007	#10-32 X .75" Screw	12
19	32803	Nameplate	1
20	777322	Receptacle Door	1
21	777201	Hinge	1
22	777203	Hinge Offset	1
23	Refer to Wiring Diagram	Control Panel Assembly	1
24	37605	Terminal Box	1
25	33413	M6 X 10mm long HHCS	4
26	32754	Grounding Post	1
27	37609	M6 X 20mm long SHCS	4
28	37608	Grill	1
29	37607	Non-Drive End Bracket	1
30	37611	Frame and Stator Assembly	1
31	37610	Rear Bearing	1
32	37612	Rotor Assembly	1
33	37613	Fixing Ring	1
34	37614	Fan	1
35	37615	Front Bearing	1
36	37616	Cover Stay Bolt	4
37	37617	M5X.8 X 10mm Long	12
38	37618	Protective Cover	2
39	32795	M10 X 35mm long HHCS	8

Wiring Diagram Rev – I

Diag #	Part #	Description	Qty
1	36769	Connector Mount	2
2	36771	Anderson Connector	2
3	36770	Connector Spacer	1
4	31086	30A Circuit Breaker	1
5	31085	20A Circuit Breaker	2
6	806343	Faceplate, Receptacle	1
7	306426	20A 120V Duplex Receptacle	2
8	306423	30A 120V Locking device Receptacle	1
9	802644	60A 120/240V Receptacle	1
10	31727	Voltmeter	1
11	31872	100A Breaker	1
12	306443	60A Breaker	1
13	36767	Faceplate, Breaker	1
14	36806	Faceplate Connector	1
15	777130	Breaker Mount Clip	4
16	31876	Breaker Mount Plate	1
W1	36863	Wire Assembly (W1)	1
W2	36861	Wire Assembly (W2)	1
W3	37264	Wire Assembly (W3)	1
W4-W6	32745	Wire Assembly (W4-W6)	1
G1	32744	Wire Assembly (G1)	1
G2	37265	Wire Assembly (G2)	1
G3, G4	31677	Wire Assembly (G3-G4)	1
G5	36862	Wire Assembly (G5)	1
B1	36856	Wire Assembly (B1)	1
B4	36855	Wire Assembly (B4)	1
B11	36859	Wire Assembly (B11)	1
B12	36865	Wire Assembly (B12)	1
B13	36857	Wire Assembly (B13)	1
B14	37266	Wire Assembly (B14)	1
B15	31891	Wire Assembly (B15)	1
B41	31893	Wire Assembly (B41)	1
B42	31864	Wire Assembly (B42)	1
B43	31895	Wire Assembly (B43)	1
B44	37267	Wire Assembly (B44)	1
B45	31897	Wire Assembly (B45)	1
B46	31898	Wire Assembly (B46)	1
B47-B49	31899	Wire Assembly (B47-B49)	1

Gearbox Exploded View

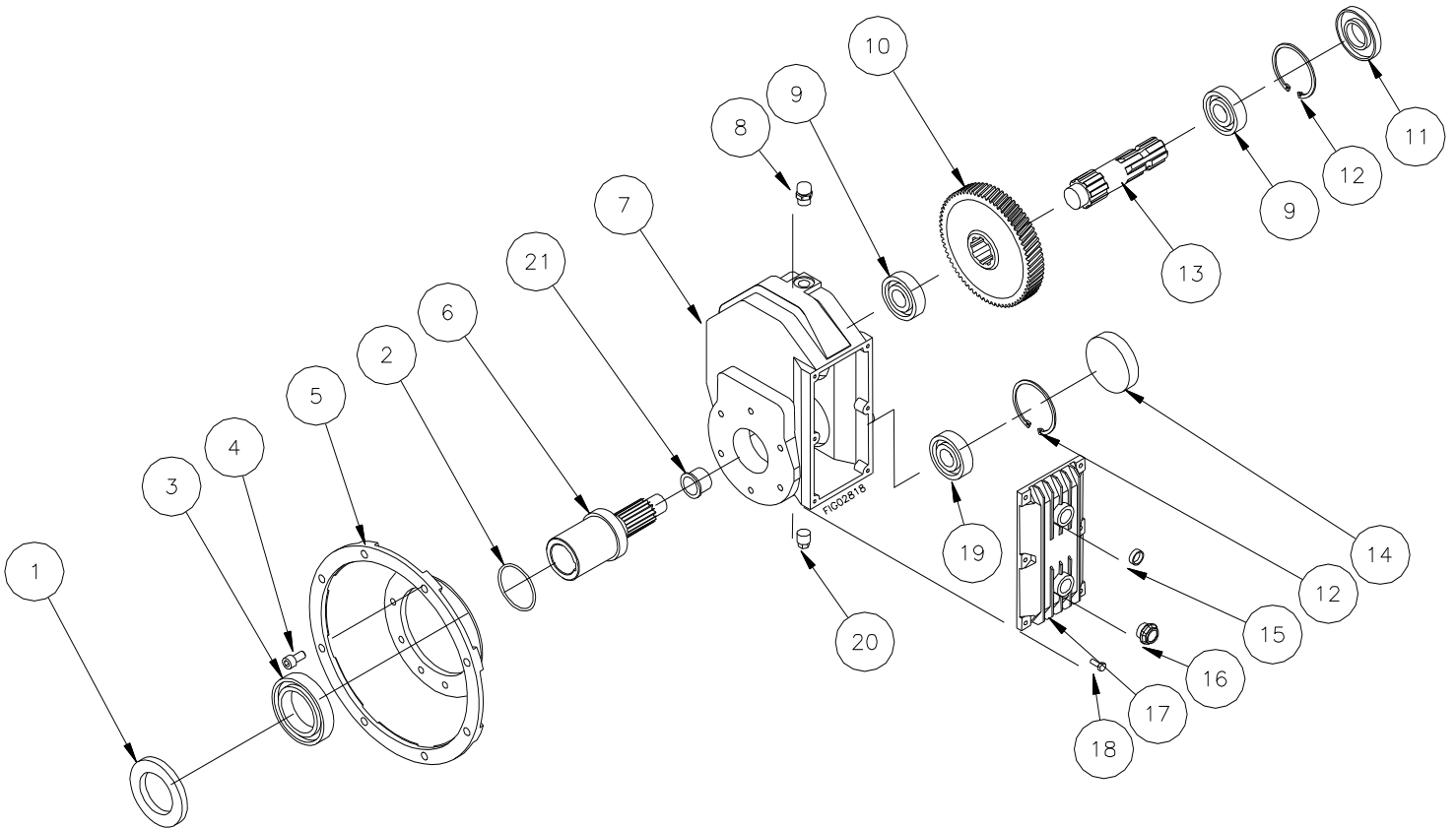

Diag #	Part #	Description	Qty
1	32989	Oil Seal	1
2	778694	Oil Seal	1
3	778695	Bearing 6012	1
4	32998	Bolt M10x20 UNI5931	6
5	778696	Flange	1
6	32993	Pinion	1
7	778697	Housing	1
8	32983	Breather Plug	1
9	778698	Bearing 6307	2
10	32987	Gear	1
11	32997	Oil Seal	1
12	32991	Snap Ring	2
13	32988	Shaft	1
14	32996	Oil Plug	1
15	32984	Oil Plug	1
16	32985	Oil Plug/ Sight Glass	1
17	32982	Cover	1
18	32999	Bolt M6x16 UNI5739	6
19	778699	Bearing 30208	1
20	33245	Oil Plug	1
21	778700	Sleeve	1

This page has intentionally been left blank.

Limited Warranty

Dear Valued Customer:

The NorthStar Product you just purchased is built with the finest material and craftsmanship. Use this product properly and enjoy the benefits from its high performance. By purchasing a NorthStar product, you show a desire for quality and durability. Like all mechanical equipment this unit requires a due amount of care. Treat this unit like the high quality piece of machinery it is. Neglect and improper handling may impair its performance. Please thoroughly read the instructions and understand the operation before using your product. Always contact NorthStar Product Support at 1-800-270-0810 prior to having any service or warranty work performed, as some services performed by parties other than NorthStar approved service centers may void this warranty. This warranty is in lieu of any other warranty expressed or implied and NorthStar assumes no other responsibility or liability outside that expressed within this warranty.

Limited Warranty

NorthStar shall warranty any piece of equipment manufactured, or parts of equipment manufactured, to be free from defects in material or workmanship for a period of:

NorthStar Warranty		
Item #	Consumer Warranty Period	Commercial Warranty Period
165937	2 years from date of purchase by user	2 years from date of purchase by user

“Consumer use” means personal residential household and/or recreational use by a consumer. “Commercial use” means all other uses, including use for commercial, income producing, primary power, off grid power, or rental purposes or when purchased by a business.

This warranty applies to the original purchaser of the equipment (verification of purchase, in the form of a receipt, is the responsibility of the buyer), is non-transferable, and covers parts and labor. Parts will be replaced or repaired at no charge, except when the equipment has failed due to lack of proper maintenance. If a part is no longer available, the part may be replaced with a similar part of equal function. Any misuse, abuse, alteration or improper installation or operations will void warranty. Determining whether a part is to be replaced or repaired is the sole decision of NorthStar. NorthStar will not provide for replacement of complete products due to defective parts. Any costs incurred due to replacement or repair of items outside of a NorthStar approved facility is the responsibility of the buyer and not covered under warranty. Transportation costs to and from service center is the responsibility of the customer.

This warranty specifically excludes the following; failure of parts due to damage caused by accident, fire, flood, windstorm, acts of God, applications not approved by NorthStar in writing, corrosion caused by chemicals, use of replacement parts which do not conform to manufacturer’s specifications, damage to accessory parts such as starting batteries, damage related to rodent and/or insect infestation and damage caused by vandalism. Additional exclusions: loss of running time, inconvenience, loss of income, or loss of use, including any implied warranty of merchantability of fitness for a specific use. Also, Outdoor Power Equipment needs periodic parts and service to perform well, and this warranty does not cover instances when normal use has exhausted the life of a component or the engine.

This warranty does not cover any personal injury or damage to surrounding property caused by failure of any part. Repair or replacement of parts does not extend the warranty period.

Please fill in the following information and have it on hand when you call in on a warranty claim.

Customer Number: _____

Date of Purchase: _____

NorthStar Serial Number: _____

Item Number: _____

▲ WARNING: This product can expose you to chemicals including gasoline engine exhaust, which is known to the State of California to cause cancer, and carbon monoxide, which is known to the State of California to cause birth defects or other reproductive harm.

For more information go to www.P65Warnings.ca.gov.



Manufactured by
Northern Tool + Equipment Co.,
2800 SouthCross Drive West
P.O. Box 1499 Burnsville, MN 55337-0499