

# Owner's Manual



## The **NOMAD**<sup>™</sup> Economy Welding Table

Part No. TS3020

### Contents:

- » Parts List
- » Assembly Instructions
- » Adjustments
- » Maintenance
- » Safety
- » Warranty



### Specifications:

Part No.	Tabletop Size	Table Height Range	Slots in Tabletop	Table Positions	Load Capacity	Weight
TS3020	30" W x 20" L <i>(760 x 510 mm)</i>	26" x 32" <i>(660 x 810 mm)</i>	1.1" <i>(28 mm)</i>	Horizontal, 30°, Folded	350 lbs. <i>(160 kg)</i>	44 lbs. <i>(20 kg)</i>

# Parts List

Part No. TS3020  
NOMAD™ Economy Welding Table

Item	Qty	Item	Qty		
A	Steel Table Top (30" x 20")	1	J	Caster Mounting Brackets	2
B	Table Leg Assembly with 4" tool shelf	1	K	Thermoplastic Star Knobs with 1-3/8" Threaded Shank	2
C1	30" Steel Guide Rail	1	L	Large Washers	2
C2	20" Steel Guide Rail	1	M1	6mm Lock Nuts	4
D	Height Adjustment Post & Angle Adjustment Plate Assemblies	2	M2	8mm Lock Nuts	10
E	Small Steel Clamp Levers with Washers	4	<b>Hex Head Screws</b>		
F	Crossbar	1	N1	M6 x 40mm (1.55")	4
G	Lock Pins with chains	2	N2	M8 x 20mm (0.78")	6
H	Casters	2	N3	M8 x 45mm (1.75")	2
			N4	M8 x 54mm (2.13")	2

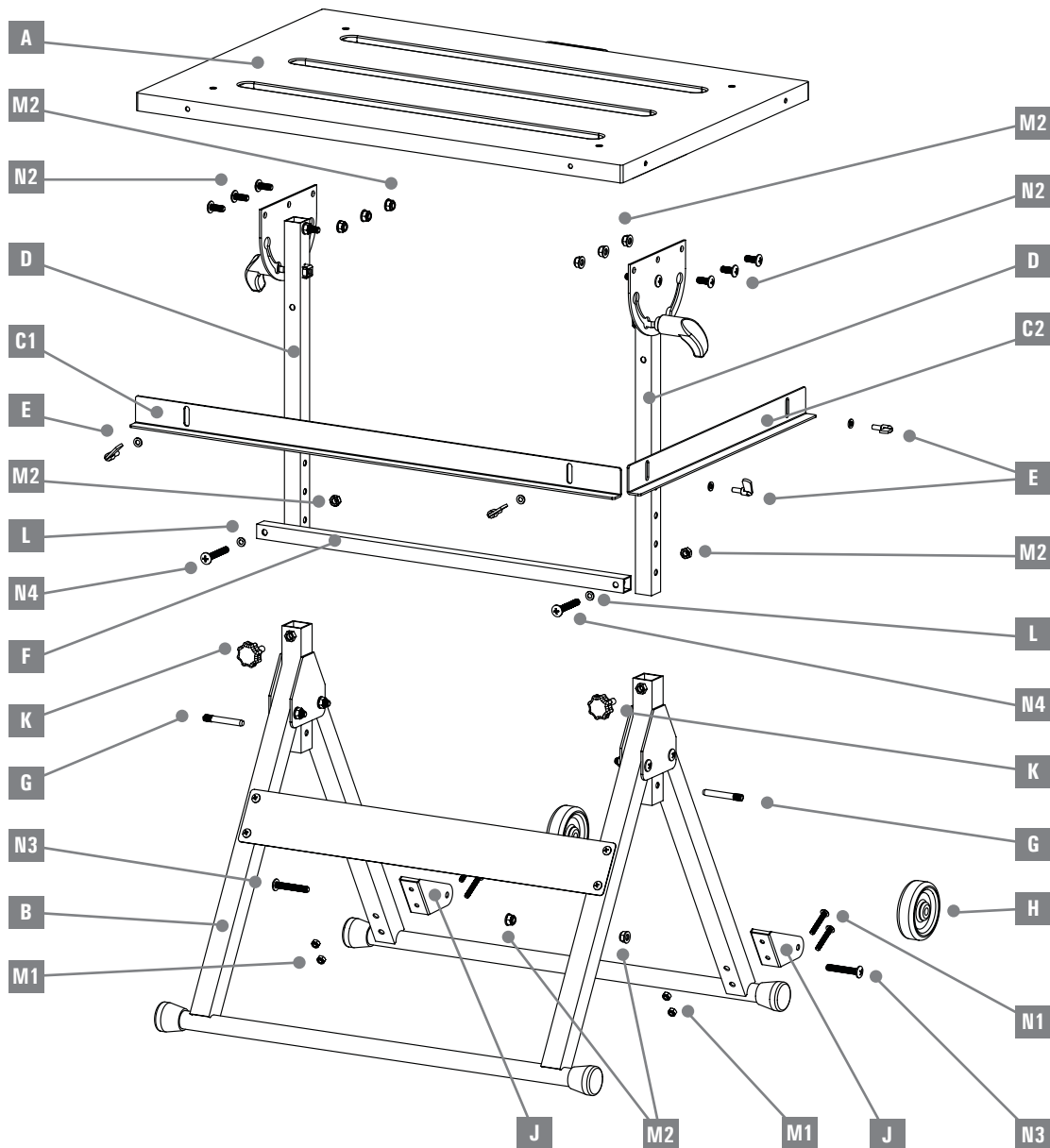

# Assembly Instructions

Part No. TS3020  
NOMAD™ Economy Welding Table

» Tools required for assembly : wrenches, phillips screwdriver and pliers.

## Setting up the Leg Assembly (Fig. 1-4)

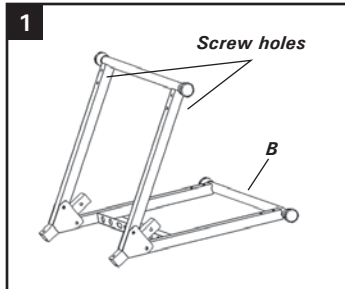

1. Place the leg assembly (**B**) flat on the work surface. The leg posts with screw holes should be facing up.
2. Slightly open the table legs by pulling the two crossbars in opposite directions.

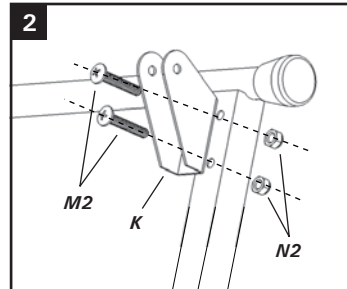

3. Attach caster mounting brackets (**J**) using two M6 x 40mm hex head screws (**N1**), and two 6mm lock nuts (**M1**).
4. Repeat on other side.

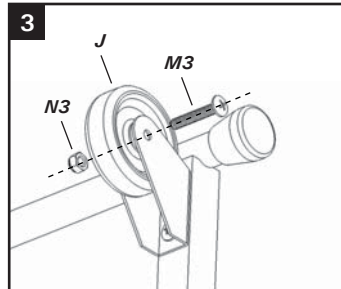

5. Mount casters (**H**) using two M8 x 45mm hex head screws (**N3**), and two 8mm lock nuts (**M2**).
6. Repeat on the other side.

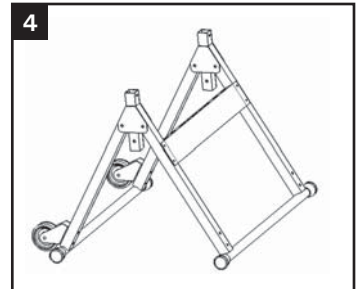

7. Fully open table leg assembly and place in the upright position.

## Setting up the Height Adjustment Post / Cross Bar Assembly (Fig. 5-8)

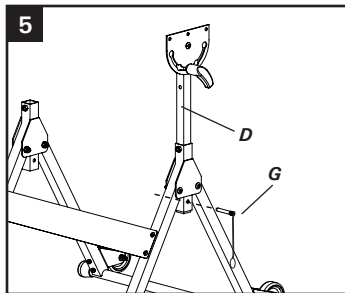

1. Place height adjustment post (**D**) into open table leg channel.
2. Place lock pin and chain assembly (**G**) into desired hole to "hold" height position.

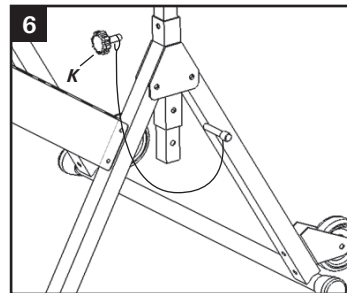

3. Attach thermoplastic star knob (**K**) to lock pin and chain assembly by placing the end ring on the chain around the shank of the knob.
4. Screw into post.

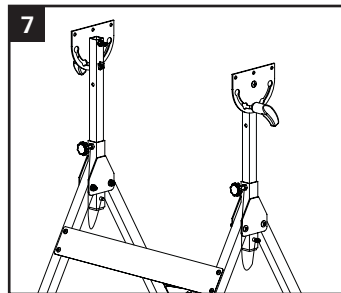

5. Repeat on the other side, make sure to match the height of the first side.
6. Tighten star knobs.

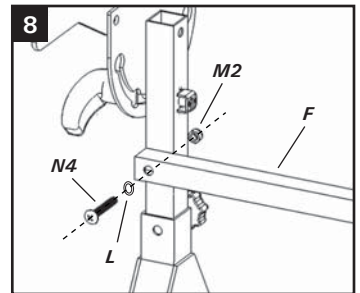

7. Install crossbar (**F**) using one M8 x 54mm hex head screw (**N4**), large washer (**L**), and 8mm lock nut (**M2**). Repeat on the other side.
8. Tighten crosslink bar screws.

## Installing Tabletop and Steel Guide Rails (Fig. 9-12)

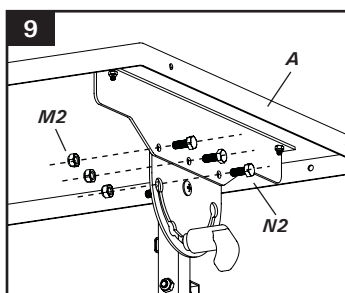

1. Install tabletop (**A**) to height adjustment post using three M8 x 20mm hex head screws (**N2**) and 8mm lock nuts (**M2**).

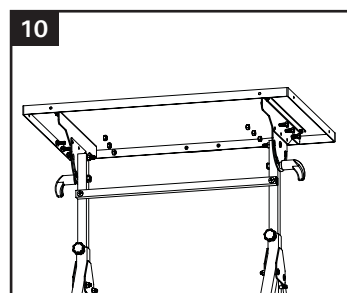

2. Repeat on the other side and tighten all screws.

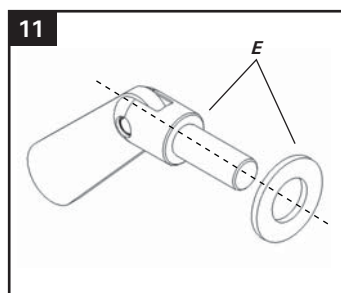

3. Locate the bag containing steel clamp levers and washers (**E**). Place four small washers on the shanks of the four small steel clamp levers.

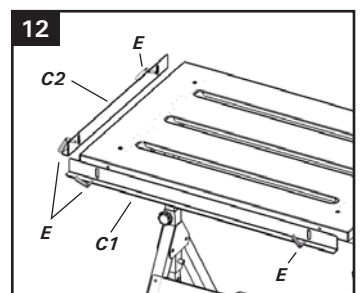

4. Attach the steel guide rails (**C1** & **C2**) to the table using the steel clamp levers.

# Adjustments

Part No. TS3020  
NOMAD™ Economy Welding Table

## Moving the Table

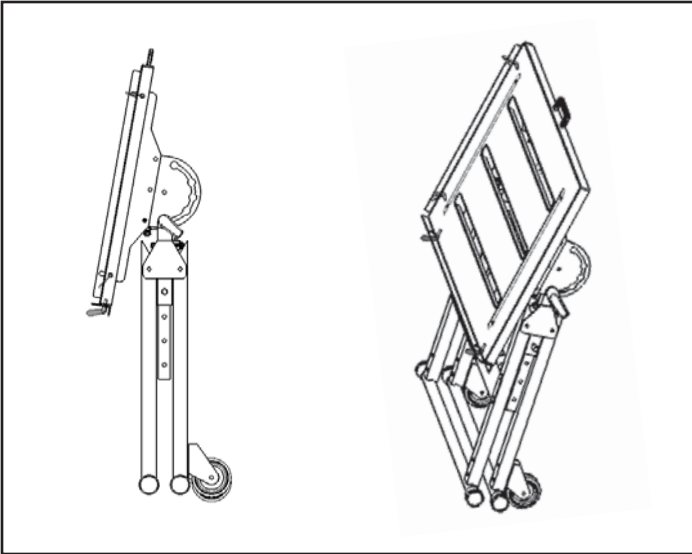

Loosen red levers. Fold tabletop down to completely vertical position. Push legs in to closed position. Lean the table back on the two casters, and use the pull handle to move the table.

## Adjusting the Table Height

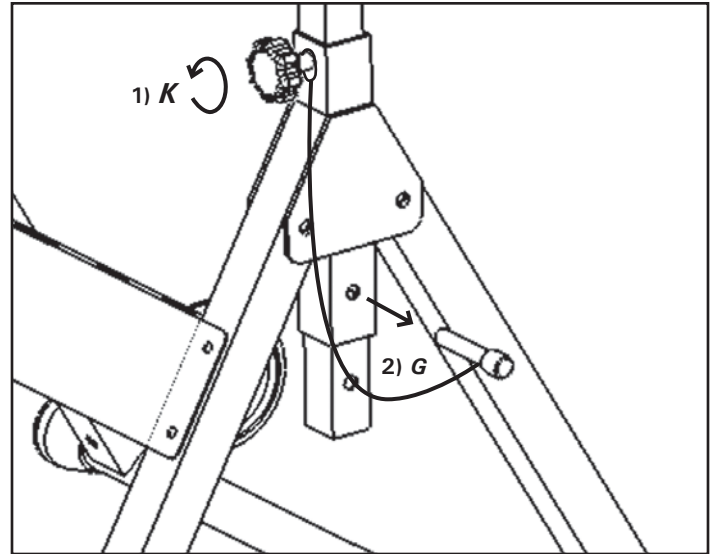

Loosen black knobs (*K*). Remove lock pins (*G*). Grasp tabletop and lift (evenly) to desired height. Re-insert lock pins and tighten knobs.

## Maintenance

Keep the table clean for optimal performance. Wipe away dust and debris from the tabletop and legs.

## Safety

ALWAYS wear safety goggles, gloves, and other appropriate safety items for protection. Use the table only for its intended purpose. NEVER stand on the table. Do not drop the table, throw it, or otherwise misuse the table.

## Limited 1 Year Warranty

Each STRONG HAND TOOL® product is warranted to be free from defects in material and workmanship. Return to place of purchase for a replacement if warranty applies.

**StrongHandTools™**  
Better Tools. Better Price.

7141 Paramount Blvd, Pico Rivera, CA 90660 | [www.stronghandtools.com](http://www.stronghandtools.com)  
Toll Free : 800.989.5244 | Tel : 562.949.8625 | [sales@stronghandtools.com](mailto:sales@stronghandtools.com)