

WHELEN[®]

ENGINEERING COMPANY INC.

Route 145, Winthrop Road,

Chester, Connecticut 06412

Phone: (860) 526-9504

Fax: (860) 526-4078

Internet: www.whelen.com

Sales e-mail: autosale@whelen.com

Canadian Sales e-mail: autocan@whelen.com

Customer Service e-mail: custserv@whelen.com

Installation Guide: LED Traffic Advisor™

Models: TANF85 / TANF85** / TAMF85

TACF85 / TACF85**

SCCF85

Automotive: Traffic Advisor

Safety First

This document provides all the necessary information to allow your Whelen product to be properly and safely installed. Before beginning the installation and/or operation of your new product, the installation technician and operator must read this manual completely. Important information is contained herein that could prevent serious injury or damage.

- **Proper installation of this product requires the installer to have a good understanding of automotive electronics, systems and procedures.**
- **If mounting this product requires drilling holes, the installer MUST be sure that no vehicle components or other vital parts could be damaged by the drilling process. Check both sides of the mounting surface before drilling begins. Also de-burr any holes and remove any metal shards or remnants. Install grommets into all wire passage holes.**
- **If this manual states that this product may be mounted with suction cups, magnets, tape or Velcro™, clean the mounting surface with a 50/50 mix of isopropyl alcohol and water and dry thoroughly.**
- **Do not install this product or route any wires in the deployment area of your air bag. Equipment mounted or located in the air bag deployment area will damage or reduce the effectiveness of the air bag, or become a projectile that could cause serious personal injury or death. Refer to your vehicle owners manual for the air bag deployment area. The User/Installer assumes full responsibility to determine proper mounting location, based on providing ultimate safety to all passengers inside the vehicle.**
- **For this product to operate at optimum efficiency, a good electrical connection to chassis ground must be made. The recommended procedure requires the product ground wire to be connected directly to the NEGATIVE (-) battery post.**
- **If this product uses a remote device to activate or control this product, make sure that this control is located in an area that allows both the vehicle and the control to be operated safely in any driving condition.**
- **Do not attempt to activate or control this device in a hazardous driving situation.**
- **This product contains either strobe light(s), halogen light(s), high-intensity LEDs or a combination of these lights. Do not stare directly into these lights. Momentary blindness and/or eye damage could result.**
- **Use only soap and water to clean the outer lens. Use of other chemicals could result in premature lens cracking (crazing) and discoloration. Lenses in this condition have significantly reduced effectiveness and should be replaced immediately. Inspect and operate this product regularly to confirm its proper operation and mounting condition. Do not use a pressure washer to clean this product.**
- **It is recommended that these instructions be stored in a safe place and referred to when performing maintenance and/or reinstallation of this product.**
- **FAILURE TO FOLLOW THESE SAFETY PRECAUTIONS AND INSTRUCTIONS COULD RESULT IN DAMAGE TO THE PRODUCT OR VEHICLE AND/OR SERIOUS INJURY TO YOU AND YOUR PASSENGERS!**

For warranty information regarding this product, visit www.whelen.com/warranty

Installation:

Note: When routing wires, it is very important that you choose a path that will keep the wires away from any excessive heat or any vehicle equipment that could compromise the integrity of the wires (ex. trunk lids, door jams, etc.).

Note: Permanent mounting of this product will require drilling. It is absolutely necessary to make sure that no other vehicle components could be damaged by this process. Check both sides of the mounting surface before starting. If damage is likely, select a different mounting location.

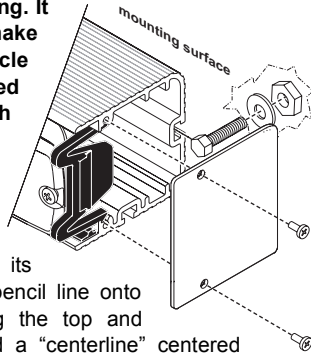
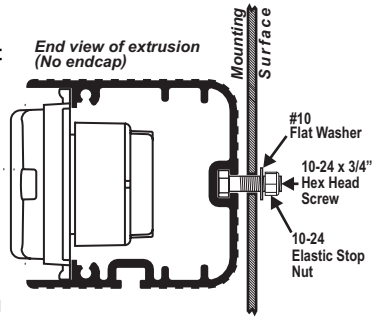

1. Position the unit onto its mounting location. Draw a pencil line onto the mounting surface along the top and bottom of the extrusion and a "centerline" centered between the two.
2. Four 13/64" holes are required to mount this unit. These holes may be located anywhere along the horizontal centerline that you drew in step one. It's best to locate the holes as far apart as possible. Mark the hole location onto the mounting surface.
3. Using a #9 drill bit, drill a hole in each of the hole locations marked.
4. Remove the endcap and slide the two hex-head mounting bolts (included) into the channel provided at the rear of the extrusion and reinstall the endcap.
5. Align these bolts with the 4 mounting holes and insert them into the mounting holes.
6. Install a flat washer and elastic stop nut onto each bolt and tighten.

Wiring:

WARNING: All customer supplied wires that connect to the positive terminal of the battery must be sized to supply at least 125% of the maximum operating current and **FUSED** at the battery to carry that load. **DO NOT USE CIRCUIT BREAKERS WITH THIS PRODUCT!**

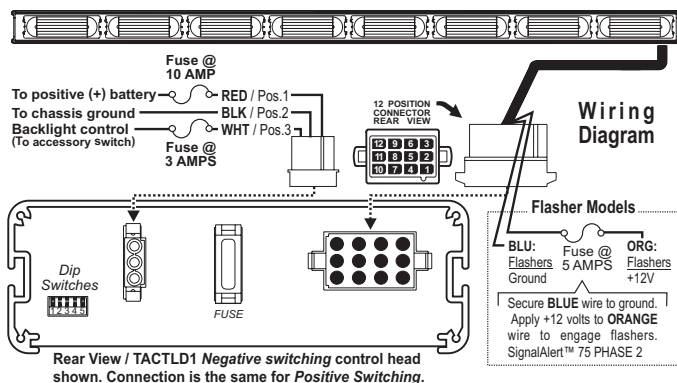

Operation:

Connect the Traffic Advisor™ to your control head as shown in the wiring diagram above and follow the instructions included with the control head for operation.

Control Cable Identification

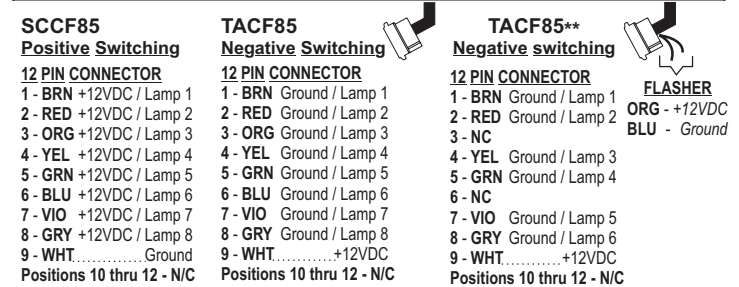
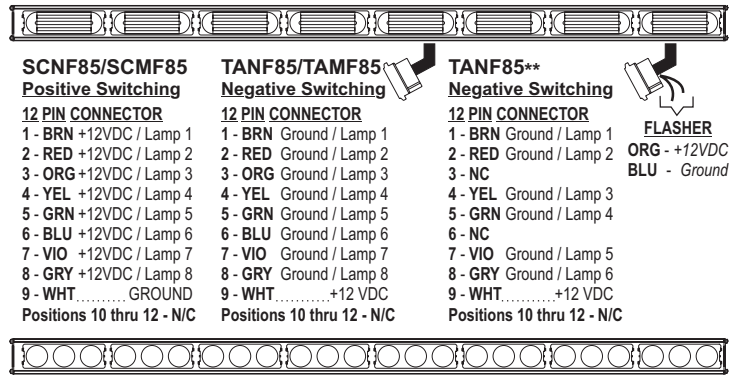

Service:

This section shows you how to access the lightbar for service or lighthead replacement. To replace a lighthead, first loosen the set screw(s) on the bracket. Now squeeze the clip together so that it disengages from the extrusion and pull the bracket straight out. With the bracket removed the lighthead lifts out and can be unplugged from the harness and removed from the lightbar.

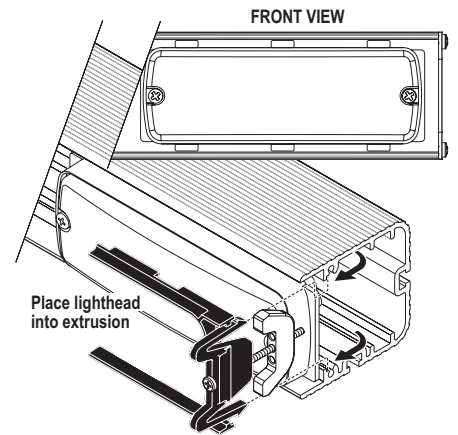

IMPORTANT! It is the responsibility of the installation technician to make sure that the installation and operation of this product will not interfere with or compromise the operation or efficiency of any vehicle equipment!

IMPORTANT! Before returning this vehicle to active service, visually confirm the proper operation of this product, as well as all vehicle components/equipment.

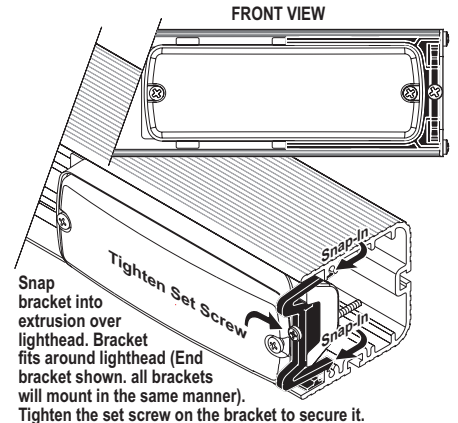

IMPORTANT WARNING!
CAUTION! DO NOT LOOK DIRECTLY AT THESE LED'S WHILE THEY ARE ON. MOMENTARY BLINDNESS AND/OR EYE DAMAGE COULD RESULT!

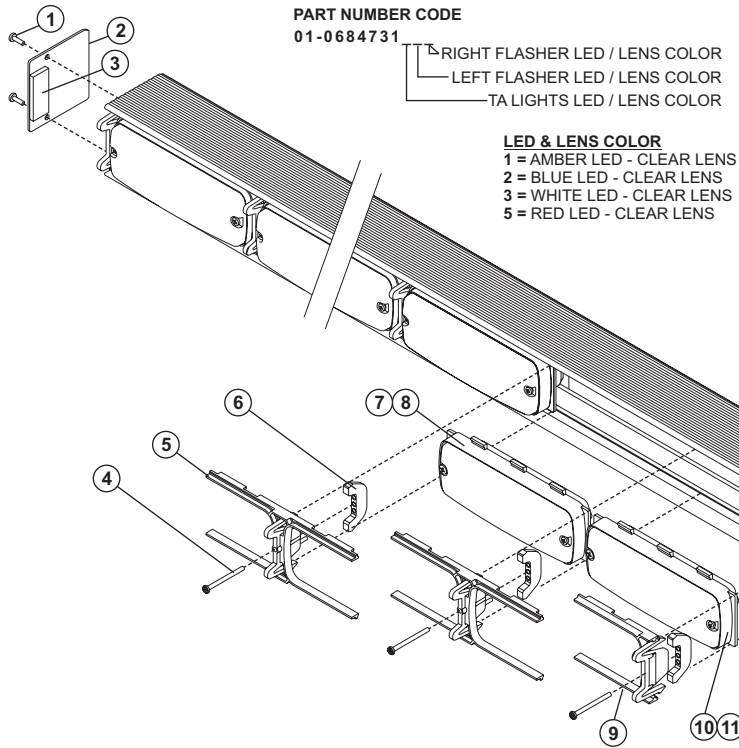

QTY	ITEM	PART NUMBER	DESCRIPTION
*		01-0684731	TA ASS'Y, 500 LIN LED SNAP-IN (TANF85_)
4	1	14-062219-06D	SCREW / #6-32 X 3/8 PPHMS ROLOK ZN
1	2	11-243415-007	ENDCAP / EXT. MT. 500 SNAP-IN
2	3	38-0143142-00	GASKET / ENDCAP/LIGHTHEAD .25"
9	4	15-04521B-220	SCREW / 4 x 1-3/8 PPH PLASTI-LOK
7	5	07-264851-000	BRACKET / EXT. MT. 500 SNAP-IN
9	6	19-343555-000	CLAMP NUT / DIVIDER
A/R	7	01-066A009211	ASSY / LHEAD 500 LIN LED STDY AMBER
A/R	8	01-066A009251	ASSY / LHEAD 500 LIN LED STDY RED
2	9	07-264851-001	BRACKET / EXT. MT. 500 SNAP-IN / HALF
A/R	10	01-0664633113	ASSY / LHEAD 500 LIN LED SYNC AMBER
AR	11	01-0664633123	ASSY / LHEAD 500 LIN LED SYNC BLUE
AR	12	01-0664633133	ASSY / LHEAD 500 LIN LED SYNC WHITE
A/R	13	01-0664633153	ASSY / LHEAD 500 LIN LED SYNC RED
A/R	14	01-0664633143	ASSY / LHEAD 500 LIN LED SYNC GREEN
1	15	11-36A055-045	EXTRUSION / TA 500 LED SNAP-IN
1	16	46-076A059-00	HARNESS ASSY / TA FLASHERS 500 LIN
1	17	46-076A060-00	HARNESS ASSY / TA LIGHTS 500 LIN
1	18	11-243415-017	ENDCAP / EXT. MT. 500 with HOLE
1	19	21-11121602-0	3/8" GROMMET / ID x 1/2" OD
1	20	46-076A061-20	CABLE ASSEMBLY / INPUT
1	21	39-0412014-14	HOUSING / PIN 12 POS AMP

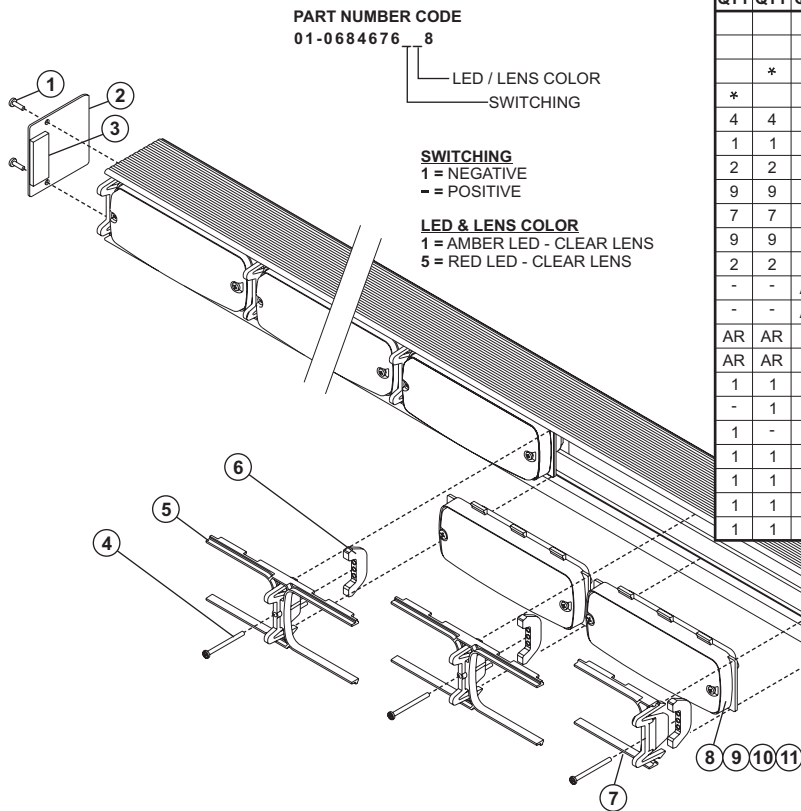

QTY	QTY	QTY	QTY	ITEM	PART NUMBER	DESCRIPTION
		*			01-0684676_8	TA, 500 LIN LED, POS. SWITCHING (SCNF85)
		*			01-06846761_8	TA, 500 LIN LED, NEG. SWITCHING (TANF85)
	*				01-0686014_8	TA, 500 TIR6 LED, POS. SWITCHING (SCMF85)
	*				01-06860141_8	TA, 500 TIR6 LED, NEG. SWITCHING (TAMF85)
4	4	4	4	1	14-062219-06D	SCREW / #6-32 X 3/8 PPHMS ROLOK ZN
1	1	1	1	2	11-243415-007	ENDCAP / EXT. MT. 500 SNAP-IN
2	2	2	2	3	38-0143142-00	GASKET / ENDCAP/LIGHTHEAD .25"
9	9	9	9	4	15-04521B-220	SCREW / #4 X 1 3/8 PPH PLASTI-LOK
7	7	7	7	5	07-264851-000	BRACKET / EXT. MT. 500 SNAP-IN
9	9	9	9	6	19-343555-000	CLAMP NUT / DIVIDER
2	2	2	2	7	07-264851-001	BRACKET / EXT. MT. 500 SNAP-IN-HALF
-	-	AR	AR	8	01-066A009211	ASSY / LHEAD 500 LIN LED STDY AMBER
-	-	AR	AR	9	01-066A009251	ASSY / LHEAD 500 LIN LED STDY RED
AR	AR	-	-	10	01-0663507137	LIGHTHEAD, 500 TIR6 LED STDY (AMBER)
AR	AR	-	-	11	01-0663507537	LIGHTHEAD, 500 TIR6 LED STDY (RED)
1	1	1	1	12	11-36A055-045	EXTRUSION / TA 500 LED SNAP-IN
-	1	-	1	13	46-076A041-00	HARNESS ASSY / TA500 LIN LED
1	-	1	-	14	46-076A082-00	HARNESS ASSY / TA500 LIN LED
1	1	1	1	15	11-243415-017	ENDCAP / EXT. MT. 500 W/HOLE
1	1	1	1	16	21-11121602-0	GROMMET 3/8" ID x 1/2" HOLE
1	1	1	1	17	46-076A042-20	CABLE ASSEMBLY / INPUT
1	1	1	1	18	39-0412014-14	HOUSING / PIN 12 POS AMP

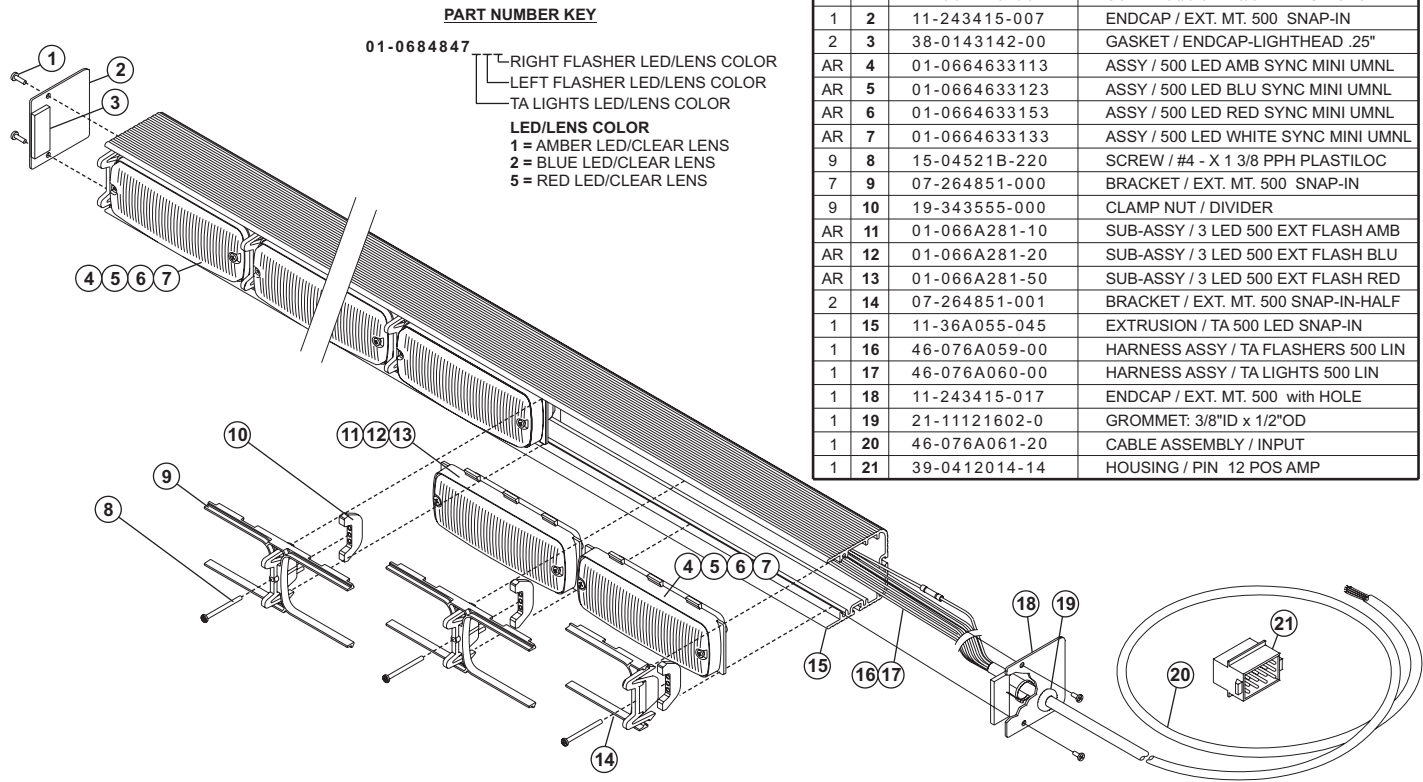

PART NUMBER KEY
 01-0684847
 — RIGHT FLASHER LED/LENS COLOR
 — LEFT FLASHER LED/LENS COLOR
 — TA LIGHTS LED/LENS COLOR
LED/LENS COLOR
 1 = AMBER LED/CLEAR LENS
 2 = BLUE LED/CLEAR LENS
 5 = RED LED/CLEAR LENS

QTY	ITEM	PART NUMBER	DESCRIPTION
*		01-0684847	TA ASSY, 500 LED SNAP-IN (TACF85_)
4	1	14-062219-06D	SCREW / #6-32 X 3/8 PPHMS ROLOK ZN
1	2	11-243415-007	ENDCAP / EXT. MT. 500 SNAP-IN
2	3	38-0143142-00	GASKET / ENDCAP-LIGHTHEAD .25"
AR	4	01-0664633113	ASSY / 500 LED AMB SYNC MINI UMNL
AR	5	01-0664633123	ASSY / 500 LED BLU SYNC MINI UMNL
AR	6	01-0664633153	ASSY / 500 LED RED SYNC MINI UMNL
AR	7	01-0664633133	ASSY / 500 LED WHITE SYNC MINI UMNL
9	8	15-04521B-220	SCREW / #4 - X 1 3/8 PPH PLASTILOK
7	9	07-264851-000	BRACKET / EXT. MT. 500 SNAP-IN
9	10	19-343555-000	CLAMP NUT / DIVIDER
AR	11	01-066A281-10	SUB-ASSY / 3 LED 500 EXT FLASH AMB
AR	12	01-066A281-20	SUB-ASSY / 3 LED 500 EXT FLASH BLU
AR	13	01-066A281-50	SUB-ASSY / 3 LED 500 EXT FLASH RED
2	14	07-264851-001	BRACKET / EXT. MT. 500 SNAP-IN-HALF
1	15	11-36A055-045	EXTRUSION / TA 500 LED SNAP-IN
1	16	46-076A059-00	HARNESS ASSY / TA FLASHERS 500 LIN
1	17	46-076A060-00	HARNESS ASSY / TA LIGHTS 500 LIN
1	18	11-243415-017	ENDCAP / EXT. MT. 500 with HOLE
1	19	21-11121602-0	GROMMET: 3/8"ID x 1/2"OD
1	20	46-076A061-20	CABLE ASSEMBLY / INPUT
1	21	39-0412014-14	HOUSING / PIN 12 POS AMP

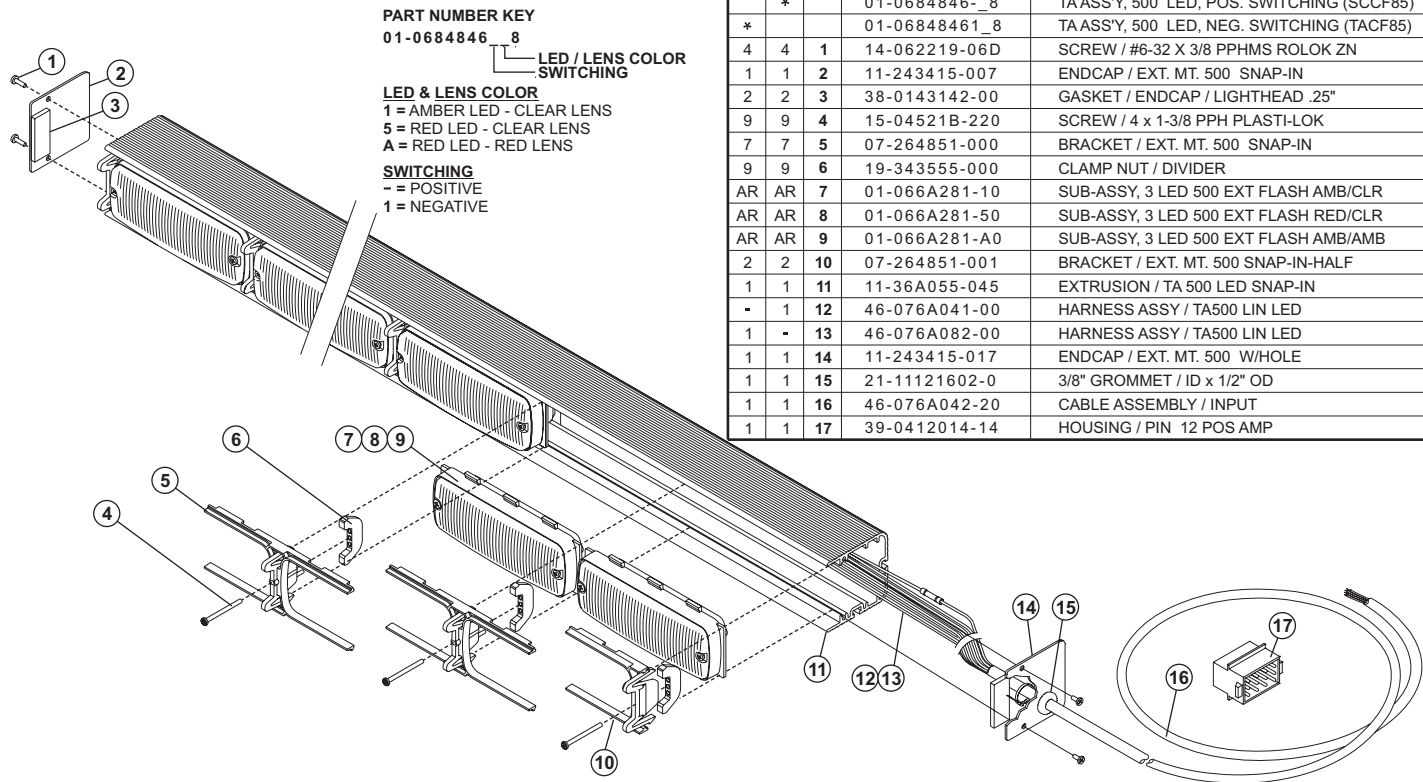

PART NUMBER KEY
 01-0684846
 — LED / LENS COLOR
 — SWITCHING
LED & LENS COLOR
 1 = AMBER LED - CLEAR LENS
 5 = RED LED - CLEAR LENS
 A = RED LED - RED LENS
SWITCHING
 - = POSITIVE
 1 = NEGATIVE

QTY	QTY	ITEM	PART NUMBER	DESCRIPTION
*			01-0684846-8	TA ASSY, 500 LED, POS. SWITCHING (SCCF85)
*			01-06848461-8	TA ASSY, 500 LED, NEG. SWITCHING (TACF85)
4	4	1	14-062219-06D	SCREW / #6-32 X 3/8 PPHMS ROLOK ZN
1	1	2	11-243415-007	ENDCAP / EXT. MT. 500 SNAP-IN
2	2	3	38-0143142-00	GASKET / ENDCAP / LIGHTHEAD .25"
9	9	4	15-04521B-220	SCREW / 4 x 1-3/8 PPH PLASTI-LOK
7	7	5	07-264851-000	BRACKET / EXT. MT. 500 SNAP-IN
9	9	6	19-343555-000	CLAMP NUT / DIVIDER
AR	AR	7	01-066A281-10	SUB-ASSY, 3 LED 500 EXT FLASH AMB/CLR
AR	AR	8	01-066A281-50	SUB-ASSY, 3 LED 500 EXT FLASH RED/CLR
AR	AR	9	01-066A281-A0	SUB-ASSY, 3 LED 500 EXT FLASH AMB/AMB
2	2	10	07-264851-001	BRACKET / EXT. MT. 500 SNAP-IN-HALF
1	1	11	11-36A055-045	EXTRUSION / TA 500 LED SNAP-IN
-	1	12	46-076A041-00	HARNESS ASSY / TA500 LIN LED
1	-	13	46-076A082-00	HARNESS ASSY / TA500 LIN LED
1	1	14	11-243415-017	ENDCAP / EXT. MT. 500 W/HOLE
1	1	15	21-11121602-0	3/8" GROMMET / ID x 1/2" OD
1	1	16	46-076A042-20	CABLE ASSEMBLY / INPUT
1	1	17	39-0412014-14	HOUSING / PIN 12 POS AMP