

# WHELEN<sup>®</sup>

ENGINEERING COMPANY INC.

Route 145, Winthrop Road,  
Chester, Connecticut 06412

Phone: (860) 526-9504

Fax: (860) 526-4078

Internet: [www.whelen.com](http://www.whelen.com)

Sales e-mail: [autosale@whelen.com](mailto:autosale@whelen.com)

Canadian Sales e-mail: [autocan@whelen.com](mailto:autocan@whelen.com)

Customer Service e-mail: [custserv@whelen.com](mailto:custserv@whelen.com)

## Installation Guide: Justice™ Competitor Series Lightbar

### Safety First

This document provides all the necessary information to allow your Whelen product to be properly and safely installed. Before beginning the installation and/or operation of your new product, the installation technician and operator must read this manual completely. Important information is contained herein that could prevent serious injury or damage.

- Proper installation of this product requires the installer to have a good understanding of automotive electronics, systems and procedures.
- If mounting this product requires drilling holes, the installer **MUST** be sure that no vehicle components or other vital parts could be damaged by the drilling process. Check both sides of the mounting surface before drilling begins. Also de-burr any holes and remove any metal shards or remnants. Install grommets into all wire passage holes.
- If this manual states that this product may be mounted with suction cups, magnets, tape or Velcro™, clean the mounting surface with a 50/50 mix of isopropyl alcohol and water and dry thoroughly.
- Do not install this product or route any wires in the deployment area of your air bag. Equipment mounted or located in the air bag deployment area will damage or reduce the effectiveness of the air bag, or become a projectile that could cause serious personal injury or death. Refer to your vehicle owners manual for the air bag deployment area. The User/Installer assumes full responsibility to determine proper mounting location, based on providing ultimate safety to all passengers inside the vehicle.
- For this product to operate at optimum efficiency, a good electrical connection to chassis ground must be made. The recommended procedure requires the product ground wire to be connected directly to the **NEGATIVE (-)** battery post.
- If this product uses a remote device to activate or control this product, make sure that this control is located in an area that allows both the vehicle and the control to be operated safely in any driving condition.
- Do not attempt to activate or control this device in a hazardous driving situation.
- This product contains either strobe light(s), halogen light(s), high-intensity LEDs or a combination of these lights. Do not stare directly into these lights. Momentary blindness and/or eye damage could result.
- Use only soap and water to clean the outer lens. Use of other chemicals could result in premature lens cracking (crazing) and discoloration. Lenses in this condition have significantly reduced effectiveness and should be replaced immediately. Inspect and operate this product regularly to confirm its proper operation and mounting condition. Do not use a pressure washer to clean this product.
- It is recommended that these instructions be stored in a safe place and referred to when performing maintenance and/or reinstallation of this product.
- **FAILURE TO FOLLOW THESE SAFETY PRECAUTIONS AND INSTRUCTIONS COULD RESULT IN DAMAGE TO THE PRODUCT OR VEHICLE AND/OR SERIOUS INJURY TO YOU AND YOUR PASSENGERS!**

**For warranty information regarding this product, visit [www.whelen.com/warranty](http://www.whelen.com/warranty)**

## Permanent Mounting:

1. Locate the mounting foot and mounting plate included with your lightbar. If not already present, install the mounting plate onto the mounting foot. When properly positioned, this plate is centered from side to side on the mounting foot.
2. Flip lightbar upside-down to expose bottom of extrusion and place mounting foot onto extrusion.
3. Rotate the mounting foot 90° in a counter-clockwise direction. Make sure that the edges of the mounting foot swing into position under the extrusion mounting lip.
4. Repeat this procedure for the remaining mounting foot and return the lightbar to its right side-up position.
5. Position the lightbar onto the vehicle roof in the desired mounting location. One often selected location is directly above the B-pillars. This area is the strongest part of the roof. Refer to your lightbar manual for your lightbars cable exit location, to be sure that the lightbar is facing the proper direction.
6. Adjust the two mounting feet outwards so that they are as close to the edge of the roof as possible. Make sure that both mounting feet are in full contact with the roof (See below). Be sure that there is no less than 1/2" clearance between the roof and the lightbar at their closest point. When the mounting feet are in their proper position, lightly tighten the mounting foot allen head set screws.
7. Turn the lightbar upside down and firmly tighten all of the set screws from step 6 (2 or 4 per side).
8. On the mounting foot, remove either the two outer or inner rubber mounting pads. Carefully remove the mounting pad's guide dart so the hole through the center of the pad is exposed then replace the pad (Standard foot only). On the adjustable foot, use the hole in the pad as a guide to drill the two holes into the mounting foot.
9. Place the lightbar in its final mounting position on the vehicle, mark the mounting hole locations off onto the mounting surface, remove the lightbar and drill the mounting holes.
10. Place the lightbar back onto the vehicle lined up with the mounting holes and secure the mounting feet to the vehicle using the supplied hardware.

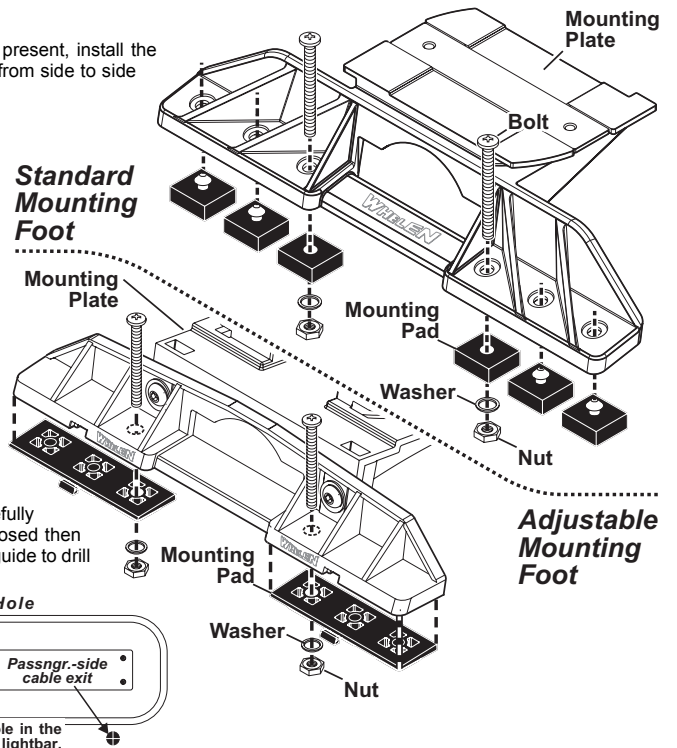

**IMPORTANT:** For strap mounting, be sure you have the right sized lightbar for your vehicle. The bar should be approximately the same width as the vehicle roof. If too large or small it will not mount properly and may come loose during driving.

**NOTE:** Unless otherwise specified, the lightbar mounting feet must be sitting as close to the edge of the roof as possible. They must also be in full contact with the roof and not be hanging off the edge.

## Slide Bolt Mounting (Permanent):

This lightbar mounts with 4 bolts affixed to mounting plates that slide into the track on the bottom of the lightbar base. Figures 1 and 1a show how the slide bolt assembly slides into your lightbars base and mounts onto the vehicle. Use an appropriately sized drill bit sized for a 1/2 - #13 X 2" bolt, to drill the mounting holes.

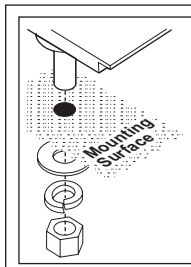

### Slide Bolt Mounting:

1. Remove one lightbar endcap.
2. Insert slide bolts into base, slide them across to their mounting position and secure them with the set screws
3. Position the lightbar onto the vehicle and mark the four bolt hole locations on the mounting surface
4. Drill the four holes with an appropriately sized drill bit
5. Replace end cap. Insert bolts into their 4 mounting holes. Secure the lightbar with the supplied hardware

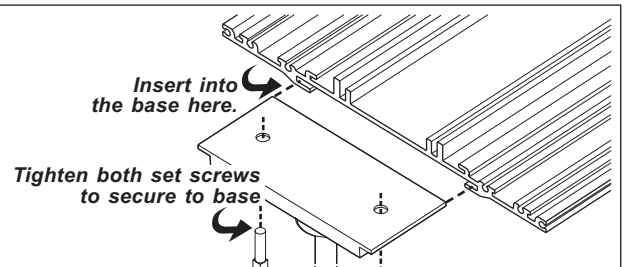

## Strap Mounting:

1. Locate the mounting foot, mounting plate and tinnerman plate included with your lightbar. If not already present, install the mounting plate onto the mounting foot. When properly positioned, this plate is centered from side to side on the mounting foot.
2. Flip the lightbar upside-down to expose the bottom of the extrusion and place the mounting foot onto the extrusion.
3. Rotate the mounting foot 90° in a counter-clockwise direction. Make sure that the edges of the mounting foot swing into position under the extrusion mounting lip. Install a tinnerman plate onto

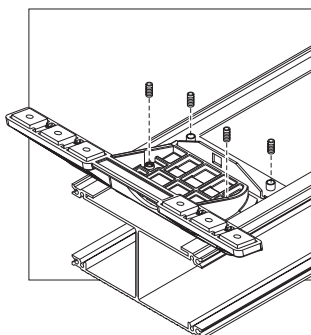
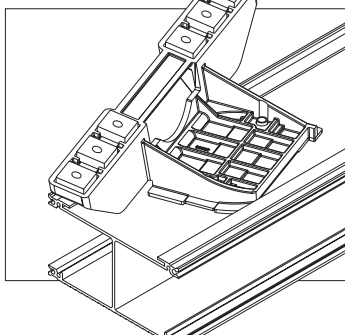
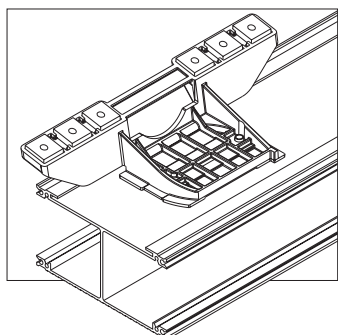

4. Repeat this procedure for the remaining mounting foot and tinnerman plate and return the lightbar to its right side-up position.
5. Position the lightbar onto the vehicle roof in the desired mounting location. One often selected location is directly above the B-pillars. This area is the strongest part of the roof. Refer to your lightbar manual for cable exit location, to be sure that the lightbar is facing the proper direction.
6. Adjust the two mounting feet outwards so that they are as close to the edge of the roof as possible. Both mounting feet must be in full contact with the roof. Be sure that there is no less than 1/2" clearance between the roof and the lightbar at their closest point. When the mounting feet are in their proper position, lightly tighten the mounting foot allen head set screws.

7. Return the lightbar to an upside down position. Slide each tinnerman plate outwards until it is fully engaged with its corresponding mounting foot. With the mounting feet and tinnerman plates in their proper positions firmly tighten all of the set screws (2 or 4 per side). Flip the lightbar right side-up and return it to its mounting position.

- Open both drivers side doors. In the area directly below the mounting foot, carefully pull the drivers side weather-strip away from the vehicle. Remove enough so that the area where the mounting strap will be secured to the vehicle is exposed. Repeat procedure for passenger side.
- Insert the mounting strap through the mounting foot. Be sure that the strap fits flush against the area where it will be secured onto the vehicle. Insert the tension bolt through the mounting strap and into the tinnerman nut on the tinnerman plate. Tighten slightly with a long shafted, Phillips screwdriver. Repeat procedure for passenger side.

- If your mounting strap has mounting holes in the end of the strap, use these holes as a template to drill appropriately sized pilot holes through the strap and into the vehicle. Repeat for passenger side of the vehicle.
- Firmly tighten the tension bolts to secure the lightbar to the vehicle.

**NOTE: Model MKAJ is an adjustable mounting foot. On this model you may loosen the screws on the rear of the foot and adjust the angle of the lightbar. This feature can be used if the angle of the roof is not level with the road.**

**IMPORTANT: To adjust the leveling screws you must use a torque wrench set at 35 to 40 ft. lbs.**

### Standard Mounting Foot / Model MKEZ

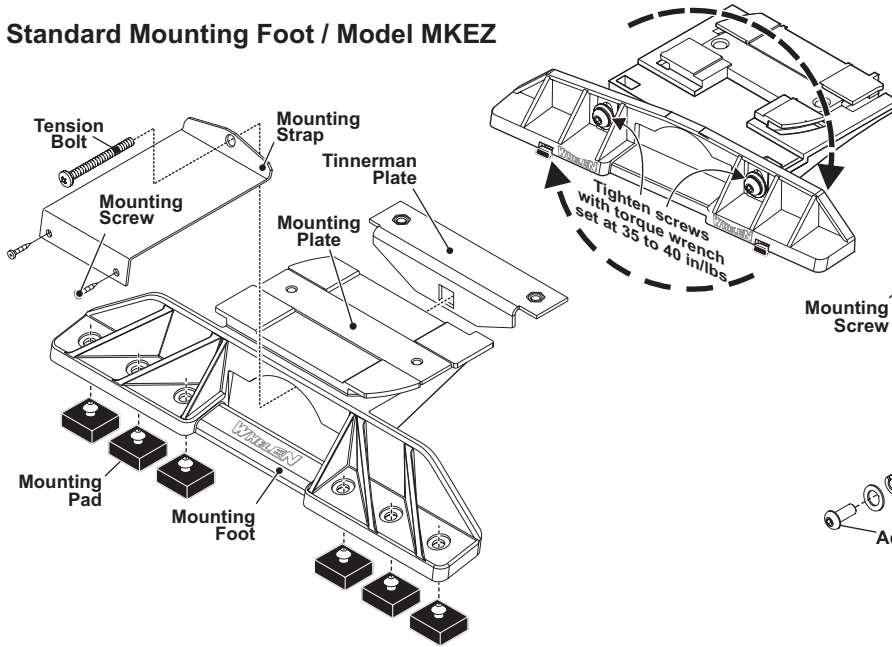

### Adjustable Mounting Foot / Model MKAJ

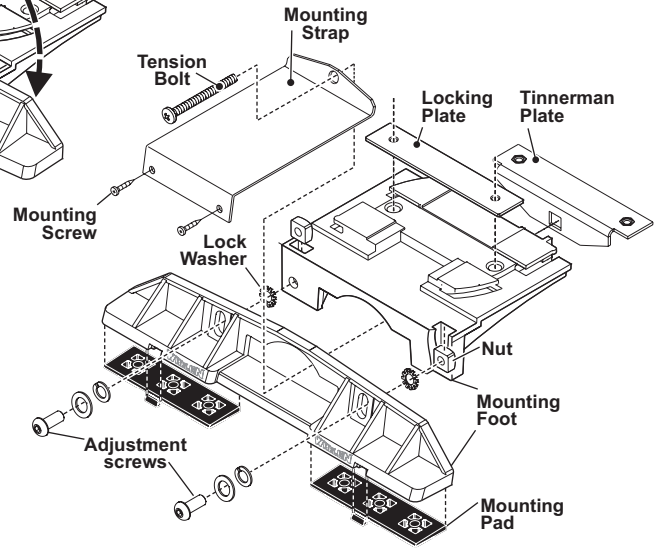

### 5" Mounting Foot

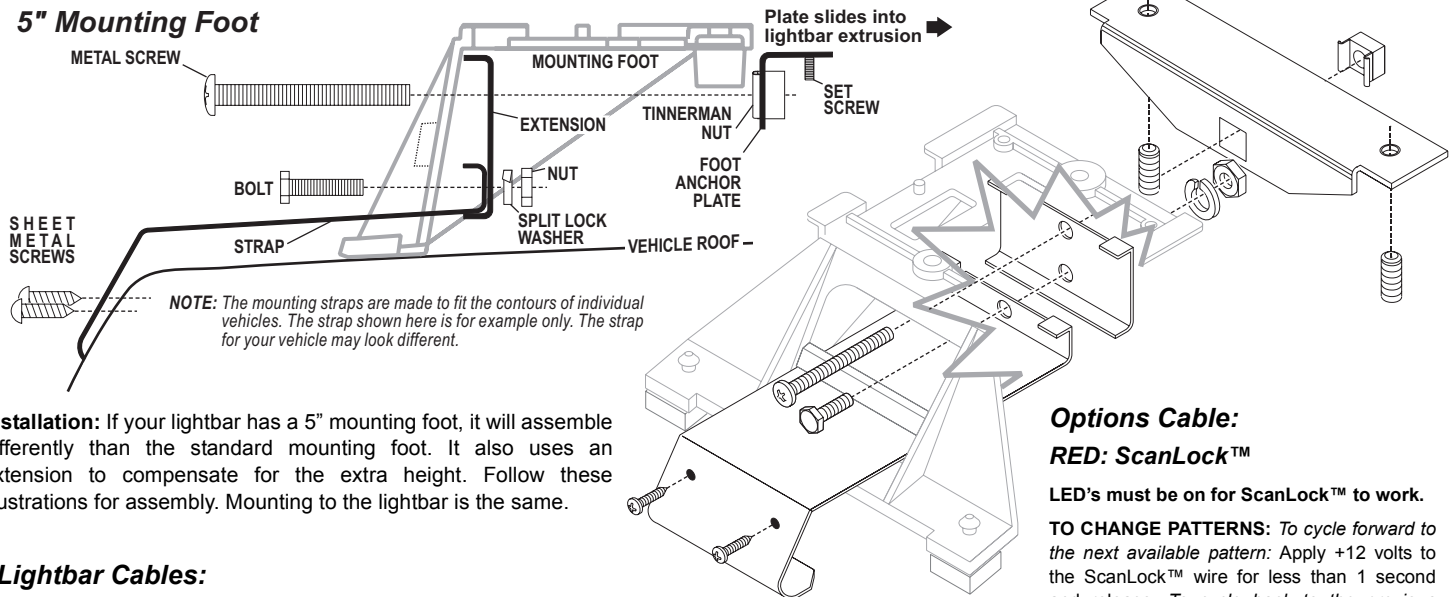

**Installation:** If your lightbar has a 5" mounting foot, it will assemble differently than the standard mounting foot. It also uses an extension to compensate for the extra height. Follow these illustrations for assembly. Mounting to the lightbar is the same.

### Lightbar Cables:

**Standard Lightbar:** This lightbar uses a 4 conductor cable for LED's, a 6 conductor cable for Halogen and a 3 conductor cable for Options. There is also an option for Brake-Tail to connect to your brake lights. Extend the 3, 4 and 6 conductor cables towards your switch panel. The instructions included with your switches will provide switch wiring information. The optional brake-tail cable connects to the brake lights.

Refer to the next page for wire designations and fusing.

**WARNING! All Customer supplied wires that connect to the positive terminal of the battery must be sized to supply at least 125% of the maximum operating current and FUSED at the battery to carry that load. DO NOT USE CIRCUIT BREAKERS WITH THIS PRODUCT!**

### Halogen Cable:

- WHITE:** Apply +12 volts to activate the TakeDowns or Worklight
- GREEN:** Apply +12 volts to activate the Passenger Side Alley lights
- RED:** Apply +12 volts to activate the Driver Side Alley light.
- BLUE:** Apply +12 volts to activate the Takedowns in flashing mode.

### Options Cable:

**RED: ScanLock™**

LED's must be on for ScanLock™ to work.

**TO CHANGE PATTERNS:** To cycle forward to the next available pattern: Apply +12 volts to the ScanLock™ wire for less than 1 second and release. To cycle back to the previous pattern: Apply +12 volts to the ScanLock™ wire for more than 1 second and release.

**TO CHANGE THE DEFAULT PATTERN:** When the desired pattern is active, allow it to run for more than 5 seconds. The lighthouse will now display this pattern when activated.

**TO RESTORE THE FACTORY DEFAULT PATTERN:** With power to the lighthoods off, apply +12 volts to the ScanLock™ wire. While still applying +12 volts to the ScanLock™ wire, turn power to the lighthoods back on. The factory default pattern should now be displayed.

A Normally Open momentary switch can be used to control ScanLock™ operation.

### IMPORTANT WARNING!

**CAUTION! DO NOT LOOK DIRECTLY AT THESE LED'S WHILE THEY ARE ON. MOMENTARY BLINDNESS AND/OR EYE DAMAGE COULD RESULT!**

**Available Flash Patterns:**

- |                                 |                                 |
|---------------------------------|---------------------------------|
| 1. ActionScan™                  | 27. SingleFlash 90* Alt./Sync.  |
| 2. SignalAlert™ Alt.            | 28. SingleFlash 90* Sim.        |
| 3. SignalAlert™ Alt./ASync      | 29. SingleFlash 90* Alt./Sim.   |
| 4. SignalAlert™ Sim.            | 30. SingleFlash 120* Alt.       |
| 5. SignalAlert™ Alt./Sim.       | 31. SingleFlash 120* Alt./Sync. |
| 6. CometFlash® Alt.             | 32. SingleFlash 120* Sim.       |
| 7. CometFlash® Alt./ASync       | 33. SingleFlash 120* Alt./Sim.  |
| 8. CometFlash® Sim.             | 34. SingleFlash 300 Alt.        |
| 9. CometFlash® Alt./Sim.        | 35. SingleFlash 300 Alt./Sync.  |
| 10. DoubleFlash 75 Alt.         | 36. SingleFlash 300 Sim.        |
| 11. DoubleFlash 75 Alt./ASync   | 37. SingleFlash 300 Alt./Sim.   |
| 12. DoubleFlash 75 Sim.         | 38. MicroBurst™ Alt.            |
| 13. DoubleFlash 75 Alt./Sim.    | 39. MicroBurst™ Alt./ASync.     |
| 14. SingleFlash 75* Alt.        | 40. MicroBurst™ Sim.            |
| 15. SingleFlash 75* Alt./ASync  | 41. MicroBurst™ Alt./Sim.       |
| 16. SingleFlash 75* Sim.        | 42. ActionFlash™ Alt.           |
| 17. SingleFlash 75* Alt./Sim.   | 43. ActionFlash™ Alt./ASync.    |
| 18. LongBurst™ Alt.             | 44. ActionFlash™ Sim.           |
| 19. LongBurst™ Alt./ASync.      | 45. PingPong Alt.               |
| 20. LongBurst™ Sim.             | 46. PingPong Alt./ASync.        |
| 21. LongBurst™ Alt./Sim.        | 47. FlimFlam Alt.               |
| 22. SingleFlash 60* Alt.        | 48. FlimFlam Alt./ASync.        |
| 23. SingleFlash 60* Alt./ASync. | 49. ModuFlash™ Alt.             |
| 24. SingleFlash 60* Sim.        | 50. ModuFlash™ Alt./ASync.      |
| 25. SingleFlash 60* Alt./Sim.   | 51. ModuFlash™ Sim.             |
| 26. SingleFlash 90* Alt.        | 52. ZigZag.                     |

Alt. = Alternating Sim. = Simultaneous Alt./Sim. = Alternating/Simultaneous  
 Alt./ASync. = Alternating/ASynchronous \* = California Title IIX Compliant

**MR11 / Removal & Installation / Alley Light**

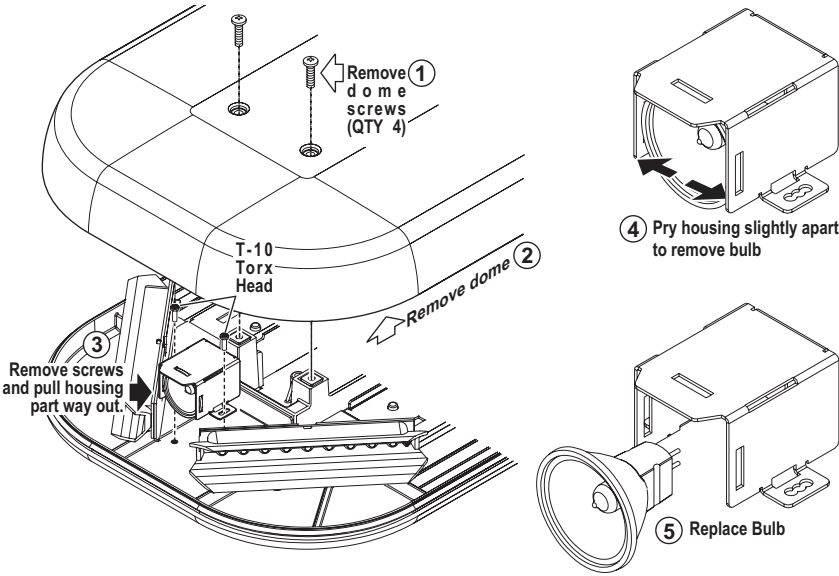

**CAUTION!** Do not handle the bulb with bare hands. Use gloves to prevent possible injury.  
**CAUTION!** Replacing any halogen bulb requires the use of safety glasses to prevent injury.

**MR-11 Halogen / Angle Adjustment**

The MR11 mounting brackets angle is adjustable  
 An alley light is shown here.

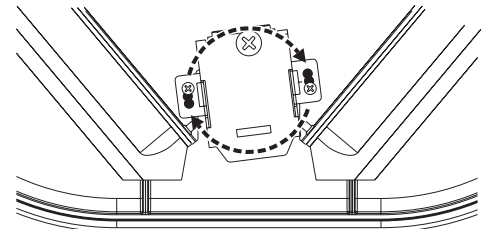

MR11's can be adjusted up to 7.5° to either side.

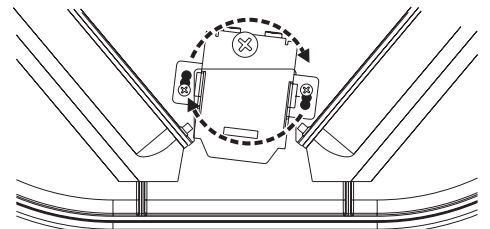

**BRAKE-TAIL**

- WHITE Tail (+)12V..... Fuse @ 1 Amp
- GREEN PS Brake (+)12V..... Fuse @ 1 Amp
- RED DS Brake (+)12V..... Fuse @ 1 Amp
- BLACK Ground (-)..... Neg. (-) Battery

**OPTIONS**

- GREEN Not Used
- RED ScanLock™ (+)12V..... Fuse @ 1 Amp
- BLACK Pattern Override (+)12V Fuse @ 1 Amp

**HALOGEN**

- WHITE Steady T.D./Worklt. (+)12V ... Fuse @ 7.5 Amps
- GREEN Pass. Alley (+)12V..... Fuse @ 3 Amps
- RED Driver Alley (+)12V..... Fuse @ 3 Amps
- BLACK Take-Down Ground (-)..... Neg. (-) Battery
- ORANGE Alley Ground (-)..... Neg. (-) Battery
- BLUE Flashing Takedown (+)12V..... Fuse @ 7.5 Amps

**LED's**

- RED Front LED's (+)12V..... Fuse @ 10 Amps
- BLACK Front LED's Ground (-)..... Neg. (-) Battery
- RED/WHT Rear LED's (+)12V..... Fuse @ 10 Amps
- BLK/WHT Rear LED's Ground (-)..... Neg. (-) Battery