



Garden Hose Reel Cart

OWNER'S MANUAL



WARNING:

Read carefully and understand all **ASSEMBLY AND OPERATION INSTRUCTIONS** before operating. Failure to follow the safety rules and other basic safety precautions may result in serious personal injury.

Item# 163152

Thank you very much for choosing a Wel-Bilt™ product! For future reference, please complete the owners record below:

Model: _____ Purchase Date: _____

Save the receipt, warranty and these instructions. It is important that you read the entire manual to become familiar with this product before you begin using it.

This machine is designed for certain applications only. The distributor cannot be responsible for issues arising from modification. We strongly recommend this machine not be modified and/or used for any application other than that for which it was designed. If you have any questions relative to a particular application, DO NOT use the machine until you have first contacted the distributor to determine if it can or should be performed on the product.

For technical questions please call **1-800-222-5381**.

INTENDED USE

Heavy-duty hose reel cart has a strong tubular steel frame, foam-padded handle and tires for easy maneuverability. Holds up to 300 feet of garden hose for easy reach to about anywhere in your yard.

TECHNICAL SPECIFICATIONS

Item	Description
Capacity	300 feet of 5/8in. hose (not included)
Tires	10 in. pneumatic
Construction	Tubular powder-coat steel frame

GENERAL SAFETY RULES



WARNING: Read and understand all instructions. Failure to follow all instructions listed below may result in serious injury.



CAUTION: Do not allow persons to operate or assemble this Hose Reel Cart until they have read this manual and have developed a thorough understanding of how the Hose Reel Cart works.



WARNING: The warnings, cautions, and instructions discussed in this instruction manual cannot cover all possible conditions or situations that could occur. It must be understood by the operator that common sense and caution are factors which cannot be built into this product, but must be supplied by the operator.

SAVE THESE INSTRUCTIONS

WORK AREA

- **Keep work area clean**, free of clutter and well lit. Cluttered and dark work areas can cause accidents.
- **Keep children and bystanders** away while operating a Hose Reel Cart and Hose. Distractions can cause you to lose control, so visitors should remain at a safe distance from the work area.
- **Be aware of all power lines, electrical circuits**, water pipes and other mechanical hazards in your work area, particularly those hazards below the work surface hidden from the operators view that may be unintentionally contacted and may cause personal harm or property damage.
- **Be alert of your surroundings**. Using a Hose Reel Cart and Hose in confined work areas may put you dangerously close to cutting tools and rotating parts.
- **PERSONAL SAFETY**
- **Stay alert**, watch what you are doing and use common sense when using a Hose Reel Cart and Hose. Do not use a Hose Reel Cart and Hose while you are tired or under the influence of drugs, alcohol or medication. A moment of inattention while operating a hose reel may result in serious personal injury.
- **Dress properly**. Do not wear loose clothing, dangling objects, or jewelry. Keep your hair, clothing and gloves away from moving parts. Loose clothes, jewelry or long hair can be caught in moving parts.

HOSE REEL CART USE AND CARE

- **Do not modify the Hose Reel Cart in any way**. Unauthorized modification may impair the function and/or safety and could affect the life of the equipment. There are specific applications for which the Hose Reel Cart was designed.
- **Always check of damaged or worn out parts before using the Hose Reel Cart**. Broken parts will affect operation. Replace or repair damaged or worn parts immediately.
- **Use the Hose Reel Cart on flat and level surfaces**. Pulling or pushing a load on a slanted or uneven surface can result in loss of control.
- **The Hose Reel Cart is not a toy**. Never allow children to play or ride on the Hose Reel Cart.
- **Store idle** Hose Reel Cart. When Hose Reel Cart is not in use, store it in a secure place out of the reach of children. Inspect it for good working condition prior to storage and before re-use.

ASSEMBLY (See Parts List and Hardware List in back of this manual)

ASSEMBLY INSTRUCTIONS

1. (SEE FIGURE 1) Place Frame (A₁) into Frame (A₂) insert Bolt (6) and place flat washer (12) onto Bolt. Fasten frame using lock nut(11).

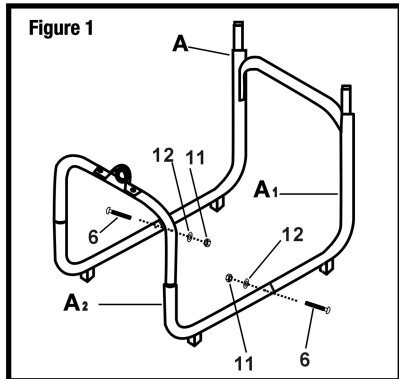

2. (SEE FIGURE 2) Remove and retain lock nut (9) and flat washer (10) from axle (B). Stand frame assembly (A) upright. Slide each axle (B) through both ends of frame (A).

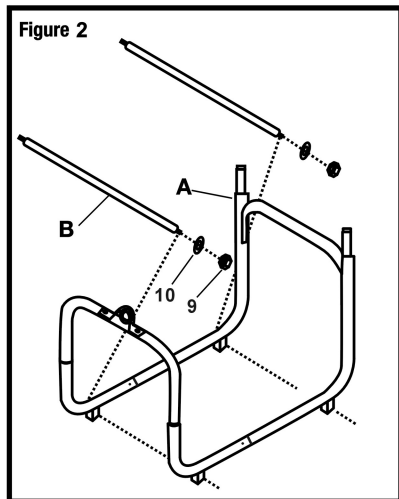

3. (SEE FIGURE 3) Slide wheels (C) onto ends of each axles (B), with the wheel valve stems facing outward. Fasten each wheel to axle using flat washers(10) and lock nuts (9). Do not over tighten.

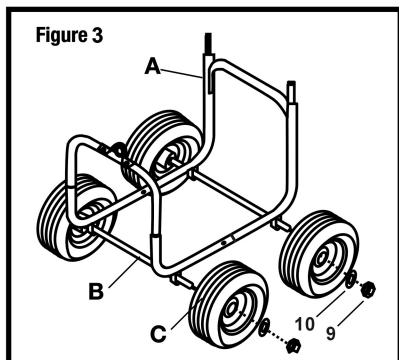

4. (SEE FIGURE 4) Insert the end of crank handle (E) through crank hub of frame (A).

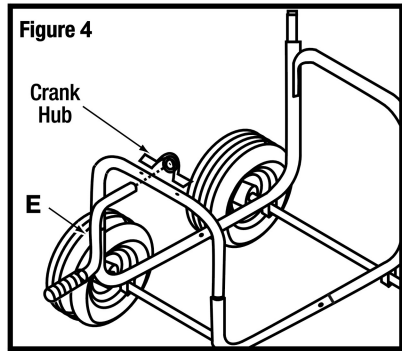

5. (SEE FIGURE 5) Attach the first hose reel (D) to the roller (I), on the end with the crank handle stem, using 6 bolts (5). On the opposite end of the roller (I), insert the watercoupling (J) into the center hole of the reel and roller. Place the U bracket (13) over the tubing of the water coupling (J). Use 7 bolts (5) to attach the U bracket, water coupling and reel to the roller.

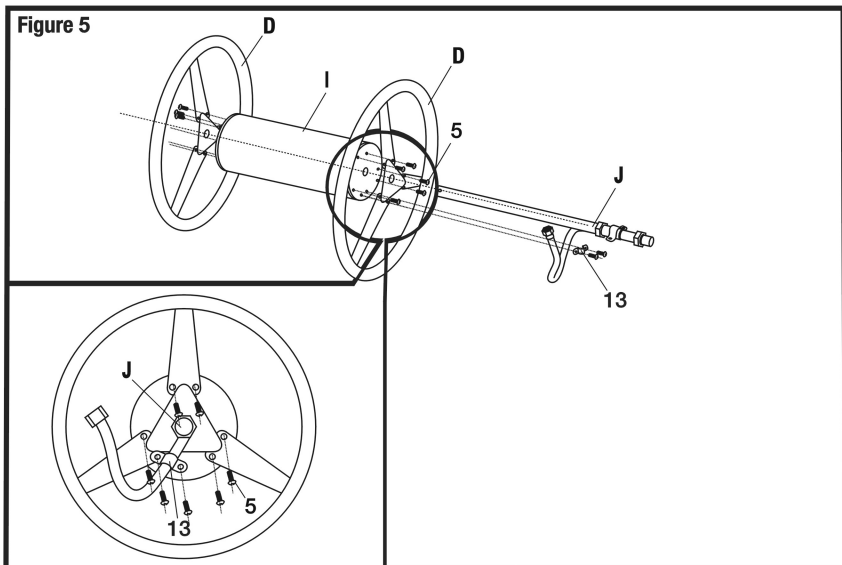

6. (SEE FIGURE 6) Place hose reel (D) into frame assembly (A). Insert end of crank stem from hose reel (D) onto crank handle (E).

Align crank handle (E) mounting holes with crank stem mounting holes.

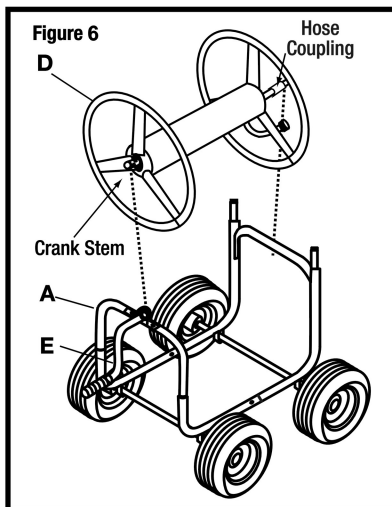

7. (SEE FIGURE 7) Insert bolt (3) through inside hole of crank stem and crank handle hole, Place flat washer (10) onto bolt (3) fasten with lock nut (11).

Insert bolt (3) through outside hole of crank stem and crank handle hole and fasten with lock nut (11).

Tighten all fasteners securely.

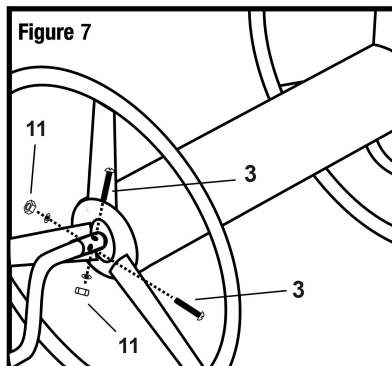

8. (SEE FIGURE 8) Attach hose coupling end of hose reel (D) to frame (A), using U-Bracket. Fasten U-bracket to frame with carriage bolts (I) and lock nuts (Q). Tighten securely.

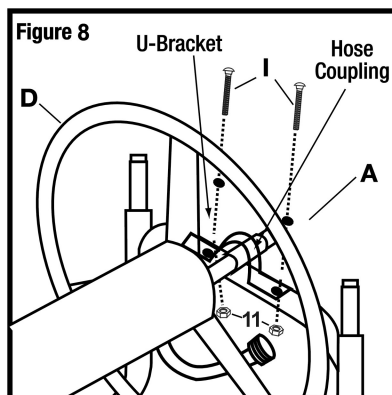

9. (SEE FIGURE 9) Place handle (F) onto vertical posts of frame (A). Align mounting holes. Slide bolt (2) through mounting holes and place flat washer (12) onto bolt (2). Fasten handle (F) using lock nut (11).

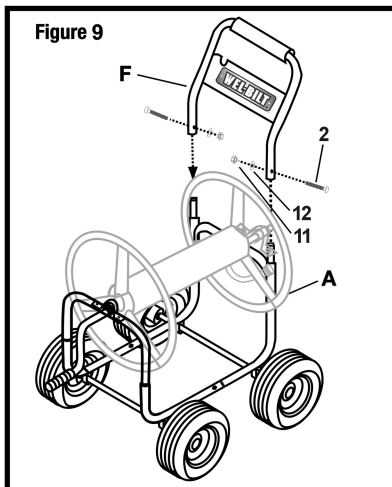

10. (SEE FIGURE 10) Attach basket (H) to handle (F). Place flat washer (8) onto bolt (4) and slide both bolts through mounting holes of handle (F). Place basket (H) mounting tabs onto bolts (4) then place flat washer (8) onto both bolts. Fasten basket using hex nuts (7).

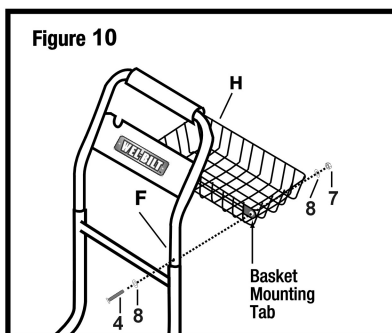

11. (SEE FIGURE 11) Place rubber washer (14) into female end of water coupling on hose reel (D) drum. Attach one end of leader hose (G) to water coupling on hose reel (D) drum. Attach the other end of leader hose (G) to the water supply spigot. Attach garden hose to threaded garden hose connector and wind garden hose around hose reel (D).
- NOTE:** The hose reel will hold up to 300' of 5/8" garden hose.
(Garden Hose Not Included)

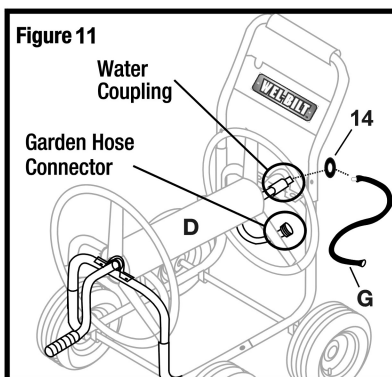

MAINTENANCE

Maintain your Hose Reel Cart. It is recommended that the general condition of the Hose Reel Cart be examined before it is used. Keep your Hose Reel Cart in good repair by adopting a program of conscientious repair and maintenance. Have necessary repairs made by qualified service personnel.

DIAGRAM & PARTS LIST

PARTS LIST		
PART #	DESCRIPTION	QUANTITY
A ₁ A ₂	Frame	2
B	Axles	2
C	Wheels	4
D	Hose Reel	2
E	Crank Handle	1
F	Handle	1
G	Leader Hose	1
H	Accessories Basket	1
I	Roller	1
J	Water Coupling	1

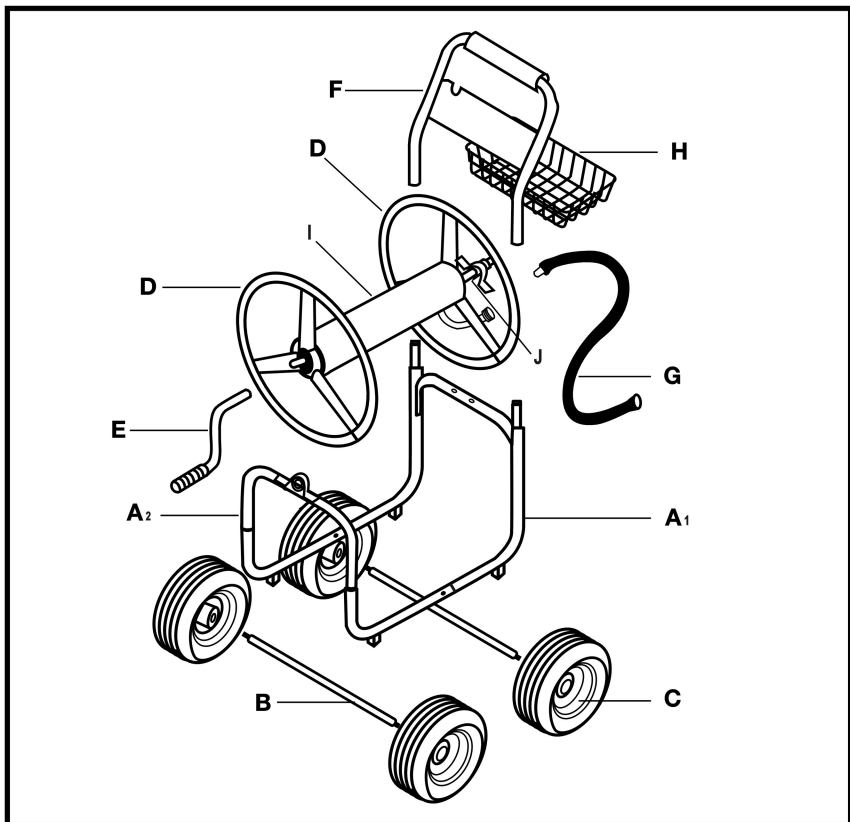

HARDWARE LIST

PART #	DESCRIPTION	QUANTITY
1	Carriage Bolt, 6 x 35mm	2
2	Carriage Bolt, 6 x 39mm	2
3	Bolt, 6 x 26mm	2
4	Bolt, 8 x 45mm	2
5	Bolt, 5 x 15mm	13
6	Bolt, 6 x 40mm	2
7	Hex Nut, 8mm	2
8	Flat Washer, 8mm	2
9	Lock Nut, 12mm	4
10	Flat Washer, 12mm	4
11	Lock Nut, 6mm	8
12	Flat Washer, 6mm	8
13	U Bracket	1
14	Rubber Washer (Includes 1-Spare Rubber Washer)	2

Carefully remove the contents from the package. If any parts are missing do not attempt to use the product until they have been obtained and correctly installed.

The proportion of the following bolt, nut and flat washer to material object is 1:1.

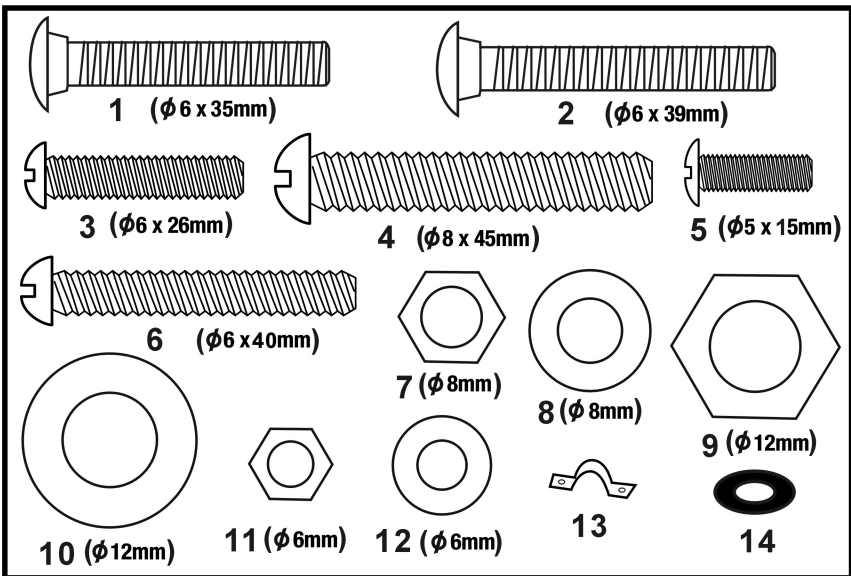

For replacement parts and technical questions, please call **1-800-222-5381**.

WARRANTY

One-Year Limited Warranty



Distributed by
Northern Tool + Equipment Co., Inc.
Burnsville, Minnesota 55306-6936
Made in China